

NOTES:

If this document is printed it becomes uncontrolled.
Check with the web for latest revision.

- THIS BOXMOUNT RECEPTACLE MATES WITH A MTC PLUG CONTAINING SOCKET INSERTS. REFER TO APPLICABLE RAYCHEM SPECIFICATION CONTROL DRAWING FOR DETAILS.
- FOR KEYING INFORMATION. SEE RAYCHEM DRAWING D-659-0080.
- THESE ITEMS ARE SUPPLIED UNASSEMBLED.
- DIMENSION SHOWN IS WITH MATED PLUG CONNECTOR:
 - WITH CABLE CLAMP
 - WITHOUT CABLE CLAMP AND WITHOUT EARS
- THE BOXMOUNT RECEPTACLE IS REAR PANEL MOUNTED BY REMOVING AS MANY PANEL WASHERS AS REQUIRED TO ACCOMMODATE THE THICKNESS OF THE PANEL BEING USED. SEE SHEET 3, TABLE 3.
- .025 WIRE WRAPPABLE POST DESIGNED TO MIL-STD-1130.
- PART NUMBER VARIABLE: (SEE SHEET 2 FOR ADDITIONAL INFORMATION)

MTC50-BXX-PXX-XXX-XXX

 - PRE-PRODUCTION LEVEL (SEE TABLE 4) (BLANK WHEN NOT APPLICABLE)
 - MODIFICATION NUMBER. REFER TO APPLICABLE MOD DESCRIPTION SHEET. ("BLANK WHEN NOT APPLICABLE")
 - 1 = LONG TAIL
 - 2 = SHORT TAIL
 - 3 = 90° BEND "B" DIRECTION
 - 2=NICKEL PLATE
 - 3=CADMIUM OVER NICKEL PLATE
 - 1=1 INCH
 - 2=2 INCH
 - F = FLANGED WITH STANDARD PANEL GASKET
 - J = FLANGELESS
 - S = FLANGED/SHIELDED WITH EME PANEL GASKET
 - Y = SPECIALS: REFER TO INDIVIDUAL SPECIFICATION CONTROL DRAWINGS FOR DESCRIPTIONS
- SEE SHEET 3, TABLE 2. FOR WEIGHTS. WEIGHTS SHOWN ARE WITHOUT DUST CAP AND WITHOUT POST PROTECTOR.
- CAP SCREW INSTALLATION TORQUE 14-16 INCH POUNDS.
- DUST CAP SUPPLIED WITH EACH RECEPTACLE HOUSING.
- ONE INCH TERMINATION POST NUMBERING IS SHOWN ON SHEET ONE FOR .025 POSTS. FOR TWO INCH TERMINATION POST NUMBERING AND .020 x .025 TERM POST MARKING SEE SHEET 2, DETAIL "Y".
- INNER GASKET IS SUPPLIED ONLY WHEN THE APPROPRIATE INNER GASKET MODIFICATION IS APPLIED TO THE END OF THE PART NUMBER. REFER TO MODIFICATION DESCRIPTION SHEETS FOR APPROPRIATE MOD. NUMBER. CONSULT FACTORY WHEN UNCERTAINTIES EXIST.
- CONNECTORS WITH BENT TAILS FOR PCB APPLICATIONS HAVE .020 x .025 POSTS.
- WHEN MOUNTING FLANGELESS CONNECTORS ADJACENT TO ONE ANOTHER AND USING THE .400 MINIMUM CENTERLINE LOCATION, THERE WILL BE NO WEB BETWEEN PANEL CUT-OUTS. SEE SHEET 3 FOR DETAILS.

VIEW X-X

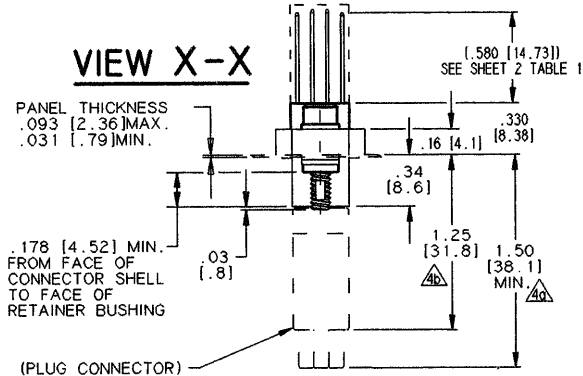

REVISIONS		DATE	APPROVED
LTR	DESCRIPTION		
D	REVISED PER ECN T-21623A	8/13/97	M. HIGGY

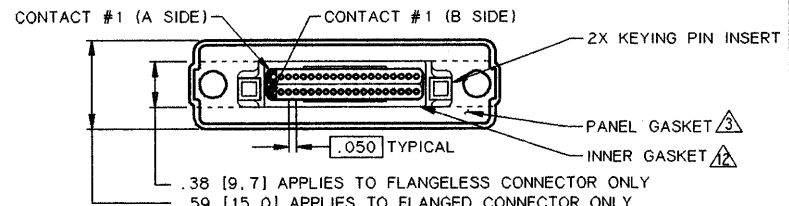
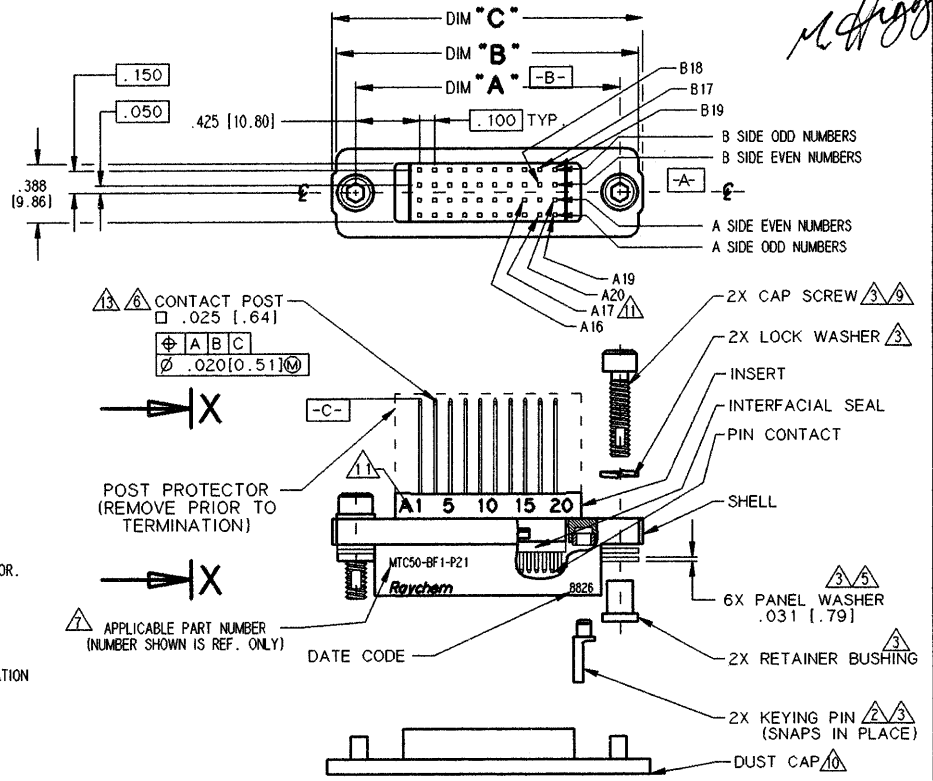

SPECIFICATION CONTROL DRAWING © Raychem Corporation 1988

UNLESS OTHERWISE SPECIFIED DIMENSIONS ARE IN INCHES. METRIC DIMENSIONS ARE IN BRACKETS.	DRAWN	LUTTICKEN	88SEPT20	Raychem RAYCHEM CORPORATION 300 CONSTITUTION DRIVE MENLO PARK, CALIFORNIA 94025	
	CHECKED				
	APPROVED	J. BLAIR	88 SEPT 30		
	APPROVED	J. CAMERON	88 SEPT 30		
DECIMALS	.XX ± .005 [± .13mm]			TITLE	CONNECTOR RECEPTACLE, FLANGED, BOXMOUNT, .025 SQ. TERMINATION POST
ANGLES	.X ±			CAD NAME	T21623A.DWG
WEIGHT: MAXIMUM (SEE SHEET 3, TABLE 1)				SIZE	C 06090
				CODE IDENT. NO.	MTC50-BXX-PXX-XXX-XXX
				DWG. NO.	
				REV	D
				DO NOT SCALE THIS DRAWING	
				SHEET 1 OF 3	

PART NO. MTC50-BXX-PXX-XXX-XXX SHEET 1

TABLE 1 BASIC DESIGNS AVAILABLE

<p>TERMINATION POSTS .580 MINIMUM LENGTH FLANGELESS MTC50-BJX-PX1</p>	<p>TERMINATION POSTS .240 MINIMUM LENGTH FLANGELESS MTC50-BJX-PX2</p>	<p>TERMINATION POSTS BENT 90° IN "B" DIRECTION FLANGELESS MTC50-BJX-PX3</p>	<p>TERMINATION POSTS .580 MINIMUM LENGTH FLANGED MTC50-BF/SX-PX1</p>	<p>TERMINATION POSTS .240 MINIMUM LENGTH FLANGED MTC50-BF/SX-PX2</p>
--	--	--	---	---

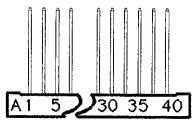
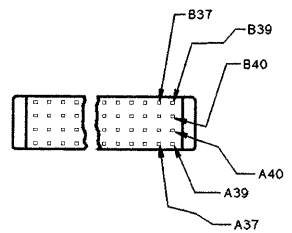
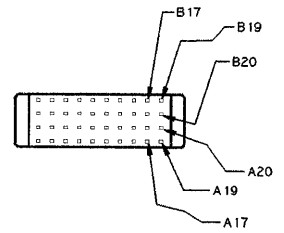
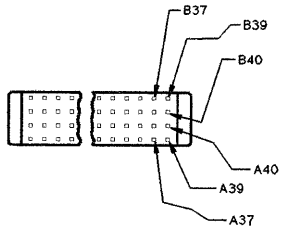
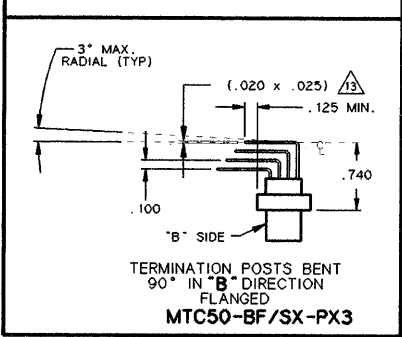

TWO INCH TERMINATION
POST NUMBERING
.025 SQ. POST

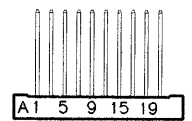

ONE INCH TERMINATION
POST NUMBERING
.020 X .025 SQ. POST

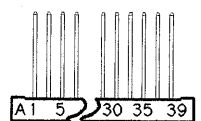

TWO INCH TERMINATION
POST NUMBERING
.020 X .025 SQ. POST

DETAIL Y



If this document is printed it becomes uncontrolled.
Check with the web for latest revision.

SPECIFICATIONS:

MATERIALS:

- A. SHELL ALUMINUM ALLOY PER QQ-A-591
- B. CAP SCREW STAINLESS STEEL PER QQ-S-763, 300 SERIES
- C. RETAINER BUSHING STAINLESS STEEL PER QQ-S-763, 300 SERIES
- D. PANEL WASHER STAINLESS STEEL PER QQ-S-763, 300 SERIES
- E. LOCK WASHER STAINLESS STEEL PER QQ-S-763, 300 SERIES
- F. PIN CONTACT COPPER ALLOY 172 PER QQ-C-533
- G. STANDARD PANEL GASKET SILICONE ELASTOMER PER MIL-R-25988
EME PANEL GASKET CONDUCTIVE FLUOROSILICONE
- H. PIN INSERT HIGH GRADE POLYARYLENE THERMOPLASTIC
- J. KEYING PIN INSERT HIGH GRADE POLYARYLENE THERMOPLASTIC
- K. KEYING PIN HIGH GRADE POLYARYLENE THERMOPLASTIC
- L. INTERFACIAL SEAL FLUOROSILICONE ELASTOMER PER MIL-R-25988

FINISH:

APPLIES TO NICKEL PLATED CONNECTORS (STANDARD PLATING)	APPLIES TO CADMIUM PLATED CONNECTORS
--	--------------------------------------

- | | | |
|---------------------|--|--|
| A. SHELL | NICKEL PLATED PER MIL-C-26074 CLASS 3, GRADE B | CADMIUM PLATED PER QQ-P-416 OVER NICKEL UNDERPLATE |
| B. CAP SCREW | PASSIVATED PER QQ-P-35 | CADMIUM PLATED PER QQ-P-416 |
| C. RETAINER BUSHING | PASSIVATED PER QQ-P-35 | CADMIUM PLATED PER QQ-P-416 |
| D. PANEL WASHER | PASSIVATED PER QQ-P-35 | CADMIUM PLATED PER QQ-P-416 |
| E. LOCK WASHER | PASSIVATED PER QQ-P-35 | CADMIUM PLATED PER QQ-P-416 |
| F. PIN CONTACT | GOLD PLATED PER MIL-G-45204 TYPE 1, GRADE C, CLASS 1 | |

DESIGN AND CONSTRUCTION:

THE CONNECTORS SPECIFIED HEREIN ARE PANEL MOUNTED RECEPTACLES WITH FIXED (NON REMOVABLE) PIN INSERTS AND CONTACTS. THE CONNECTOR IS WITHOUT PROVISIONS FOR CABLE CLAMPS OR TERMINATION SEALS.

PERFORMANCE:

THE APPLICABLE RAYCHEM SPECIFICATION FOR THIS PART IS C6111. THIS PART IS NOT QUALIFIED TO C6111.

HUMIDITY
ALTITUDE IMMERSION
ALTITUDE-LOW TEMPERATURE
FLUID IMMERSION

THE CONNECTOR TERMINATION END MUST BE SUITABLY PROTECTED FOR TESTING OR APPLICATION IN ANY OF THESE ENVIRONMENTS.

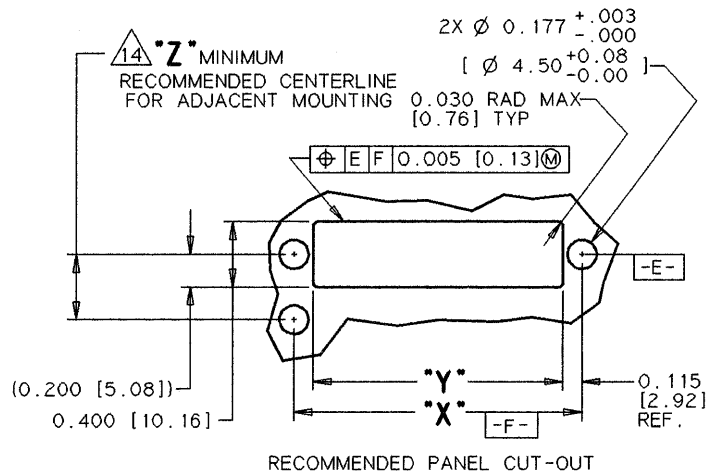

RECOMMENDED PANEL CUT-OUT

TABLE 2

CONNECTOR SIZE	"A"	"B"	"C"	"X"	"Y"	"Z" (MIN)	WEIGHT lbs. (gr.) MAX
1 INCH	FLANGELESS	1.750 [44.45]	2.00 [50.8]	X	1.750 [44.45]	1.520 [38.61]	0.400 [10.16]
	FLANGED	1.750 [44.45]	X	2.06 [52.3]	1.750 [44.45]	1.520 [38.61]	0.600 [15.24]
2 INCH	FLANGELESS	2.750 [69.85]	3.00 [76.2]	X	2.750 [69.85]	2.520 [64.00]	0.400 [10.16]
	FLANGED	2.750 [69.85]	X	3.06 [77.7]	2.750 [69.85]	2.520 [64.00]	0.600 [15.24]

TABLE 3

PANEL THICKNESS	NUMBER OF PANEL WASHERS FOR EACH FASTENER
.031/.036 [.8]/[.9]	2
.062/.067 [1.5]/[1.7]	1
.093/.097 [2.3]/[2.4]	0

TABLE 4 PRE-PRODUCTION TRACKING

PART NUMBER	LEVEL	DESCRIPTION
MTC50-BJI-P33-PP1	PP1	MACHINED SHELL

If this document is printed it becomes uncontrolled. Check with the web for latest revision.