



© - TE Connectivity. All Rights Reserved.		
PART NO	PKG TYPE	QTY
8-36919-3	BOX	25
8-36919-5	BAG	5
36919	BOX	50

REVISIONS				
P	LTR	DESCRIPTION	DATE	APVD
K3		REVISED PER ECN-22-150900	28APR2022	RK CSD

AMP WIRE RANGE	 Listed FILE E13288
1/0 AWG STRANDED	1/0 AWG STRANDED
 LR7189 Certified	
1/0 AWG STRANDED	

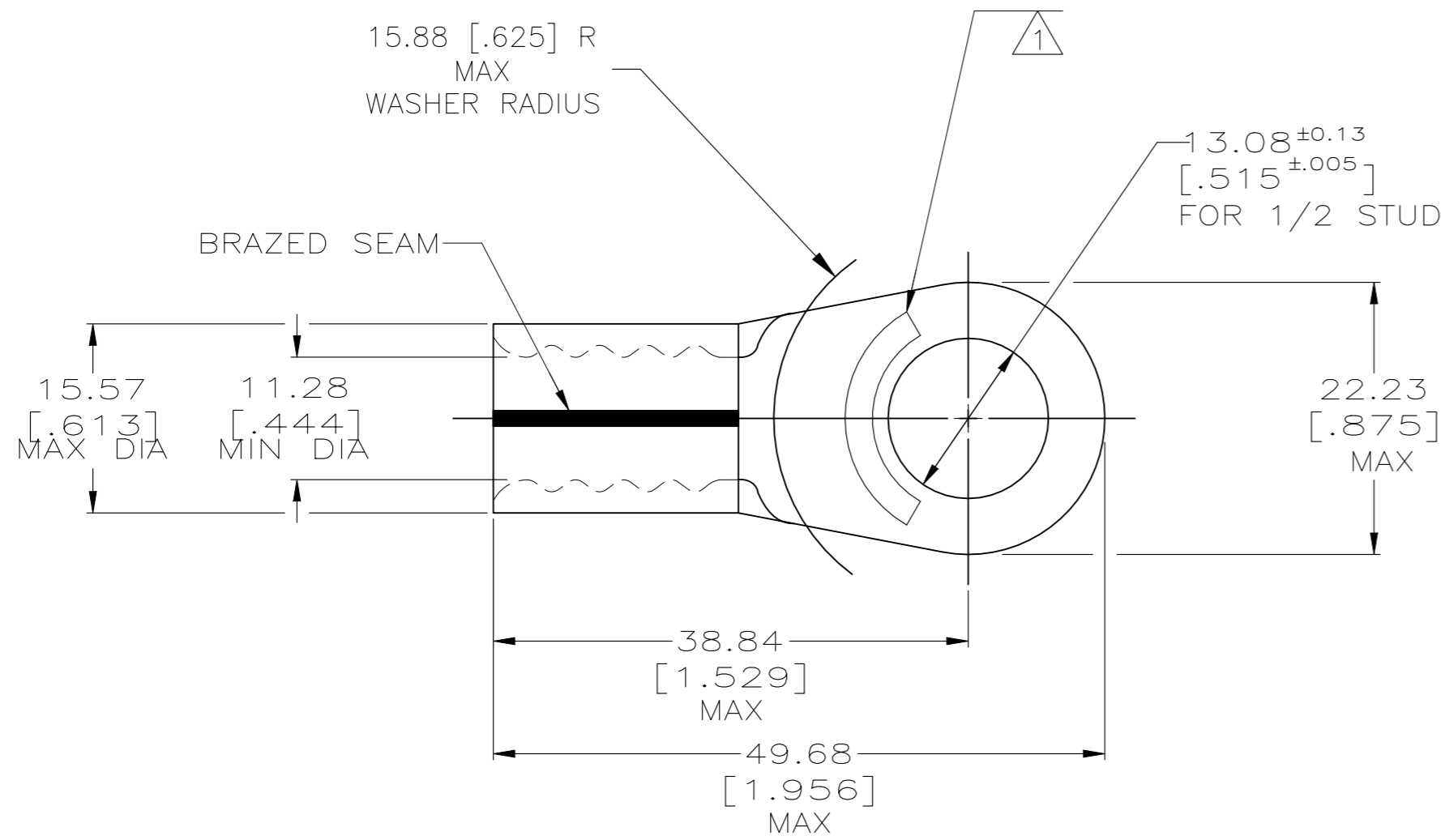

- 1 STAMP AMP 1/0W* APPROX AS SHOWN
- 2 MATERIAL THK IS 1.78±0.08 [.070±.003]
- 3 COPPER PER ASTM B-152, ANNEALED
- 4 TIN PLATE 0.00254 [.000100] MIN THK PER ASTM B-545

36919
PART NO.

AMP INCORPORATED CUSTOMER SERVICE SYSTEMS		MAX RECOMMENDED OPERATING TEMPERATURE: 170°C MAX
FOR ADDITIONAL PRODUCT INFORMATION OR COPIES OF DRAWINGS AND TECHNICAL DOCUMENTS	PRODUCT INFORMATION CENTER 1-800-522-6752	VOLTAGE RATING: N/A
FOR APPLICATION TOOLING INFORMATION	TOOLING ASSISTANCE CENTER 1-800-722-1111	CIRCULAR MIL AREA: 42.4-60.6mm ² [83,700-119,500] STRANDED
FOR ORDER ENTRY	1-800-526-5142	THIS DRAWING IS A CONTROLLED DOCUMENT FOR AMP INCORPORATED. IT IS SUBJECT TO CHANGE AND THE CONTROLLING ENGINEERING ORGANIZATION SHOULD BE CONTACTED FOR THE LATEST REVISION.

THIS DRAWING IS A CONTROLLED DOCUMENT.		DWN DK_SCHRUM 7/21/91	 TE Connectivity	
DIMENSIONS: MM [INCHES]		CHK RD_HEIM 8/15/91		
TOLERANCES UNLESS OTHERWISE SPECIFIED:		APVD AJ KAUFMAN 8/15/91	NAME	
0 PLC ± -		PRODUCT SPEC	TERMINAL, RING TONGUE, SOLISTRAND	
1 PLC ± -		APPLICATION SPEC	SIZE A2	CAGE CODE 00779
2 PLC ± 0.20[.008]		WEIGHT -	DRAWING NO C=36919	RESTRICTED TO -
3 PLC ± -		CUSTOMER DRAWING	SCALE 2:1	SHEET 1 OF 2
4 PLC ± -			REV K3	
ANGLES ± -				

© - TE Connectivity. All Rights Reserved.

PART NO	PKG TYPE	QTY
36919-1	BOX	50

REVISIONS				
P	LTR	DESCRIPTION	DATE	APVD
-	-	SEE SHEET 1	-	-

AMP
WIRE RANGE

1/0 AWG
SOLID OR STRANDED

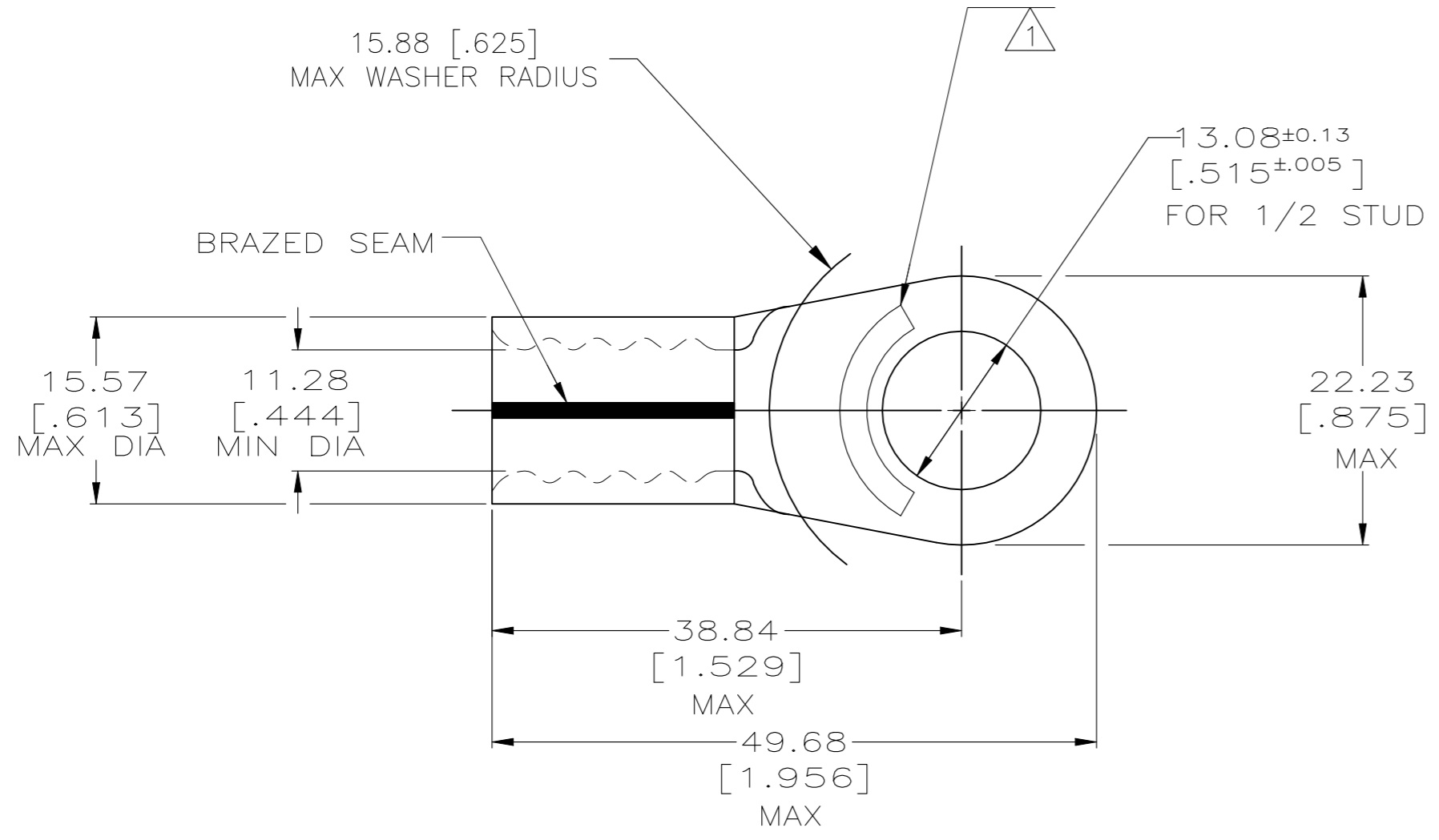

- 1 STAMP AMP 1/0W* APPROX AS SHOWN
- 2 MATERIAL THK IS 1.78±0.08 [.070±.003]
- 3 COPPER PER ASTM B-152, ANNEALED
- 4 NICKEL PLATE 0.00762 [.000300] MIN THK PER QQ-N-290

36919-1
PART NO.

AMP INCORPORATED CUSTOMER SERVICE SYSTEMS		MAX RECOMMENDED OPERATING TEMPERATURE: 343°C MAX
FOR ADDITIONAL PRODUCT INFORMATION OR COPIES OF DRAWINGS AND TECHNICAL DOCUMENTS	PRODUCT INFORMATION CENTER 1-800-522-6752	VOLTAGE RATING: N/A
FOR APPLICATION TOOLING INFORMATION	TOOLING ASSISTANCE CENTER 1-800-722-1111	CIRCULAR MIL AREA: 42.4-60.6mm² [83,700-119,500] SOLID OR STRANDED
FOR ORDER ENTRY	1-800-526-5142	THIS DRAWING IS A CONTROLLED DOCUMENT FOR AMP INCORPORATED. IT IS SUBJECT TO CHANGE AND THE CONTROLLING ENGINEERING ORGANIZATION SHOULD BE CONTACTED FOR THE LATEST REVISION.

THIS DRAWING IS A CONTROLLED DOCUMENT.		DWN DK_SCHRUM 7/21/91	STE TE Connectivity	
DIMENSIONS: MM [INCHES]		CHK RD_HEIM 8/15/91		
TOLERANCES UNLESS OTHERWISE SPECIFIED:		APVD AJ KAUFMAN 8/15/91	NAME	
0 PLC ± -		PRODUCT SPEC	TERMINAL, RING TONGUE, SOLISTRAND	
1 PLC ± -		APPLICATION SPEC	SIZE	CAGE CODE
2 PLC ± 0.20[.008]		WEIGHT	A2	00779
3 PLC ± -		FINISH	DRAWING NO	
4 PLC ± -			C=36919	
ANGLES ± -			RESTRICTED TO	
MATERIAL - 3			SCALE	SHEET
			2:1	2 OF 2
				REV K3