

## ISL54409EVAL1Z, ISL54410EVAL1Z

### Evaluation Boards

AN1501  
Rev 0.00  
October 8, 2009

## Description

The ISL54409EVAL1Z and ISL54410EVAL1Z evaluation board are designed to provide a quick and easy method for evaluating the ISL54409 and ISL54410 Audio/USB wired-OR IC switch.

To use the evaluation board properly requires a thorough knowledge on the operation of the ISL54409 and ISL54410 IC. Refer to the ISL54409, ISL54410 data sheet for the features and functions of the device. Studying the device's logic truth table along with the Applications Block Diagram is a quick way to understanding the operation of the IC.

A picture of the main evaluation board is shown in Figure 1. The ISL54409, ISL54410  $\mu$ TQFN IC is soldered onto the evaluation board. It is designated as U1.

The ISL54409 and ISL54410 is a dual SPST audio switch with low OFF capacitance on the output terminals. This allows USB 2.0 HS signals to be connected to the output terminals with minimal degradation of the USB signal in a wired-OR configuration for 2:1 multiplexing of audio and USB2.0 signals to a common connector.

For example, a headphone can be plugged into the headphone jack (J11) and an audio signal can be applied to the BNC connectors J9 and J10 when the switch is placed into the audio mode. The switch can be turned off and placed into the USB mode, allowing a USB 2.0 device to be plugged into J4 and a USB 2.0 Host to be plugged into J5. The USB D+ and D- lines are connected to the switch COM+ and COM- terminals which allows a mutually exclusive common connector for multiplexing audio and USB signals.

The ISL54409 features a low power shut down mode while the ISL54410 features integrated Audio Click and Pop Elimination. This application note will guide the user through the process of configuring and using the evaluation board to evaluate the ISL54409 or ISL54410 device.

## Key Features

- Standard USB Connectors
- BNC Input Jacks and Headphone Speaker Jack
- On-board or External Logic Control
- Convenient Test Points and Connections for Test Equipment

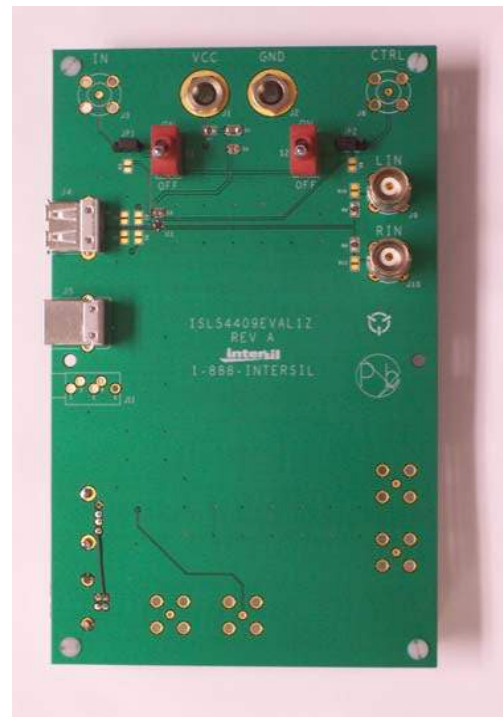

FIGURE 1. ISL54409EVAL1Z EVALUATION BOARD (TOP VIEW)

## Board Architecture/ Layout

### Basic Layout of Evaluation Board

The basic layout of the main board is as follows: Refer to Figure 1.

1. VCC and GND connections are at the top of the board (J1 and J2). The board operates on a +2.7V to +5.0V power supply.
2. Logic control connections are at the top of the board (J3 and J8 for external control. S1 and S2 for on-board control).
3. Audio inputs are at the upper right side of the board (J9 and J10). Audio outputs are at the standard headphone connector (J11).
4. USB connection to an upstream host controller is made at connector J5. USB connection to a downstream USB device is made at connector J4.
5. Located below S1 of the board is the ISL54409 or ISL54410 IC (U1).

## Power Supply

The DC power supply connected at banana jacks J1 (VCC) and J2 (GND) provides power to the evaluation board. The IC requires a +2.7V to +5.0V DC power supply for proper operation. The power supply should be capable of delivering 100 $\mu$ A of current.

## Logic Control

The state of the ISL54409 and ISL54410 device is determined by the voltage at the IN pin and the CTRL pin. When the JP1 three pin jumper is in the 1-2 position, access to the IN pin is through the BNC connector J3. When the jumper is in the 2-3 position, access to the IN pin is through switch S1. When the JP2 three pin jumper is in the 2-3 position, access to the CTRL pin is through the BNC connector J8. When the jumper is in the 1-2 position, access to the CTRL pin is through switch S2.

The IN and CTRL pins are 1.8V logic compatible which allows for control via a standard  $\mu$ controller.  
Logic "0" (LOW) when  $\leq 0.5V$  or floating  
Logic "1" (HIGH) when  $\geq 1.4V$

Note: The evaluation board has a 1M $\Omega$  pull-down resistor from the IN pin to ground and CTRL pin to ground. In addition, the ISL54409 and ISL54410 IC have an internal 4M $\Omega$  pull-down resistor on the IN and CTRL logic pins. If the user wishes to remove the 1M $\Omega$  resistors on the board simply depopulate R<sub>2</sub> for the CTRL pin and R<sub>3</sub> for the IN pin.

If IN is LOW and CTRL is HIGH the part will be in the Audio mode. The switches will be ON and can pass audio signals from the LIN/RIN to COM-/COM+. If IN is driven HIGH and CTRL = X (don't care) the part will be in the USB mode. The switches will be turned OFF, providing excellent signal isolation from LIN/RIN to COM-/COM+.

For the ISL54409 if IN is logic "0" and CTRL is logic "0" the part will be in the Low Power mode. In Low Power mode both switches are OFF and the part will draw less than 10nA typically.

For the ISL54410 if IN is logic "0" and CTRL is logic "0" the part will be in the Audio Click and Pop mode. In Audio Click and Pop mode both switches are OFF and the LIN/RIN pins will have a 40 $\Omega$  shunt path to ground.

## Audio Inputs

The evaluation board has two audio inputs, LIN (J9) and RIN (J10) using BNC connectors on the right side of the evaluation board. Over a signal range of -1V to +1V (0.707V<sub>RMS</sub>) these switches have an extremely low ON-resistance variation. The r<sub>ON</sub> of the switch is typically less than 3 $\Omega$ . They can pass ground referenced audio signals with very low distortion (<0.04% THD+N) when delivering 4mW into a 32 $\Omega$  headphone speaker load. A signal range above 0.707V<sub>RMS</sub> is acceptable but THD+N performance will degrade.

## Audio Outputs

The evaluation board has a standard headphone jack (J11) connected to the COM- and COM+ pins. A headphone with a 3.5mm audio jack can be plugged into the evaluation board.

\* Note that in a typical application the USB and audio connections use a common connector. This evaluation board has separate connectors for USB and audio for simplicity in evaluating the performance of USB and audio signals. However, for optimal USB 2.0 HS performance, the headphone jack can be disconnected from the COM-/COM+ path. This can be done by depopulating resistors R<sub>6</sub> and R<sub>7</sub> on the evaluation board.

## USB Connections

A type A USB receptacle (J4) and a type B USB receptacle (J5) is located on the left side of the board. The type B receptacle should be connected using a standard USB cable to the upstream USB host controller which is usually a PC computer or hub. A USB device can be plugged directly into this receptacle. When this connection is made and the IN logic control is driven HIGH, the ISL54409, ISL54410 device will go into USB mode. The switches will be turned OFF and the USB Host and USB device can communicate.

Note: Before operating in the USB mode, the headphones must be removed from the headphone speaker jack. This will prevent the audio load from interfering with USB signal transmission. The main purpose of the ISL54409, ISL54410 IC is to allow the use of a common USB and Audio Headphone Connector in Personal Media Players and other portable battery powered equipment. Either a headphone will be in the common connector to play music or a USB cable from a computer will be in the common connector to transmit digital data.

TABLE 1. EVALUATION BOARD COMPONENT DEFINITIONS

DESIGNATOR	DESCRIPTION
U1	ISL54409IRUZ or ISL54410IRUZ IC
J1	VCC Banana Jack Connection
J2	GND Banana Jack Connection
J3	IN Logic Control; BNC Connector
J4, J5	Standard USB Connectors
J8	CTRL Logic Control; BNC Connector
J9	LIN BNC Connector
J10	RIN BNC Connector
S1	IN Logic Control; Toggle Switch
S2	CTRL Logic Control; Toggle Switch

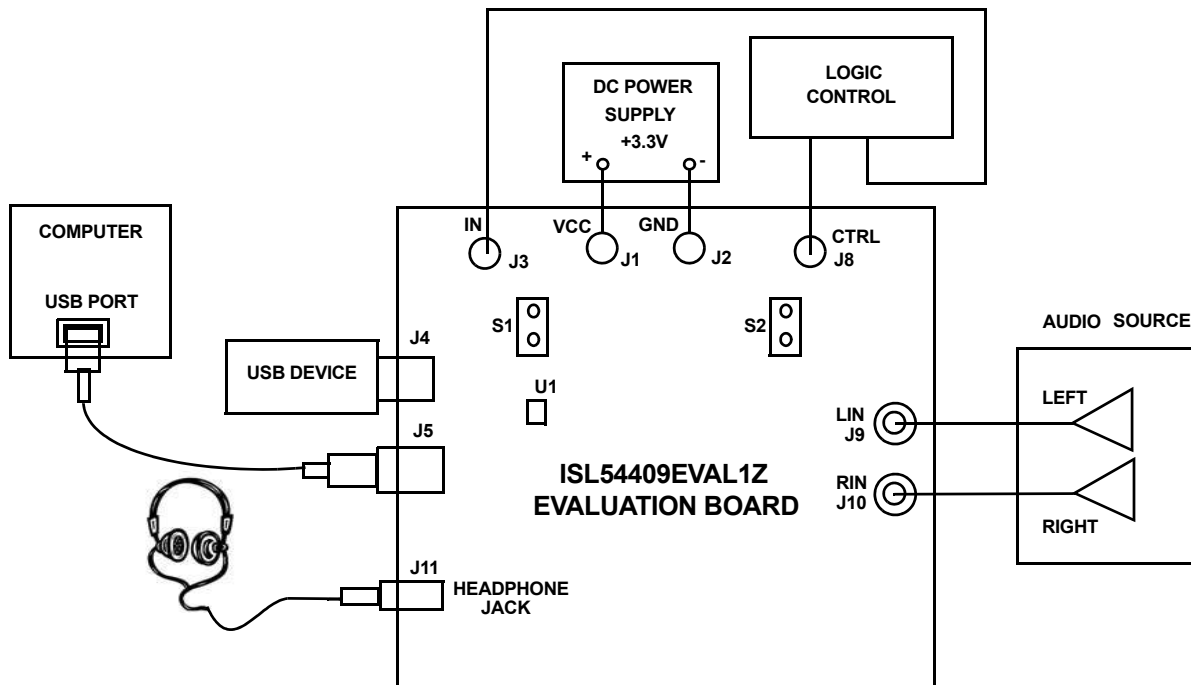

FIGURE 2. BASIC EVALUATION TEST SETUP BLOCK DIAGRAM

## Using The Board (Refer to Figure 2)

### Lab Equipment

The equipment, external supplies and signal sources needed to operate the board are listed as follows:

1. +2.7V to +5.0V DC Power Supply
2. Stereo Audio Source (MP3/Radio/CD Player) or Audio Generator
3. Headphone Set or Audio Analyzer/Oscilloscope
4. Standard USB 2.0 Cables
5. Computer with USB Host Port
6. USB Device (i.e. USB Memory Stick, MP3 Player with USB Port, etc.)

### Initial Board Setup Procedure

1. Attach the main evaluation board to a DC power supply at J1 (VCC) and J12 (GND). The supply should be capable of delivering 2.7V to 5.0V and 100 $\mu$ A of current.
2. Connect the stereo audio source left channel to J9 BNC connector and right channel to J10 BNC connector.
3. Connect the USB device to the USB type A receptacle J4.
4. Connect a USB Host using a standard USB 2.0 Cable to the USB type B receptacle J5.

### Audio Mode Operation

1. Install a headphone into the headphone jack, J11.
2. Logic Control: Put CTRL = Logic "1" and IN = Logic "0". You will now be in Audio mode (3 $\Omega$  audio switches are ON).
3. Turn the audio source ON. You should hear the audio signal in the headphones.

### USB Mode Operation

1. Turn OFF audio stereo source.
2. Remove headphone from J11 Headphone Jack.
3. Logic Control: Put IN = Logic "1". You will now be in USB mode (3 $\Omega$  Audio switches are OFF).
4. The computer should indicate that it is connected to the USB device at the J4 receptacle. You will now be able to send and receive data between the computer and USB device.

If you disconnect the USB cable from J1 and take the IN pin LOW, the IC will return to Audio mode. You can now plug the headphone set into headphone jack, turn the audio source ON to once again play music.

# ISL54409EVAL1Z Evaluation Board Schematic

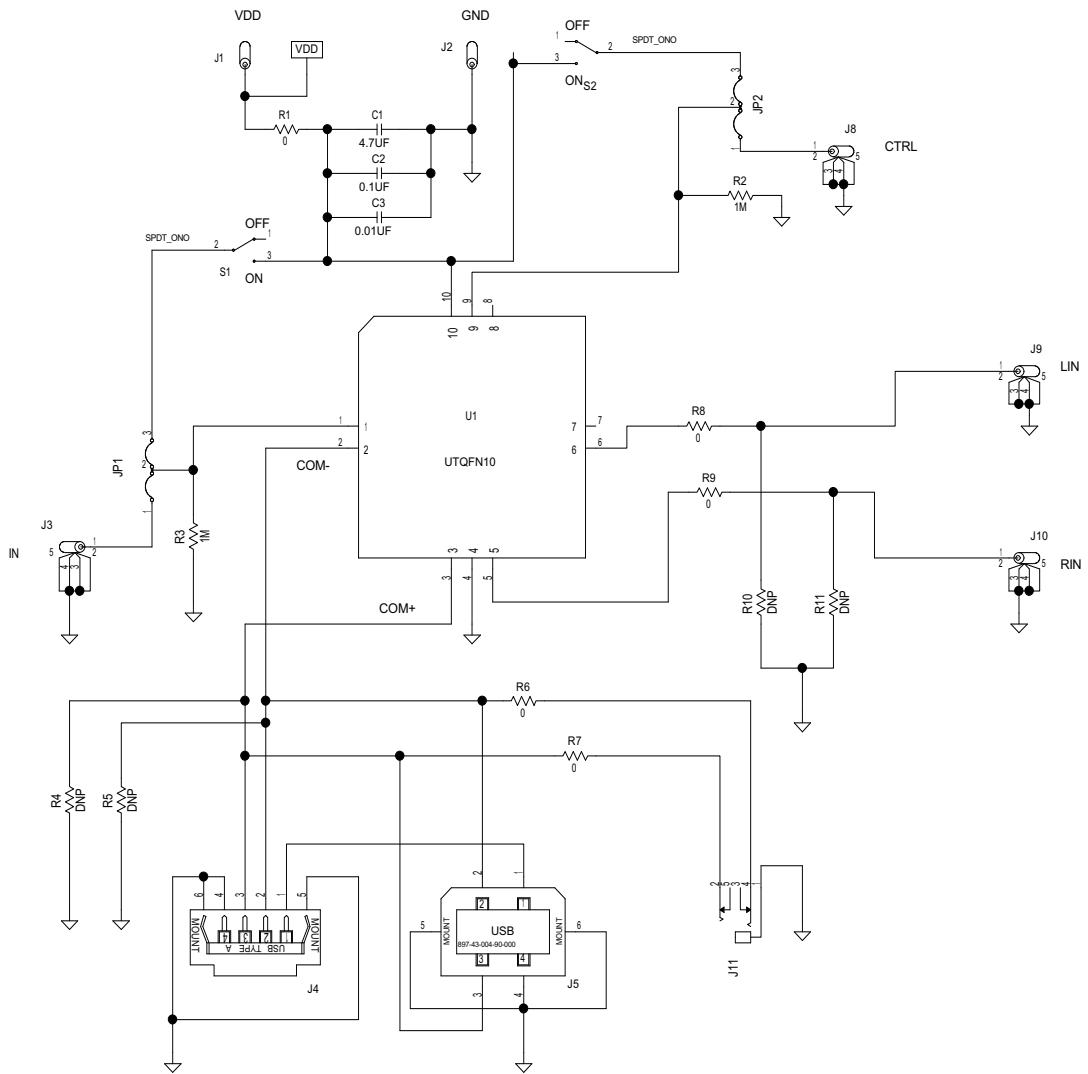

## Notice

1. Descriptions of circuits, software and other related information in this document are provided only to illustrate the operation of semiconductor products and application examples. You are fully responsible for the incorporation or any other use of the circuits, software, and information in the design of your product or system. Renesas Electronics disclaims any and all liability for any losses and damages incurred by you or third parties arising from the use of these circuits, software, or information.
2. Renesas Electronics hereby expressly disclaims any warranties against and liability for infringement or any other claims involving patents, copyrights, or other intellectual property rights of third parties, by or arising from the use of Renesas Electronics products or technical information described in this document, including but not limited to, the product data, drawings, charts, programs, algorithms, and application examples.
3. No license, express, implied or otherwise, is granted hereby under any patents, copyrights or other intellectual property rights of Renesas Electronics or others.
4. You shall not alter, modify, copy, or reverse engineer any Renesas Electronics product, whether in whole or in part. Renesas Electronics disclaims any and all liability for any losses or damages incurred by you or third parties arising from such alteration, modification, copying or reverse engineering.
5. Renesas Electronics products are classified according to the following two quality grades: "Standard" and "High Quality". The intended applications for each Renesas Electronics product depends on the product's quality grade, as indicated below.  
"Standard": Computers; office equipment; communications equipment; test and measurement equipment; audio and visual equipment; home electronic appliances; machine tools; personal electronic equipment; industrial robots; etc.  
"High Quality": Transportation equipment (automobiles, trains, ships, etc.); traffic control (traffic lights); large-scale communication equipment; key financial terminal systems; safety control equipment; etc.  
Unless expressly designated as a high reliability product or a product for harsh environments in a Renesas Electronics data sheet or other Renesas Electronics document, Renesas Electronics products are not intended or authorized for use in products or systems that may pose a direct threat to human life or bodily injury (artificial life support devices or systems; surgical implantations; etc.), or may cause serious property damage (space system; undersea repeaters; nuclear power control systems; aircraft control systems; key plant systems; military equipment; etc.). Renesas Electronics disclaims any and all liability for any damages or losses incurred by you or any third parties arising from the use of any Renesas Electronics product that is inconsistent with any Renesas Electronics data sheet, user's manual or other Renesas Electronics document.
6. When using Renesas Electronics products, refer to the latest product information (data sheets, user's manuals, application notes, "General Notes for Handling and Using Semiconductor Devices" in the reliability handbook, etc.), and ensure that usage conditions are within the ranges specified by Renesas Electronics with respect to maximum ratings, operating power supply voltage range, heat dissipation characteristics, installation, etc. Renesas Electronics disclaims any and all liability for any malfunctions, failure or accident arising out of the use of Renesas Electronics products outside of such specified ranges.
7. Although Renesas Electronics endeavors to improve the quality and reliability of Renesas Electronics products, semiconductor products have specific characteristics, such as the occurrence of failure at a certain rate and malfunctions under certain use conditions. Unless designated as a high reliability product or a product for harsh environments in a Renesas Electronics data sheet or other Renesas Electronics document, Renesas Electronics products are not subject to radiation resistance design. You are responsible for implementing safety measures to guard against the possibility of bodily injury, injury or damage caused by fire, and/or danger to the public in the event of a failure or malfunction of Renesas Electronics products, such as safety design for hardware and software, including but not limited to redundancy, fire control and malfunction prevention, appropriate treatment for aging degradation or any other appropriate measures. Because the evaluation of microcomputer software alone is very difficult and impractical, you are responsible for evaluating the safety of the final products or systems manufactured by you.
8. Please contact a Renesas Electronics sales office for details as to environmental matters such as the environmental compatibility of each Renesas Electronics product. You are responsible for carefully and sufficiently investigating applicable laws and regulations that regulate the inclusion or use of controlled substances, including without limitation, the EU RoHS Directive, and using Renesas Electronics products in compliance with all these applicable laws and regulations. Renesas Electronics disclaims any and all liability for damages or losses occurring as a result of your noncompliance with applicable laws and regulations.
9. Renesas Electronics products and technologies shall not be used for or incorporated into any products or systems whose manufacture, use, or sale is prohibited under any applicable domestic or foreign laws or regulations. You shall comply with any applicable export control laws and regulations promulgated and administered by the governments of any countries asserting jurisdiction over the parties or transactions.
10. It is the responsibility of the buyer or distributor of Renesas Electronics products, or any other party who distributes, disposes of, or otherwise sells or transfers the product to a third party, to notify such third party in advance of the contents and conditions set forth in this document.
11. This document shall not be reprinted, reproduced or duplicated in any form, in whole or in part, without prior written consent of Renesas Electronics.
12. Please contact a Renesas Electronics sales office if you have any questions regarding the information contained in this document or Renesas Electronics products.  
(Note 1) "Renesas Electronics" as used in this document means Renesas Electronics Corporation and also includes its directly or indirectly controlled subsidiaries.  
(Note 2) "Renesas Electronics product(s)" means any product developed or manufactured by or for Renesas Electronics.

(Rev.4.0-1 November 2017)



### SALES OFFICES

Renesas Electronics Corporation

<http://www.renesas.com>

Refer to "<http://www.renesas.com/>" for the latest and detailed information.

**Renesas Electronics America Inc.**  
1001 Murphy Ranch Road, Milpitas, CA 95035, U.S.A.  
Tel: +1-408-432-8888, Fax: +1-408-434-5351

**Renesas Electronics Canada Limited**  
9251 Yonge Street, Suite 8309 Richmond Hill, Ontario Canada L4C 9T3  
Tel: +1-905-237-2004

**Renesas Electronics Europe Limited**  
Dukes Meadow, Millboard Road, Bourne End, Buckinghamshire, SL8 5FH, U.K  
Tel: +44-1628-651-700, Fax: +44-1628-651-804

**Renesas Electronics Europe GmbH**  
Arcadiastrasse 10, 40472 Düsseldorf, Germany  
Tel: +49-211-6503-0, Fax: +49-211-6503-1327

**Renesas Electronics (China) Co., Ltd.**  
Room 1709 Quantum Plaza, No.27 ZhichunLu, Haidian District, Beijing, 100191 P. R. China  
Tel: +86-10-8235-1155, Fax: +86-10-8235-7679

**Renesas Electronics (Shanghai) Co., Ltd.**  
Unit 301, Tower A, Central Towers, 555 Langao Road, Putuo District, Shanghai, 200333 P. R. China  
Tel: +86-21-2226-0888, Fax: +86-21-2226-0999

**Renesas Electronics Hong Kong Limited**  
Unit 1601-1611, 16/F., Tower 2, Grand Century Place, 193 Prince Edward Road West, Mongkok, Kowloon, Hong Kong  
Tel: +852-2265-6688, Fax: +852-2886-9022

**Renesas Electronics Taiwan Co., Ltd.**  
13F, No. 363, Fu Shing North Road, Taipei 10543, Taiwan  
Tel: +886-2-8175-9600, Fax: +886-2-8175-9670

**Renesas Electronics Singapore Pte. Ltd.**  
80 Bendemeer Road, Unit #06-02 Hyflux Innovation Centre, Singapore 339949  
Tel: +65-6213-0200, Fax: +65-6213-0300

**Renesas Electronics Malaysia Sdn.Bhd.**  
Unit 1207, Block B, Menara Amcorp, Amcorp Trade Centre, No. 18, Jln Persiaran Barat, 46050 Petaling Jaya, Selangor Darul Ehsan, Malaysia  
Tel: +60-3-7955-9390, Fax: +60-3-7955-9510

**Renesas Electronics India Pvt. Ltd.**  
No.777C, 100 Feet Road, HAL 2nd Stage, Indiranagar, Bangalore 560 038, India  
Tel: +91-80-67208700, Fax: +91-80-67208777

**Renesas Electronics Korea Co., Ltd.**  
17F, KAMCO Yangjae Tower, 262, Gangnam-daero, Gangnam-gu, Seoul, 06265 Korea  
Tel: +82-2-558-3737, Fax: +82-2-558-5338