

Features

- Asynchronous first-in first-out (FIFO) buffer memories
- 256 x 9 (CY7C419)
- 512 x 9 (CY7C421)
- 1K x 9 (CY7C425)
- 2K x 9 (CY7C429)
- 4K x 9 (CY7C433)
- Dual-ported RAM cell
- High speed 50 MHz read and write independent of depth and width
- Low operating power: $I_{CC} = 35 \text{ mA}$
- Empty and full flags (Half Full flag in standalone)
- TTL compatible
- Retransmit in standalone
- Expandable in width
- PLCC, 7x7 TQFP, SOJ, 300-mil, and 600-mil DIP
- Pb-free packages available
- Pin compatible and functionally equivalent to IDT7200, IDT7201, IDT7202, IDT7203, IDT7204, AM7200, AM7201, AM7202, AM7203, and AM7204

Functional Description

The CY7C419, CY7C420/1, CY7C424/5, CY7C428/9, and CY7C432/3 are first-in first-out (FIFO) memories offered in 600-mil wide and 300-mil wide packages. There are 256, 512, 1,024, 2,048, and 4,096 words respectively by 9 bits wide. Each FIFO memory is organized such that the data is read in the same sequential order that it was written. Full and empty flags are provided to prevent overrun and underrun. Three additional pins are also provided to facilitate unlimited expansion in width, depth, or both. The depth expansion technique steers the control signals from one device to another in parallel. This eliminates the serial addition of propagation delays, so that throughput is not reduced. Data is steered in a similar manner.

The read and write operations may be asynchronous; each can occur at a rate of 50 MHz. The write operation occurs when the write (\overline{W}) signal is LOW. Read occurs when read (\overline{R}) goes LOW. The nine data outputs go to the high impedance state when \overline{R} is HIGH.

A Half Full (\overline{HF}) output flag that is valid in the standalone and width expansion configurations is provided. In the depth expansion configuration, this pin provides the expansion out (XO) information that is used to tell the next FIFO that it is activated.

In the standalone and width expansion configurations, a LOW on the retransmit (\overline{RT}) input causes the FIFOs to retransmit the data. Read enable (\overline{R}) and write enable (\overline{W}) must both be HIGH during retransmit, and then \overline{R} is used to access the data.

The CY7C419, CY7C420, CY7C421, CY7C424, CY7C425, CY7C428, CY7C429, CY7C432, and CY7C433 are fabricated using an advanced 0.65-micron P-well CMOS technology. Input ESD protection is greater than 2000V and latch-up is prevented by careful layout and guard rings.

Logic Block Diagram

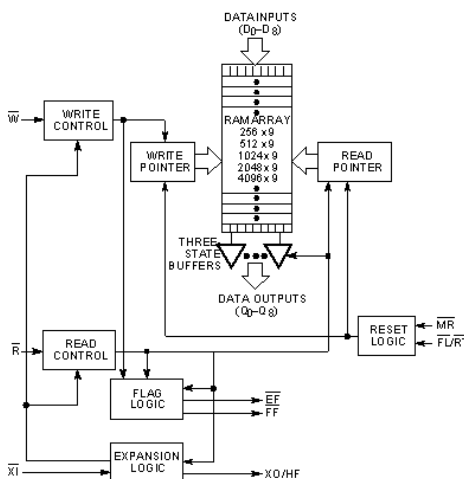

Pin Configurations

Figure 1. 32-Pin PLCC/LCC

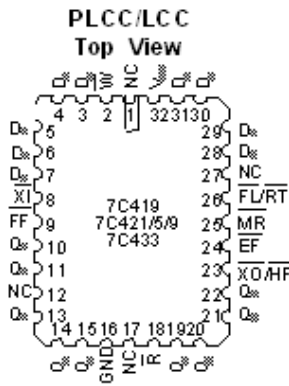

Figure 3. 32-Pin TQFP

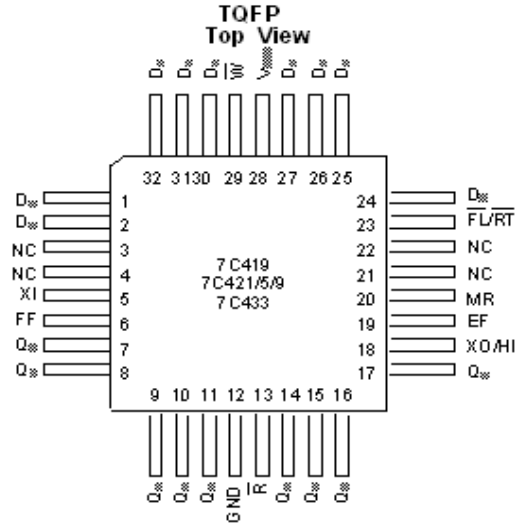

Figure 2. 28-Pin DIP

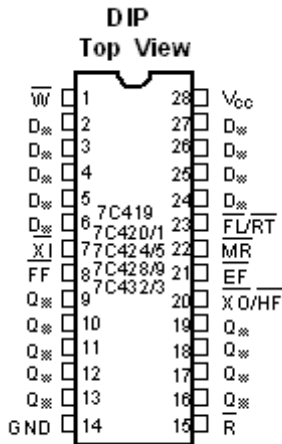

Table 1. Selection Guide

4K x 9	-10	-15	-20	-25	-30	-40	-65
Frequency (MHz)	50	40	33.3	28.5	25	20	12.5
Maximum Access Time (ns)	10	15	20	25	30	40	65
I _{CC1} (mA)	35	35	35	35	35	35	35

Maximum Rating

Exceeding maximum ratings may impair the useful life of the device. These user guidelines are not tested.^[1]

- Storage Temperature -65°C to +150°C
- Ambient Temperature with Power Applied.. -55°C to +125°C
- Supply Voltage to Ground Potential..... -0.5V to +7.0V
- DC Voltage Applied to Outputs in High Z State -0.5V to +7.0V
- DC Input Voltage -0.5V to +7.0V
- Power Dissipation 1.0W

- Output Current, into Outputs (LOW)..... 20 mA
- Static Discharge Voltage..... >2000V (per MIL-STD-883, Method 3015)
- Latch-Up Current..... >200 mA

Operating Range

Range	Ambient Temperature ^[2]	V _{CC}
Commercial	0°C to + 70°C	5V ± 10%
Industrial	-40°C to +85°C	5V ± 10%

Electrical Characteristics Over the Operating Range^[3]

Parameter	Description	Test Conditions	All Speed Grades		Unit	
			Min	Max		
V _{OH}	Output HIGH Voltage	V _{CC} = Min., I _{OH} = -2.0 mA	2.4		V	
V _{OL}	Output LOW Voltage	V _{CC} = Min., I _{OL} = 8.0 mA		0.4	V	
V _{IH}	Input HIGH Voltage		Commercial	2.0	V _{CC}	V
			Industrial	2.2	V _{CC}	
V _{IL}	Input LOW Voltage		^[4]	0.8	V	
I _{IX}	Input Leakage Current	GND ≤ V _I ≤ V _{CC}	-10	+10	μA	
I _{OZ}	Output Leakage Current	$\bar{R} \geq V_{IH}$, GND ≤ V _O ≤ V _{CC}	-10	+10	μA	
I _{OS}	Output Short Circuit Current ^[5]	V _{CC} = Max., V _{OUT} = GND		-90	mA	

Notes

1. Single Power Supply: The voltage on any input or I/O pin can not exceed the power pin during power-up.
2. T_A is the "instant on" case temperature.
3. See the last page of this specification for Group A subgroup testing information.
4. V_{IL} (Min.) = -2.0V for pulse durations of less than 20 ns.
5. For test purposes, not more than one output at a time should be shorted. Short circuit test duration should not exceed 30 seconds.

Electrical Characteristics Over the Operating Range

Parameter	Description	Test Conditions	-10		-15		-20		-25		Unit	
			Min	Max	Min	Max	Min	Max	Min	Max		
I _{CC}	Operating Current	V _{CC} = Max., I _{OUT} = 0 mA f = f _{MAX}	Commercial		85		65		55		50	mA
			Industrial				100		90		80	
I _{CC1}	Operating Current	V _{CC} = Max., I _{OUT} = 0 mA F = 20 MHz	Commercial		35		35		35		35	mA
I _{SB1}	Standby Current	All Inputs = V _{IH} Min.	Commercial		10		10		10		10	mA
			Industrial				15		15		15	
I _{SB2}	Power-Down Current	All Inputs ≥ V _{CC} - 0.2V	Commercial		5		5		5		5	mA
			Industrial				8		8		8	

Electrical Characteristics Over the Operating Range^[3]

Parameter	Description	Test Conditions	-30		-40		-65		Unit	
			Min	Max	Min	Max	Min	Max		
I _{CC}	Operating Current	V _{CC} = Max., I _{OUT} = 0 mA f = f _{MAX}	Commercial		40		35		35	mA
			Industrial		75		70		65	
I _{CC1}	Operating Current	V _{CC} = Max., I _{OUT} = 0 mA F = 20 MHz	Commercial		35		35		35	mA
I _{SB1}	Standby Current	All Inputs = V _{IH} Min.	Commercial		10		10		10	mA
			Industrial		15		15		15	
I _{SB2}	Power-Down Current	All Inputs ≥ V _{CC} - 0.2V	Commercial		5		5		5	mA
			Industrial		8		8		8	

Capacitance^[6]

Parameter	Description	Test Conditions	Max	Unit
C _{IN}	Input Capacitance	T _A = 25°C, f = 1 MHz, V _{CC} = 4.5V	6	pF
C _{OUT}	Output Capacitance		6	pF

Note

6. Tested initially and after any design or process changes that may affect these parameters.

Switching Characteristics Over the Operating Range^[7, 8]

Parameter	Description	-10		-15		-20		-25		Unit
		Min	Max	Min	Max	Min	Max	Min	Max	
t _{RC}	Read Cycle Time	20		25		30		35		ns
t _A	Access Time		10		15		20		25	ns
t _{RR}	Read Recovery Time	10		10		10		10		ns
t _{PR}	Read Pulse Width	10		15		20		25		ns
t _{LZR} ^[6,9]	Read LOW to Low Z	3		3		3		3		ns
t _{DVR} ^[9,10]	Data Valid After Read HIGH	5		5		5		5		ns
t _{HZR} ^[6,9,10]	Read HIGH to High Z		15		15		15		18	ns
t _{WC}	Write Cycle Time	20		25		30		35		ns
t _{PW}	Write Pulse Width	10		15		20		25		ns
t _{HWZ} ^[6,9]	Write HIGH to Low Z	5		5		5		5		ns
t _{WR}	Write Recovery Time	10		10		10		10		ns
t _{SD}	Data Set-Up Time	6		8		12		15		ns
t _{HD}	Data Hold Time	0		0		0		0		ns
t _{MRSC}	MR Cycle Time	20		25		30		35		ns
t _{PMR}	MR Pulse Width	10		15		20		25		ns
t _{RMR}	MR Recovery Time	10		10		10		10		ns
t _{RPW}	Read HIGH to MR HIGH	10		15		20		25		ns
t _{WPW}	Write HIGH to MR HIGH	10		15		20		25		ns
t _{RTC}	Retransmit Cycle Time	20		25		30		35		ns
t _{PRT}	Retransmit Pulse Width	10		15		20		25		ns
t _{RTR}	Retransmit Recovery Time	10		10		10		10		ns
t _{EFL}	MR to EF LOW		20		25		30		35	ns
t _{HFH}	MR to HF HIGH		20		25		30		35	ns
t _{FFH}	MR to FF HIGH		20		25		30		35	ns
t _{REF}	Read LOW to EF LOW		10		15		20		25	ns
t _{RFF}	Read HIGH to FF HIGH		10		15		20		25	ns
t _{WEF}	Write HIGH to EF HIGH		10		15		20		25	ns
t _{WFF}	Write LOW to FF LOW		10		15		20		25	ns
t _{WHF}	Write LOW to HF LOW		10		15		20		25	ns
t _{RHF}	Read HIGH to HF HIGH		10		15		20		25	ns
t _{RAE}	Effective Read from Write HIGH		10		15		20		25	ns
t _{RPE}	Effective Read Pulse Width After EF HIGH	10		15		20		25		ns
t _{WAF}	Effective Write from Read HIGH		10		15		20		25	ns
t _{WPF}	Effective Write Pulse Width After FF HIGH	10		15		20		25		ns
t _{XOL}	Expansion Out LOW Delay from Clock		10		15		20		25	ns
t _{XOH}	Expansion Out HIGH Delay from Clock		10		15		20		25	ns

Notes

7. Test conditions assume signal transition time of 3 ns or less, timing reference levels of 1.5V and output loading of the specified I_{OL}/I_{OH} and 30 pF load capacitance, as in part (a) of AC Test Load and Waveforms, unless otherwise specified.
8. See the last page of this specification for Group A subgroup testing information.
9. t_{HZR} transition is measured at +200 mV from V_{OL} and -200 mV from V_{OH}. t_{DVR} transition is measured at the 1.5V level. t_{HWZ} and t_{LZR} transition is measured at ±100 mV from the steady state.
10. t_{HZR} and t_{DVR} use capacitance loading as in part (b) of AC Test Load and Waveforms.

Switching Characteristics Over the Operating Range^[7, 8] (continued)

Parameter	Description	-30		-40		-65		Unit
		Min	Max	Min	Max	Min	Max	
t _{RC}	Read Cycle Time	40		50		80		ns
t _A	Access Time		30		40		65	ns
t _{RR}	Read Recovery Time	10		10		15		ns
t _{PR}	Read Pulse Width	30		40		65		ns
t _{LZR} ^[6,9]	Read LOW to Low Z	3		3		3		ns
t _{DVR} ^[9,10]	Data Valid After Read HIGH	5		5		5		ns
t _{HZR} ^[6,9,10]	Read HIGH to High Z		20		20		20	ns
t _{WC}	Write Cycle Time	40		50		80		ns
t _{PW}	Write Pulse Width	30		40		65		ns
t _{HWZ} ^[6,9]	Write HIGH to Low Z	5		5		5		ns
t _{WR}	Write Recovery Time	10		10		15		ns
t _{SD}	Data Set-Up Time	18		20		30		ns
t _{HD}	Data Hold Time	0		0		0		ns
t _{MRSC}	MR Cycle Time	40		50		80		ns
t _{PMR}	MR Pulse Width	30		40		65		ns
t _{RMR}	MR Recovery Time	10		10		15		ns
t _{RPW}	Read HIGH to MR HIGH	30		40		65		ns
t _{WPW}	Write HIGH to MR HIGH	30		40		65		ns
t _{RTC}	Retransmit Cycle Time	40		50		80		ns
t _{PRT}	Retransmit Pulse Width	30		40		65		ns
t _{RTR}	Retransmit Recovery Time	10		10		15		ns
t _{EFL}	MR to EF LOW		40		50		80	ns
t _{HFH}	MR to HF HIGH		40		50		80	ns
t _{FFH}	MR to FF HIGH		40		50		80	ns
t _{REF}	Read LOW to EF LOW		30		35		60	ns
t _{RFF}	Read HIGH to FF HIGH		30		35		60	ns
t _{WEF}	Write HIGH to EF HIGH		30		35		60	ns
t _{WFF}	Write LOW to FF LOW		30		35		60	ns
t _{WHF}	Write LOW to HF LOW		30		35		60	ns
t _{RHF}	Read HIGH to HF HIGH		30		35		60	ns
t _{RAE}	Effective Read from Write HIGH		30		35		60	ns
t _{RPE}	Effective Read Pulse Width After EF HIGH	30		40		65		ns
t _{WAF}	Effective Write from Read HIGH		30		35		60	ns
t _{WPF}	Effective Write Pulse Width After FF HIGH	30		40		65		ns
t _{XOL}	Expansion Out LOW Delay from Clock		30		40		65	ns
t _{XOH}	Expansion Out HIGH Delay from Clock		30		40		65	ns

Switching Waveforms

Figure 4. Asynchronous Read and Write

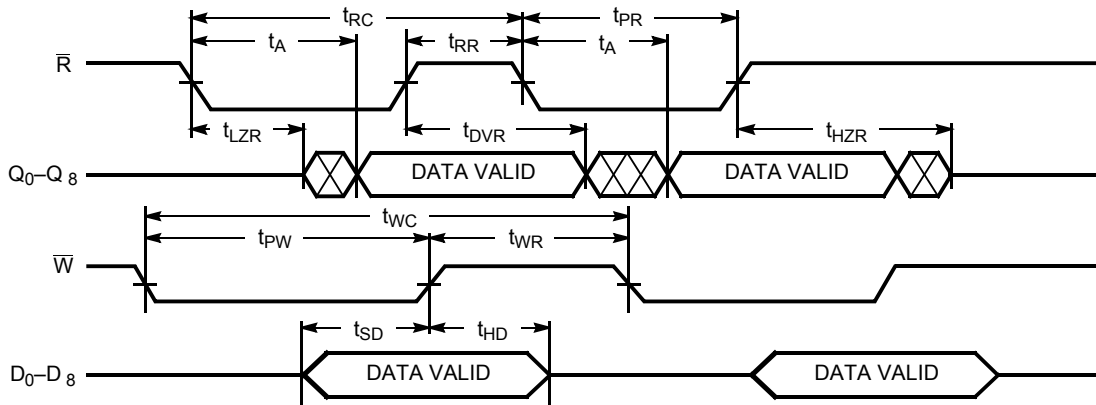

Figure 5. Master Reset

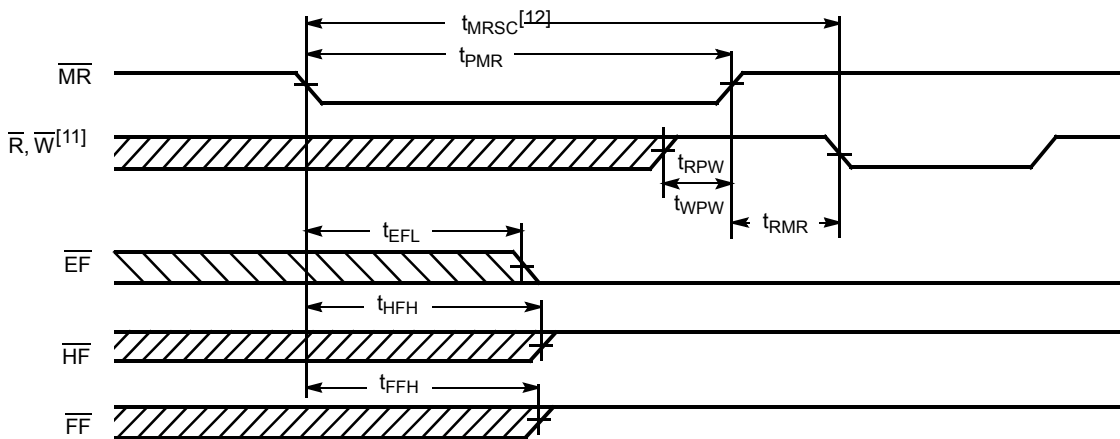
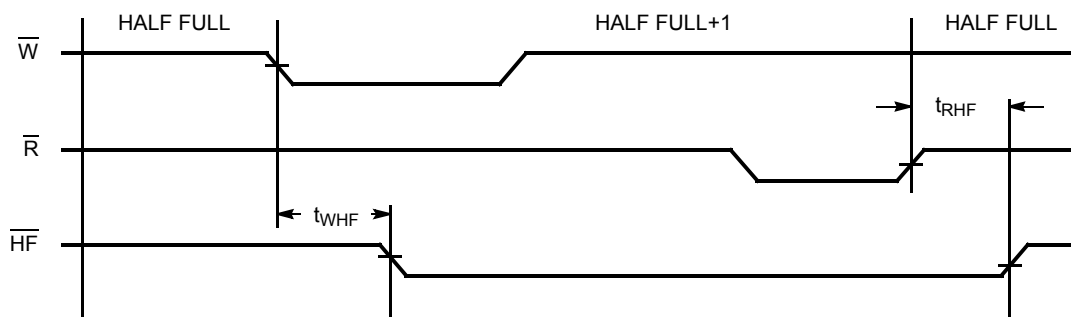

Figure 6. Half-full Flag



Notes

11. \bar{W} and $\bar{R} \geq V_{IH}$ around the rising edge of \bar{MR}

12. $t_{MRSC} = t_{PMR} + t_{RMR}$

Switching Waveforms (continued)

Figure 7. Last Write to First Read Full Flag

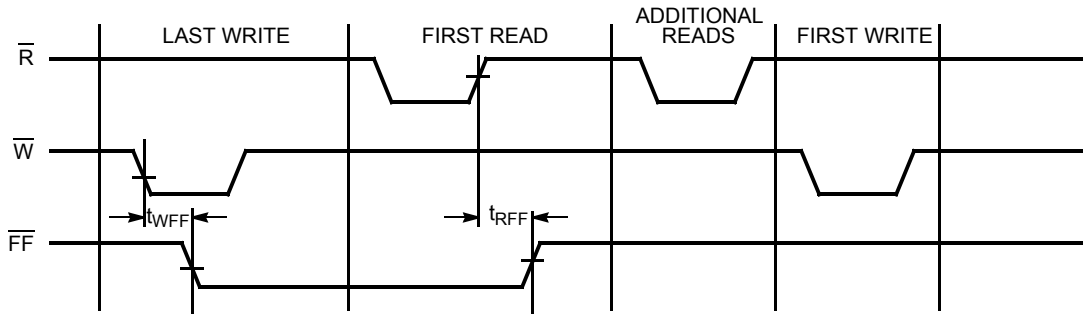

Figure 8. Last Read to First Write Empty Flag

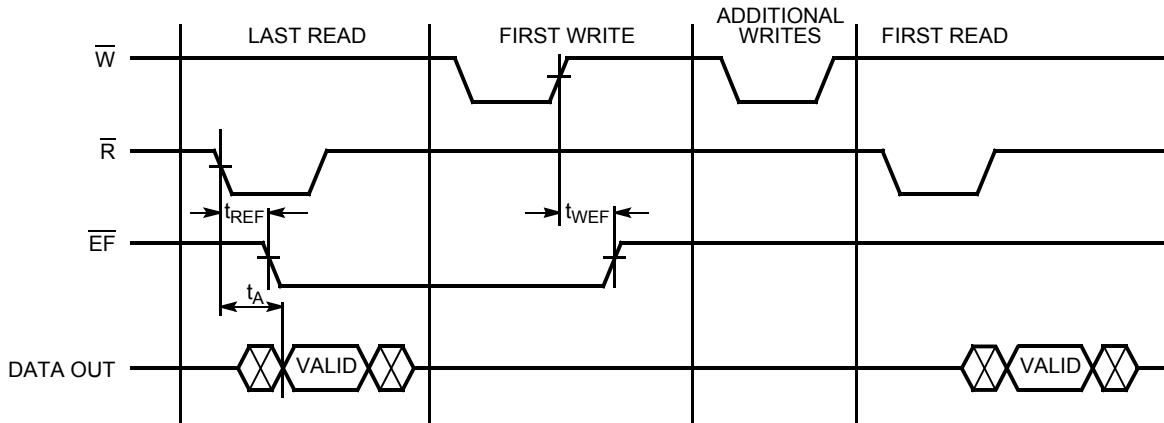
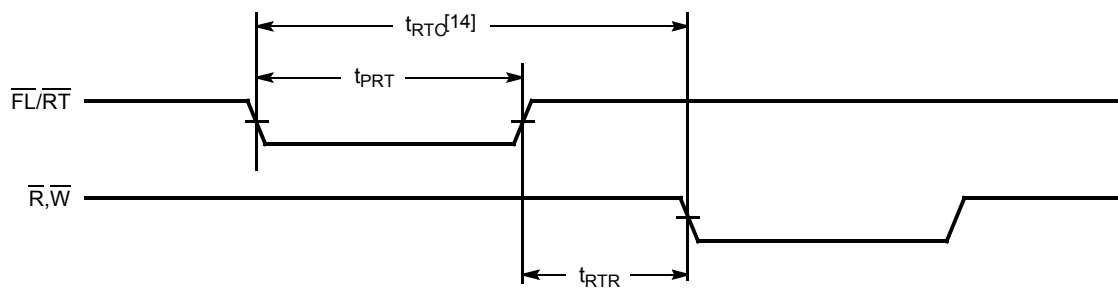

Figure 9. Retransmit^[13]



Notes

- 13. \overline{EF} , \overline{HF} and \overline{FF} may change state during retransmit as a result of the offset of the read and write pointers, but flags will be valid at t_{RTC} .
- 14. $t_{RTC} = t_{PRT} + t_{RTR}$.

Switching Waveforms (continued)

Figure 10. Empty Flag and Read Data Flow-through Mode

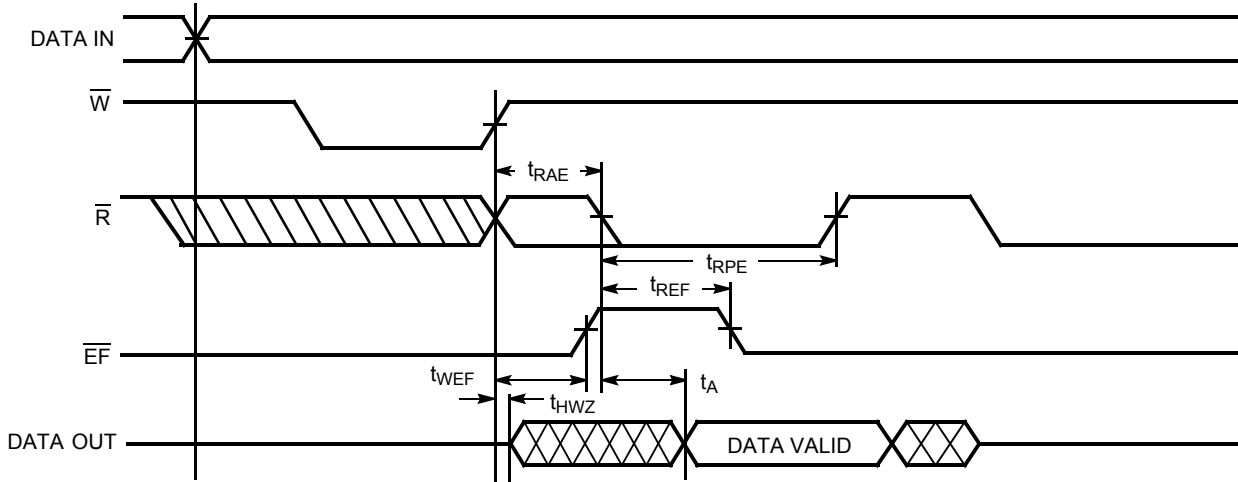
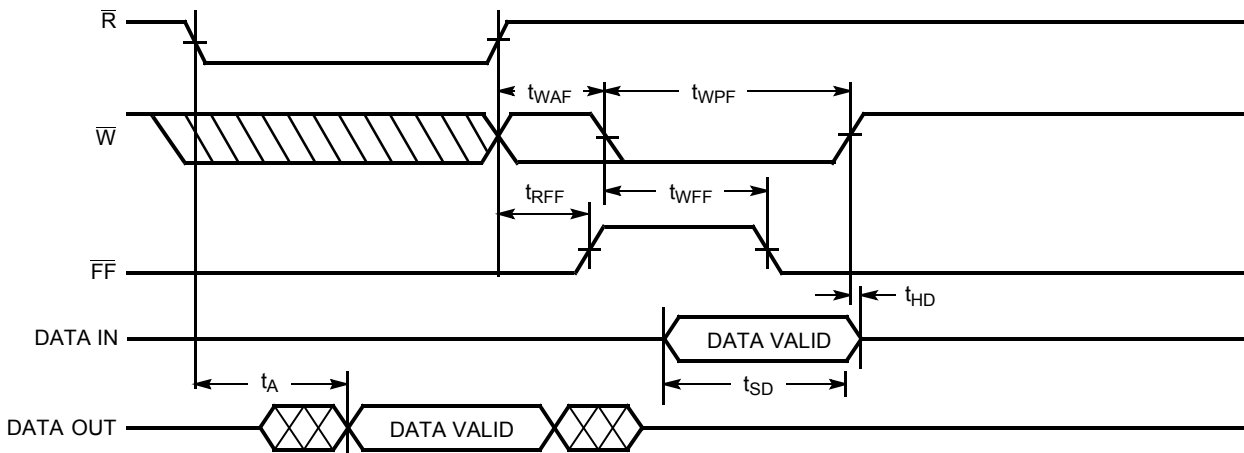
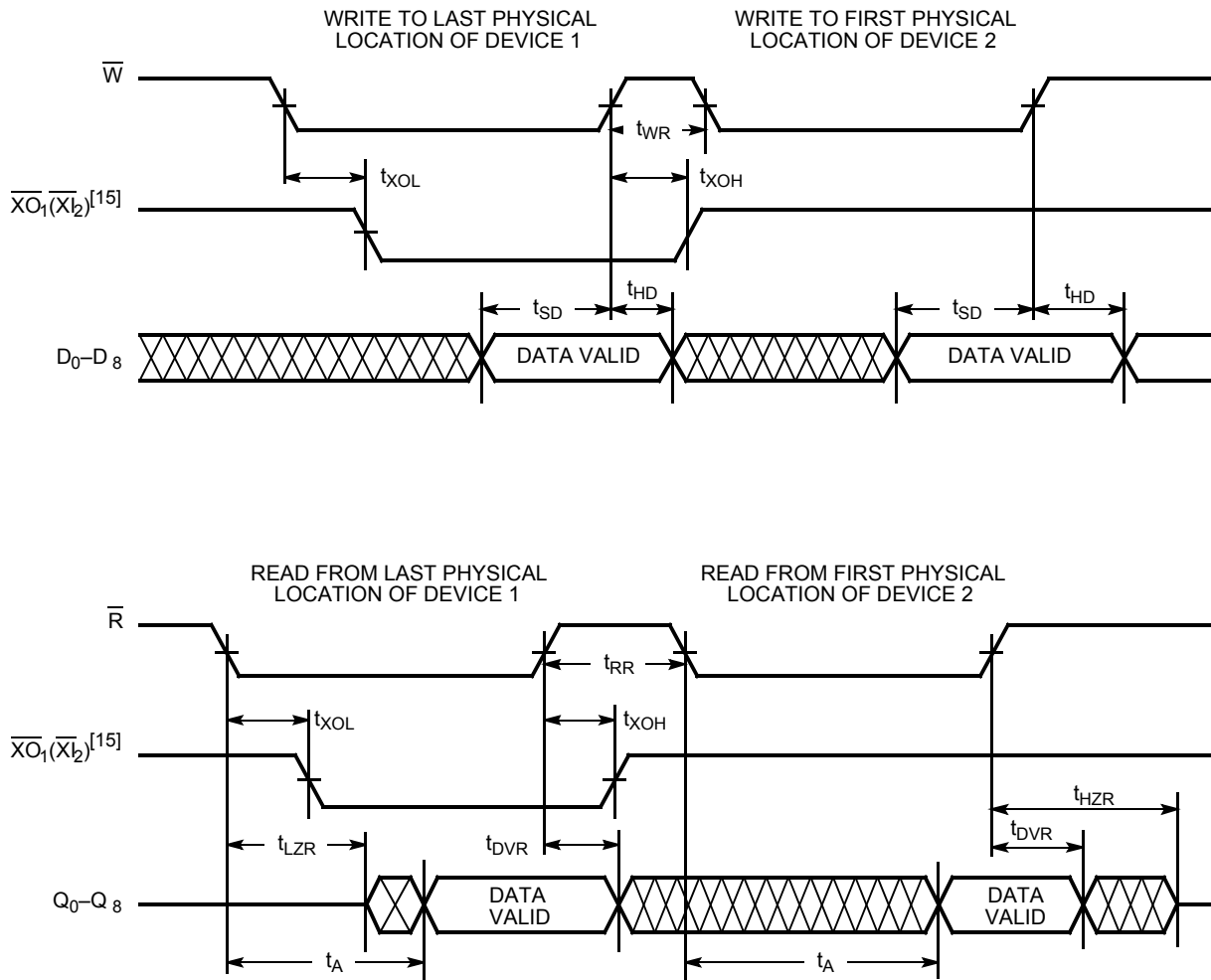

Figure 11. Full Flag and Write Data Flow-through Mode



Switching Waveforms (continued)

Figure 12. Expansion Timing Diagrams



Note

15. Expansion Out of device 1 ($\overline{XO_1}$) is connected to Expansion In of device 2 ($\overline{XI_2}$)

Architecture

The CY7C419, CY7C420/1, CY7C424/5, CY7C428/9, CY7C432/3 FIFOs consist of an array of 256, 512, 1024, 2048, 4096 words of 9 bits each (implemented by an array of dual-port RAM cells), a read pointer, a write pointer, control signals (\overline{W} , \overline{R} , \overline{XI} , \overline{XO} , \overline{FL} , \overline{RT} , \overline{MR}), and Full, Half Full, and Empty flags.

Dual-Port RAM

The dual-port RAM architecture refers to the basic memory cell used in the RAM. The cell itself enables the read and write operations to be independent of each other, which is necessary to achieve truly asynchronous operation of the inputs and outputs. A second benefit is that the time required to increment the read and write pointers is much less than the time required for data propagation through the memory, which is the case if memory is implemented using the conventional register array architecture.

Resetting the FIFO

Upon power up, the FIFO must be reset with a Master Reset (\overline{MR}) cycle. This causes the FIFO to enter the empty condition signified by the Empty flag (\overline{EF}) being LOW, and both the Half Full (\overline{HF}) and Full flags (\overline{FF}) being HIGH. Read (\overline{R}) and write (\overline{W}) must be HIGH t_{RPW}/t_{WPW} before and t_{RMR} after the rising edge of \overline{MR} for a valid reset cycle. If reading from the FIFO after a reset cycle is attempted, the outputs are in the high impedance state.

Writing Data to the FIFO

The availability of at least one empty location is indicated by a HIGH \overline{FF} . The falling edge of \overline{W} initiates a write cycle. Data appearing at the inputs (D_0 – D_8) t_{SD} before and t_{HD} after the rising edge of \overline{W} will be stored sequentially in the FIFO.

The \overline{EF} LOW-to-HIGH transition occurs t_{WEF} after the first LOW-to-HIGH transition of \overline{W} for an empty FIFO. \overline{HF} goes LOW t_{WHF} after the falling edge of \overline{W} following the FIFO actually being Half Full. Therefore, the \overline{HF} is active once the FIFO is filled to half its capacity plus one word. \overline{HF} will remain LOW while less than one half of total memory is available for writing. The LOW-to-HIGH transition of \overline{HF} occurs t_{RHF} after the rising edge of \overline{R} when the FIFO goes from half full +1 to half full. \overline{HF} is available in standalone and width expansion modes. \overline{FF} goes LOW t_{WFF} after the falling edge of \overline{W} , during the cycle in which the last available location is filled. Internal logic prevents overrunning a full FIFO. Writes to a full FIFO are ignored and the write pointer is not incremented. \overline{FF} goes HIGH t_{RFF} after a read from a full FIFO.

Reading Data from the FIFO

The falling edge of \overline{R} initiates a read cycle if the \overline{EF} is not LOW. Data outputs (Q_0 to Q_8) are in a high impedance condition between read operations (\overline{R} HIGH), when the FIFO is empty, or when the FIFO is not the active device in the depth expansion mode.

When one word is in the FIFO, the falling edge of \overline{R} initiates a HIGH-to-LOW transition of \overline{EF} . The rising edge of \overline{R} causes the data outputs to go to the high impedance state and remain such until a write is performed. Reads to an empty FIFO are ignored and do not increment the read pointer. From the empty condition, the FIFO can be read t_{WEF} after a valid write.

The retransmit feature is beneficial when transferring packets of data. It enables the receiver to acknowledge receipt of data and retransmit, if necessary.

The Retransmit (\overline{RT}) input is active in the standalone and width expansion modes. The retransmit feature is intended for use when a number of writes equal to or less than the depth of the FIFO have occurred since the last \overline{MR} cycle. A LOW pulse on \overline{RT} resets the internal read pointer to the first physical location of the FIFO. \overline{R} and \overline{W} must both be HIGH while and t_{RTR} after retransmit is LOW. With every read cycle after retransmit, previously accessed data and not previously accessed data is read and the read pointer is incremented until it is equal to the write pointer. Full, Half Full, and Empty flags are governed by the relative locations of the read and write pointers and are updated during a retransmit cycle. Data written to the FIFO after activation of \overline{RT} are also transmitted. FIFO, up to the full depth, can be repeatedly retransmitted.

Standalone/Width Expansion Modes

Standalone and width expansion modes are set by grounding Expansion In (\overline{XI}) and tying First Load (\overline{FL}) to V_{CC} . FIFOs can be expanded in width to provide word widths greater than nine in increments of nine. During width expansion mode, all control line inputs are common to all devices, and flag outputs from any device can be monitored.

Depth Expansion Mode

Depth expansion mode (see Figure 13 on page 12) is entered when, during a \overline{MR} cycle, Expansion Out (\overline{XO}) of one device is connected to Expansion In (\overline{XI}) of the next device, with \overline{XO} of the last device connected to \overline{XI} of the first device. In the depth expansion mode the First Load (\overline{FL}) input, when grounded, indicates that this part is the first to be loaded. All other devices must have this pin HIGH. To enable the correct FIFO, \overline{XO} is pulsed LOW when the last physical location of the previous FIFO is written to and pulsed LOW again when the last physical location is read. Only one FIFO is enabled for read and one for write at any given time. All other devices are in standby.

FIFOs can also be expanded simultaneously in depth and width. Consequently, any depth or width FIFO can be created of word widths in increments of 9. When expanding in depth, a composite \overline{FF} must be created by ORing the \overline{FFs} together. Likewise, a composite \overline{EF} is created by ORing the \overline{EFs} together. \overline{HF} and \overline{RT} functions are not available in depth expansion mode.

Use of the Empty and Full Flags

To achieve maximum frequency, the flags must be valid at the beginning of the next cycle. However, because they can be updated by either edge of the read or write signal, they must be valid by one-half of a cycle. Cypress FIFOs meet this requirement; some competitors' FIFOs do not.

The reason for why the flags should be valid by the next cycle is complex. The "effective pulse width violation" phenomenon can occur at the full and empty boundary conditions, if the flags are not properly used. The empty flag must be used to prevent reading from an empty FIFO and the full flag must be used to prevent writing into a full FIFO.

For example, consider an empty FIFO that is receiving read pulses. Because the FIFO is empty, the read pulses are ignored by the FIFO, and nothing happens. Next, a single word is written

into the FIFO, with a signal that is asynchronous to the read signal. The (internal) state machine in the FIFO goes from empty to empty+1. However, it does this asynchronously with respect to the read signal, so that the effective pulse width of the read signal cannot be determined, because the state machine does not look at the read signal until it goes to the empty+1 state.

Similarly, the minimum write pulse width may be violated by trying to write into a full FIFO, and asynchronously performing a read. The empty and full flags are used to avoid these effective pulse width violations, but to do this and operate at the maximum frequency, the flag must be valid at the beginning of the next cycle.

Figure 13. Depth Expansion

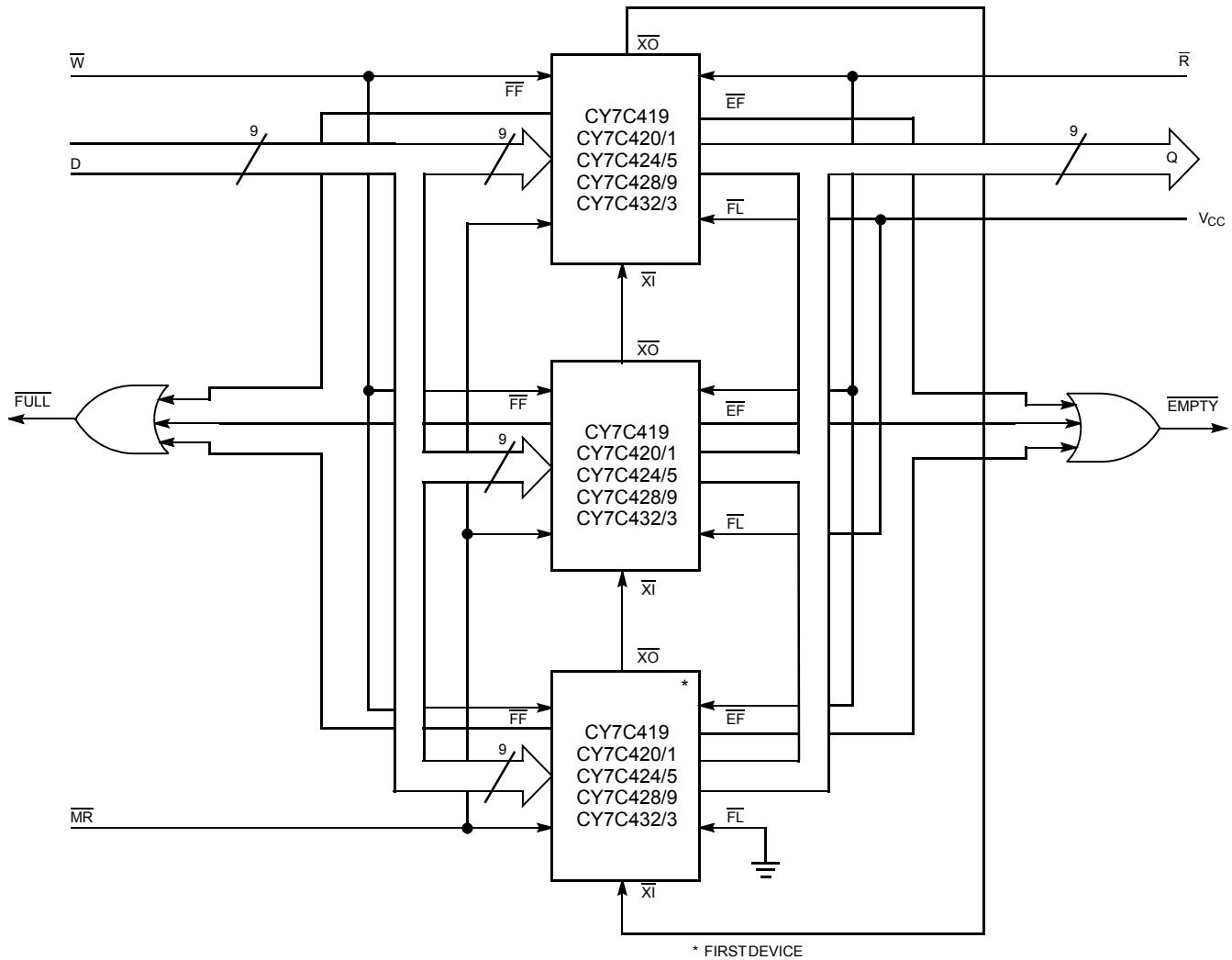

Ordering Information

Speed (ns)	Ordering Code	Package Type	Package Type	Operating Range
10	CY7C421-10AC	A32	32-Pin Thin Plastic Quad Flatpack	Commercial
	CY7C421-10JC	J65	32-Pin Plastic Leaded Chip Carrier	
	CY7C421-10JXC	J65	32-Pin Pb-Free Plastic Leaded Chip Carriers	
	CY7C421-10PC	P21	28-Pin (300-Mil) Molded DIP	
	CY7C421-10VC	V21	28-Pin (300-Mil) Molded SOJ	
15	CY7C421-15AC	A32	32-Pin Thin Plastic Quad Flatpack	Commercial
	CY7C421-15AXC	A32	32-Pin Pb-Free Thin Plastic Quad Flatpack	
	CY7C421-15JC	J65	32-Pin Plastic Leaded Chip Carrier	Industrial
	CY7C421-15JI	J65	32-Pin Plastic Leaded Chip Carrier	
	CY7C421-15VI	V21	28-Pin (300-Mil) Molded SOJ	
20	CY7C421-20JC	J65	32-Pin Plastic Leaded Chip Carrier	Commercial
	CY7C421-20JXC	J65	32-Pin Pb-Free Plastic Leaded Chip Carriers	
	CY7C421-20PC	P21	28-Pin (300-Mil) Molded DIP	
	CY7C421-20VC	V21	28-Pin (300-Mil) Molded SOJ	
	CY7C421-20VXC	V21	28-Pin (300-Mil) Pb-Free Molded SOJ	
	CY7C421-20JI	J65	32-Pin Plastic Leaded Chip Carrier	Industrial
	CY7C421-20JXI	J65	32-Pin Plastic Leaded Chip Carrier	
25	CY7C421-25JC	J65	32-Pin Plastic Leaded Chip Carrier	Commercial
	CY7C421-25PC	P21	28-Pin (300-Mil) Molded DIP	
	CY7C421-25VC	V21	28-Pin (300-Mil) Molded SOJ	
	CY7C421-25JI	J65	32-Pin Plastic Leaded Chip Carrier	Industrial
	CY7C421-25PI	P21	28-Pin (300-Mil) Molded DIP	
30	CY7C421-30JC	J65	32-Pin Plastic Leaded Chip Carrier	Commercial
	CY7C421-30PC	P21	28-Pin (300-Mil) Molded DIP	
	CY7C421-30JI	J65	32-Pin Plastic Leaded Chip Carrier	Industrial
40	CY7C421-40JC	J65	32-Pin Plastic Leaded Chip Carrier	Commercial
	CY7C421-40PC	P21	28-Pin (300-Mil) Molded DIP	
	CY7C421-40VC	V21	28-Pin (300-Mil) Molded SOJ	
	CY7C421-40JI	J65	32-Pin Plastic Leaded Chip Carrier	Industrial
65	CY7C421-65JC	J65	32-Pin Plastic Leaded Chip Carrier	Commercial
	CY7C421-65PC	P21	28-Pin (300-Mil) Molded DIP	
	CY7C421-65VC	V21	28-Pin (300-Mil) Molded SOJ	
	CY7C421-65JI	J65	32-Pin Plastic Leaded Chip Carrier	Industrial

Package Diagrams

Figure 14. 32-Pin Thin Plastic Quad Flat Pack A32 (51-85063)

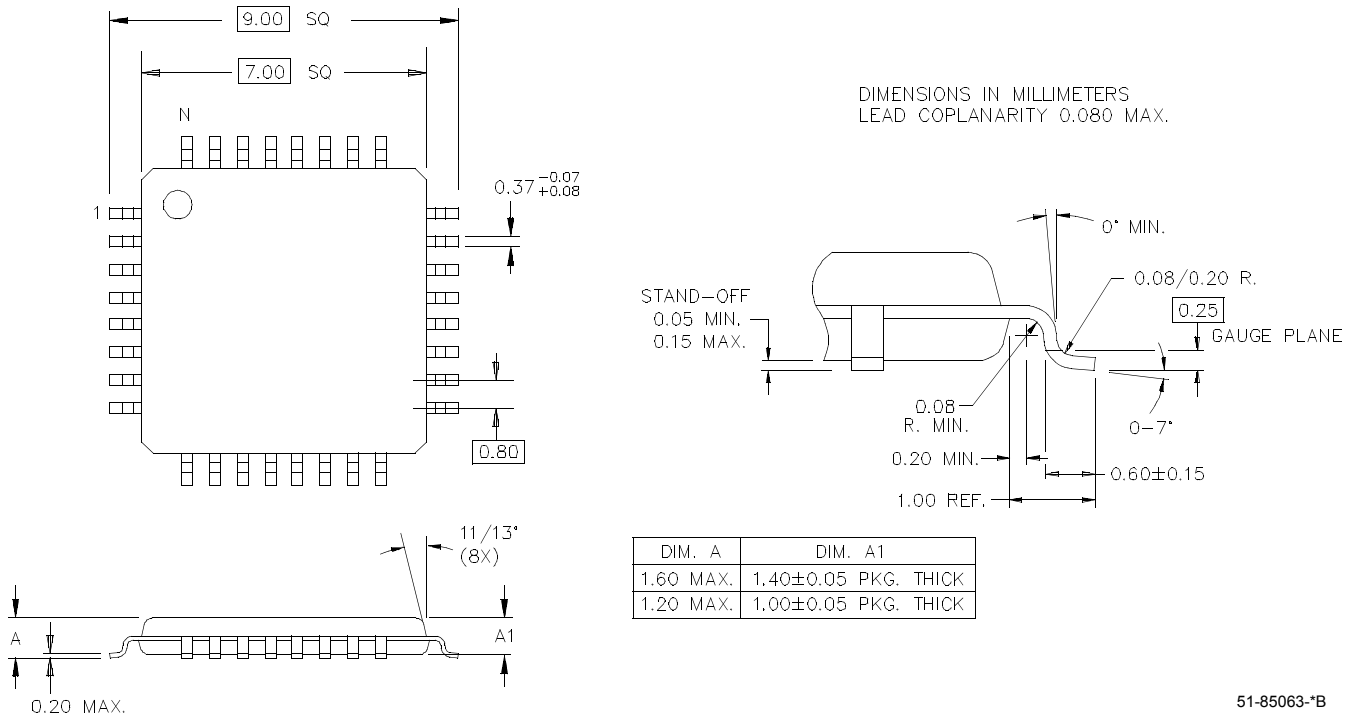
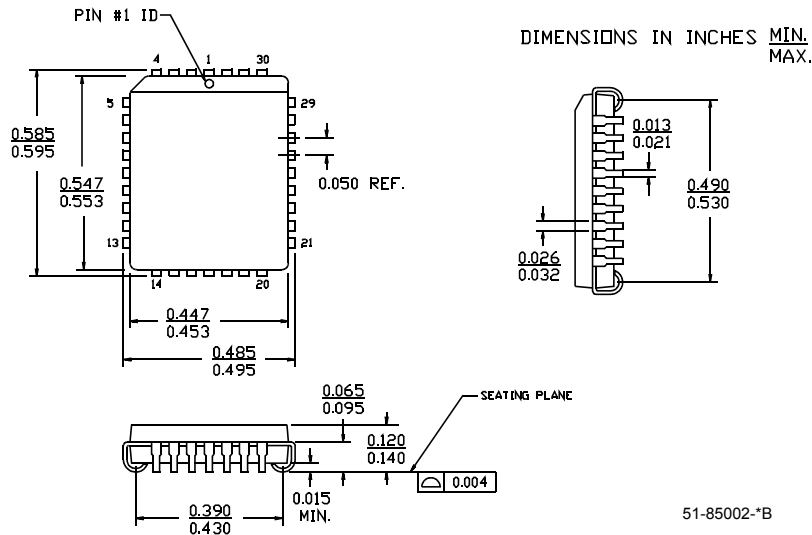
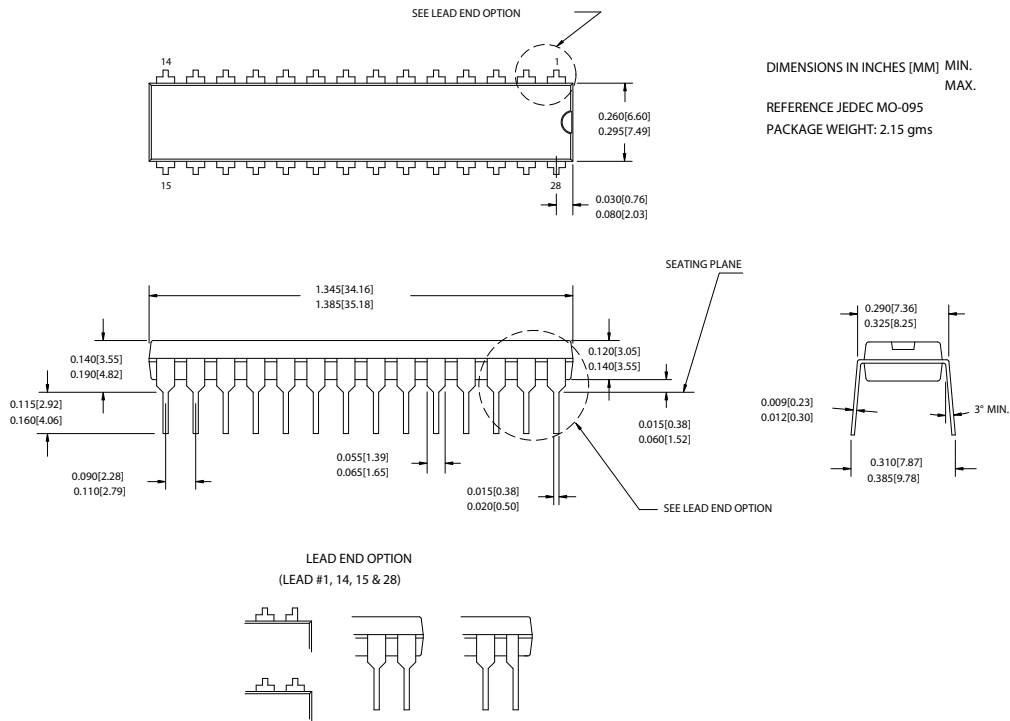

Figure 15. 32-Pin Plastic Leaded Chip Carrier J65 (51-85002)



Package Diagrams (continued)

Figure 16. 28-Pin (300-Mil) PDIP P21 (51-85014)



51-85014-*D

Package Diagrams (continued)

Figure 17. 28-Pin (300-Mil) Molded SOJ V21(51-85031)

NOTE 1

1. JEDEC STD REF MO088
2. BODY LENGTH DIMENSION DOES NOT INCLUDE MOLD PROTRUSION/END FLASH
MOLD PROTRUSION/END FLASH SHALL NOT EXCEED 0.006 in (0.152 mm) PER SIDE
3. DIMENSIONS IN INCHES MIN.
MAX.

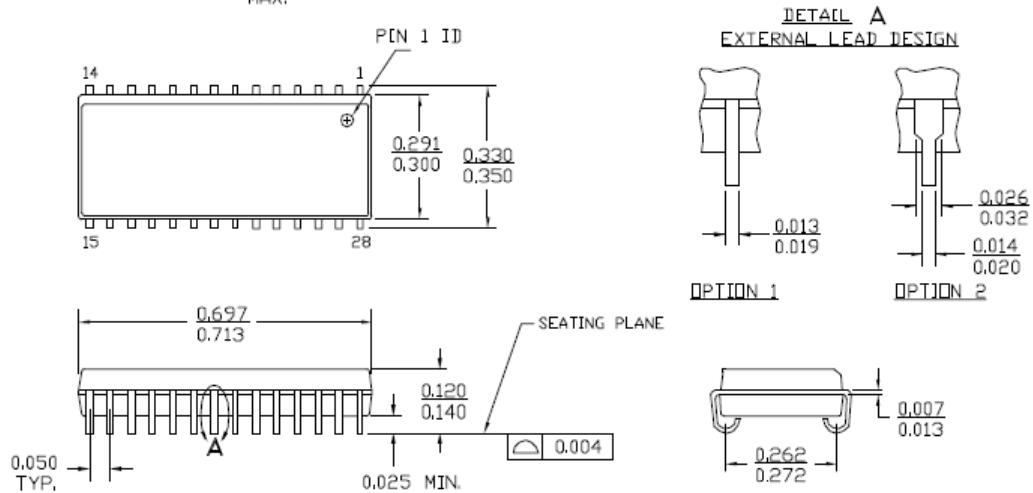

51-85031-°C

Document History Page

Document Title: CY7C419, CY7C421, CY7C425, CY7C429, CY7C433, 256/512/1K/2K/4Kx9 Asynchronous FIFO Document Number: 38-06001				
Rev.	ECN No.	Orig. of Change	Submission Date	Description of Change
**	106462	SZV	07/11/01	Change from Spec Number: 38-00079 to 38-06001
*A	122332	RBI	12/30/02	Added power up requirements to maximum ratings information.
*B	383597	PCX	See ECN	Added Pb-Free Logo Added to Part-Ordering Information: CY7C419-10JXC, CY7C419-15JXC, CY7C419-15VXC, CY7C421-10JXC, CY7C421-15AXC, CY7C421-20JXC, CY7C421-20VXC, CY7C425-10AXC, CY7C425-10JXC, CY7C425-15JXC, CY7C425-20JXC, CY7C425-20VXC, CY7C429-10AXC, CY7C429-15JXC, CY7C429-20JXC, CY7C433-10AXC, CY7C433-10JXC, CY7C433-15JXC, CY7C433-20AXC, CY7C433-20JXC
*C	2623658	VKN/PYRS	12/17/08	Added CY7C421-20JXI Removed CY7C419/25/29/33 from the ordering information table Removed 26-Lead CerDIP, 32-Lead RLCC, 28-Lead molded DIP packages from the data sheet Removed Military Information

Sales, Solutions and Legal Information

Worldwide Sales and Design Support

Cypress maintains a worldwide network of offices, solution centers, manufacturer's representatives, and distributors. To find the office closest to you, visit us at cypress.com/sales.

Products

PSoC	psoc.cypress.com
Clocks & Buffers	clocks.cypress.com
Wireless	wireless.cypress.com
Memories	memory.cypress.com
Image Sensors	image.cypress.com

PSoC Solutions

General	psoc.cypress.com/solutions
Low Power/Low Voltage	psoc.cypress.com/low-power
Precision Analog	psoc.cypress.com/precision-analog
LCD Drive	psoc.cypress.com/lcd-drive
CAN 2.0b	psoc.cypress.com/can
USB	psoc.cypress.com/usb

© Cypress Semiconductor Corporation, 2005-2008. The information contained herein is subject to change without notice. Cypress Semiconductor Corporation assumes no responsibility for the use of any circuitry other than circuitry embodied in a Cypress product. Nor does it convey or imply any license under patent or other rights. Cypress products are not warranted nor intended to be used for medical, life support, life saving, critical control or safety applications, unless pursuant to an express written agreement with Cypress. Furthermore, Cypress does not authorize its products for use as critical components in life-support systems where a malfunction or failure may reasonably be expected to result in significant injury to the user. The inclusion of Cypress products in life-support systems application implies that the manufacturer assumes all risk of such use and in doing so indemnifies Cypress against all charges.

Any Source Code (software and/or firmware) is owned by Cypress Semiconductor Corporation (Cypress) and is protected by and subject to worldwide patent protection (United States and foreign), United States copyright laws and international treaty provisions. Cypress hereby grants to licensee a personal, non-exclusive, non-transferable license to copy, use, modify, create derivative works of, and compile the Cypress Source Code and derivative works for the sole purpose of creating custom software and or firmware in support of licensee product to be used only in conjunction with a Cypress integrated circuit as specified in the applicable agreement. Any reproduction, modification, translation, compilation, or representation of this Source Code except as specified above is prohibited without the express written permission of Cypress.

Disclaimer: CYPRESS MAKES NO WARRANTY OF ANY KIND, EXPRESS OR IMPLIED, WITH REGARD TO THIS MATERIAL, INCLUDING, BUT NOT LIMITED TO, THE IMPLIED WARRANTIES OF MERCHANTABILITY AND FITNESS FOR A PARTICULAR PURPOSE. Cypress reserves the right to make changes without further notice to the materials described herein. Cypress does not assume any liability arising out of the application or use of any product or circuit described herein. Cypress does not authorize its products for use as critical components in life-support systems where a malfunction or failure may reasonably be expected to result in significant injury to the user. The inclusion of Cypress' product in a life-support systems application implies that the manufacturer assumes all risk of such use and in doing so indemnifies Cypress against all charges.

Use may be limited by and subject to the applicable Cypress software license agreement.