

THIS DRAWING IS UNPUBLISHED. RELEASED FOR PUBLICATION 1825031, 1825031
 © COPYRIGHT 1825031y - ALL RIGHTS RESERVED.

LOC		DIST		REVISIONS			
P	LTR	DESCRIPTION		DATE	DWN	APVD	
AD	00	C2	REVISED PER ECO-12-002677		13FEB12	KH	PO

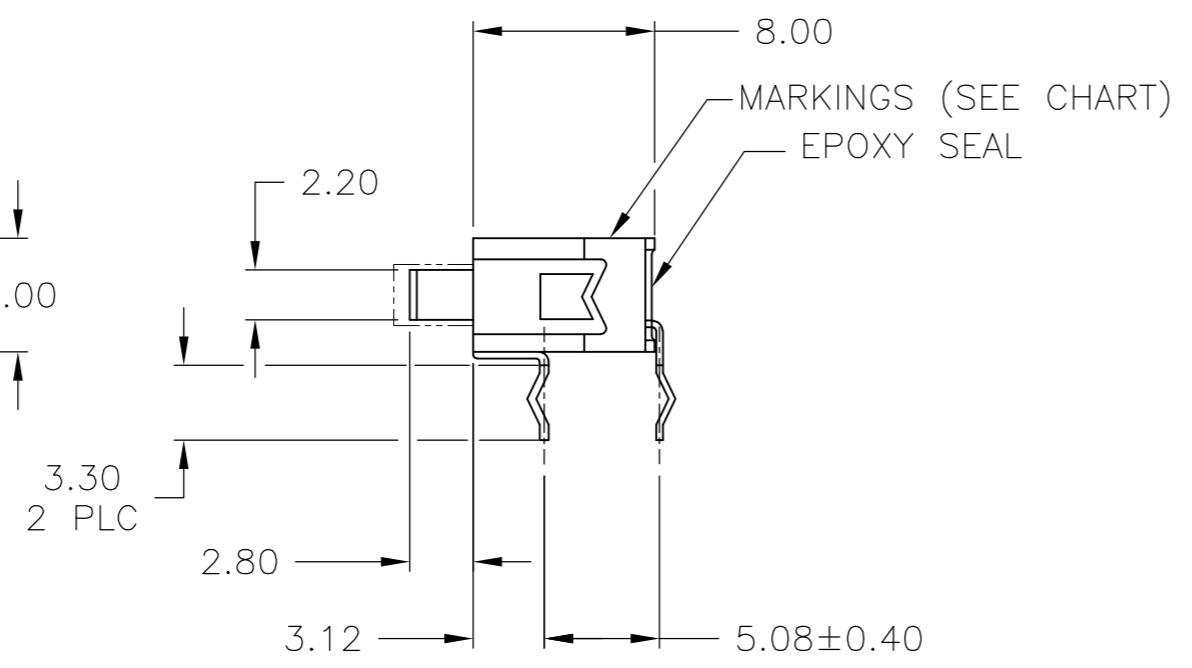

SINGLE POLE

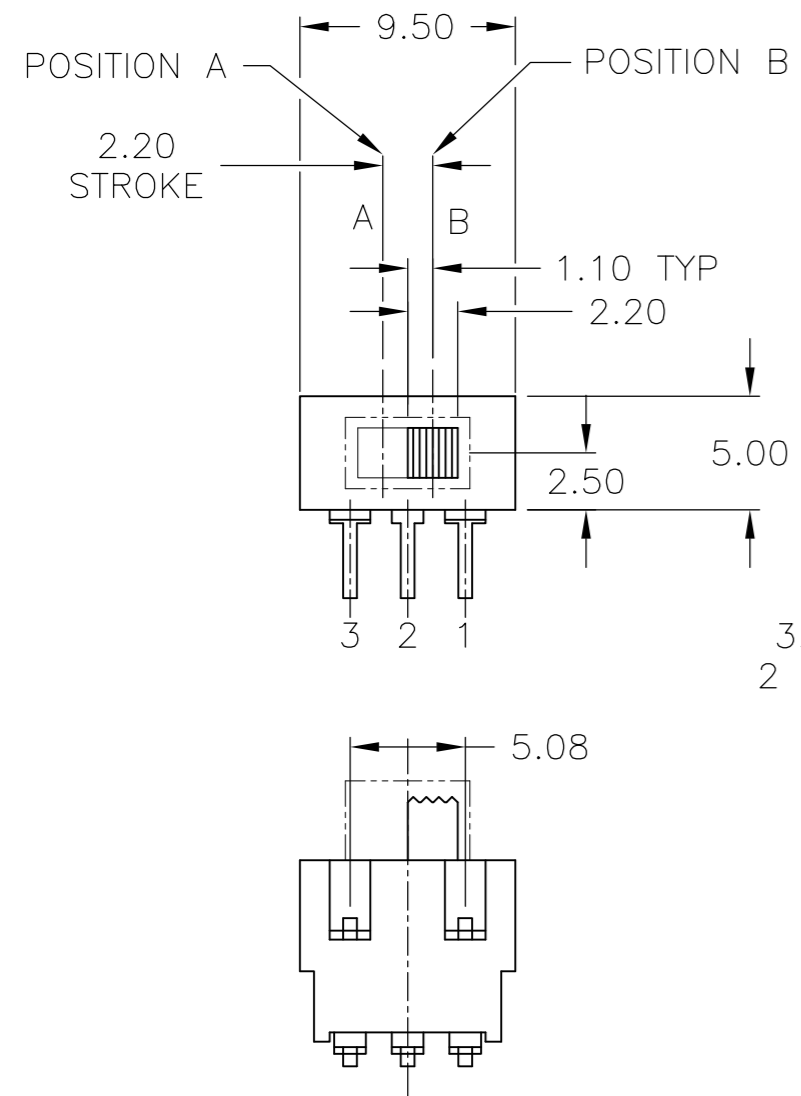
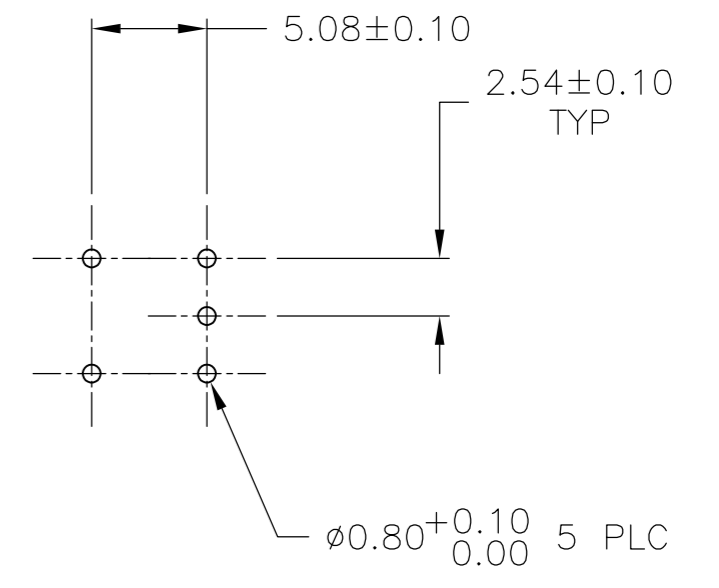
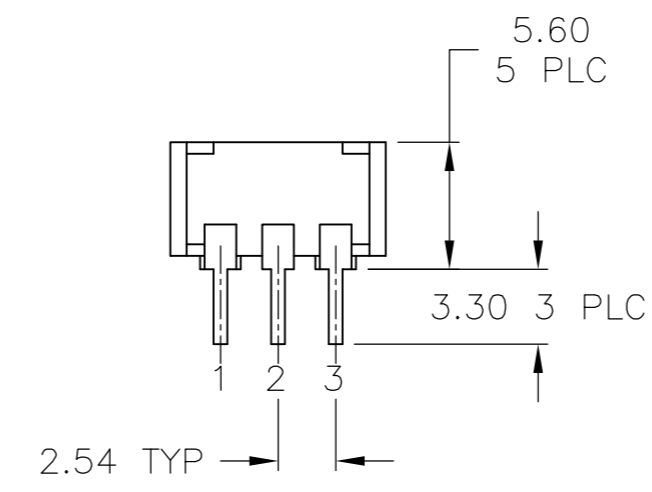

RECOMENDED P.C. HOLE LAYOUT SINGLE POLE

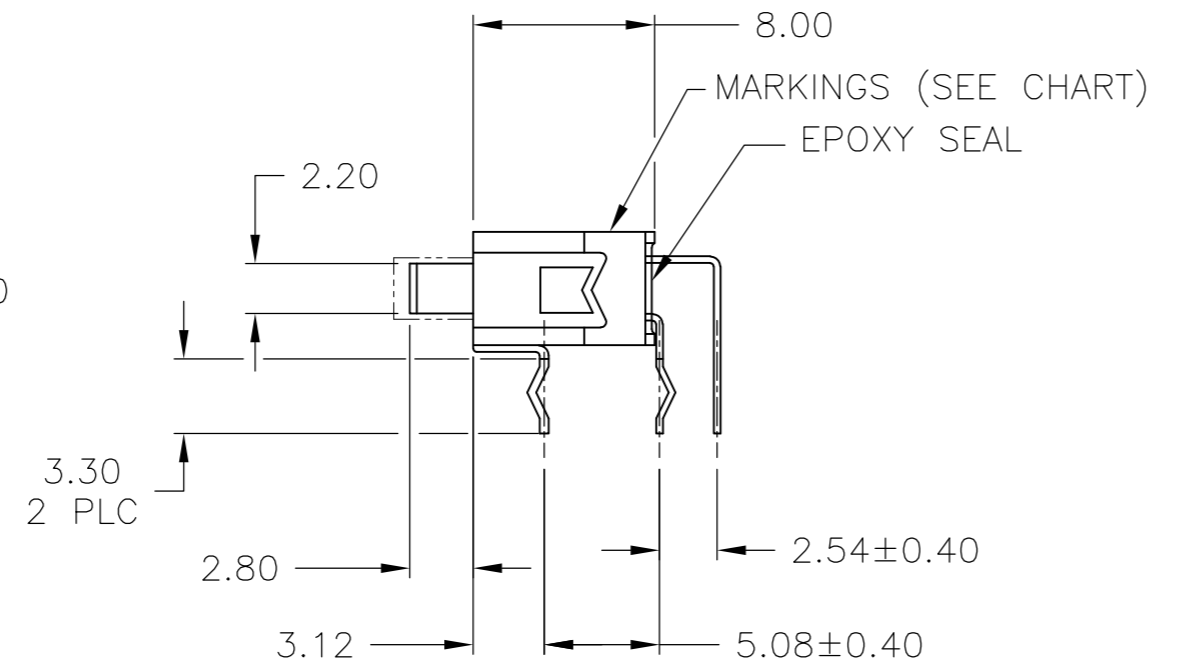
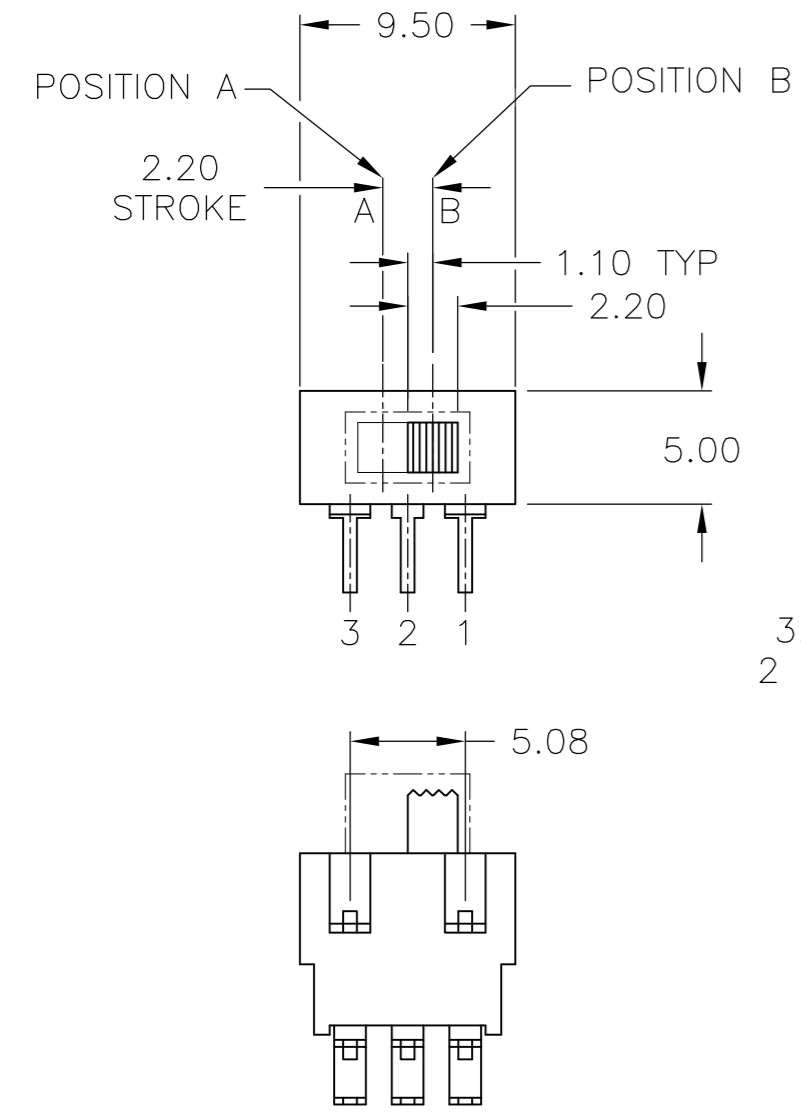

DOUBLE POLE

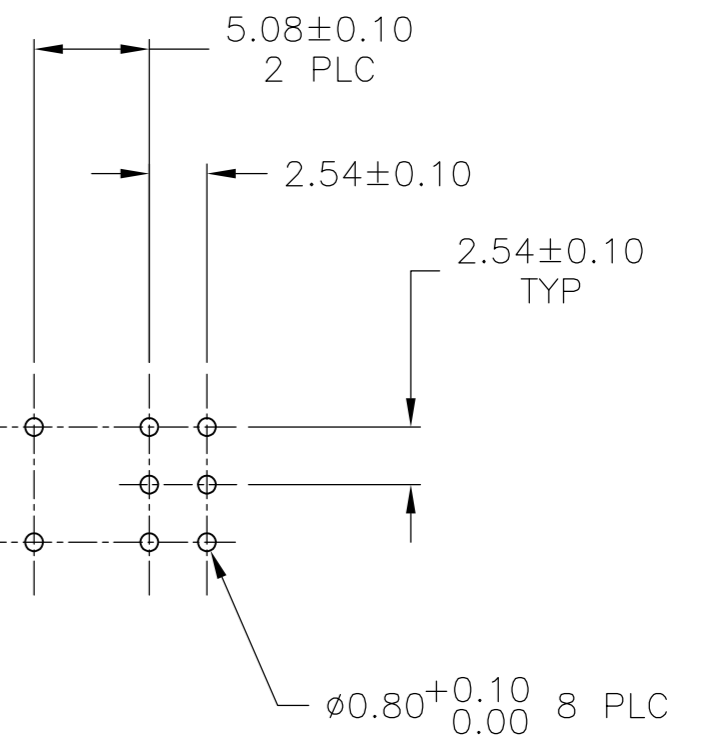
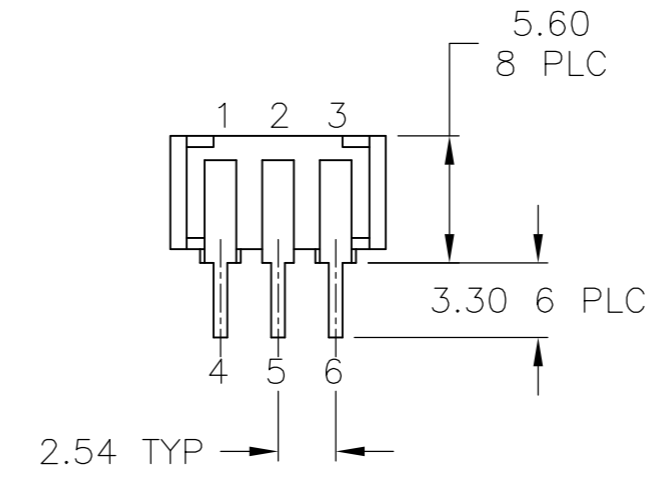

RECOMENDED P.C. HOLE LAYOUT DOUBLE POLE

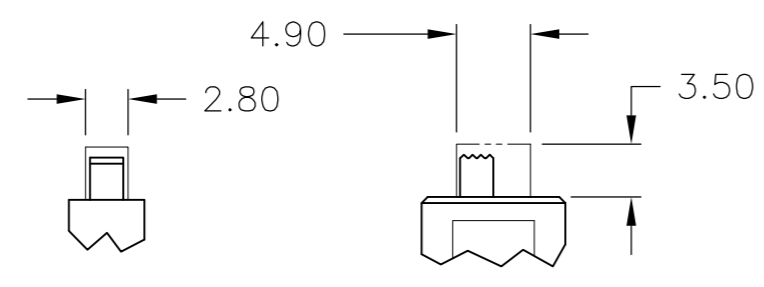



ACTUATOR BOOT DIMENSIONS SCALE 2:1

THIS DRAWING IS A CONTROLLED DOCUMENT.		DWN B.S.VISWESWARA 02MAR05	TE TE Connectivity	
DIMENSIONS: mm		CHK M.S.SARVER		
TOLERANCES UNLESS OTHERWISE SPECIFIED:		APVD -	NAME	
0 PLC ± -	1 PLC ± -	PRODUCT SPEC -	SWITCH, SLIDE, RIGHT ANGLE, SE(**)GRA	
2 PLC ± 0.25	3 PLC ± -	APPLICATION SPEC -	SIZE A2	CAGE CODE -
4 PLC ± -	ANGLES ± 0°30'	WEIGHT -	DRAWING NO C=1825031	RESTRICTED TO -
MATERIAL -	FINISH -	CUSTOMER DRAWING	SCALE 3:1	SHEET 1 OF 2
			REV C2	

THIS DRAWING IS UNPUBLISHED. RELEASED FOR PUBLICATION 1825031, 1825031
 © COPYRIGHT 1825031y - ALL RIGHTS RESERVED.



LOC		DIST		REVISIONS			
P	LTR	DESCRIPTION	DATE	DWN	APVD		
-	-	SEE SHEET 1	-	-	-		

- OPERATING TEMPERATURE: -20°C TO 80°C.
- STORAGE TEMPERATURE: -40°C TO 80°C.
- CONTACT TIMING: NON-SHORTING.
- CONTACT RATING: 0.4VA @ 20VDC.
- CONTACT RATING MAXIMUM: 50mA 48V AC/DC.
- CONTACT RATING MINIMUM: 1µA 20mV AC/DC.
-  CONTACT PLATING: GOLD OVER SILVER.
-  FIXED CONTACT/TERMINAL: GOLD OVER NICKEL.
-  FRAME PLATING: TIN OVER NICKEL.
- INITIAL CONTACT RESISTANCE: LESS THAN 50 MILLIOHMS PER EIA 364-23B.
- FINAL CONTACT RESISTANCE: 100 MILLIOHMS MAX PER EIA 364-23B.
- INSULATION RESISTANCE: 500 MEGOHMS MIN AT 250VDC PER EIA 364-21C.
- DIELECTRIC STRENGTH: 500VAC BETWEEN TERMINALS AND GROUND PER EIA 364-20B, CONDITION 1.
- VIBRATION PER EIA 364-28D, CONDITION VII, LEVEL E.
- MECHANICAL SHOCK PER EIA 364-27B, CONDITION A.

16. LIFE EXPECTANCY: ON-OFF ELECTRICAL SWITCHING OPERATIONS PER EIA 364-9C 10 CYCLES PER MINUTE AT THE FOLLOWING RATED LOAD.

TYPE	MAXIMUM CONTACT RATING	0.4 VA	MINIMUM CONTACT RATING
D.E	10000 (OPERATIONS)	30000 (OPERATIONS)	30000 (OPERATIONS)

- ACTUATION FORCE: 70-500g PER EIA 364-13B.
- THERMAL SHOCK PER EIA 364-32C, -25°C TO 85°C.
- HUMIDITY-TEMPERATURE CYCLING PER EIA 364-31B, METHOD III.
- TEMPERATURE LIFE PER EIA 364-17B, METHOD B, TEMPERATURE TEST CONDITION 3, TIME CONDITION B.
- RESISTANCE TO SOLDER HEAT PER 109-202,CON B.
- SOLDERABILITY PER EIA 364-52, CLASS 2, CATEGORY 1.
- PROCESS SEALED.
- ALL MATERIALS AND FINISHES SHALL COMPLY WITH EU DIRECTIVE 2000/95/EC OF 27 JAN2003 (ROHS)

COLOR- WHITE	PET FILM UL94-HB	SLIDE PLATE
COLOR- BLACK	PA46 UL94V-0 30% GLASS FILLED	TERMINAL BOARD
-	STAINLESS STEEL	COIL SPRING
COLOR- WHITE	PA46 UL94V-0 30% GLASS FILLED	PLUNGER
-	SILICON RUBBER	ACTUATOR BOOT
-	EPOXY	TERMINAL SEAL
	PHOSPHOR BRONZE	MOVABLE CONTACT
	PHOSPHOR BRONZE	FIXED CONTACT /TERMINAL
COLOR- YELLOW	PA46 UL94V-0 30% GLASS FILLED	ACTUATOR
	BRASS	FRAME
COLOR- GRAY	PA46 UL94V-0 30% GLASS FILLED	CASE
FINISH	MATERIAL	PART DESCRIPTION

ON 2-3 5-6	OFF	ON 2-1 5-4	ALCO	SE2EGRA04	1825031-4
ON 2-3 5-6	NONE	ON 2-1 5-4	ALCO	SE2DGRA04	1825031-3
ON 2-3	OFF	ON 2-1	ALCO	SE1EGRA04	1825031-2
ON 2-3	NONE	ON 2-1	ALCO	SE1DGRA04	1825031-1
			MARKINGS	ALCOSWITCH PART NUMBER	TE PART NUMBER
POSITION A		POSITION B			
CIRCUIT ARRANGEMENT					
CIRCUIT CHARACTERISTICS					

THIS DRAWING IS A CONTROLLED DOCUMENT.		DWN B.S.VISWESWARA 02MAR05	 TE Connectivity	
DIMENSIONS: mm		CHK M.S.SARVER		
TOLERANCES UNLESS OTHERWISE SPECIFIED:		APVD -	NAME SWITCH, SLIDE, RIGHT ANGLE, SE(**)GRA	
0 PLC ± -		PRODUCT SPEC -	SIZE A2	
1 PLC ± -		APPLICATION SPEC -	CAGE CODE -	
2 PLC ± 0.25		WEIGHT -	DRAWING NO C=1825031	
3 PLC ± -		CUSTOMER DRAWING	RESTRICTED TO -	
4 PLC ± -		SCALE 1:1	SHEET 2 OF 2	
ANGLES ± 0°30'		REV C2		