

PHOTONIC DETECTORS INC.

Silicon Carbide (SiC), Ultra Violet (U.V.) Photodiode Type PDU-S102

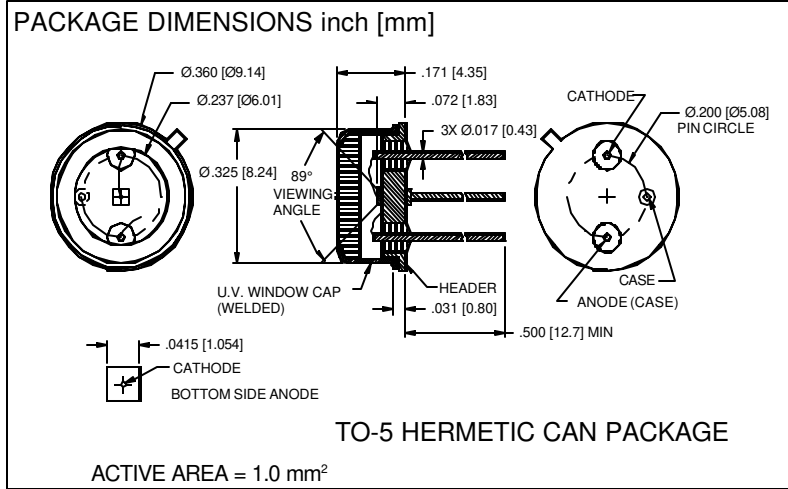

FEATURES

- 0.14 A/W @ 280 nm
- High shunt resistance
- 280 nm peak response
- Short wavelength resp.

DESCRIPTION

The **PDU-S102** is a SiC, planar passivated U.V. photodiode. Spectral range from 200 nm to 400 nm with a 1.0 mm² active area. Packaged in a hermetic TO-5 with a U.V. transmitting window cap.

APPLICATIONS

- Flame detectors
- U.V. sensors
- U.V. monitors
- U.V. instrumentation

ABSOLUTE MAXIMUM RATING (TA=25°C unless otherwise noted)

SYMBOL	PARAMETER	MIN	MAX	UNITS
V _{BR}	Reverse Voltage		20	V
T _{STG}	Storage Temperature	-55	+175	°C
T _O	Operating Temperature Range	-40	+125	°C
T _S	Soldering Temperature*		+240	°C
I _L	Light Current		0.5	mA

*1/16 inch from case for 3 secs max

SPECTRAL RESPONSE

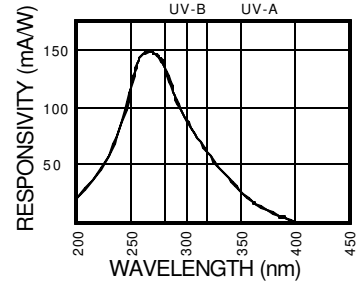

ELECTRO-OPTICAL CHARACTERISTICS (TA=25°C unless otherwise noted)

SYMBOL	CHARACTERISTIC	TEST CONDITIONS	MIN	TYP	MAX	UNITS
I _{SC}	Short Circuit Current	H = 1 SUN, 360 nm		1.0		μA
I _D	Dark Current	H = 0, V _R = 1 V		10	50	pA
R _{SH}	Shunt Resistance	H = 0, V _R = 10 mV	100	200		MΩ
TC _{R_{SH}}	RSH Temp. Coefficient	H = 0, V _R = 10 mV		-8		% / °C
C _J	Junction Capacitance	H = 0, V _R = 0 V**		200	250	pF
λ _{range}	Spectral Application Range	Spot Scan	200		400	nm
λ _p	Spectral Response - Peak	Spot Scan		280		nm
V _{BR}	Breakdown Voltage	I = 10 μA	10	30		V
NEP	Noise Equivalent Power	V _R = 10 V @ Peak		1.0x10 ⁻¹³		W/√Hz
tr	Response Time	RL = 1 KΩ V _R = 10 V		50	100	nS

Information in this technical data sheet is believed to be correct and reliable. However, no responsibility is assumed for possible inaccuracies or omission. Specifications are subject to change without notice. ** f = 1MHz

[FORM NO. 100-PDU-S102 REV N/C]