



Microsemi

Description

The LX7176 is a 3A step-down regulator with integrated MOSFETs placed in a space saving QFN12 2mm x 2mm package for today's mobile devices. It uses an ultra fast, constant frequency hysteretic control method and a high switching frequency to minimize external filter components while maintaining excellent regulation. The LX7176 has a fixed 0.6V reference, Power Good, and Enable pins. The LX7176 operates from 3.0V to 5.5V rails.

Cycle-by-cycle current limiting protects against over-current conditions. The LX7176 operates in hiccup mode to further enhance the robustness of the converter for heavy over-load or short-circuit faults and it automatically recovers once the fault clears.

Thermal protection shuts down the regulator under over-temperature conditions. Over voltage conditions will immediately shut off the output to protect against permanent damage.

Features

- ◆ 0-3A Step-down Regulator
- ◆ Operational Input Supply Voltage Range: 3.0V-5.5V (short durations to 6.5V)
- ◆ Integrated PMOS and NMOS
- ◆ Hysteretic Control Offers Best Transient Response
- ◆ PWM Switching at a Constant 1.65MHz
- ◆ Input Under-voltage and Over-voltage Protection
- ◆ Enable and Power Good Function
- ◆ Internal Soft-start
- ◆ Cycle-by-Cycle Over Current Protection
- ◆ Hiccup Mode Protects Against Short Circuit Faults
- ◆ RoHS Compliant & Halogen Free

Applications

- High Performance HDD
- LCD TV
- Notebook/Netbook
- Server and Workstations
- Video Cards
- PoE Powered Devices Smart Phone

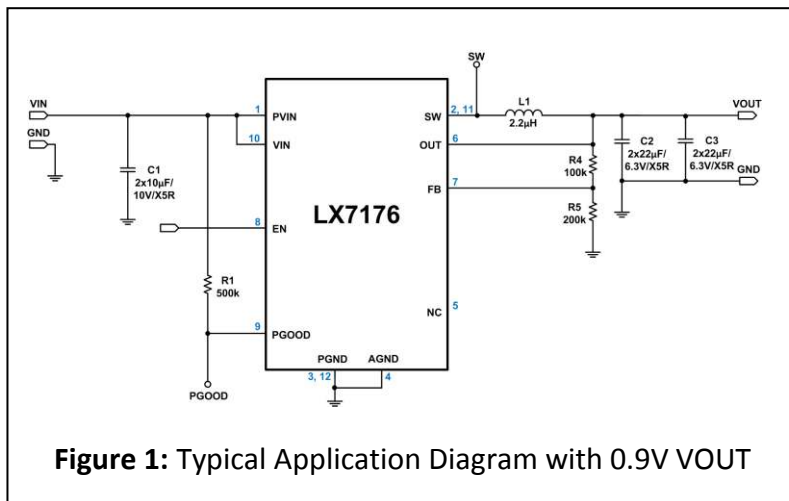

Figure 1: Typical Application Diagram with 0.9V VOUT



Microsemi

Other Typical Application Diagram

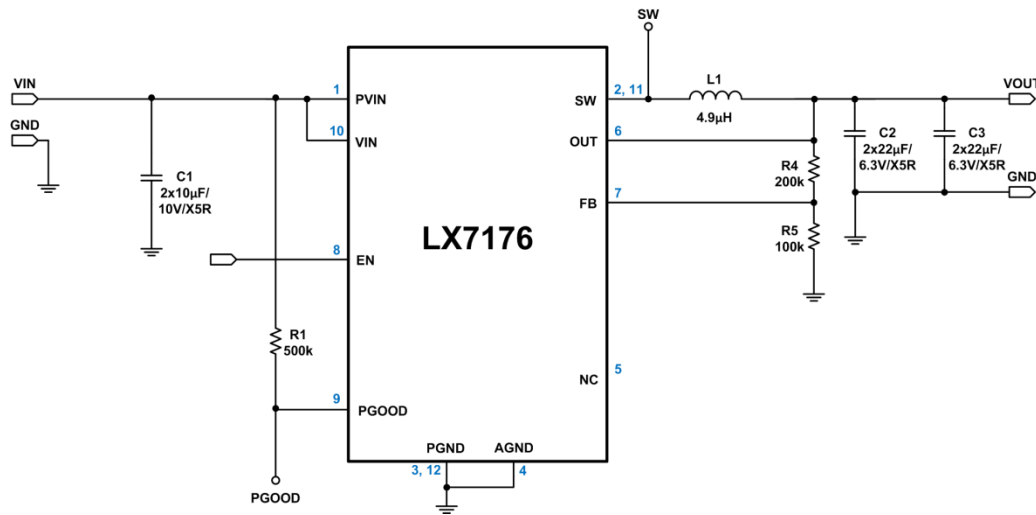
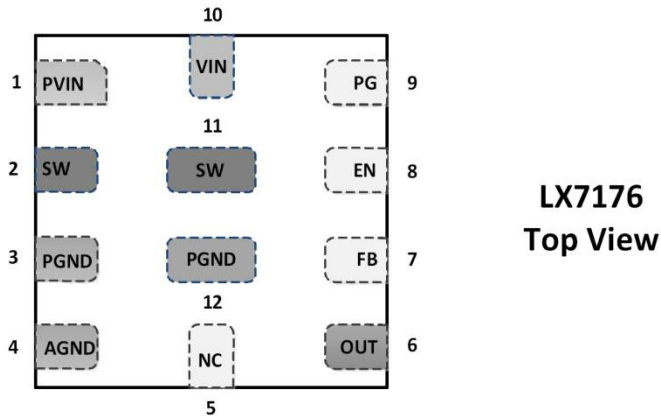

Figure 2. Typical Application with 1.8V VOUT

Pin Configuration and Pinout



•7176
YWWL

- Pin 1 Indicator, YWWL = Year/Week/Lot Code
- RoHS / Pb-free Matte Tin Pin Finish

Figure 3: Pinout

Microsemi®

Ordering Information

Ambient Temperature	Type	Package	Part Number	Packaging Type
0°C to 85°C	RoHS compliant, Pb-free	QFN 2x2mm 12L	LX7176CLQ	Bulk
			LX7176CLQ-TR	Tape and Reel

Thermal Properties

Thermal Resistance(θ_{JA})	Typ	Units
QFN 2x2mm 12L	30	°C/W

Note: The θ_{jx} numbers assume no forced airflow. Junction Temperature is calculated using $T_J = T_A + (P_D \times \theta_{JA})$. In particular, θ_{JA} is a function of the PCB construction. The stated number above is for a four-layer board in accordance with JESD-51 (JEDEC).

Pin Description

Pin Number	Pin Designator	Description
1	PVIN	Supply Voltage – A capacitor is needed to prevent voltage spikes from damaging the device. The capacitor return should be connected directly to the PGND pin.
2, 11	SW	Switch Output – This pin switches between PVIN and GND.
3, 12	PGND	Power Ground – Power return.
4	AGND	Analog Ground – Quiet ground for control circuits.
5	NC	Leave pin unconnected.
6	OUT	Output Voltage Sense Pin – This pin monitors the output voltage.
7	FB	Feedback – This pin is connected to an external resistor divider to program the system output voltage.
8	EN	Enable – The device is enabled when this pin is held high.
9	PG	Power Good – Open Drain output that is pulled low when the FB is outside the “good” range, during soft start, or during a fault condition.
10	VIN	Internal control circuit supply voltage. Internal connection to PVIN.



Microsemi

Block Diagram

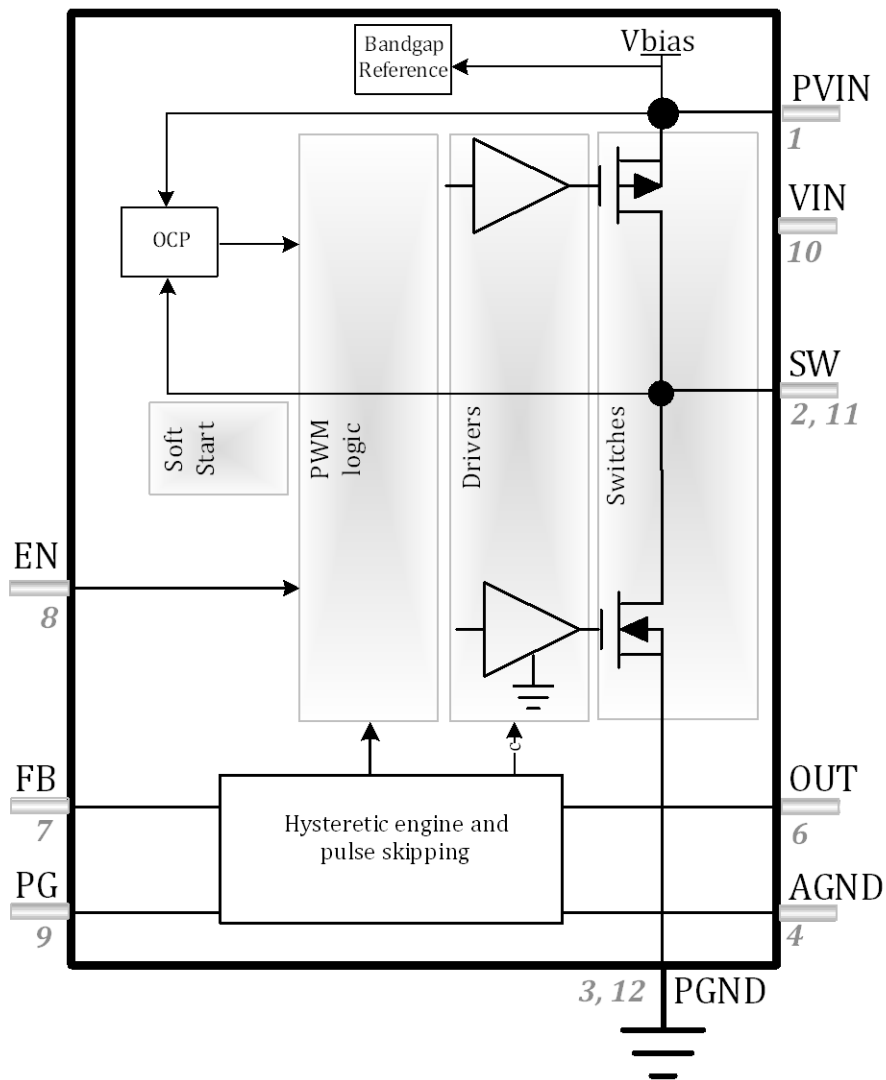

Figure 4: Block Diagram

**Microsemi**

Absolute Maximum Ratings

Performance is not necessarily guaranteed over this entire range. These are maximum stress ratings only. Exceeding these ratings, even momentarily, can cause immediate damage, or negatively impact long-term operating reliability.

Parameter	Min	Max	Units
VIN, PVIN, EN, PG, OUT, FB to GND	-0.3	7	V
SW to GND	-0.3	7	V
SW to GND (Shorter than 50ns)	-2	7	V
Maximum Junction Temperature		150	°C
Storage Temperature	-65	150	°C
Peak Lead Soldering Temperature (40s, reflow)		260	°C

Operating Ratings

Performance is generally guaranteed over this range as further detailed below under Electrical Characteristics.

Parameter	Min	Max	Units
Input Voltage	3.0	5.5	V
Output Voltage	0.6	3.3	V
Output Current	0	3	A
Ambient Temperature	0	85	°C

Note: Corresponding Max Junction Temperature is 125°C

Microsemi®

Electrical Characteristics

Unless otherwise specified, the following specifications apply over the operating ambient temperature of $0^{\circ}\text{C} \leq T_A \leq 85^{\circ}\text{C}$ except where otherwise noted with the following test conditions: $P_{VIN} = 5\text{V}$. $T_J = 25^{\circ}\text{C}$, unless otherwise specified.

Symbol	Parameter	Conditions	Min	Typ	Max	Units
VIN						
I_Q	No Load Input Current	$I_{LOAD} = 0$, PWM, $V_{FB}=0.75\text{V}$		600		μA
I_{SLEEP}	Input Current at Shutdown	EN = low		0.1	3	μA
UVLO	Under Voltage Rising Threshold	VIN rising			2.8	V
UVLO_{HYST}	UVLO Hysteresis	PVIN falling		0.2		V
OVP_R	Over Voltage Rising Threshold	PVIN rising. Will also trigger on $DV/DT > 1\text{V}/\mu\text{s}$		6.21		V
OVP_F	Over Voltage Falling Threshold	PVIN falling	5.5	5.85		V
VREF						
V_{REF}	Reference Voltage		0.594	0.6	0.606	V
T_{SS}	V _{REF} Slew Rate			2		mV/ μs
T_{HICCUP}	Hiccup Time	FB = 0.2V, does not include soft start time		1.2		ms
FB						
	Line Regulation ¹	VIN from 4.0V to 5.5V, $I_{LOAD} = 1.0\text{A}$		0.1		%/V
	Load Regulation ¹	$I_{LOAD} = 0.5\text{A}$ to 2A		-0.1		%/A
	FB Input Current				1	μA
FBUVLO	FB Under Voltage Threshold	VOUT below this threshold will initiate a hiccup sequence.		80%		V _{REF}
VOUT	Output Discharge Resistance	EN = low	80	200	1400	Ω



Microsemi

Symbol	Parameter	Conditions	Min	Typ	Max	Units
SW						
R_{DSON_H}	High Side On Resistance			35		mΩ
R_{DSON_L}	Low Side On Resistance			21		mΩ
	Rated Output Current			3		A
OCP	Current Limit	WRT rated current	140	170	200	%
T_{SH}	Thermal Shutdown Threshold ¹			150		°C
T_H	Thermal Shutdown Hysteresis ¹			20		°C
f	PWM Switching Frequency		1.2	1.65	2	MHz
T_{OCP}	OCP off time in CCM	$I_{OUT} = 5A$		360		ns
EN						
V_{IH}	Input High		1.1			V
V_{IL}	Input Low				0.4	V
V_H	Hysteresis			0.1		V
I_{II}	Input Current			0.01	1	μA
PG						
V_{PG90}	PGOOD VOUT Lower Threshold	VOUT rising, percentage of V_{REF}		90		%
V_{PG110}	PGOOD VOUT Upper Threshold	VOUT falling, percentage of V_{REF}		110		%
V_{PGHY}	Hysteresis	Percentage of V_{REF}		5		%
PG_{RDSON}	PGOOD Pull-down Resistance			100	300	Ω
	PGOOD Leakage Current			0	1	μA

¹ These parameters are not tested, but guaranteed by design and characterization.



Microsemi

Typical Performance Curves (Efficiency)

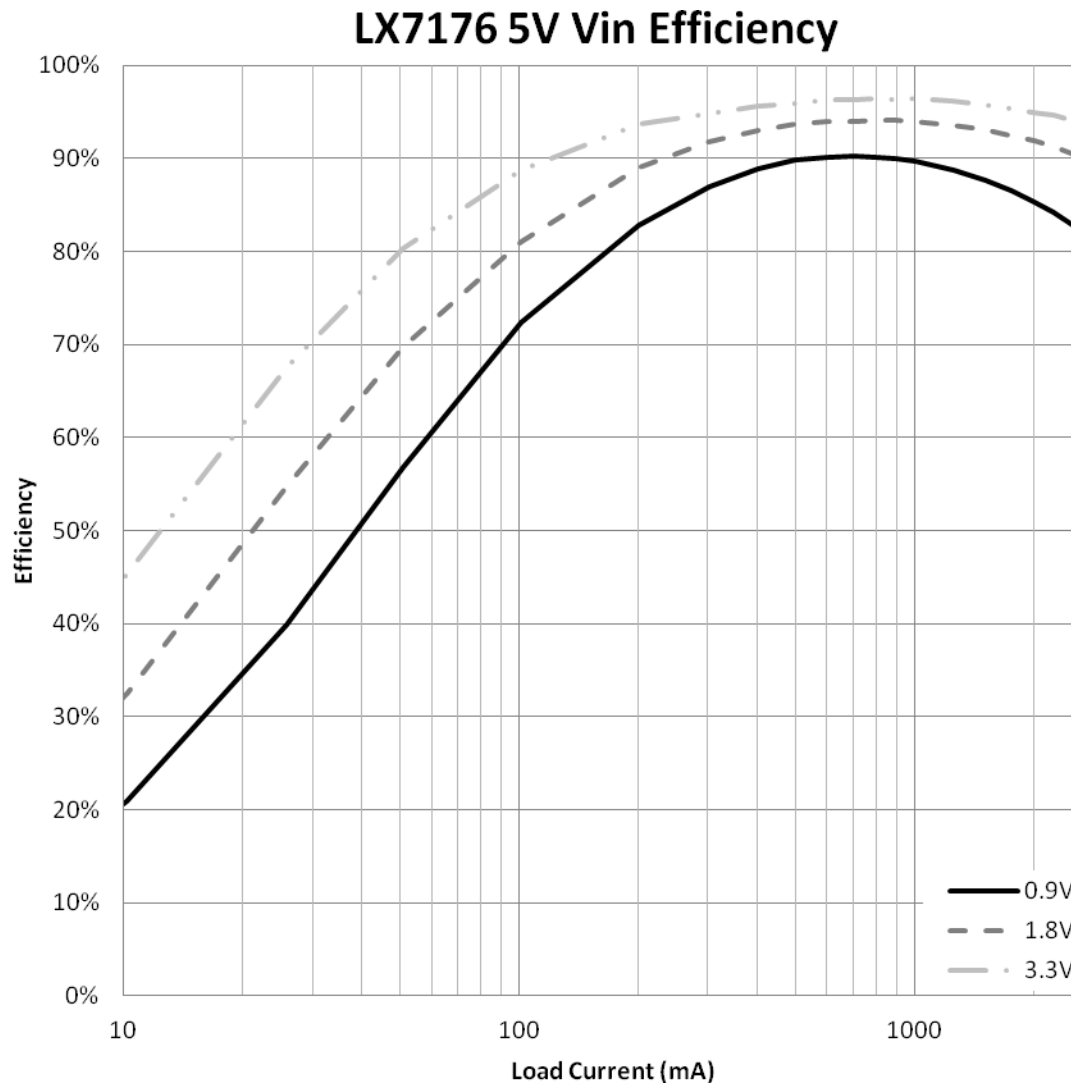
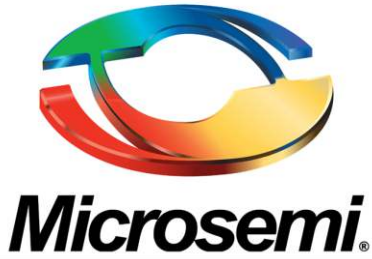
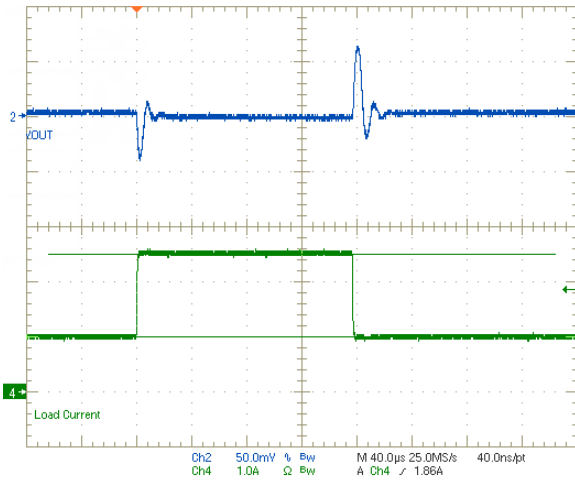

Figure 5: LX7176 Efficiency with 0.9V, 1.8V and 3.3V Output Voltage



Step Response (Load Current = 1A to 2.5A, Cout = 4*22μF)



CH2: VOUT, CH4: Load Current
Figure 6. VOUT = 0.9V, L = 2.2μH

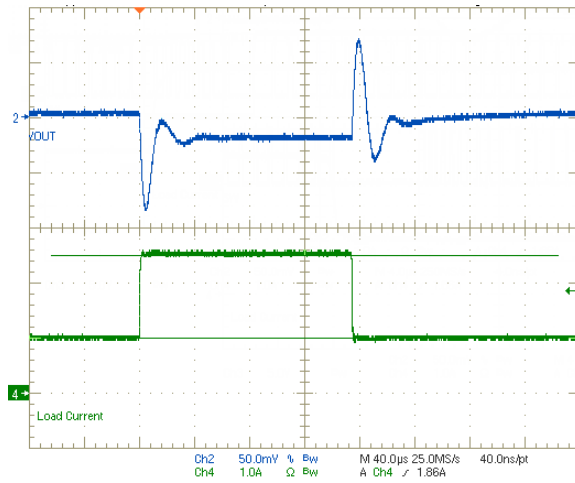

CH2: VOUT, CH4: Load Current
Figure 7. VOUT = 1.8V, L = 4.9μH

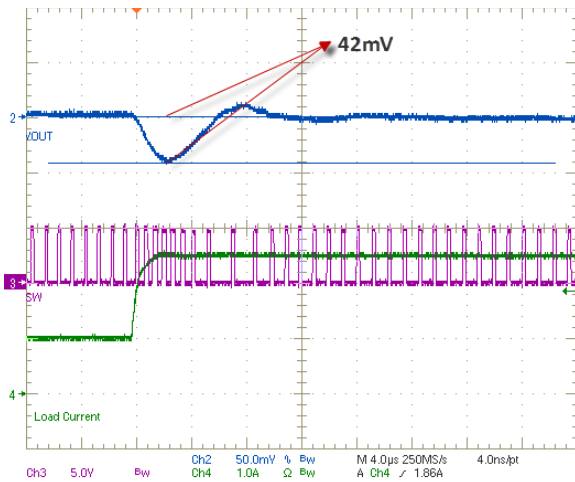

CH2: VOUT, CH3: SW, CH4: Load Current
Figure 8. VOUT = 0.9V, L = 2.2μH

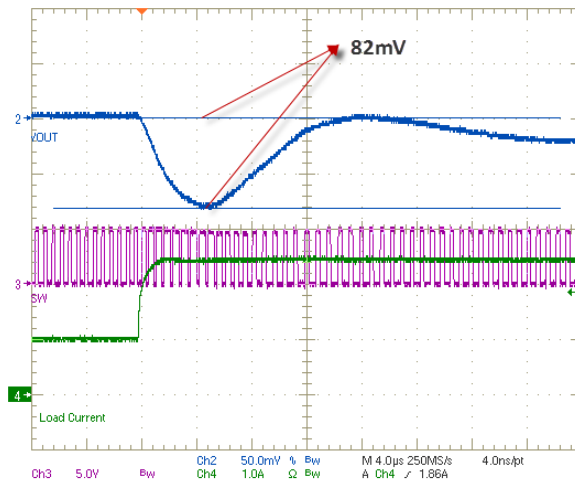

CH2: VOUT, CH3: SW, CH4: Load Current
Figure 9. VOUT = 1.8V, L = 4.9μH



Microsemi

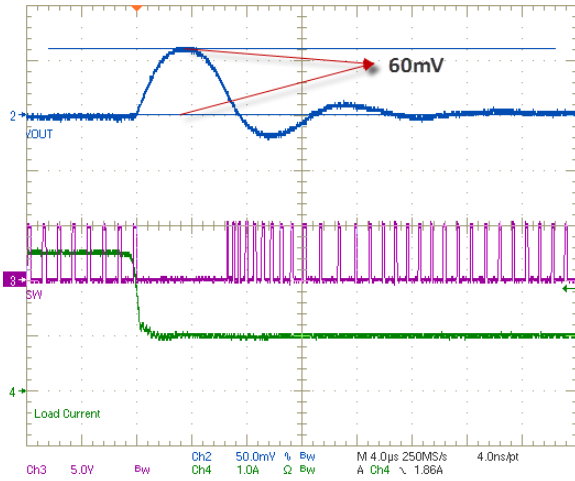

CH2: VOUT, CH3: SW, CH4: Load Current
Figure 10. VOUT = 0.9V, L = 2.2µH

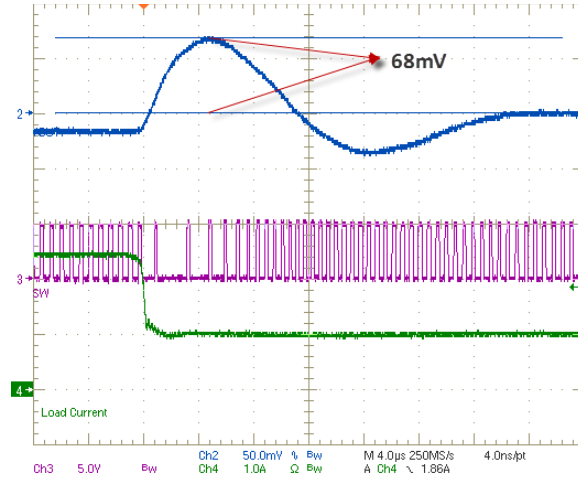

CH2: VOUT, CH3: SW, CH4: Load Current
Figure 11. VOUT = 1.8V, L = 4.9µH

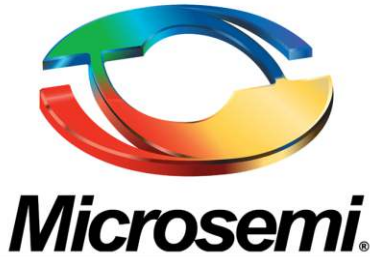

Theory of Operation

Basic Operation

The LX7176 compares the FB voltage to an internal reference, V_{REF} . When FB is lower than V_{REF} , the upper switch turns on and the lower switch turns off. When FB is higher than V_{REF} , the upper switch turns off and the lower switch turns on, V_{REF} is fixed at 0.6V. An internal ramp keeps FB constant over a wide range of output capacitor values and parasitic components (i.e. ESR, ESL). In addition, a frequency control loop keeps the switching frequency constant during continuous conduction mode (CCM).

Startup

The LX7176 is enabled when EN is high and PVIN rises above the UVLO threshold. At start up, V_{REF} ramps up from 0V to 0.6V. While V_{REF} ramps; PGOOD (PG Pin) is held low. At the end of the ramp time, PG is allowed to go high after FB has reached the PGOOD rising threshold.

Over Current Protection

The LX7176 protects against all types of short circuit conditions. Cycle by cycle over current protection turns off the upper switch when the current exceeds the OCP threshold. When this occurs, the upper switch is kept off for about 360ns before being allowed to turn on again. After startup, if FB drops below the FB under voltage threshold, a hiccup sequence will be initiated where both output switches are shut off for 1.2ms before initiating another soft start. This protects against a crowbar short circuit. The FB under voltage detection is not active during startup.

Application Information

Output Components Selection

VOUT	Inductor (L1)	Upper Feedback Resistor (R4)	Lower Feedback Resistor (R5)	Output Capacitor (C2 & C3)
0.9V	2.2 μ H	100k Ω	200k Ω	4x22 μ F
1.8V	4.9 μ H	200k Ω	100k Ω	4x22 μ F
3.3V	1.0 μ H	453k Ω	100k Ω	4x22 μ F

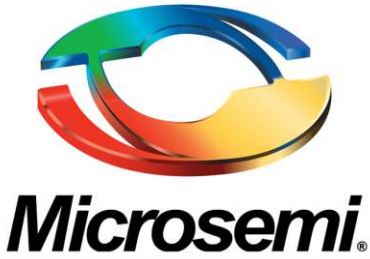

Package Dimensions

QFN 2x2mm 12L Package

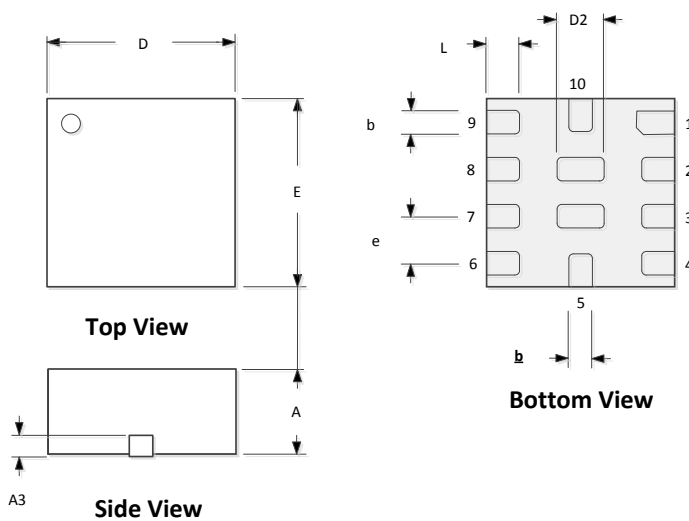

Dim	MILLIMETERS		INCHES	
	MIN	MAX	MIN	MAX
A	0.80	1.00	0.031	0.039
A3	0.20 REF		0.008 REF	
B	0.20	0.30	0.008	0.012
D	2.0 BSC		0.078 BSC	
D2	0.50		0.020	
E	2.0 BSC		0.078 BSC	
e	0.50 REF		0.020 REF	
L	0.30	0.45	0.012	0.018

Note:

1. Dimensions do not include mold flash or protrusions; these shall not exceed 0.155mm (.006") on any side. Lead dimension shall not include solder coverage.
2. Dimensions are in millimeters, inches for reference only.

PRODUCTION DATA – Information contained in this document is proprietary to Microsemi and is current as of publication date. This document may not be modified in any way without the express written consent of Microsemi. Product processing does not necessarily include testing of all parameters. Microsemi reserves the right to change the configuration and performance of the product and to discontinue product at any time.