

National Semiconductor is now part of
Texas Instruments.

Search <http://www.ti.com/> for the latest technical
information and details on our current products and services.

LMV116/LMV118

Low Voltage, 45MHz, Rail-to-Rail Output Operational Amplifiers with Shutdown Option

General Description

The LMV116 (single) rail-to-rail output voltage feedback amplifiers offer high speed (45MHz), and low voltage operation (2.7V) in addition to micro-power shutdown capability (LMV118).

Output voltage range extends to within 20mV of either supply rail, allowing wide dynamic range especially in low voltage applications. Even with low supply current of 600µA, output current capability is kept at a respectable ±20mA for driving heavier loads. Important device parameters such as BW, Slew Rate and output current are kept relatively independent of the operating supply voltage by a combination of process enhancements and design architecture.

For portable applications, the LMV118 provides shutdown capability while keeping the turn-off current to 15µA. Both turn-on and turn-off characteristics are well behaved with minimal output fluctuations during transitions. This allows the part to be used in power saving mode, as well as multiplexing applications. Miniature packages (SOT23-5 & SOT23-6) are further means to ease the adoption of these low power high speed devices in applications where board area is at a premium.

Features

($V_S = 2.7V$, $T_A = 25^\circ C$, $R_L = 1k\Omega$ to $V+/2$, $A_V = +1$. Typical values unless specified).

- -3dB BW 45MHz
- Supply voltage range 2.7V to 12V
- Slew rate 40V/µs
- Supply current 600µA
- Power down supply current 15µA
- Output short circuit current 32mA
- Linear output current ±20mA
- Input common mode voltage -0.3V to 1.7V
- Output voltage swing 20mV from rails
- Input voltage noise $40nV/\sqrt{Hz}$
- Input current noise $0.75pA/\sqrt{Hz}$

Applications

- High speed clock buffer/driver
- Active filters
- High speed portable devices
- Multiplexing applications (LMV118)
- Current sense amplifier
- High speed transducer amplifier

Typical Application

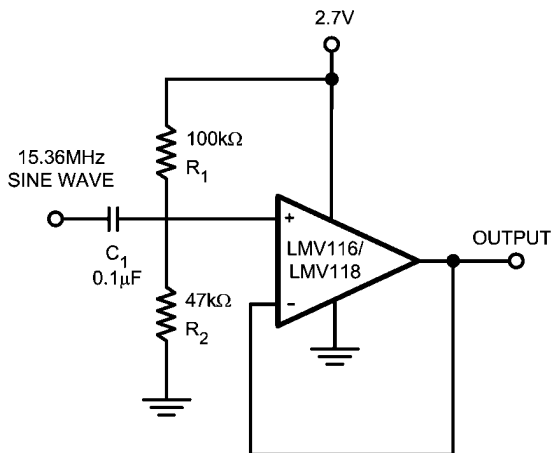

Non-Inverting Clock Buffer Amplifier

20080704

Absolute Maximum Ratings (Note 1)

If Military/Aerospace specified devices are required, please contact the National Semiconductor Sales Office/ Distributors for availability and specifications.

ESD Tolerance	
Human Body	2KV (Note 2)
Machine Model	200V (Note 9)
V_{IN} Differential	$\pm 2.5V$
Output Short Circuit Duration	(Note 3), (Note 11)
Supply Voltage ($V^+ - V^-$)	12.6V
Voltage at Input/Output pins	$V^+ + 0.8V, V^- - 0.8V$
Storage Temperature Range	$-65^\circ C$ to $+150^\circ C$

Junction Temperature (Note 4)	$+150^\circ C$
Soldering Information	
Infrared or Convection (20 sec)	$235^\circ C$
Wave Soldering Lead Temp. (10 sec)	$260^\circ C$

Operating Ratings (Note 1)

Supply Voltage ($V^+ - V^-$)	2.5V to 12V
Temperature Range (Note 4)	$-40^\circ C$ to $+85^\circ C$
Package Thermal Resistance (Note 4) (θ_{JA})	
SOT23-5	$265^\circ C/W$
SOT23-6	$265^\circ C/W$

2.7V Electrical Characteristics

Unless otherwise specified, all limits guaranteed for at $T_J = 25^\circ C$, $V^+ = 2.7V$, $V^- = 0V$, $V_{CM} = V_O = V^+/2$, and $R_F = 2k\Omega$, and $R_L = 1k\Omega$ to $V^+/2$. **Boldface** limits apply at the temperature extremes.

Symbol	Parameter	Conditions	Min (Note 6)	Typ (Note 5)	Max (Note 6)	Units
V_{OS}	Input Offset Voltage	$0V \leq V_{CM} \leq 1.7V$		± 1	± 5 ± 6	mV
TC V_{OS}	Input Offset Average Drift	(Note 12)		± 5		$\mu V/C$
I_B	Input Bias Current	(Note 7)	-2.0 -2.2	-0.40		μA
I_{OS}	Input Offset Current			1	500	nA
CMRR	Common Mode Rejection Ratio	V_{CM} Stepped from 0V to 1.55V	73	88		dB
PSRR	Power Supply Rejection Ratio	$V^+ = 2.7V$ to $3.7V$ or $V^- = 0V$ to $-1V$	72	85		dB
R_{IN}	Common Mode Input Resistance			3		$M\Omega$
C_{IN}	Common Mode Input Capacitance			2		pF
CMVR	Input Common-Mode Voltage Range	CMRR $\geq 50dB$	-0.3 -0.1		1.7	V
A_{VOL}	Large Signal Voltage Gain	$V_O = 0.35V$ to $2.35V$	73 70	87		dB
V_O	Output Swing High	$R_L = 1k\Omega$ to $V^+/2$	2.55	2.66		V
		$R_L = 10k\Omega$ to $V^+/2$		2.68		
	Output Swing Low	$R_L = 1k\Omega$ to $V^+/2$	150	40		mV
		$R_L = 10k\Omega$ to $V^+/2$		20		
I_{SC}	Output Short Circuit Current	Sourcing to V^- $V_{ID} = 200mV$ (Note 10)	25	35		mA
		Sinking to V^+ $V_{ID} = -200mV$ (Note 10)	25	32		
I_{OUT}	Output Current	$V_{OUT} = 0.5V$ from rails		± 20		mA
I_S	Supply Current	Normal Operation		600	900	μA
		Shut-down Mode (LMV118)		15	50	
SR	Slew Rate (Note 8)	$A_V = +1, V_O = 1V_{PP}$		40		$V/\mu s$
BW	$-3dB$ BW	$A_V = +1, V_{OUT} = 200mV_{PP}$		45		MHz
e_n	Input -Referred Voltage Noise	$f = 100kHz$		40		nV/\sqrt{Hz}
		$f = 1kHz$		60		
i_n	Input-Referred Current Noise	$f = 100kHz$		0.75		pA/\sqrt{Hz}
		$f = 1kHz$		1.20		
t_{on}	Turn-on Time (LMV118)			250		ns

Symbol	Parameter	Conditions	Min (Note 6)	Typ (Note 5)	Max (Note 6)	Units
t_{off}	Turn-off Time (LMV118)			560		ns
TH_{SD}	Shut-down Threshold (LMV118)	$I_S \leq 50\mu A$		1.95	2.3	V
I_{SD}	Shutdown Pin Input Current (LMV118)	(Note 7)		-20		μA

5V Electrical Characteristics

Unless otherwise specified, all limits guaranteed for at $T_J = 25^\circ C$, $V^+ = 5V$, $V^- = 0V$, $V_{CM} = V_O = V^+/2$, and $R_F = 2k\Omega$, and $R_L = 1k\Omega$ to $V^+/2$. **Boldface** limits apply at the temperature extremes.

Symbol	Parameter	Conditions	Min (Note 6)	Typ (Note 5)	Max (Note 6)	Units
V_{OS}	Input Offset Voltage	$0V \leq V_{CM} \leq 1.7V$		± 1	± 5 ± 6	mV
TC V_{OS}	Input Offset Average Drift	(Note 12)		± 5		$\mu V/C$
I_B	Input Bias Current	(Note 7)	-2.0 -2.2	-0.40		μA
I_{OS}	Input Offset Current			1	500	nA
CMRR	Common Mode Rejection Ratio	V_{CM} Stepped from 0V to 3.8V	77	85		dB
PSRR	Power Supply Rejection Ratio	$V^+ = 5V$ to 6V or $V^- = 0V$ to -1V	72	95		dB
R_{IN}	Common Mode Input Resistance			3		$M\Omega$
C_{IN}	Common Mode Input Capacitance			2		pF
CMVR	Input Common-Mode Voltage Range	CMRR $\geq 50dB$	-0.3 -0.1		4.0	V
A_{VOL}	Large Signal Voltage Gain	$V_O = 1.5V$ to 3.5V	73 70	85		dB
V_O	Output Swing High	$R_L = 1k\Omega$ to $V^+/2$	4.80	4.95		V
		$R_L = 10k\Omega$ to $V^+/2$		4.98		
	Output Swing Low	$R_L = 1k\Omega$ to $V^+/2$	200	50		mV
		$R_L = 10k\Omega$ to $V^+/2$		20		
I_{SC}	Output Short Circuit Current	Sourcing to V^- $V_{ID} = 200mV$ (Note 10)	35	45		mA
		Sinking to V^+ $V_{ID} = -200mV$ (Note 10)	35	43		
I_{OUT}	Output Current	$V_{OUT} = 0.5V$ from rails		± 20		mA
I_S	Supply Current	Normal Operation		600	900	μA
		Shut-down Mode (LMV118)		10	50	
SR	Slew Rate (Note 8)	$A_V = +1$, $V_O = 1V_{PP}$		40		$V/\mu s$
BW	-3dB BW	$A_V = +1$, $V_{OUT} = 200mV_{PP}$		45		MHz
e_n	Input -Referred Voltage Noise	$f = 100kHz$		40		nV/\sqrt{Hz}
		$f = 1kHz$		60		
i_n	Input-Referred Current Noise	$f = 100kHz$		0.75		pA/\sqrt{Hz}
		$f = 1kHz$		1.20		
t_{on}	Turn-on Time (LMV118)			210		ns
t_{off}	Turn-off Time (LMV118)			500		ns
TH_{SD}	Shut-down Threshold (LMV118)	$I_S \leq 50\mu A$		4.25	4.60	V
I_{SD}	Shutdown Pin Input Current (LMV118)	(Note 7)		-20		μA

±5V Electrical Characteristics

Unless otherwise specified, all limits guaranteed for at $T_J = 25^\circ\text{C}$, $V^+ = 5\text{V}$, $V^- = -5\text{V}$, $V_{\text{CM}} = V_O = 0\text{V}$, and $R_F = 2\text{k}\Omega$, and $R_L = 1\text{k}\Omega$ to $V^+/2$. **Boldface** limits apply at the temperature extremes.

Symbol	Parameter	Conditions	Min (Note 6)	Typ (Note 5)	Max (Note 6)	Units
V_{OS}	Input Offset Voltage	$-5\text{V} \leq V_{\text{CM}} \leq 1.7\text{V}$		±1	±5 ±6	mV
TC V_{OS}	Input Offset Average Drift	(Note 12)		±5		μV/C
I_{B}	Input Bias Current	(Note 7)	-2.0 -2.2	-0.40		μA
I_{OS}	Input Offset Current			3	500	nA
CMRR	Common Mode Rejection Ratio	V_{CM} Stepped from -5V to 3.5V	78	104		dB
PSRR	Power Supply Rejection Ratio	$V^+ = 5\text{V}$ to 6V or $V^- = -5\text{V}$ to -6V	72	95		dB
R_{IN}	Common Mode Input Resistance			3		MΩ
C_{IN}	Common Mode Input Capacitance			2		pF
CMVR	Input Common-Mode Voltage Range	CMRR ≥ 50dB	-5.3 -5.1		4.0	V
A_{VOL}	Large Signal Voltage Gain	$V_O = -2\text{V}$ to 2V	74 71	85		dB
V_O	Output Swing High	$R_L = 1\text{k}\Omega$	4.70	4.92		V
		$R_L = 10\text{k}\Omega$		4.97		
	Output Swing Low	$R_L = 1\text{k}\Omega$	-4.70	-4.93		mV
		$R_L = 10\text{k}\Omega$		-4.98		
I_{SC}	Output Short Circuit Current	Sourcing to 0V $V_{\text{ID}} = 200\text{mV}$ (Note 10)	40	57		mA
		Sinking to 0V $V_{\text{ID}} = -200\text{mV}$ (Note 10)	40	54		
I_{OUT}	Output Current	$V_{\text{OUT}} = 0.5\text{V}$ from rails		±20		mA
I_{S}	Supply Current	Normal Operation		600	900	μA
		Shut-down Mode (LMV118)		15	50	
SR	Slew Rate (Note 8)	$A_V = +1$, $V_O = 1V_{\text{PP}}$		35		V/μs
BW	-3dB BW	$A_V = +1$, $V_{\text{OUT}} = 200\text{mV}_{\text{PP}}$		45		MHz
e_{n}	Input -Referred Voltage Noise	$f = 100\text{kHz}$		40		$\text{nV}/\sqrt{\text{Hz}}$
		$f = 1\text{kHz}$		60		
i_{n}	Input-Referred Current Noise	$f = 100\text{kHz}$		0.75		$\text{pA}/\sqrt{\text{Hz}}$
		$f = 1\text{kHz}$		1.20		
t_{on}	Turn-on Time (LMV118)			200		ns
t_{off}	Turn-off Time (LMV118)			700		ns
TH_{SD}	Shut-down Threshold (LMV118)	$I_{\text{S}} \leq 50\mu\text{A}$		4.25	4.60	V
I_{SD}	Shutdown Pin Input Current (LMV118)	(Note 7)		-20		μA

Note 1: Absolute Maximum Ratings indicate limits beyond which damage to the device may occur. Operating Ratings indicate conditions for which the device is intended to be functional, but specific performance is not guaranteed. For guaranteed specifications and the test conditions, see the Electrical Characteristics.

Note 2: Human body model, 1.5kΩ in series with 100pF.

Note 3: Applies to both single-supply and split-supply operation. Continuous short circuit operation at elevated ambient temperature can result in exceeding the maximum allowed junction temperature of 150°C.

Note 4: The maximum power dissipation is a function of $T_{\text{J(MAX)}}$, θ_{JA} , and T_{A} . The maximum allowable power dissipation at any ambient temperature is $P_{\text{D}} = (T_{\text{J(MAX)}} - T_{\text{A}}) / \theta_{\text{JA}}$. All numbers apply for packages soldered directly onto a PC board.

Note 5: Typical values represent the most likely parametric norm.

Note 6: All limits are guaranteed by testing or statistical analysis.

Note 7: Positive current corresponds to current flowing into the device.

Note 8: Slew rate is the average of the rising and falling slew rates.

Note 9: Machine Model, 0Ω in series with 200pF.

Note 10: Short circuit test is a momentary test. See Note 11.

Note 11: Output short circuit duration is infinite for $V_S < 6V$ at room temperature and below. For $V_S > 6V$, allowable short circuit duration is 1.5ms.

Note 12: Offset voltage average drift determined by dividing the change in V_{OS} at temperature extremes into the total temperature change.

Note 13: Guaranteed based on characterization only.

Connection Diagrams

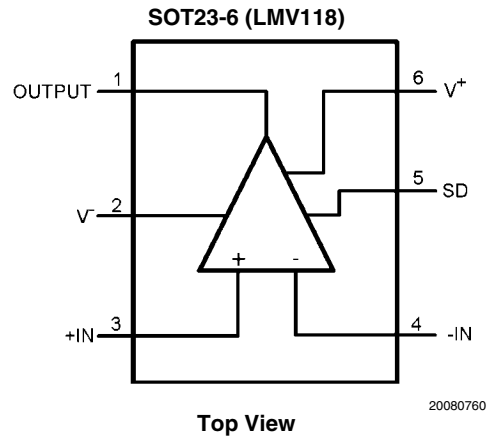
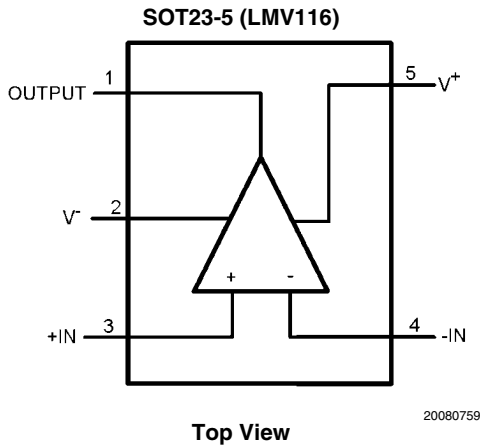

Ordering Information

Package	Part Number	Package Marking	Transport Media	NSC Drawing
5-Pin SOT-23	LMV116MF	AC1A	1k Units Tape and Reel	MF05A
	LMV116MFX		3k Units Tape and Reel	
6-Pin SOT-23	LMV118MF	AD1A	1k Units Tape and Reel	MF06A
	LMV118MFX		3k Units Tape and Reel	

Typical Performance Characteristics At $T_J = 25^\circ\text{C}$. Unless otherwise specified.

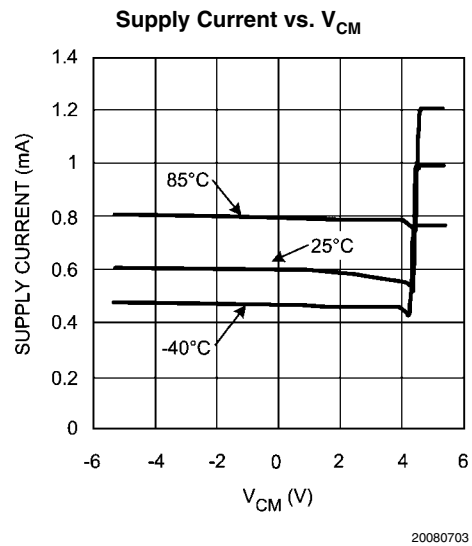
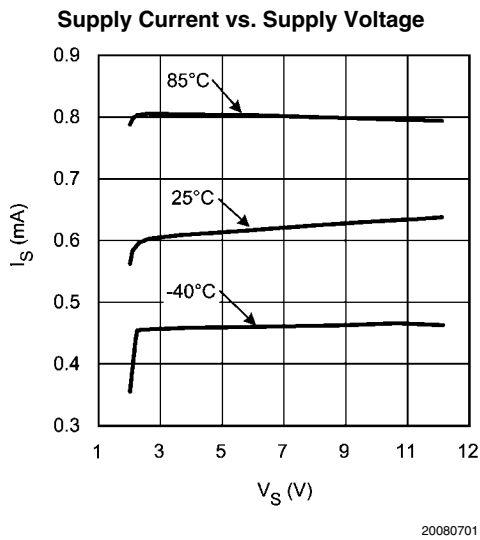

Gain and Phase vs. Frequency

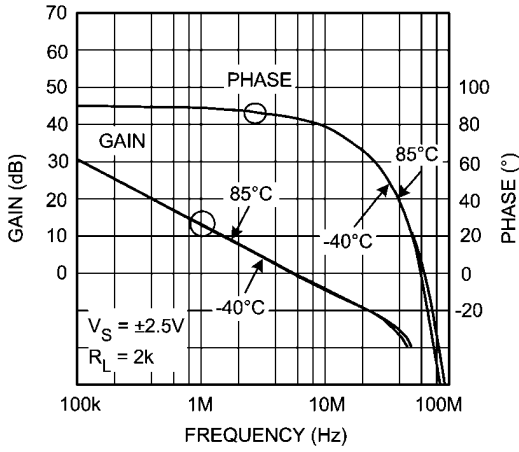

20080719

CMRR vs. Frequency

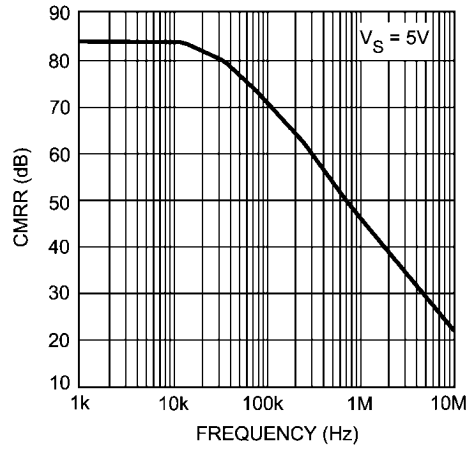

20080720

PSRR vs. Frequency

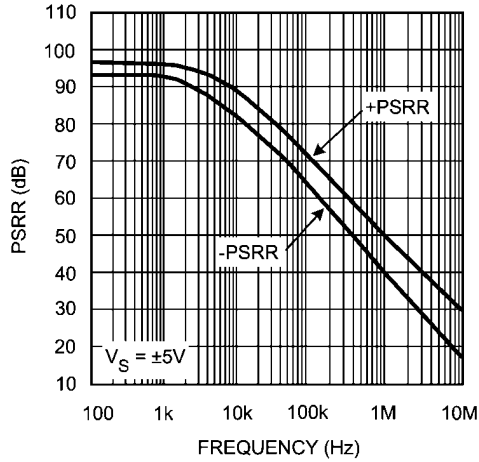

20080713

Input Voltage Noise vs. Frequency

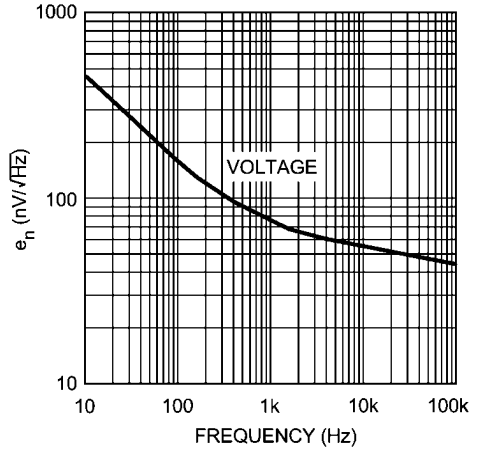

20080718

Input Current Noise vs. Frequency

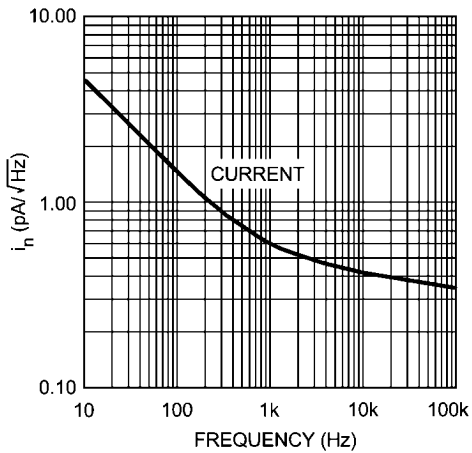

20080717

Closed Loop Frequency Response for Various Temperature

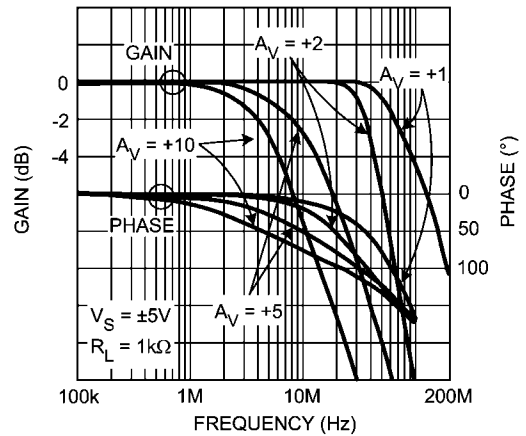

20080716

Frequency Response for Various (A_V)

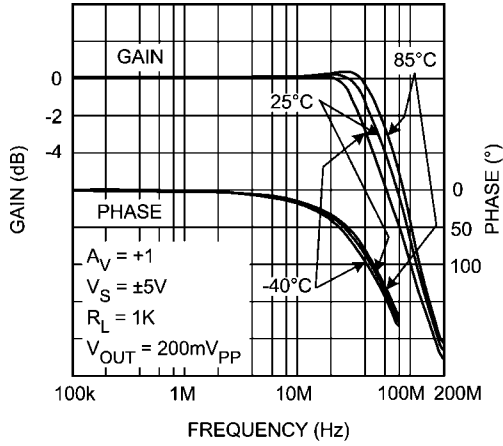

20080715

Large Signal Step Response

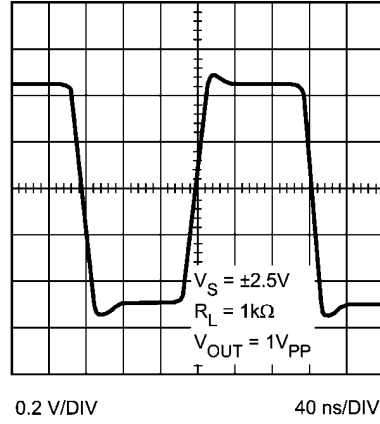

20080714

Offset Voltage vs. Common Mode Voltage (A Typical Unit)

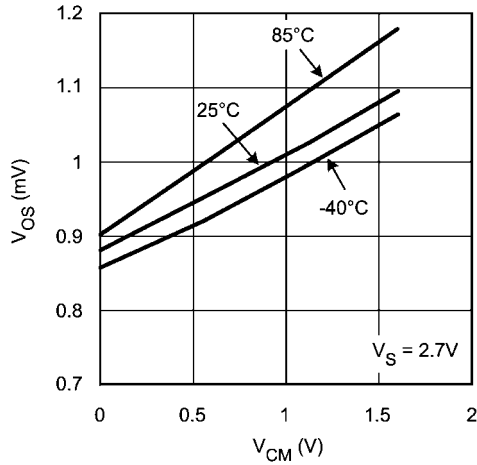

20080705

Offset Voltage vs. Common Mode Voltage (A Typical Unit)

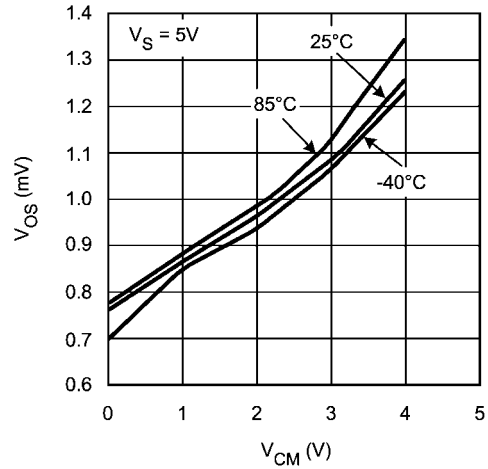

20080706

Offset Voltage vs. Common Mode Range (A Typical Unit)

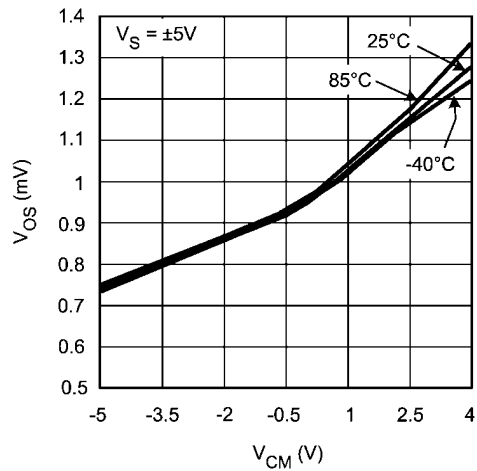

20080707

Input Bias Current vs. Supply Voltage

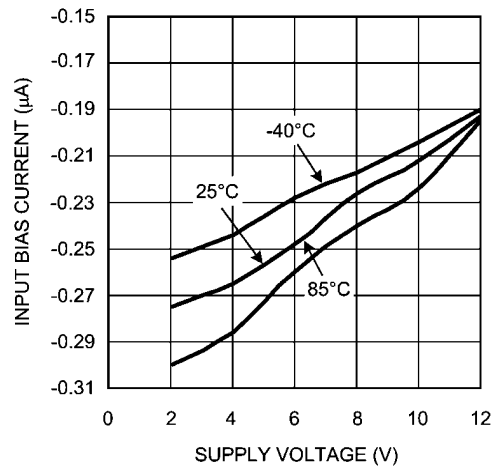

20080702

Input Bias Current vs. V_{CM}

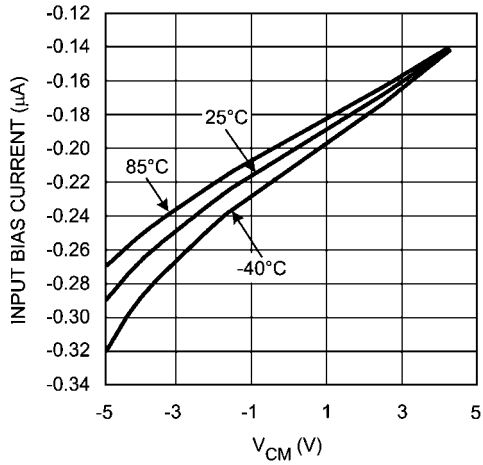

20080708

Sink Current vs. V_{OUT}

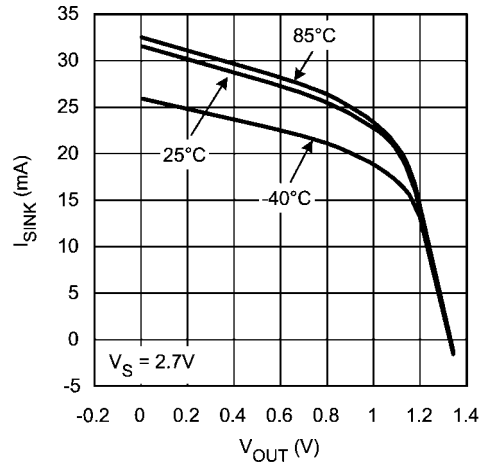

20080710

Sink Current vs. V_{OUT}

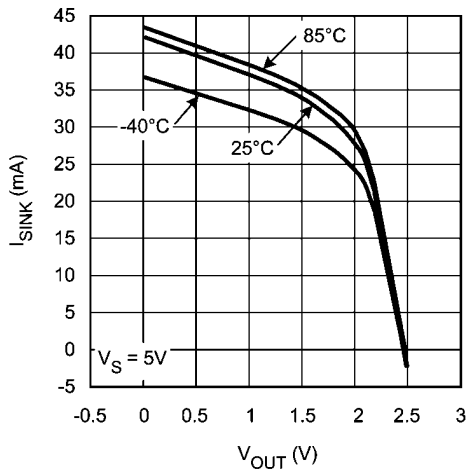

20080709

Source Current vs. V_{OUT}

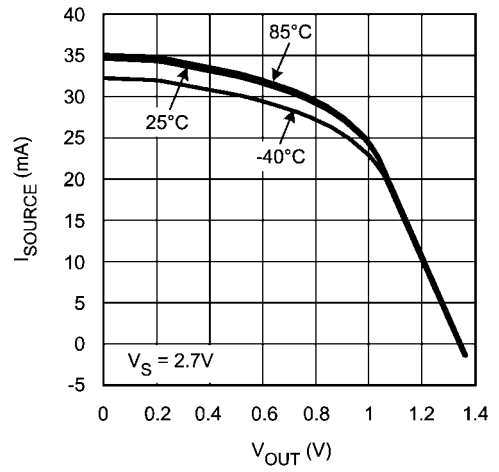

20080712

Source Current vs. V_{OUT}

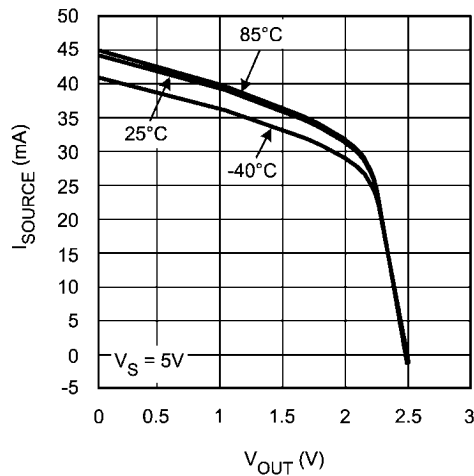

20080711

Application Notes

CIRCUIT DESCRIPTION

The LMV116 and LMV118 are based on National Semiconductor's proprietary VIP10 dielectrically isolated bipolar process.

The LMV116 and LMV118 architecture features the following:

- Complimentary bipolar devices with exceptionally high f_t (~8GHz) even under low supply voltage (2.7V) and low Collector bias current.
- Common Emitter push-pull output stage capable of 20mA output current (at 0.5V from the supply rails) while consuming only 600 μ A of total supply current. This architecture allows output to reach within milli-volts of either supply rail at light loads.
- Consistent performance from any supply voltage (2.7V-10V) with little variation with supply voltage for the most important specifications (e.g. BW, SR, I_{OUT} , etc.)

APPLICATION HINTS

When the output swing approaches either supply rail, the output transistor will enter a Quasi-saturated state. A subtle effect of this operational region is that there is an increase in supply current in this state (up to 1 mA). The onset of Quasi-saturation region is a function of output loading (current) and varies from 100 mV at no load to about 1V when output is delivering 20 mA, as measured from supplies. Both input common mode voltage and output voltage level effect the supply current (see typical performance characteristics for plot).

MICRO-POWER SHUTDOWN

The LMV118 can be shutdown to save power and reduce its supply current to less than 50 μ A guaranteed, by applying a voltage to the SD pin. The SD pin is "active high" and needs to be tied to V^- for normal operation. This input is low current (<20 μ A, 4pF equivalent capacitance) and a resistor to V^- ($\leq 20k\Omega$) will result in normal operation. Shutdown is guaranteed when SD pin is 0.4V or less from V^+ at any operating supply voltage and temperature.

In the shutdown mode, essentially all internal device biasing is turned off in order to minimize supply current flow and the output goes into Hi-Z (high impedance) mode. Complete device Turn-on and Turn-off times vary considerably relative to the output loading conditions, output voltage, and input impedance, but is generally limited to less than 1 μ s (see tables for actual data).

During shutdown, the input stage has an equivalent circuit as shown below in [Figure 1](#)

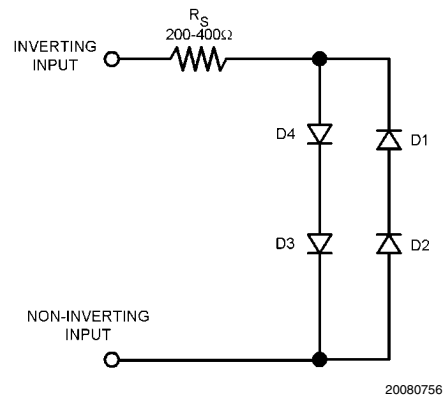

FIGURE 1. LMV118 Equivalent Input in Shutdown Mode

As can be seen above, in shutdown, there may be current flow through the internal diodes shown, caused by input potential, if present. This current may flow through the external feedback resistor and result in an apparent output signal. In most shutdown applications the presence of this output is inconsequential. However, if the output is "forced" by another device such as in a multiplexer, the other device will need to conduct the current described in order to maintain the output potential.

To keep the output at or near ground during shutdown when there is no other device to hold the output low, a switch (transistor) could be used to shunt the output to ground. [Figure 2](#) shows a circuit where a NPN bipolar is used to keep the output near ground (~80mV):

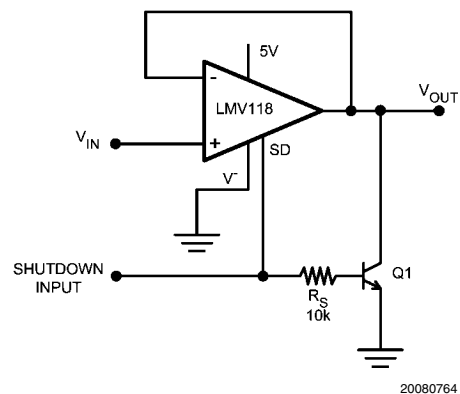
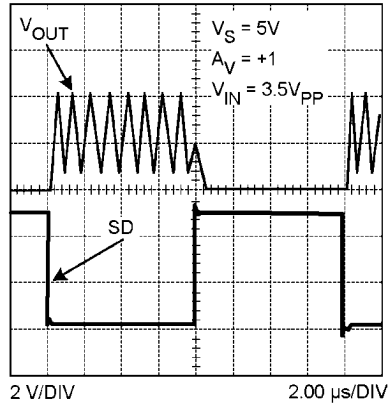

FIGURE 2. Active Pull-Down Schematic

[Figure 3](#) shows the output waveform.



20080736

FIGURE 3. Output Held Low by Active Pull-Down Circuit

If bipolar transistor power dissipation is not tolerable, the switch could be by a N-channel enhancement mode MOSFET.

2.7V SINGLE SUPPLY 2:1 MUX

The schematic show in Figure 4 will function as a 2:1 MUX operating on a single 2.7V power supply, by utilizing the shut-down feature of the LMV118.

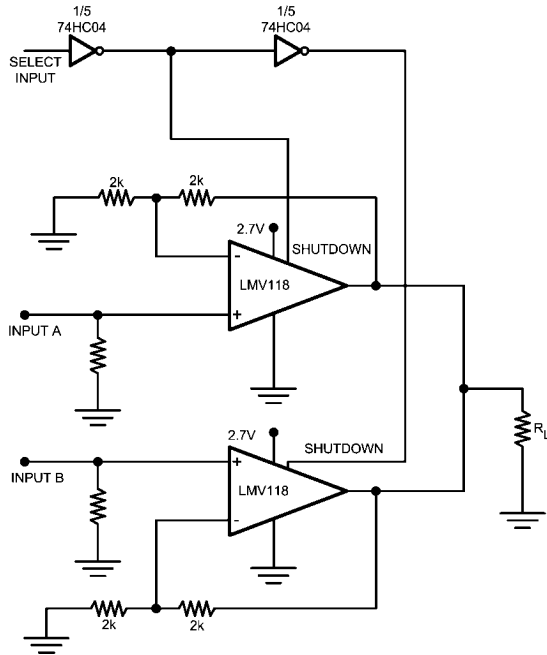

20080758

FIGURE 4. 2:1 MUX Operating off a 2.7V Single Supply

Figure 5 shows the MUX output when selecting between a 1MHz sine and a 250kHz triangular waveform.

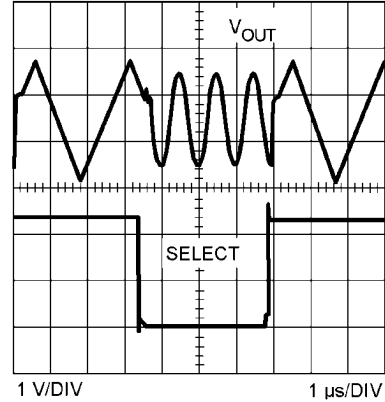

20080735

FIGURE 5. 2:1 MUX Output

As can be seen in Figure 5, the output is well behaved and there are no spikes or glitches due to the switching. Switching times are approximately around 500ns based on the time when the output is considered "valid".

PRINTED CIRCUIT BOARD LAYOUT, COMPONENT VALUES SELECTION, AND EVALUATION BOARDS

Generally, a good high-frequency layout will keep power supply and ground traces away from the inverting input and output pins. Parasitic capacitances on these nodes to ground will cause frequency response peaking and possible circuit oscillations (see Application Note OA-15 for more information).

Another important parameter, is the component values selection. Choosing large valued external resistors, will effect the closed loop behavior of the stage because of the interaction of these resistors with parasitic capacitances. These capacitors could be inherent to the device or a by-product of the board layout and component placement. Either way, keeping the resistor values lower, will diminish this interac-

tion. On the other hand, choosing very low value resistors could load down nodes and will contribute to higher overall power dissipation.

National Semiconductor suggests the following evaluation boards as a guide for high frequency layout and as an aid in device testing and characterization:

Device	Package	Evaluation Board PN
LMV116	SOT23-5	CLC730068
LMV118	SOT23-6	CLC730116

These free evaluation boards are shipped when a device sample request is placed with National Semiconductor.

Physical Dimensions inches (millimeters) unless otherwise noted

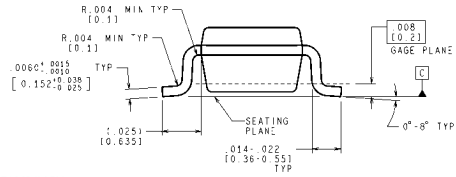
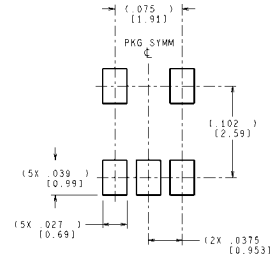
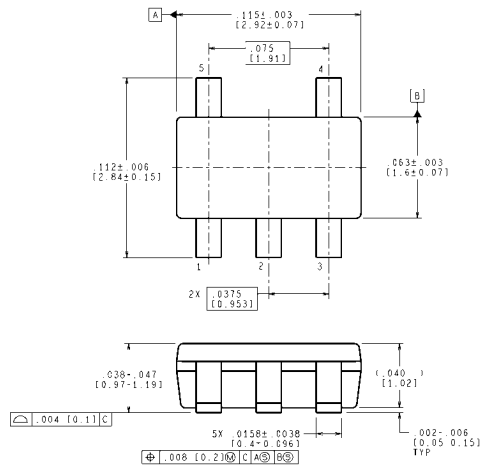

CONTROLLING DIMENSION IS INCH
VALUES IN [] ARE MILLIMETERS
DIMENSIONS IN () FOR REFERENCE ONLY

MF05A (Rev D)

**5-Pin SOT23
NS Package Number MF05A**

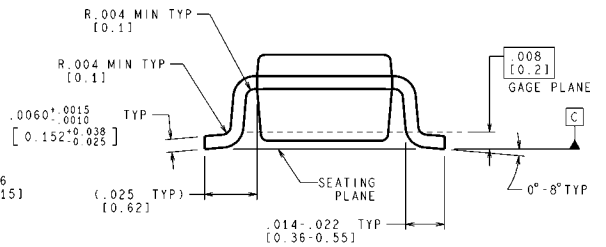
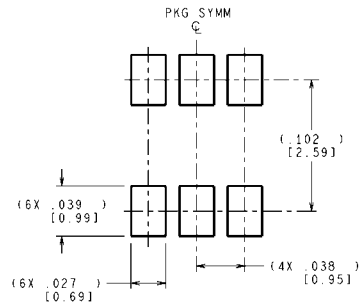
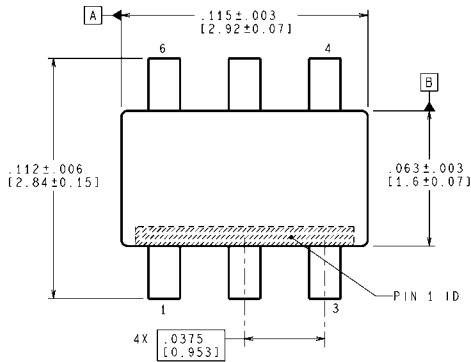

CONTROLLING DIMENSION IS INCH
VALUES IN [] ARE MILLIMETERS
DIMENSIONS IN () FOR REFERENCE ONLY

MF06A (Rev C)

**6-Pin SOT23
NS Package Number MF06A**

Notes

Notes

For more National Semiconductor product information and proven design tools, visit the following Web sites at:
www.national.com

Products		Design Support	
Amplifiers	www.national.com/amplifiers	WEBENCH® Tools	www.national.com/webench
Audio	www.national.com/audio	App Notes	www.national.com/appnotes
Clock and Timing	www.national.com/timing	Reference Designs	www.national.com/refdesigns
Data Converters	www.national.com/adc	Samples	www.national.com/samples
Interface	www.national.com/interface	Eval Boards	www.national.com/evalboards
LVDS	www.national.com/lvds	Packaging	www.national.com/packaging
Power Management	www.national.com/power	Green Compliance	www.national.com/quality/green
Switching Regulators	www.national.com/switchers	Distributors	www.national.com/contacts
LDOs	www.national.com/ldo	Quality and Reliability	www.national.com/quality
LED Lighting	www.national.com/led	Feedback/Support	www.national.com/feedback
Voltage References	www.national.com/vref	Design Made Easy	www.national.com/easy
PowerWise® Solutions	www.national.com/powerwise	Applications & Markets	www.national.com/solutions
Serial Digital Interface (SDI)	www.national.com/sdi	Mil/Aero	www.national.com/milaero
Temperature Sensors	www.national.com/tempensors	SolarMagic™	www.national.com/solarmagic
PLL/VCO	www.national.com/wireless	PowerWise® Design University	www.national.com/training

THE CONTENTS OF THIS DOCUMENT ARE PROVIDED IN CONNECTION WITH NATIONAL SEMICONDUCTOR CORPORATION ("NATIONAL") PRODUCTS. NATIONAL MAKES NO REPRESENTATIONS OR WARRANTIES WITH RESPECT TO THE ACCURACY OR COMPLETENESS OF THE CONTENTS OF THIS PUBLICATION AND RESERVES THE RIGHT TO MAKE CHANGES TO SPECIFICATIONS AND PRODUCT DESCRIPTIONS AT ANY TIME WITHOUT NOTICE. NO LICENSE, WHETHER EXPRESS, IMPLIED, ARISING BY ESTOPPEL OR OTHERWISE, TO ANY INTELLECTUAL PROPERTY RIGHTS IS GRANTED BY THIS DOCUMENT.

TESTING AND OTHER QUALITY CONTROLS ARE USED TO THE EXTENT NATIONAL DEEMS NECESSARY TO SUPPORT NATIONAL'S PRODUCT WARRANTY. EXCEPT WHERE MANDATED BY GOVERNMENT REQUIREMENTS, TESTING OF ALL PARAMETERS OF EACH PRODUCT IS NOT NECESSARILY PERFORMED. NATIONAL ASSUMES NO LIABILITY FOR APPLICATIONS ASSISTANCE OR BUYER PRODUCT DESIGN. BUYERS ARE RESPONSIBLE FOR THEIR PRODUCTS AND APPLICATIONS USING NATIONAL COMPONENTS. PRIOR TO USING OR DISTRIBUTING ANY PRODUCTS THAT INCLUDE NATIONAL COMPONENTS, BUYERS SHOULD PROVIDE ADEQUATE DESIGN, TESTING AND OPERATING SAFEGUARDS.

EXCEPT AS PROVIDED IN NATIONAL'S TERMS AND CONDITIONS OF SALE FOR SUCH PRODUCTS, NATIONAL ASSUMES NO LIABILITY WHATSOEVER, AND NATIONAL DISCLAIMS ANY EXPRESS OR IMPLIED WARRANTY RELATING TO THE SALE AND/OR USE OF NATIONAL PRODUCTS INCLUDING LIABILITY OR WARRANTIES RELATING TO FITNESS FOR A PARTICULAR PURPOSE, MERCHANTABILITY, OR INFRINGEMENT OF ANY PATENT, COPYRIGHT OR OTHER INTELLECTUAL PROPERTY RIGHT.

LIFE SUPPORT POLICY

NATIONAL'S PRODUCTS ARE NOT AUTHORIZED FOR USE AS CRITICAL COMPONENTS IN LIFE SUPPORT DEVICES OR SYSTEMS WITHOUT THE EXPRESS PRIOR WRITTEN APPROVAL OF THE CHIEF EXECUTIVE OFFICER AND GENERAL COUNSEL OF NATIONAL SEMICONDUCTOR CORPORATION. As used herein:

Life support devices or systems are devices which (a) are intended for surgical implant into the body, or (b) support or sustain life and whose failure to perform when properly used in accordance with instructions for use provided in the labeling can be reasonably expected to result in a significant injury to the user. A critical component is any component in a life support device or system whose failure to perform can be reasonably expected to cause the failure of the life support device or system or to affect its safety or effectiveness.

National Semiconductor and the National Semiconductor logo are registered trademarks of National Semiconductor Corporation. All other brand or product names may be trademarks or registered trademarks of their respective holders.

Copyright© 2010 National Semiconductor Corporation

For the most current product information visit us at www.national.com



National Semiconductor Americas Technical Support Center
 Email: support@nsc.com
 Tel: 1-800-272-9959

National Semiconductor Europe Technical Support Center
 Email: europe.support@nsc.com

National Semiconductor Asia Pacific Technical Support Center
 Email: ap.support@nsc.com

National Semiconductor Japan Technical Support Center
 Email: jpn.feedback@nsc.com