

19205

6	5	4	3	2	
MATERIAL NO.	ENG. NO.	WIRE SIZE	I.D. MIN.	O.D. MAX.	"L" (E)
192070001	AS-302	22-18	.060/1.50	.130/3.30	.305/.325 (7.75/8.26)
192050001	BS-304	16-14	.091/2.30	.160/4.10	.295/.315 (7.50/8.00)
192050003	CS-303	12-10	.130/3.30	.225/5.70	.295/.315 (7.50/8.00)
192050004	D-355	8	.165/4.20	.295/7.50	.360/.390 (9.14/9.91)
192050006	E-361	6	.230/5.80	.374/9.50	.430/.460 (10.92/11.68)
192050007	F-365	4	.277/7.00	.457/11.60	.500/.530 (12.70/13.46)
192050008	G-373	2	.357/9.00	.538/13.70	.635/.665 (16.13/16.89)
192050009	H-384	1/0	.439/11.20	.620/15.70	.735/.765 (18.67/19.43)
192050010	J-389	2/0	.496/12.60	.697/17.70	.725/.755 (18.42/19.18)
192150049	K-394	3/0	.545/13.80	.760/19.30	.735/.765 (18.67/19.43)
192150050	L-379	4/0	.621/15.80	.860/21.80	.760/.790 (19.30/20.07)

D

D

C

C

B

B

NOTE(S):

1. MATERIAL: COPPER
2. PLATING: ELECTRO-TIN

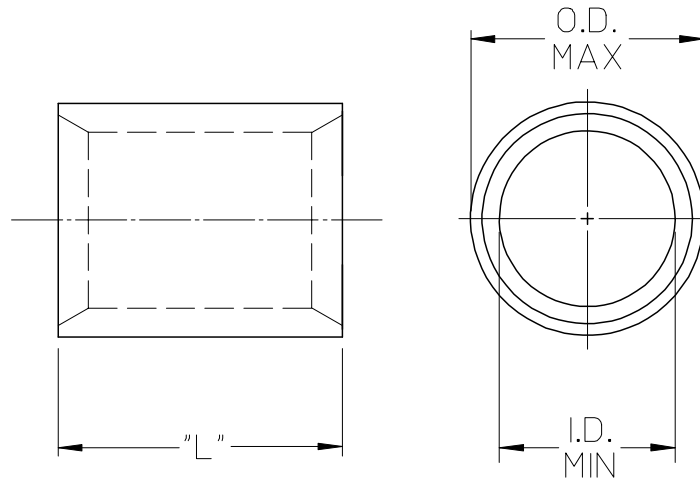

SALES DRAWING

A

A

REV'D "L" DIM EC NO: ETC2008-0020 DRWN:RSTONE 2007/08/17 CHKD:JMACNEIL 2007/08/20 APPR:JMACNEIL 2007/08/20	QUALITY SYMBOLS	GENERAL TOLERANCES (UNLESS SPECIFIED)		SCALE 2:1	DESIGN UNITS INCH	THIRD ANGLE PROJECTION	REVISE ON CAD ONLY	
		4 PLACES	mm	INCH	DIMENSION STYLE IN/MM		TITLE VERSAKRIMP SEAMLESS PARALLEL CONNECTORS	
		3 PLACES	± ---	± ---	DRAWN BY DLM	DATE 03/07/08		
		2 PLACES	± ---	± ---	CHECKED BY HEB	DATE 03/07/08	MOLEX INCORPORATED	
1 PLACE	± ---	± ---	ANGULAR ±1/2°	APPROVED BY RWD	DATE 03/07/08	MATERIAL NO. (SEE CHART)	DOCUMENT NO. SD-19205-007	
		DRAFT WHERE APPLICABLE MUST REMAIN WITHIN DIMENSIONS		SHEET NO. 1 OF 1				
THIS DRAWING CONTAINS INFORMATION THAT IS PROPRIETARY TO MOLEX INCORPORATED AND SHOULD NOT BE USED WITHOUT WRITTEN PERMISSION								

A