

CUSTOMER PRINT

PART NUMBER: CARA16280XSXXX90

- NOTES:
 1. FINISHED CABLE ASSEMBLY TO BE COILED
 2. OVERMOLD BOOT MATERIAL: PVC, BLACK
 3. ELECTRICAL TEST: 100% CONTINUITY

ASS'Y P/N	NO. OF POSITION	"X" DIM.
CARA162802S07990	2 POS.	6 FT. 7 IN. ± 2 IN. [2M]
CARA162803S07990	3 POS.	
CARA16280XSXXX90		

CABLE LENGTH IN "INCHES"
 NO OF POSITIONS

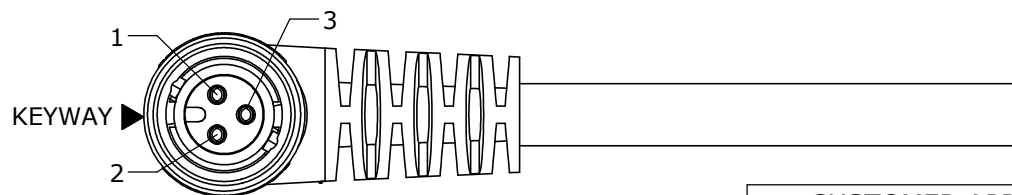
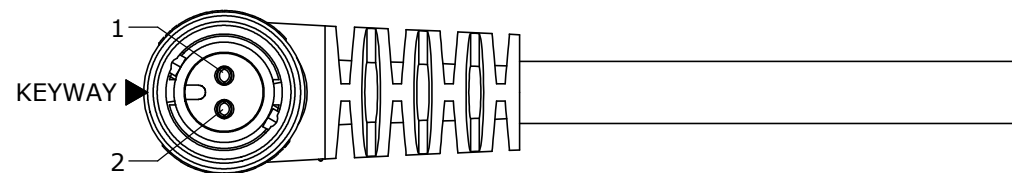
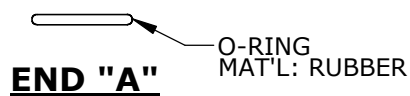
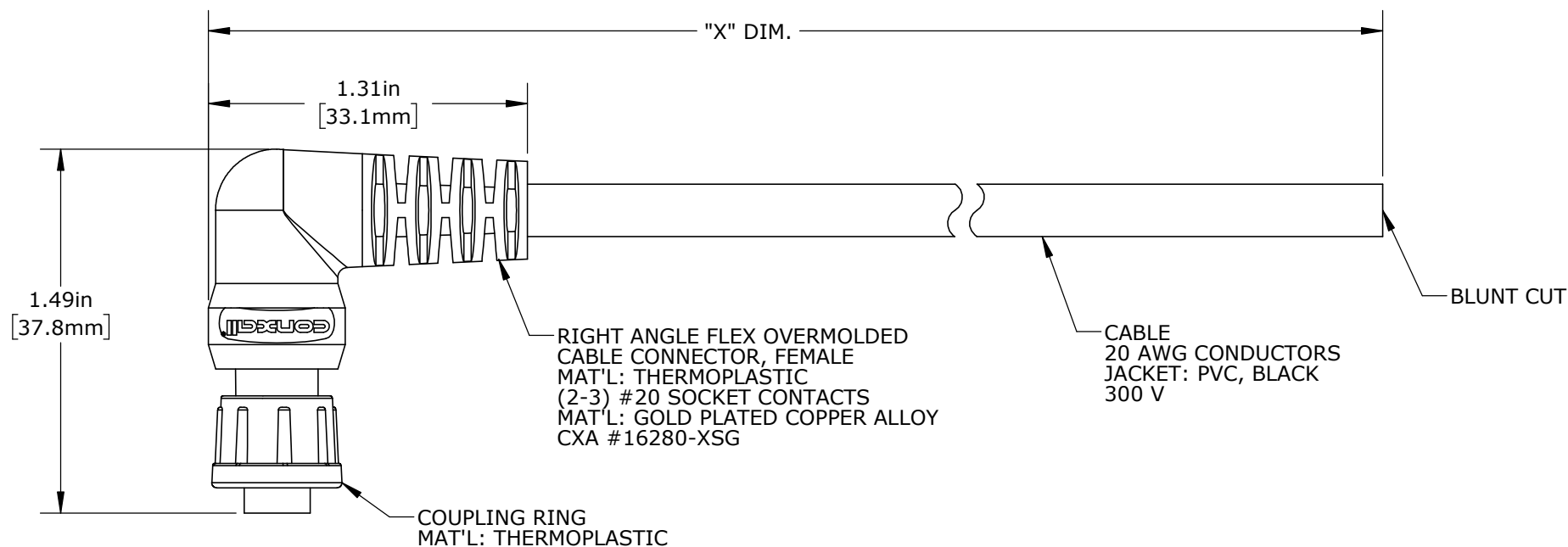

DIMENSIONS IN BRACKET [] ARE METRIC.

CUSTOMER APPROVAL
 THIS DOCUMENT CONTAINS CONFIDENTIAL INFORMATION PROPRIETARY TO CONXALL CORPORATION. ANY REPRODUCTION, DISCLOSURE, OR USE OF THIS DOCUMENT /INFORMATION IS EXPRESSLY PROHIBITED UNLESS AUTHORIZED IN WRITING BY CONXALL CORPORATION.
 APPROVED BY: _____
 DATE: _____

RoHS COMPLIANT

ASSY P/N	CABLE	COLOR CODE END "A"		
CARA162802SXXX90	2/20 AWG O.D. 0.215 REF	COLOR CODE		
		POS. 1	POS. 2	
		BLK	WHT	
CARA162803SXXX90	3/20 AWG O.D. 0.220 REF	WIRE COLOR CODE		
		POS. 1	POS. 2	POS. 3
		BLK	WHT	GRN

REV.	INIT.	DATE	DESCRIPTION
B	AB	11-03-20	NEW FLEX OVERMOLD PER DOR 19-SQ104238JS
A	AN	11-07-16	DRAWING CREATED PER DOR 16-7663JP

ALL INFORMATION ILLUSTRATED IS THE PROPERTY OF "CONXALL CORPORATION". UNAUTHORIZED DUPLICATION OR DISTRIBUTION OF THIS DOCUMENT IS PROHIBITED.	ORIG. DRAWN BY: AN DATE: 11-07-16 CHECKED BY:	 601 E. WILDWOOD VILLA PARK, IL 60181
ALL UNITS ARE IN FEET, INCHES, FRACTIONS OF INCHES AND DECIMALS.	APPROVED BY: TITLE: CABLE ASSEMBLY (2-3) #20 SOCKET CONTACTS MICRO-CON-X, R ANGLE STANDARD PRODUCT CUSTOMER:	
FILE: CARA16280XSXXX90	DIRECTORY: SLW	SCALE: NTS SIZE: B SHEET: 1 OF 1 PART NUMBER: CARA16280XSXXX90