

- NOTES:
- MATERIAL:
    - HOUSING: LCP, BLACK, UL94V-0;
    - TERMINAL: COPPER ALLOY, THICKNESS: 0.15mm;
    - SHELL: STAINLESS STEEL, THICKNESS: 0.30mm.
  - PLATING:
    - TERMINAL:
      - CONTACT AREA: GOLD FLASH OVER 0.75 MICRON MINIMUM Pd/Ni;
      - SOLDER TAIL AREA: GOLD FLASH; UNDER PLATING: NICKEL 2.0 MICRON MINIMUM.
    - SHELL:
      - 1.27 MICRON MINIMUM NICKEL UNDER PLATING,
      - 1.5 MICRON MINIMUM MATTE TIN PLATING OVERALL,
      - 0.133 MICRON MINIMUM BLACK NICKEL SELECT PLATING FRONT PORTION,
      - NO BLACK NICKEL PLATING ON SOLDERING TABS.
  - TAIL & NAIL COPLANARITY 0.08mm MAXIMUM.
  - PRODUCT SPECIFICATION: PS-47642-001.
  - PACKAGING SPECIFICATION: PK-47642-001.
  - PRODUCT COMPLIANT TO RoHS DIRECTIVE 2002/95/EC AND ELV 2000/53/EC.

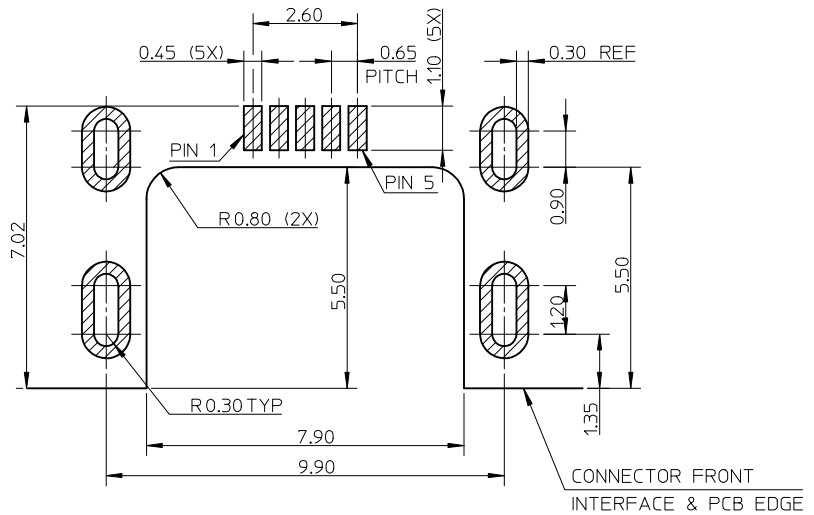

RECOMMENDED P.C.B. PATTERN LAYOUT  
GENERAL TOLERANCE: ±0.05

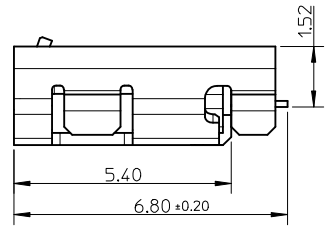
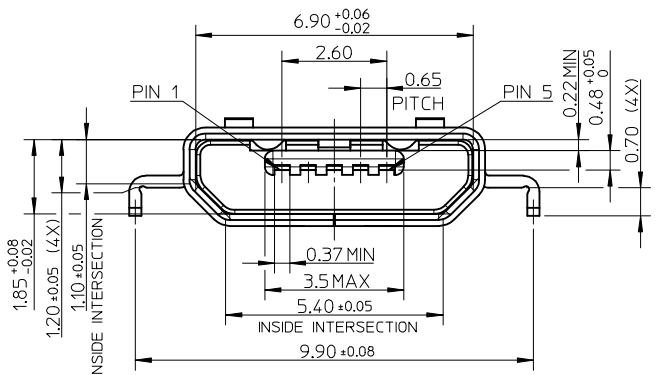
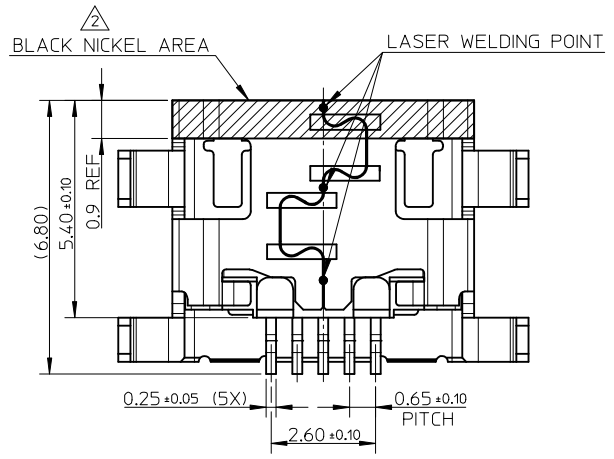

<p><b>NEW RELEASE</b>                  EC NO: SHZ014-0097                  DRWN: XQZHANG                  CHKD: XQZHANG                  APPR: AYIN</p>	<p>2013/09/02                  2013/09/02                  2013/09/03</p>	<p>QUALITY SYMBOLS  <math>F_A = 0</math>  <math>F_B = 0</math>  <math>F_C = 0</math></p>	<p>GENERAL TOLERANCES (UNLESS SPECIFIED)</p> <table border="1"> <thead> <tr> <th></th> <th>mm</th> <th>INCH</th> </tr> </thead> <tbody> <tr> <td>4 PLACES</td> <td>± ---</td> <td>± ---</td> </tr> <tr> <td>3 PLACES</td> <td>± ---</td> <td>± ---</td> </tr> <tr> <td>2 PLACES</td> <td>± 0.20</td> <td>± ---</td> </tr> <tr> <td>1 PLACE</td> <td>± 0.25</td> <td>± ---</td> </tr> <tr> <td>0 PLACE</td> <td>± ---</td> <td>± ---</td> </tr> </tbody> </table>		mm	INCH	4 PLACES	± ---	± ---	3 PLACES	± ---	± ---	2 PLACES	± 0.20	± ---	1 PLACE	± 0.25	± ---	0 PLACE	± ---	± ---	<p>DIMENSION STYLE  <b>MM ONLY</b></p>	<p>SCALE  <b>1:1</b></p>	<p>DESIGN UNITS  <b>METRIC</b></p>	<p>THIRD ANGLE PROJECTION</p>
		mm	INCH																						
	4 PLACES	± ---	± ---																						
	3 PLACES	± ---	± ---																						
2 PLACES	± 0.20	± ---																							
1 PLACE	± 0.25	± ---																							
0 PLACE	± ---	± ---																							
<p>REV  <b>A</b></p>	<p>DESCRIPTION</p>	<p>DRAFT WHERE APPLICABLE MUST REMAIN WITHIN DIMENSIONS</p>	<p>GENERAL TOLERANCES (UNLESS SPECIFIED)</p> <p>ANGULAR ± 3°</p>	<p>DRAWN BY                  XQZHANG</p> <p>CHECKED BY                  XQZHANG</p> <p>APPROVED BY                  AYIN</p>	<p>DATE                  2013/03/18</p> <p>DATE                  2013/03/18</p> <p>DATE                  2013/09/03</p>	<p>TITLE                  SALES DRAWING FOR USB MICRO-B, MID MOUNT BLACK NICKEL PLATING</p>																			
	<p>MATERIAL NO.  <b>105248-1002</b></p>	<p>DOCUMENT NO.  <b>SD-105248-102</b></p>	<p>SHEET NO.                  1 OF 1</p>	<p>THIS DRAWING CONTAINS INFORMATION THAT IS PROPRIETARY TO MOLEX INCORPORATED AND SHOULD NOT BE USED WITHOUT WRITTEN PERMISSION</p>																					

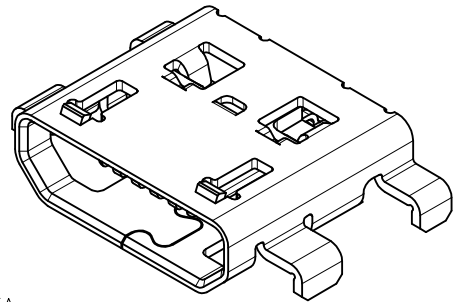
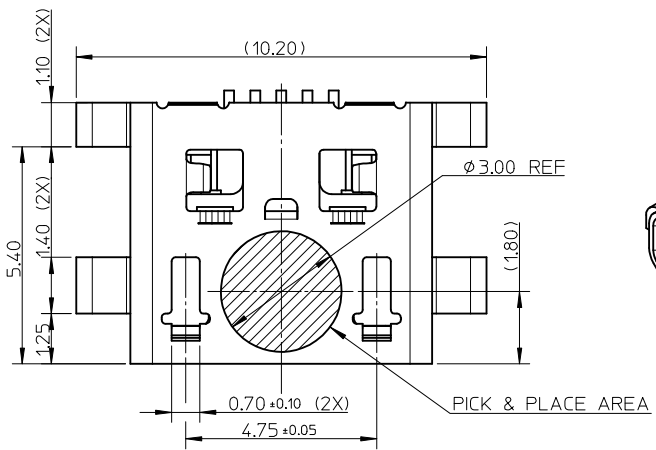

NOTES:

- MATERIAL:  
HOUSING: LCP, BLACK, UL94V-0;  
TERMINAL: COPPER ALLOY, THICKNESS: 0.15mm;  
SHELL: STAINLESS STEEL, THICKNESS: 0.30mm.
- PLATING:  
TERMINAL:  
CONTACT AREA: GOLD FLASH OVER 0.75 MICRON MINIMUM Pd/Ni;  
SOLDER TAIL AREA: GOLD FLASH; UNDER PLATING: NICKEL 2.0 MICRON MINIMUM.  
SHELL:  
1.27 MICRON MINIMUM NICKEL UNDER PLATING,  
1.5 MICRON MINIMUM MATTE TIN PLATING OVERALL,  
0.133 MICRON MINIMUM BLACK NICKEL SELECT PLATING FRONT PORTION,  
NO BLACK NICKEL PLATING ON SOLDERING TABS.
- TAIL & NAIL COPLANARITY 0.08mm MAXIMUM.
- PRODUCT SPECIFICATION: PS-47642-001.
- PACKAGING SPECIFICATION: PK-47642-001.
- PRODUCT COMPLIANT TO RoHS DIRECTIVE 2002/95/EC AND ELV 2000/53/EC.

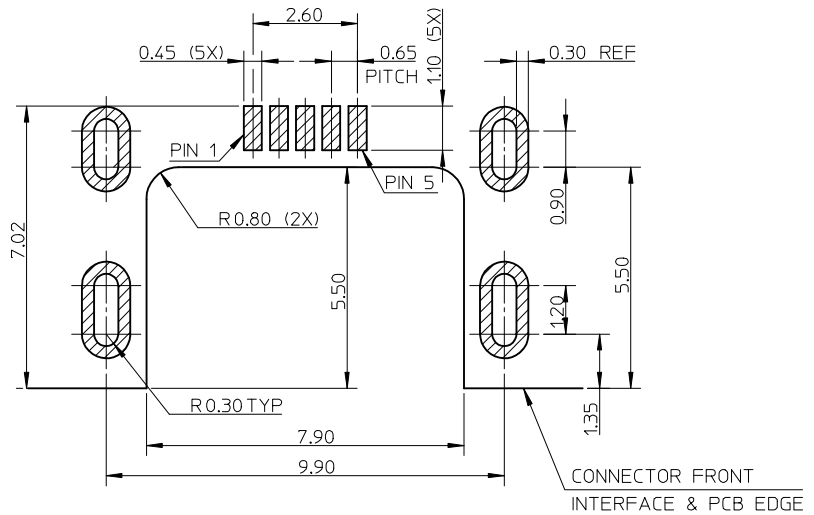
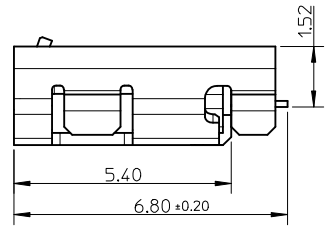
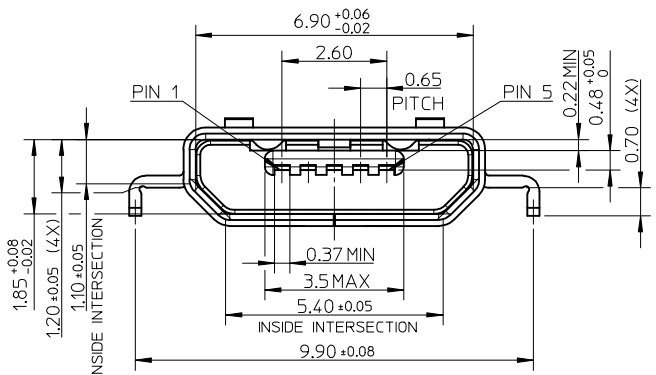

RECOMMENDED P.C.B. PATTERN LAYOUT  
GENERAL TOLERANCE: ±0.05

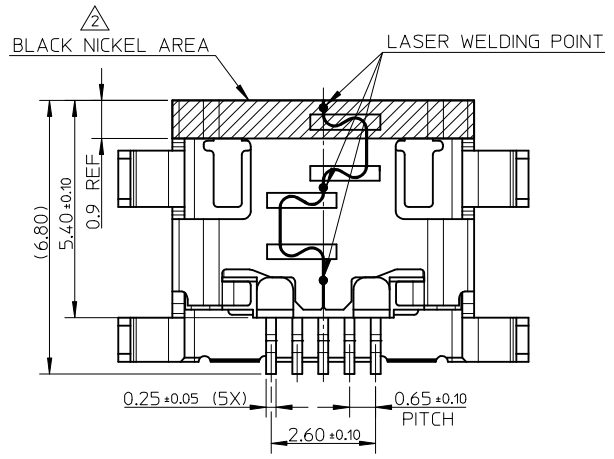

<p><b>NEW RELEASE</b> EC NO: SHZ014-0097 DRWN: XQZHANG 2013/09/02 CHKD: XQZHANG 2013/09/02 APPR: AYIN 2013/09/03</p>	QUALITY SYMBOLS	GENERAL TOLERANCES (UNLESS SPECIFIED)		DIMENSION STYLE <b>MM ONLY</b>		SCALE <b>1:1</b>	DESIGN UNITS <b>METRIC</b>	THIRD ANGLE PROJECTION
	$F_A = 0$	4 PLACES	mm	INCH	DRAWN BY XQZHANG	DATE 2013/03/18	TITLE SALES DRAWING FOR USB MICRO-B, MID MOUNT BLACK NICKEL PLATING	
	$F_B = 0$	3 PLACES	± ---	± ---	CHECKED BY XQZHANG	DATE 2013/03/18	<p><b>molex</b></p>	
	$F_C = 0$	2 PLACES	± 0.20	± ---	APPROVED BY AYIN	DATE 2013/09/03		
		1 PLACE	± 0.25	± ---	MATERIAL NO. <b>105248-1002</b>		THIS DRAWING CONTAINS INFORMATION THAT IS PROPRIETARY TO MOLEX INCORPORATED AND SHOULD NOT BE USED WITHOUT WRITTEN PERMISSION	
		0 PLACE	± ---	± ---	ANGULAR ± 3°			
		DRAFT WHERE APPLICABLE MUST REMAIN WITHIN DIMENSIONS		SIZE <b>A3</b>				