

SPECIFICATION CONTROL DRAWING

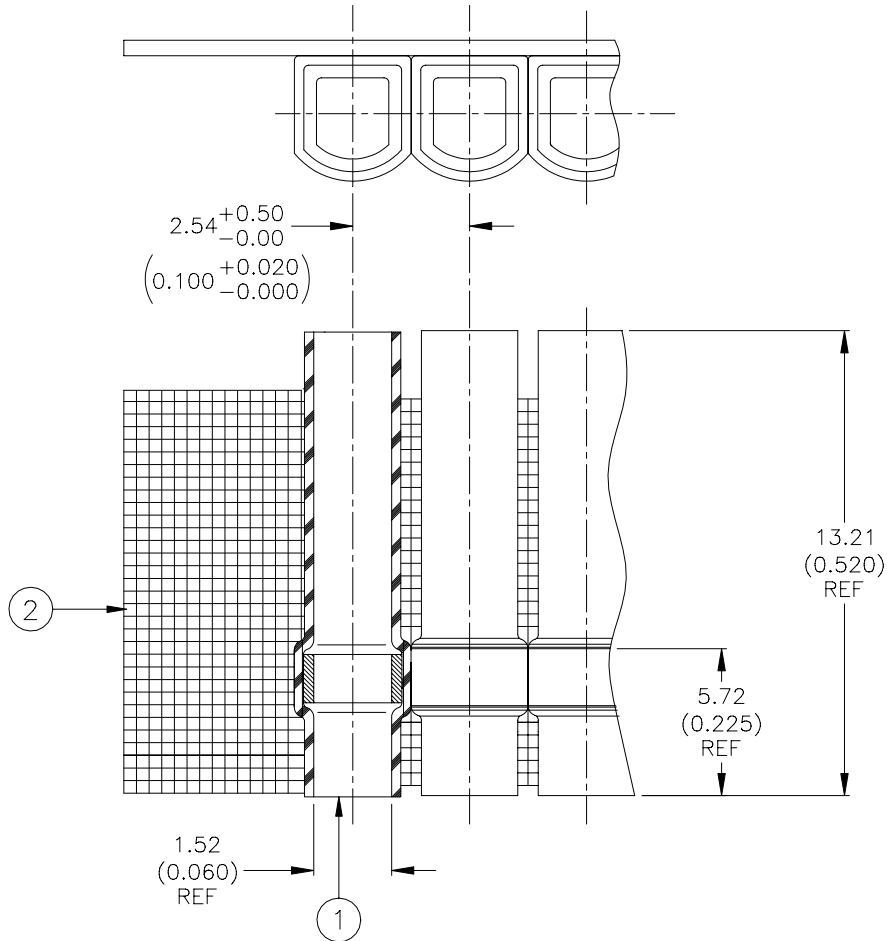

MATERIALS

1. SOLDER SLEEVE WIRE TERMINATOR: D-128-0034, Quantity Per Assembly: 500
2. CARRIER STRIP: Adhesive Coated High Temperature Tape

APPLICATION

1. This assembly is designed for use in conjunction with a Raychem AS-4000 Wire Organization System on connectors with terminals on 2.54 (0.100) center spacing. For usage parameters, see Raychem Devices Specification Control Drawing D-128-0034.
2. Wire terminators are to be inspected to Raychem Devices Specification Control Drawing D-128-0034.

tyco <i>Electronics</i>		Raychem Products 305 Constitution Drive Menlo Park, CA 94025, USA		TITLE: SOLDERPAK ASSEMBLY FOR AS-4000 2.54mm .100in CENTERS, SLEEVE D-128-0034		
Unless otherwise specified dimensions are in millimeters. Inches dimensions are in between brackets.				DOCUMENT NO.: D-704-0049		
TOLERANCES: 0.00 N/A 0.0 N/A 0 N/A	ANGLES: N/A ROUGHNESS IN MICRON	Tyco Electronics reserves the right to amend this drawing at any time. Users should evaluate the suitability of the product for their application.		: PROD. REV A	DOC ISSUE 1	REV. DATE 17-Oct-02
PREPARED BY: mforonda	DCR Number D020472	Replaces N/A	SCALE: None	SIZE: A	SHEET: 1 of 1	

If this document is printed it becomes uncontrolled. Check for the latest revision.