

Product Document

TSL237T

High-Sensitivity Light-to-Frequency Converter

General Description

The TSL237 light-to-frequency converter combines a silicon photodiode and a current-to-frequency converter on a single monolithic CMOS integrated circuit. Output is a square wave (50% duty cycle) with frequency directly proportional to light intensity (irradiance) on the photodiode. The digital output allows direct interface to a microcontroller or other logic circuitry. Output enable (\overline{OE}) places the output in a high-impedance state for multiple-unit sharing of a microcontroller input line. The device has been temperature compensated for the ultraviolet-to-visible light range of 320nm to 700nm and responds over the light range of 320nm to 1050nm. The TSL237 is characterized for operation over the temperature range of -40°C to 85°C and is supplied in a compact 4-lead surface-mount package (T).

Ordering Information and Content Guide appear at end of datasheet.

Key Benefits & Features

The benefits and features of the TSL237, High Sensitivity Light-to-Frequency Converter, are listed below:

Figure 1:
Added Value of Using TSL237

Benefits	Features
<ul style="list-style-type: none"> High-Resolution Conversion of Light Intensity to Frequency with no External Components 	<ul style="list-style-type: none"> 5M:1 Input Dynamic Range
<ul style="list-style-type: none"> Provides Low Light Level Operation 	<ul style="list-style-type: none"> Low Dark Frequency of 0.1 Hz (typical), <2Hz at 50°C
<ul style="list-style-type: none"> Provides for High Sensitivity to Detect a Small Change in Light 	<ul style="list-style-type: none"> High Irradiance Responsivity 1.2kHz/($\mu\text{W}/\text{cm}^2$) @ $\lambda_p = 640\text{nm}$
<ul style="list-style-type: none"> Reduces Board Space Requirements while Simplifying Designs 	<ul style="list-style-type: none"> 2.6mm x 3.8mm 4-lead SMD (T) Package

- Single-Supply Operation: 2.7V to 5.5V
- Stable 200ppm/°C Temperature Coefficient
- Communicates Directly with a Microcontroller

Block Diagram

The functional blocks of this device are shown below:

Figure 2:
TSL237 Block Diagram

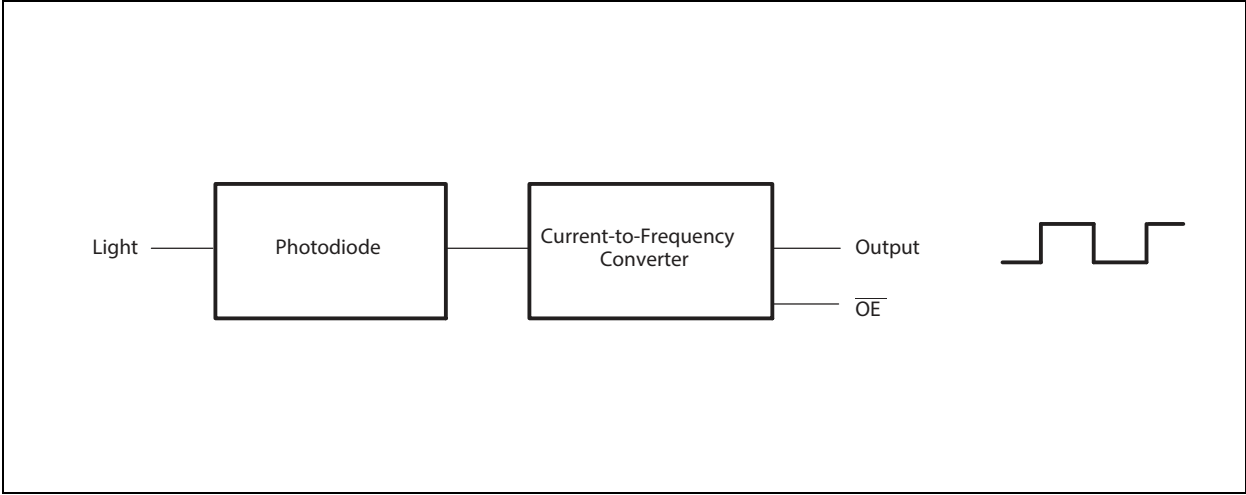

Pin Assignments

Figure 3:
Pin Diagram of Package T 4-Lead SMD (Top View)

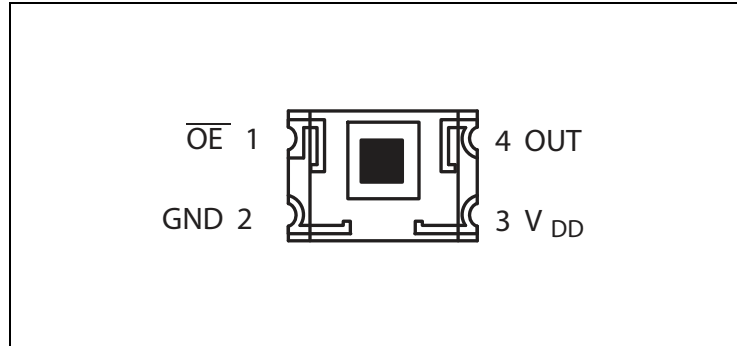

Figure 4:
Terminal Functions

Terminal		Type	Description
Name	Pin No.		
GND	2		Power supply ground (substrate). All voltages are referenced to GND.
$\overline{\text{OE}}$	1	I	Enable for f_O (active low)
OUT	4	O	Output frequency
V_{DD}	3		Supply voltage

Absolute Maximum Ratings

Stresses beyond those listed under [Absolute Maximum Ratings](#) may cause permanent damage to the device. These are stress ratings only. Functional operation of the device at these or any other conditions beyond those indicated under [Recommended Operating Conditions](#) is not implied. Exposure to absolute maximum rating conditions for extended periods may affect device reliability.

Figure 5:
Absolute Maximum Ratings Over Operating Free-Air Temperature Range (unless otherwise noted)

Symbol	Parameter	Min	Max	Unit
V_{DD}	Supply voltage ⁽¹⁾		6	V
V_I	Input voltage range, \overline{OE} input	-0.3	$V_{DD} + 0.3$	V
T_A	Operating free-air temperature range ⁽²⁾	-40	85	°C
T_{STRG}	Storage temperature range ⁽²⁾	-40	85	°C
T_{BODY}	Solder conditions in accordance with JEDEC J-STD-020A, maximum temperature		260	°C

Note(s):

1. All voltage values are with respect to GND.
2. Long-term storage or operation above 70°C could cause package yellowing that will lower the sensitivity to wavelengths < 500nm.

Electrical Characteristics

All limits are guaranteed. The parameters with min and max values are guaranteed with production tests or SQC (Statistical Quality Control) methods.

Figure 6:
Recommended Operating Conditions

Symbol	Parameter		Min	Typ	Max	Unit
V_{DD}	Supply voltage		2.7	5	5.5	V
V_{IH}	High-level input voltage	$V_{DD} = 5V$	4.5		V_{DD}	V
V_{IL}	Low-level input voltage	$V_{DD} = 5V$	0		0.5	V
T_A	Operating free-air temperature range		-40		85	°C

Figure 7:
Electrical Characteristics at $V_{DD} = 5V$, $T_A = 25^\circ C$ (unless otherwise noted)

Symbol	Parameter	Test Conditions	Min	Typ	Max	Unit
V_{OH}	High-level output voltage	$I_{OH} = -1mA$	4	4.7		V
V_{OL}	Low-level output voltage	$I_{OL} = 1mA$		0.1	0.4	V
I_{DD}	Supply current			1.6	3	mA
	Full-scale frequency ⁽¹⁾		500		1000	kHz
	Temperature coefficient of output frequency	Wavelength $\leq 600nm$, $f_O = 50kHz$		± 200		ppm/°C
k_{SVS}	Supply voltage sensitivity	$V_{DD} = 5V \pm 10\%$		± 0.5		%/V

Note(s):

1. Full-scale frequency is the maximum operating frequency of the device without saturation.

Figure 8:
Operating Characteristics at $V_{DD} = 5V$, $T_A = 25^\circ C$, $\lambda_p = 640nm$ (unless otherwise noted)

Symbol	Parameter	Test Conditions	Min	Typ	Max	Unit
f_O	Output frequency	$E_e = 40.4\mu W/cm^2$,	40	50	60	kHz
f_D	Dark frequency	$E_e = 0\mu W/cm^2$	0	0.1		Hz
		$E_e = 0\mu W/cm^2$, $T_A = 50^\circ C$	0		2	Hz
R_e	Irradiance responsivity			1.2		kHz/ ($\mu W/cm^2$)
	Nonlinearity ⁽¹⁾	$f_O = 0kHz$ to $10kHz$		$\pm 1\%$		%F.S.
	Step response to full-scale step input		1 pulse of new frequency plus $1\mu s$			
	Time from \overline{OE} low to output enabled		1 period of output frequency			

Note(s):

1. Nonlinearity is defined as the deviation of f_O from a straight line between zero and full scale, expressed as a percent of full scale.

Typical Operating Characteristics

Figure 9:
Output Frequency vs. Irradiance

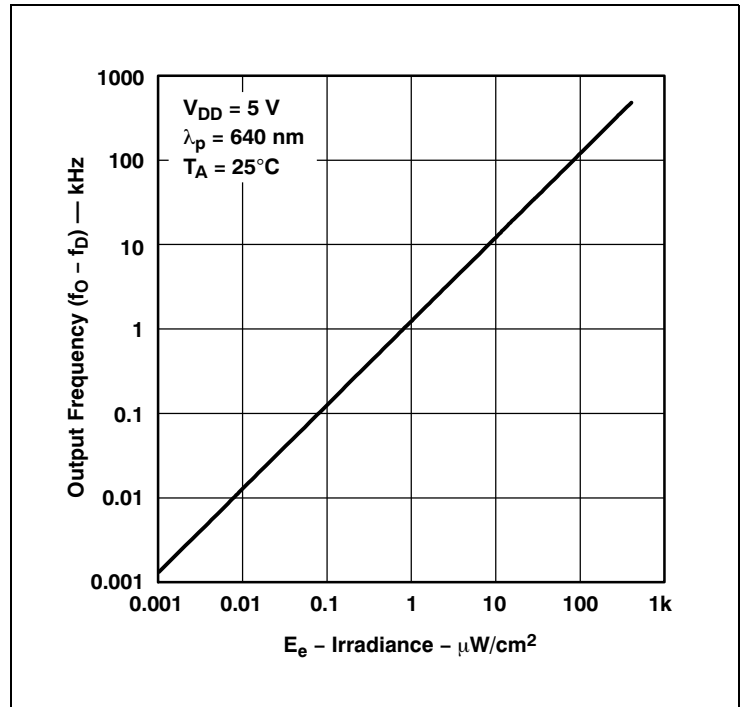

Figure 10:
Photodiode Spectral Responsivity

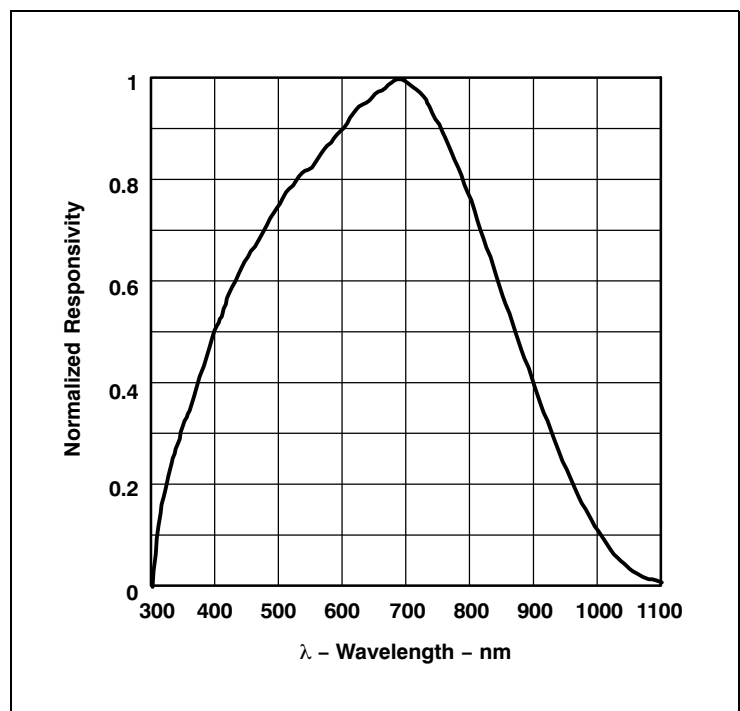

Figure 11:
Supply Current vs. Free-Air Temperature

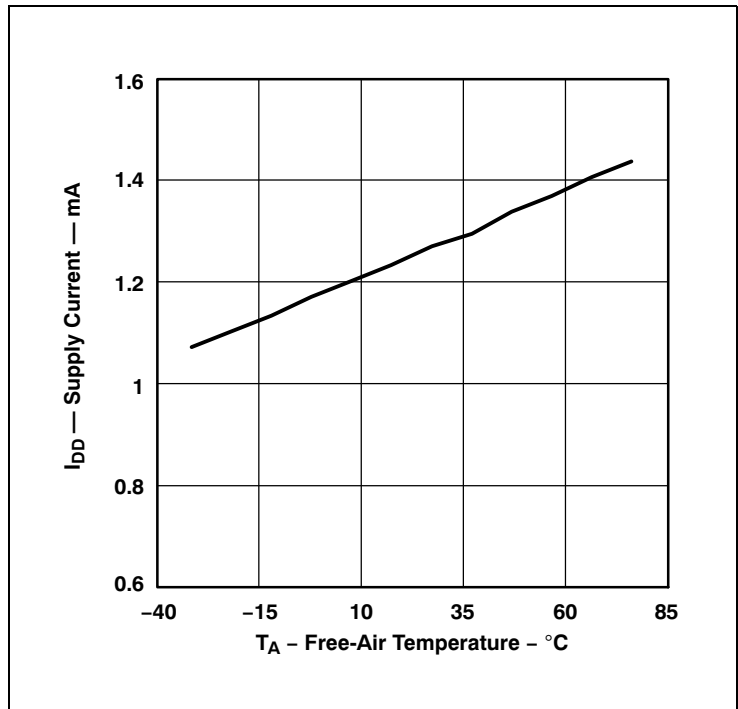

Figure 12:
Output Frequency vs. Free-Air Temperature

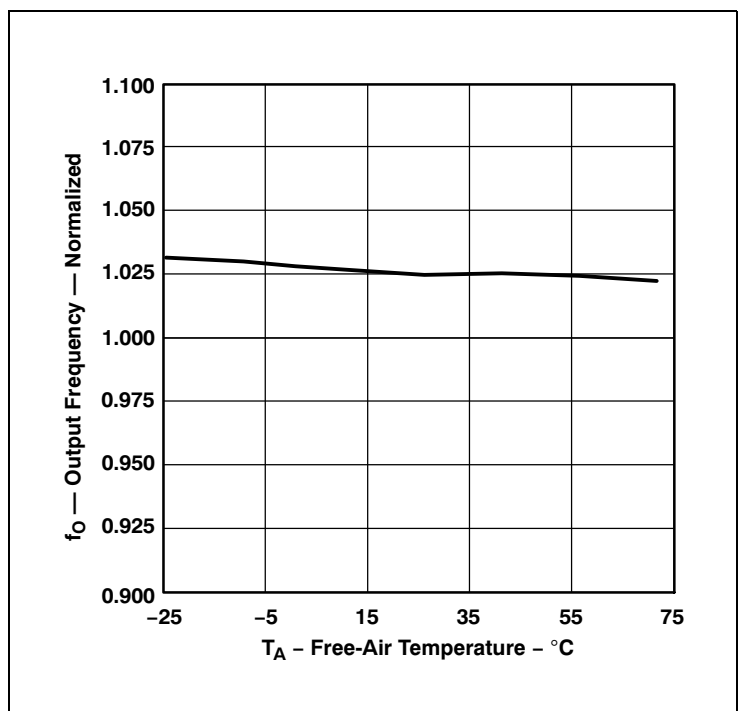
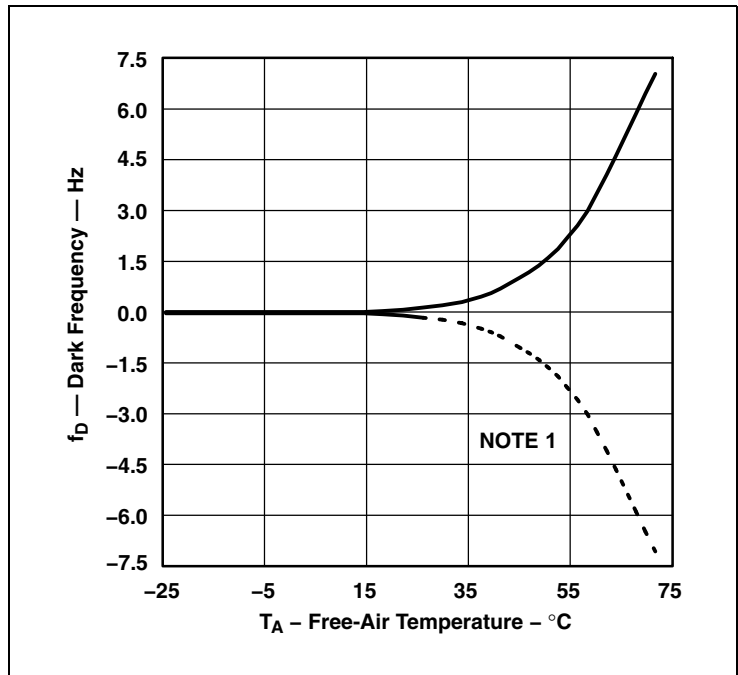

Figure 13:
Dark Frequency vs. Free-Air Temperature



Note(s):

- Internal offsets that result in dark frequency can be both positive and negative. The dashed line represents the case of negative offset in which an equivalent amount of light signal is required to obtain a non-zero output frequency.

Figure 14:
Photodiode Responsivity Temperature Coefficient vs. Wavelength of Incident Light

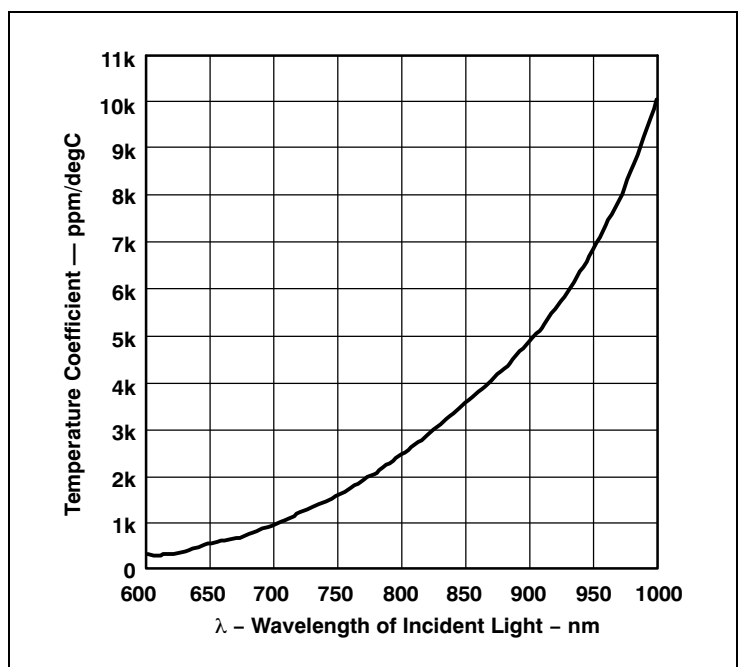

Figure 15:
Normalized Output Voltage vs. Angular Displacement -
T PKG

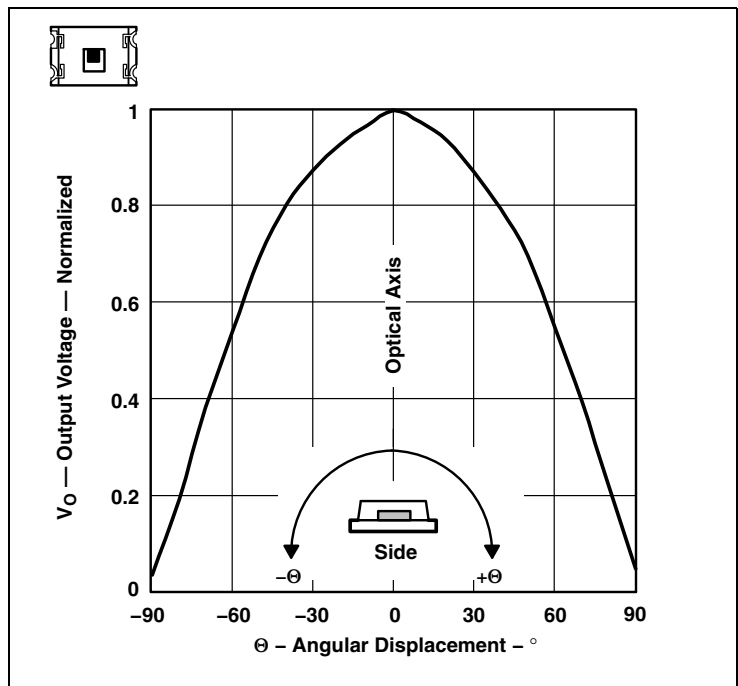
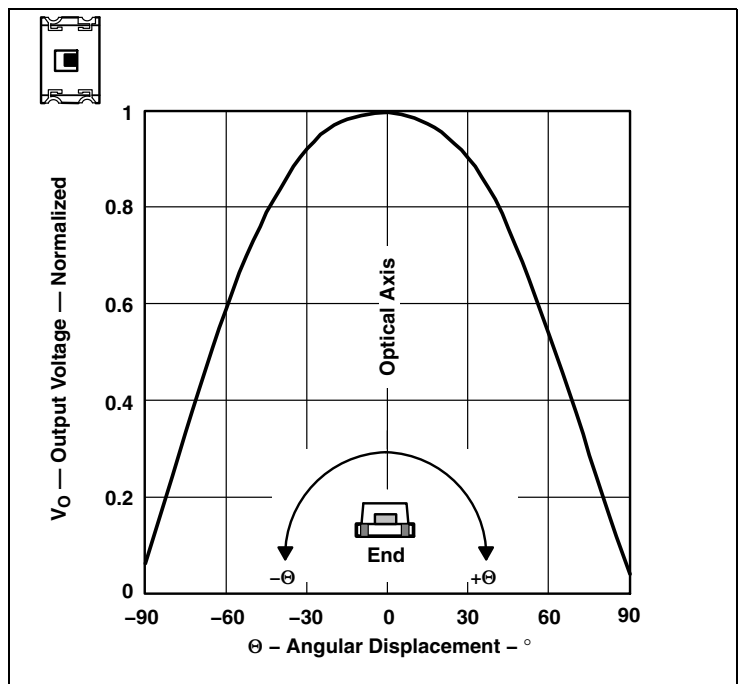

Figure 16:
Normalized Output Voltage vs. Angular Displacement -
T PKG



Application Information

Power-Supply Considerations

Power-supply lines must be decoupled by a 0.01 μF to 0.1 μF capacitor with short leads placed close to the TSL237 (Figure 17). A low-noise power supply is required to minimize jitter on output pulse.

Figure 17:
Typical TSL237 Interface to a Microcontroller

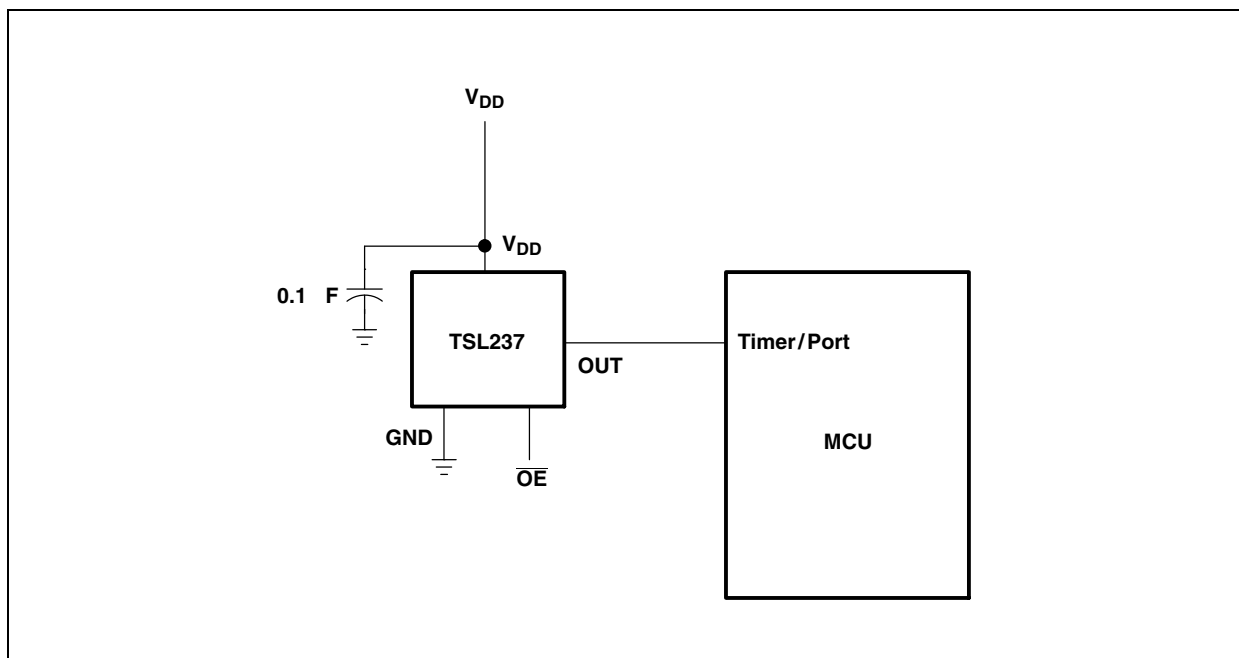

Device Operational Details

The frequency at the output pin (OUT) is given by:

$$(EQ1) \quad f_O = f_D + (R_e) (E_e)$$

where

- f_O is the output frequency
- f_D is the output frequency for dark condition ($E_e = 0$)
- R_e is the device responsivity for a given wavelength of light given in $\text{kHz}/(\mu\text{W}/\text{cm}^2)$
- E_e is the incident irradiance in $\mu\text{W}/\text{cm}^2$

f_D is a constant error term in the output frequency calculation resulting from leakage currents, and is independent of light intensity. The TSL237 die is trimmed to minimize the magnitude of this dark frequency component so that it can be neglected in the transfer function calculation.

In many applications, measurement of the actual dark frequency may be impractical due to measurement times ranging from several seconds to several minutes, and the fact that some devices may never transition (zero dark frequency).

Input Interface

A low-impedance electrical connection between the device \overline{OE} terminal and the device GND terminal is required for improved noise immunity.

Output Interface

The output of the device is designed to drive a CMOS logic input over short distances. If lines greater than 12 inches in length are used on the output, a buffer or line driver is recommended.

Measuring the Frequency

The choice of interface and measurement technique depends on the desired resolution and data acquisition rate. For maximum data-acquisition rate, period-measurement techniques are used.

Period measurement requires the use of a fast reference clock with available resolution directly related to reference-clock rate. The technique is employed to measure rapidly varying light levels or to make a fast measurement of a constant light source.

Maximum resolution and accuracy may be obtained using frequency-measurement, pulse-accumulation, or integration techniques. Frequency measurements provide the added benefit of averaging out random- or high-frequency variations (jitter) resulting from noise in the light signal. Resolution is limited mainly by available counter registers and allowable measurement time. Frequency measurement is well suited for slowly varying or constant light levels and for reading average light levels over short periods of time. Integration, the accumulation of pulses over a very long period of time, can be used to measure exposure - the amount of light present in an area over a given time period.

Output enable (\overline{OE}) places the output in a high-impedance state for multiple-unit sharing of a microcontroller input line. When the \overline{OE} line goes low, the device resynchronizes the output to an integration cycle. The rising edge of the output signal (OUT) will occur exactly one period of the output frequency after \overline{OE} goes low.

PCB Pad Layout

Suggested PCB pad layout guidelines for the T package are shown in [Figure 18](#).

Figure 18:
Suggested T Package PCB Layout

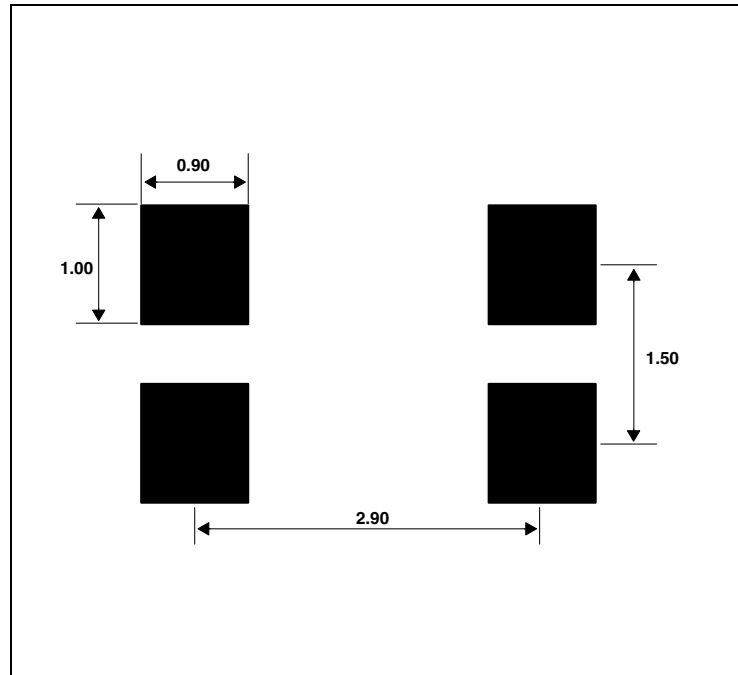

Note(s):

1. All linear dimensions are in millimeters.
2. This drawing is subject to change without notice.

Packaging Mechanical Data

The TSL237 is supplied in a low-profile surface-mount package. This package contains no lead (Pb).

Figure 19:
Package T - Four-Lead Surface Mount Device Packaging Configuration

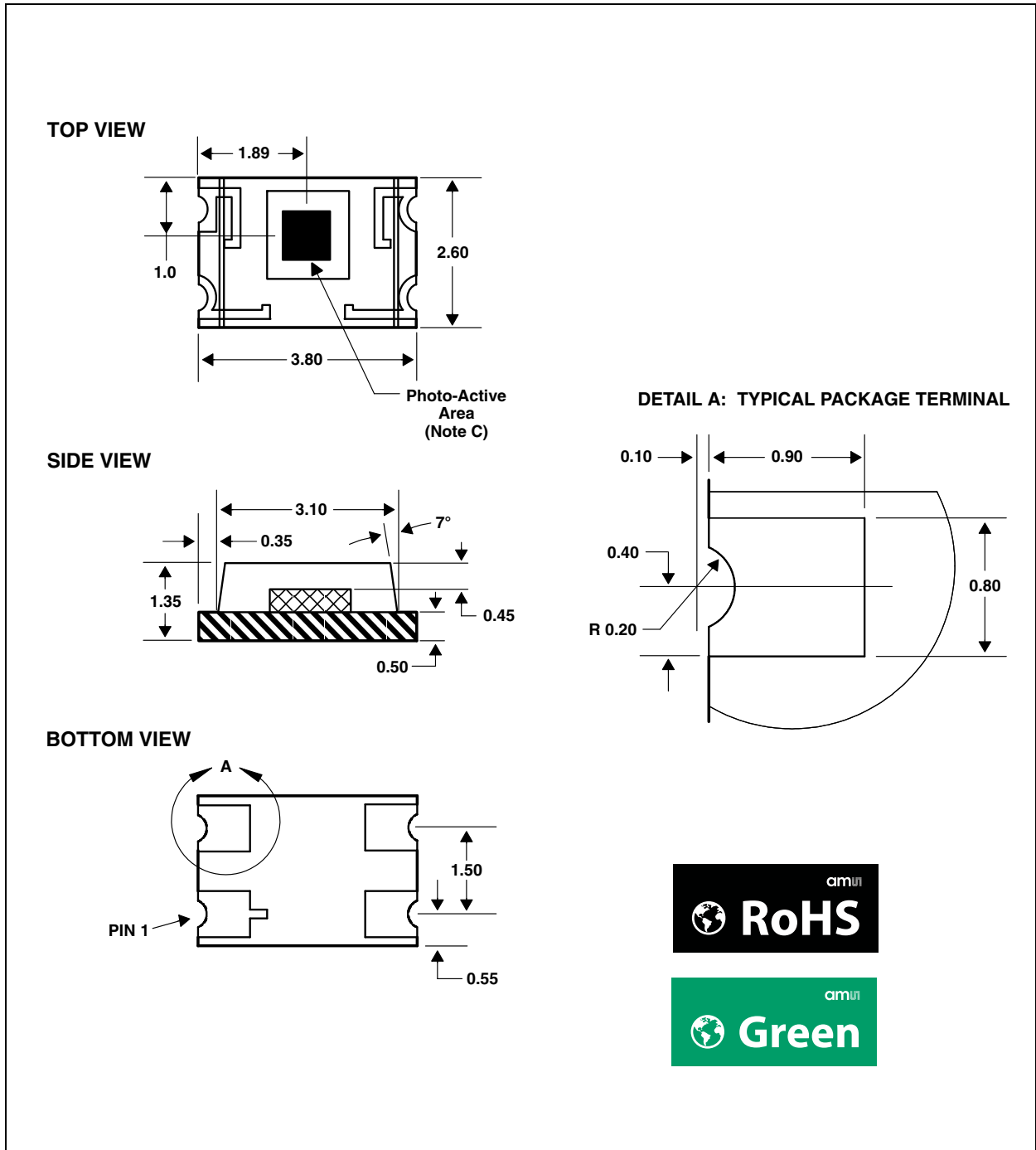

Note(s):

1. All linear dimensions are in millimeters.
2. Terminal finish is gold, 1.3µm minimum.
3. The center of the 0.84mm × 0.84mm integrated photodiode active area is referenced to the upper left corner of the package (near Pin 1).
4. Dimension tolerance is ±0.15mm.
5. This drawing is subject to change without notice.

Figure 20:
Package T - Four Lead Surface Mount Package Carrier Tape

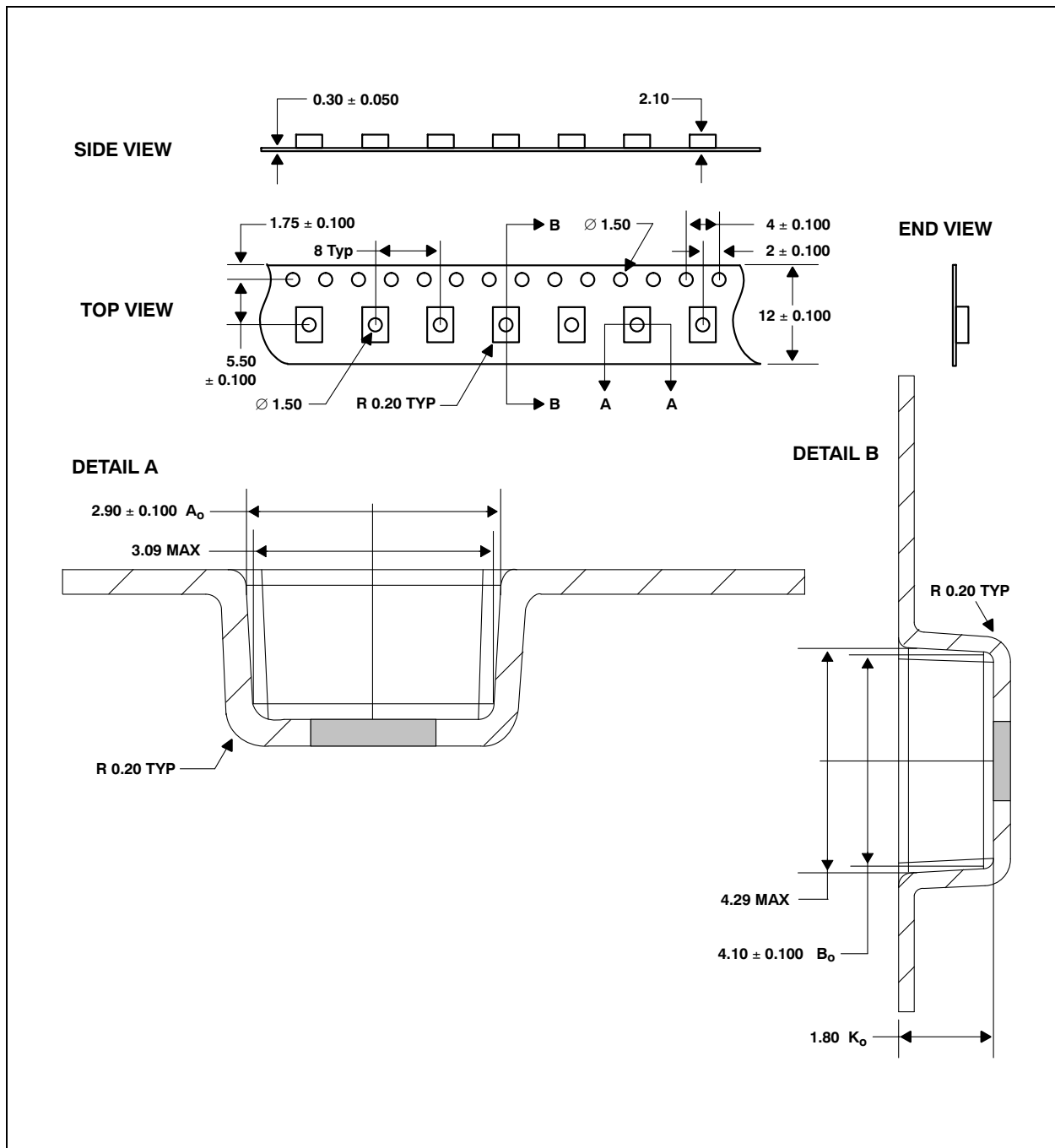

Note(s):

1. All linear dimensions are in millimeters.
2. The dimensions on this drawing are for illustrative purposes only. Dimensions of an actual carrier may vary slightly.
3. Symbols on drawing Ao, Bo, and Ko are defined in ANSI EIA Standard 481–B 2001.
4. Each reel is 178 millimeters in diameter and contains 1000 parts.
5. **ams** packaging tape and reel conform to the requirements of EIA Standard 481–B.
6. In accordance with EIA standard, device pin 1 is located next to the sprocket holes in the tape.
7. This drawing is subject to change without notice.

Manufacturing Information

The reflow profile specified here describes expected maximum heat exposure of devices during the solder reflow process of the device on a PWB. Temperature is measured at the top of the device. Devices should be limited to one pass through the solder reflow profile.

Figure 21:
TSL237 Solder Reflow Profile

Parameter	Reference	TSL237T
Average temperature gradient in preheating		2.5°C/s
Soak time	t_{soak}	2 to 3 minutes
Time above T_1 , 217°C	t_1	Max 60 s
Time above T_2 , 230°C	t_2	Max 50 s
Time above T_3 , ($T_{peak} - 10^\circ\text{C}$)	t_3	Max 10 s
Peak temperature in reflow	T_{peak}	260°C (-0°C/5°C)
Temperature gradient in cooling		Max -5°C/s

Figure 22:
Solder Reflow Profile

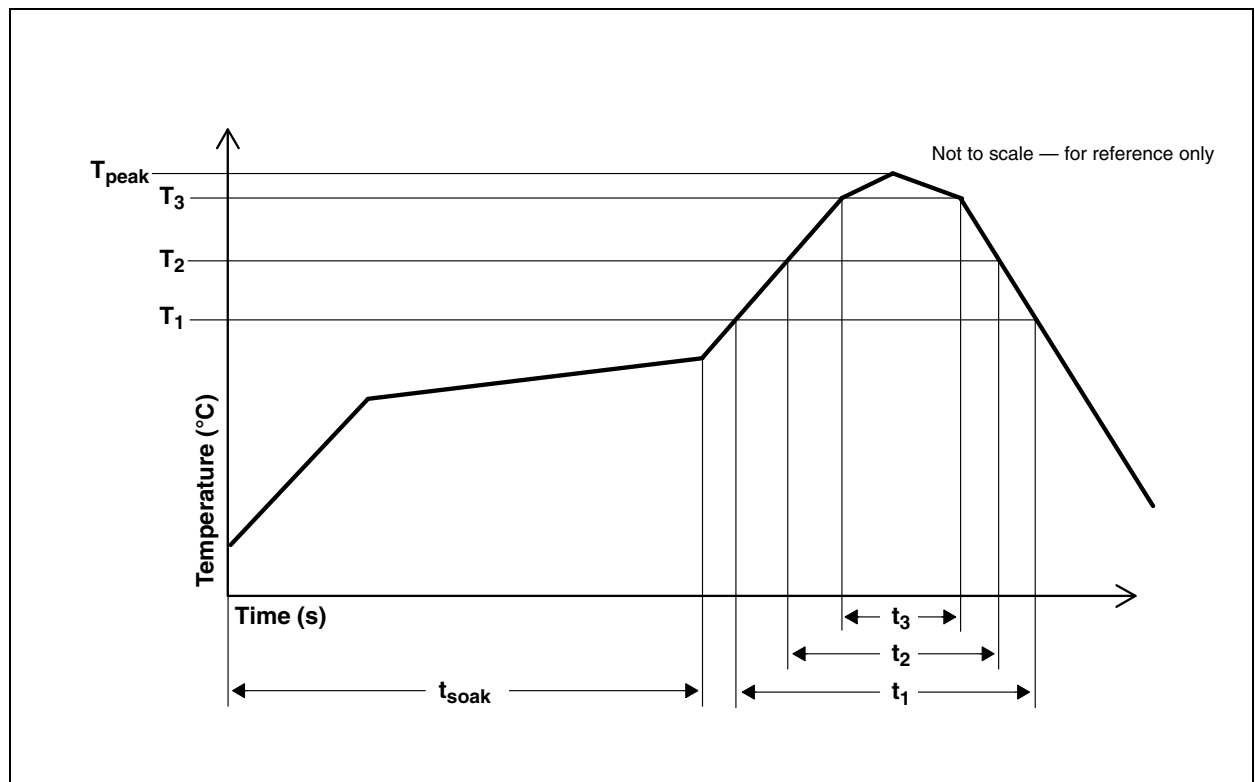

Moisture Sensitivity

Optical characteristics of the device can be adversely affected during the soldering process by the release and vaporization of moisture that has been previously absorbed into the package molding compound. To ensure the package molding compound contains the smallest amount of absorbed moisture possible, each device is dry-baked prior to being packed for shipping. Devices are packed in a sealed aluminized envelope with silica gel to protect them from ambient moisture during shipping, handling, and storage before use.

The T package have been assigned a moisture sensitivity level of MSL 3 and the devices should be stored under the following conditions:

- Temperature Range: 5°C to 50°C
- Relative Humidity: 60% maximum
- Total Time: 12 months from the date code on the aluminized envelope - if unopened
- Opened Time: 168 hours or fewer

Rebaking will be required if the devices have been stored unopened for more than 12 months or if the aluminized envelope has been open for more than 168 hours. If rebaking is required, it should be done at 50°C for 12 hours.

Ordering & Contact Information

Figure 23:
Ordering Information

Ordering Code	Device	T _A	Package - Leads	Package Designator
TSL237T	TSL237	-40°C to 85°C	4-lead Low Profile Surface Mount	T

Buy our products or get free samples online at:

www.ams.com/ICdirect

Technical Support is available at:

www.ams.com/Technical-Support

Provide feedback about this document at:

www.ams.com/Document-Feedback

For further information and requests, e-mail us at:

ams_sales@ams.com

For sales offices, distributors and representatives, please visit:

www.ams.com/contact

Headquarters

ams AG

Tobelbader Strasse 30

8141 Premstaetten

Austria, Europe

Tel: +43 (0) 3136 500 0

Website: www.ams.com

RoHS Compliant & ams Green Statement

RoHS: The term RoHS compliant means that ams AG products fully comply with current RoHS directives. Our semiconductor products do not contain any chemicals for all 6 substance categories, including the requirement that lead not exceed 0.1% by weight in homogeneous materials. Where designed to be soldered at high temperatures, RoHS compliant products are suitable for use in specified lead-free processes.

ams Green (RoHS compliant and no Sb/Br): ams Green defines that in addition to RoHS compliance, our products are free of Bromine (Br) and Antimony (Sb) based flame retardants (Br or Sb do not exceed 0.1% by weight in homogeneous material).

Important Information: The information provided in this statement represents ams AG knowledge and belief as of the date that it is provided. ams AG bases its knowledge and belief on information provided by third parties, and makes no representation or warranty as to the accuracy of such information. Efforts are underway to better integrate information from third parties. ams AG has taken and continues to take reasonable steps to provide representative and accurate information but may not have conducted destructive testing or chemical analysis on incoming materials and chemicals. ams AG and ams AG suppliers consider certain information to be proprietary, and thus CAS numbers and other limited information may not be available for release.

Copyrights & Disclaimer

Copyright ams AG, Tobelbader Strasse 30, 8141 Premstaetten, Austria-Europe. Trademarks Registered. All rights reserved. The material herein may not be reproduced, adapted, merged, translated, stored, or used without the prior written consent of the copyright owner.

Devices sold by ams AG are covered by the warranty and patent indemnification provisions appearing in its General Terms of Trade. ams AG makes no warranty, express, statutory, implied, or by description regarding the information set forth herein. ams AG reserves the right to change specifications and prices at any time and without notice. Therefore, prior to designing this product into a system, it is necessary to check with ams AG for current information. This product is intended for use in commercial applications. Applications requiring extended temperature range, unusual environmental requirements, or high reliability applications, such as military, medical life-support or life-sustaining equipment are specifically not recommended without additional processing by ams AG for each application. This product is provided by ams AG "AS IS" and any express or implied warranties, including, but not limited to the implied warranties of merchantability and fitness for a particular purpose are disclaimed.

ams AG shall not be liable to recipient or any third party for any damages, including but not limited to personal injury, property damage, loss of profits, loss of use, interruption of business or indirect, special, incidental or consequential damages, of any kind, in connection with or arising out of the furnishing, performance or use of the technical data herein. No obligation or liability to recipient or any third party shall arise or flow out of ams AG rendering of technical or other services.

Document Status

Document Status	Product Status	Definition
Product Preview	Pre-Development	Information in this datasheet is based on product ideas in the planning phase of development. All specifications are design goals without any warranty and are subject to change without notice
Preliminary Datasheet	Pre-Production	Information in this datasheet is based on products in the design, validation or qualification phase of development. The performance and parameters shown in this document are preliminary without any warranty and are subject to change without notice
Datasheet	Production	Information in this datasheet is based on products in ramp-up to full production or full production which conform to specifications in accordance with the terms of ams AG standard warranty as given in the General Terms of Trade
Datasheet (discontinued)	Discontinued	Information in this datasheet is based on products which conform to specifications in accordance with the terms of ams AG standard warranty as given in the General Terms of Trade, but these products have been superseded and should not be used for new designs

Revision Information

Changes from 1-00 (2016-Aug-22) to current revision 1-01 (2018-Apr-04)	Page
Removed all instances of TSL237CL and respective data	

Note(s):

1. Page and figure numbers for the previous version may differ from page and figure numbers in the current revision.
2. Correction of typographical errors is not explicitly mentioned

Content Guide

- 1 General Description**
 - 1 Key Benefits & Features
 - 2 Block Diagram

- 3 Pin Assignments**
- 4 Absolute Maximum Ratings**
- 5 Electrical Characteristics**
- 7 Typical Operating Characteristics**

- 11 Application Information**
 - 11 Power-Supply Considerations
 - 11 Device Operational Details
 - 12 Input Interface
 - 12 Output Interface
 - 12 Measuring the Frequency
 - 13 PCB Pad Layout

- 14 Packaging Mechanical Data**

- 16 Manufacturing Information**
 - 17 Moisture Sensitivity

- 18 Ordering & Contact Information**
- 19 RoHS Compliant & ams Green Statement**
- 20 Copyrights & Disclaimer**
- 21 Document Status**
- 22 Revision Information**