

SAW Filter 915.0MHz
Part No: MA04499

Model: TA0281A
Rev No: 6

A. MAXIMUM RATING:

Electrostatic Sensitive Device

1. Input Power Level: 15dBm
2. DC voltage: 5V
3. Operating Temperature: -40°C to +85°C
4. Storage Temperature: -40°C to +85°C
5. Moisture Sensitivity Level: Level 1 (MSL1)

B. ELECTRICAL CHARACTERISTICS:

Item	Unit	Min.	Typ.	Max.
Center frequency Fc	MHz	-	915	-
Insertion loss 902 ~ 928MHz IL	dB	-	2.2	3.5
Amplitude ripple 902 ~ 928MHz	dB	-	0.6	2.0
VSWR 902 ~ 928MHz	-	-	1.6	2.3
Attenuation (Reference level from 0dB)				
D.C. ~ 800MHz	dB	50	63	-
800 ~ 880MHz	dB	40	48	-
960 ~ 1080MHz	dB	32	39	-
1080 ~ 1500MHz	dB	45	65	-
1500 ~ 3000MHz	dB	22	28	-
Source impedance Z _S	Ω	-	50	-
Load impedance Z _L	Ω	-	50	-

SAW Filter 915.0MHz
Part No: MA04499

Model: TA0281A
Rev No: 6

C. MEASUREMENT CIRCUIT:

HP Network analyzer

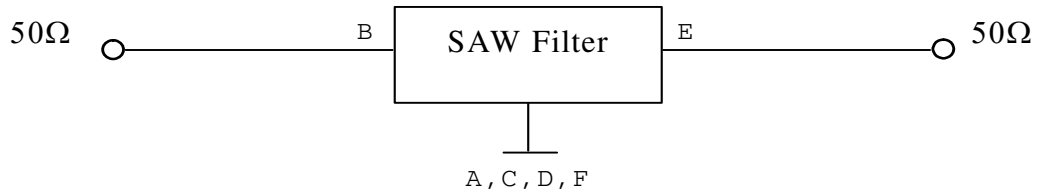

D. OUTLINE DRAWING:

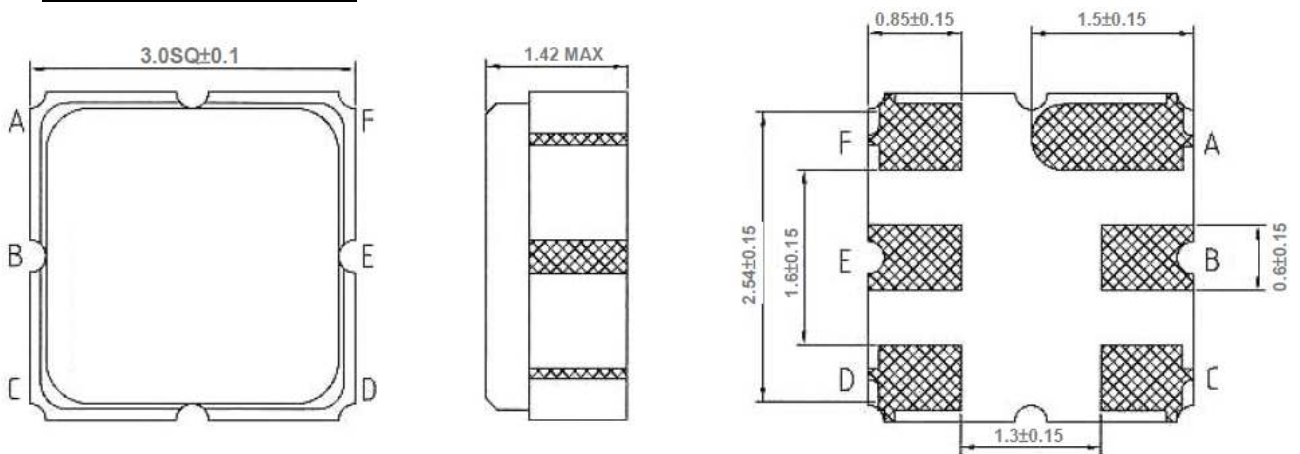

B: Input
 E: Output
 A, C, D, F: Ground
 Unit: mm

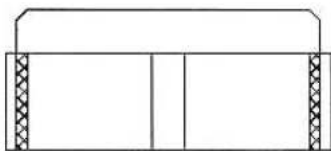

E. PCB FOOTPRINT:

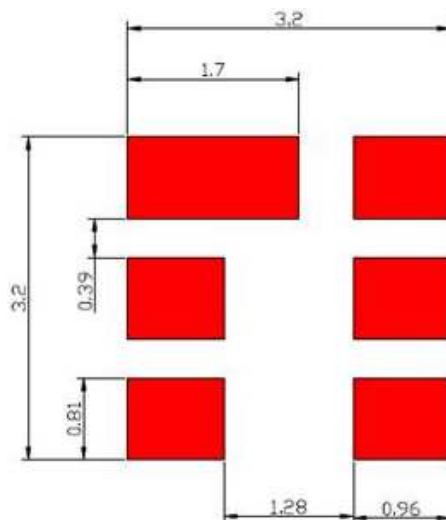

SAW Filter 915.0MHz
Part No: MA04499

Model: TA0281A
Rev No: 6

F. FREQUENCY CHARACTERISTICS:

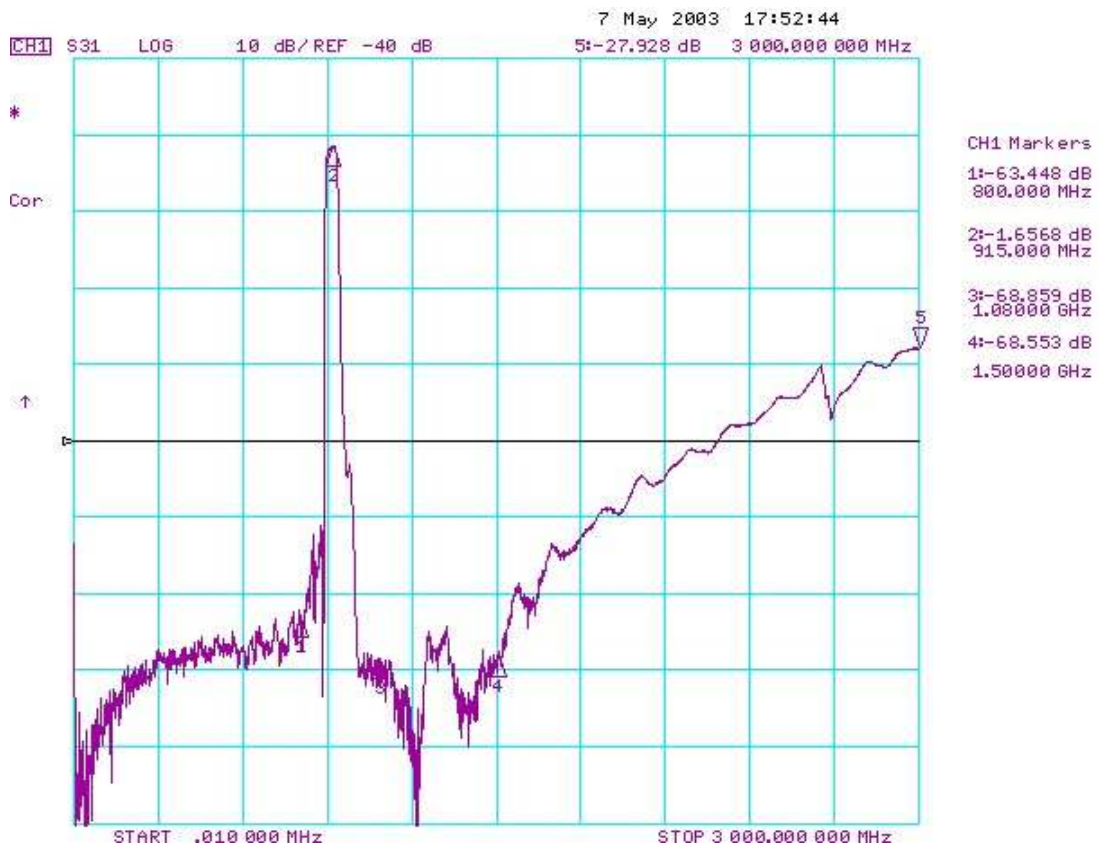
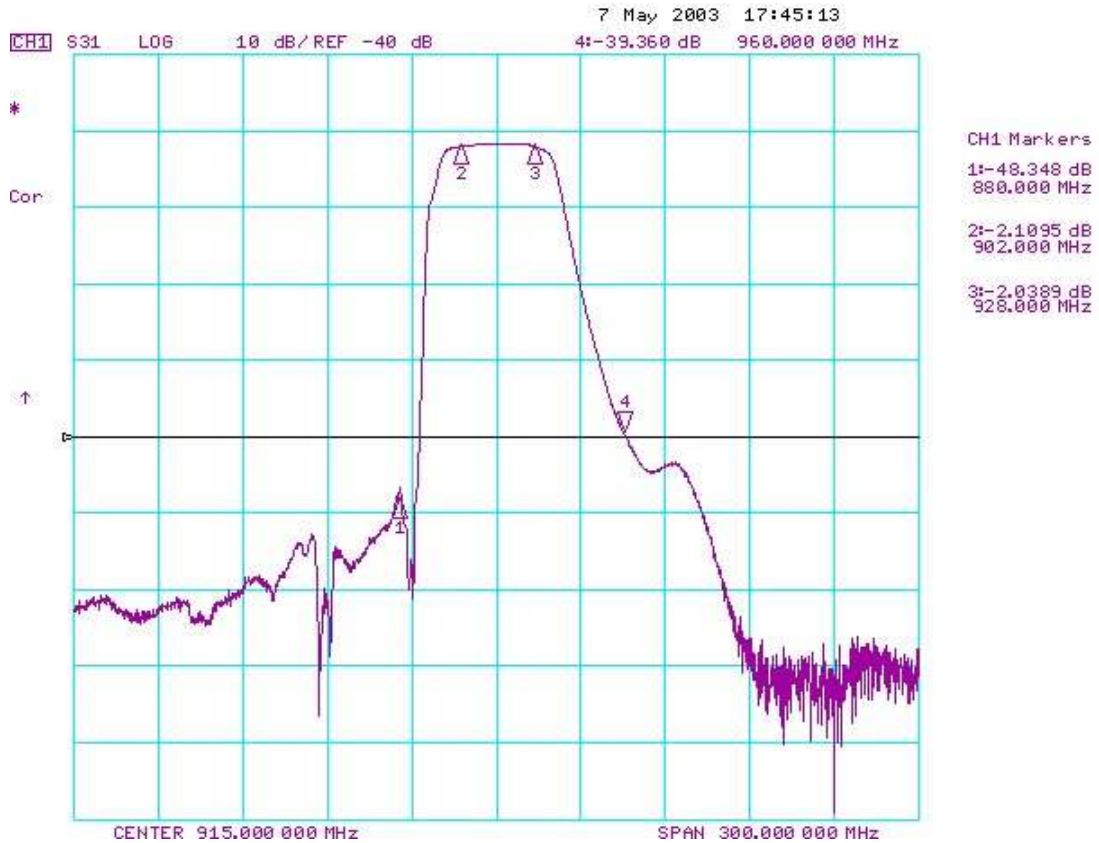

SAW Filter 915.0MHz
Part No: MA04499

Model: TA0281A
Rev No: 6

Reflections Functions

S11

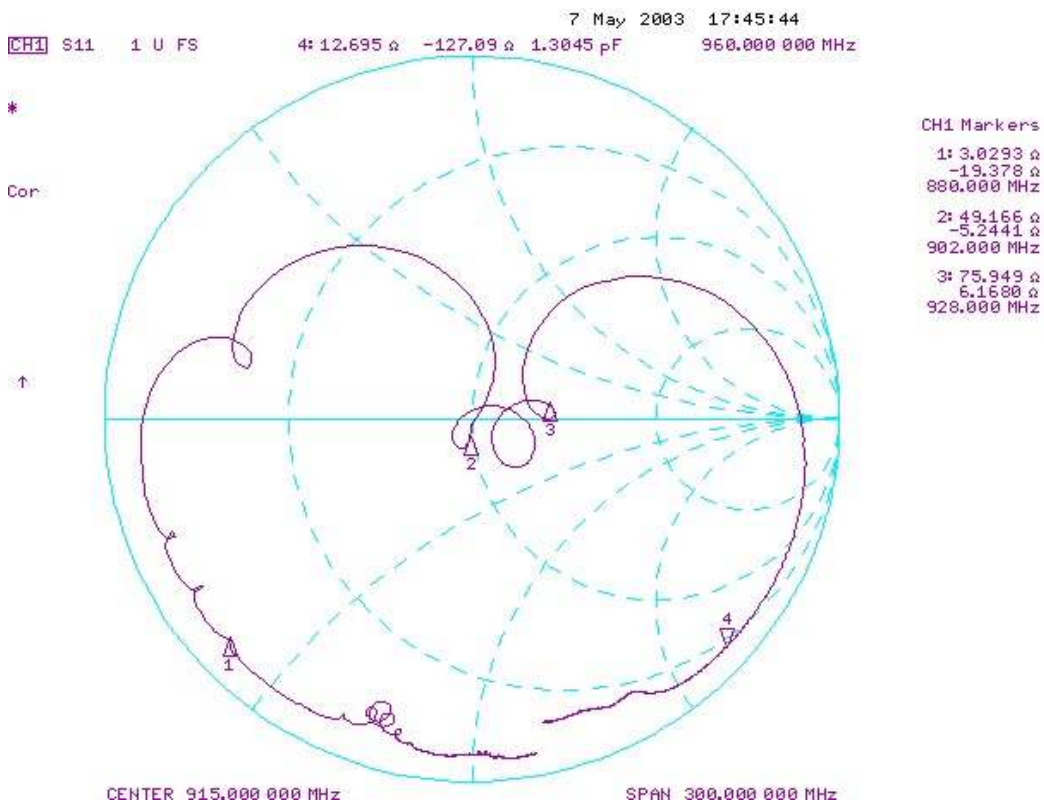

SAW Filter 915.0MHz
Part No: MA04499

Model: TA0281A
Rev No: 6

S22

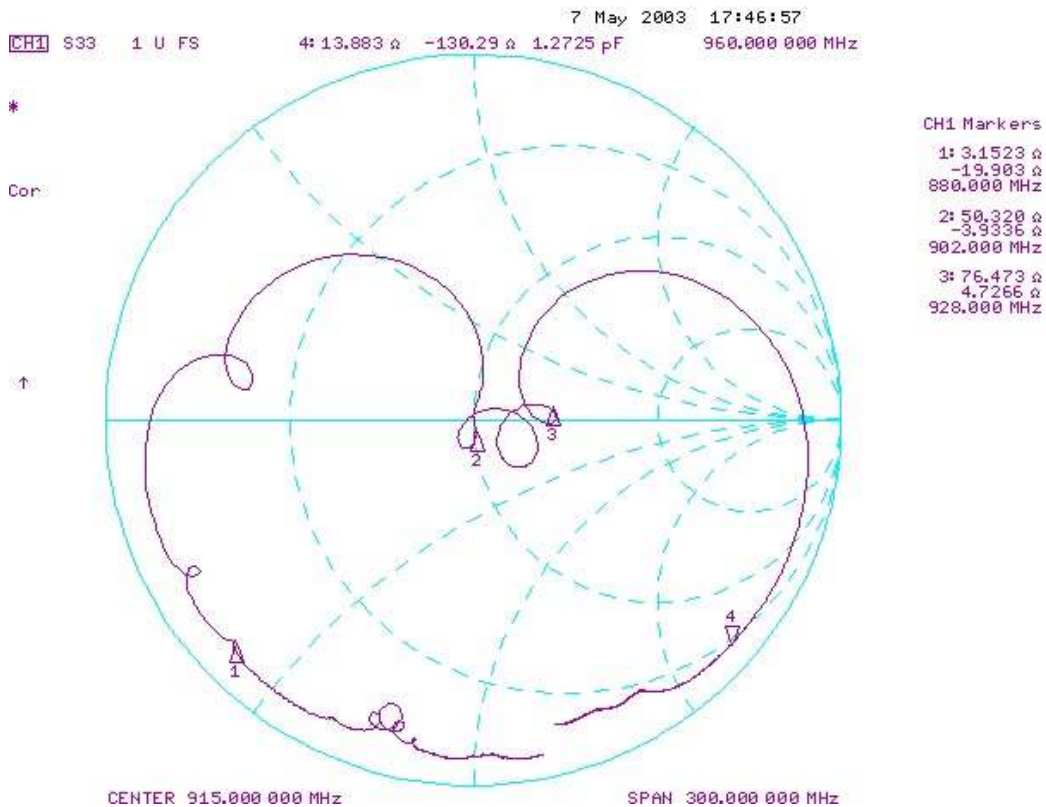

SAW Filter 915.0MHz
Part No: MA04499

Model: TA0281A
Rev No: 6

G. PACKING:

1. Reel Dimension

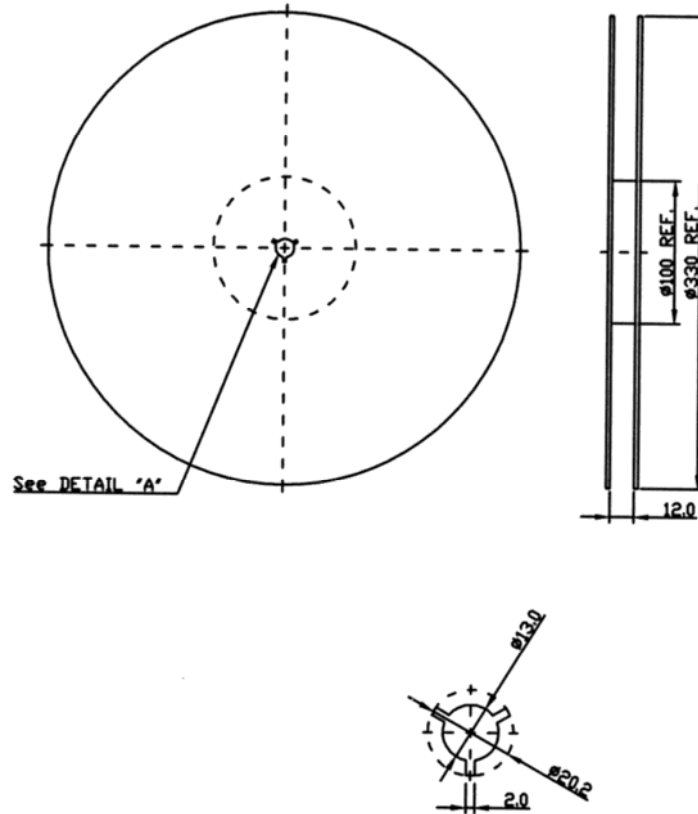

2. Tape Dimension

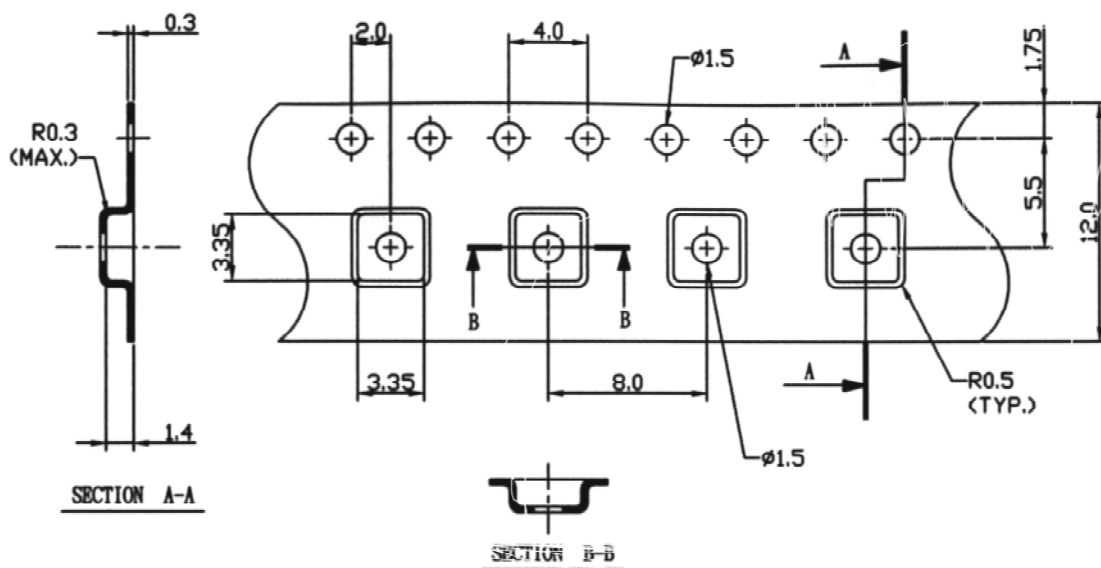

SAW Filter 915.0MHz
Part No: MA04499

Model: TA0281A
Rev No: 6

H. RECOMMENDED REFLOW PROFILE:

1. Preheating shall be fixed at 150 ~ 180°C for 60 ~ 90 seconds.
2. Ascending time to preheating temperature 150°C shall be 30 seconds min.
3. Heating shall be fixed at 220°C for 50 ~ 80 seconds and at 260°C +0/-5°C peak (20 ~ 40 sec).
4. Time: 2 times.

