

## 2.7Gbps, Low-Power SFP Laser Drivers

## General Description

The MAX3735/MAX3735A are +3.3V laser drivers for SFP/SFF applications from 155Mbps up to 2.7Gbps. The devices accept differential input data and provide bias and modulation currents for driving a laser. DC-coupling to the laser allows for multirate applications and reduces the number of external components. The MAX3735/MAX3735A are fully compliant with the SFP MSA timing and the SFF-8472 transmit diagnostic requirements.

An automatic power-control (APC) feedback loop is incorporated to maintain a constant average optical power over temperature and lifetime. The wide modulation current range of 10mA to 60mA (up to 85mA AC-coupled) and bias current of 1mA to 100mA make this product ideal for driving FP/DFB laser diodes in fiber-optic modules. The resistor range for the laser current settings is optimized to interface with the DS1858 SFP controller IC.

The MAX3735/MAX3735A provide transmit-disable control, a single-point latched transmit-failure monitor output, photocurrent monitoring, and bias-current monitoring to indicate when the APC loop is unable to maintain the average optical power. The MAX3735A also features improved multirate operation.

The MAX3735/MAX3735A come in package and die form, and operate over the extended temperature range of -40°C to +85°C.

## Applications

Gigabit Ethernet SFP/SFF Transceiver Modules  
1G/2G Fibre Channel SFP/SFF Transceiver Modules  
Multirate OC3 to OC48-FEC SFP/SFF Transceiver Modules

## Features

- ◆ SFP Reference Design Available
- ◆ Fully Compliant with SFP and SFF-8472 MSAs
- ◆ Programmable Modulation Current from 10mA to 60mA (DC-Coupled)
- ◆ Programmable Modulation Current from 10mA to 85mA (AC-Coupled)
- ◆ Programmable Bias Current from 1mA to 100mA
- ◆ Edge Transition Times <51ps
- ◆ 27mA (typ) Power-Supply Current
- ◆ Multirate 155Mbps to 2.7Gbps Operation
- ◆ Automatic Average Power Control
- ◆ On-Chip Pullup Resistor for TX\_DISABLE
- ◆ 24-Pin 4mm × 4mm QFN package

## Ordering Information

PART	TEMP RANGE	PIN-PACKAGE
MAX3735E/D	-40°C to +85°C	Dice*
MAX3735ETG	-40°C to +85°C	24 Thin QFN-EP**
MAX3735EGG	-40°C to +85°C	24 QFN-EP**
MAX3735AETG	-40°C to +85°C	24 Thin QFN-EP**
MAX3735AETG+	-40°C to +85°C	24 Thin QFN-EP**

\*Dice are designed to operate from -40°C to +85°C, but are tested and guaranteed only at  $T_A = +25^\circ\text{C}$ .

\*\*EP = Exposed pad.

+Denotes lead-free package.

Pin Configuration appears at end of data sheet.

## Typical Application Circuit

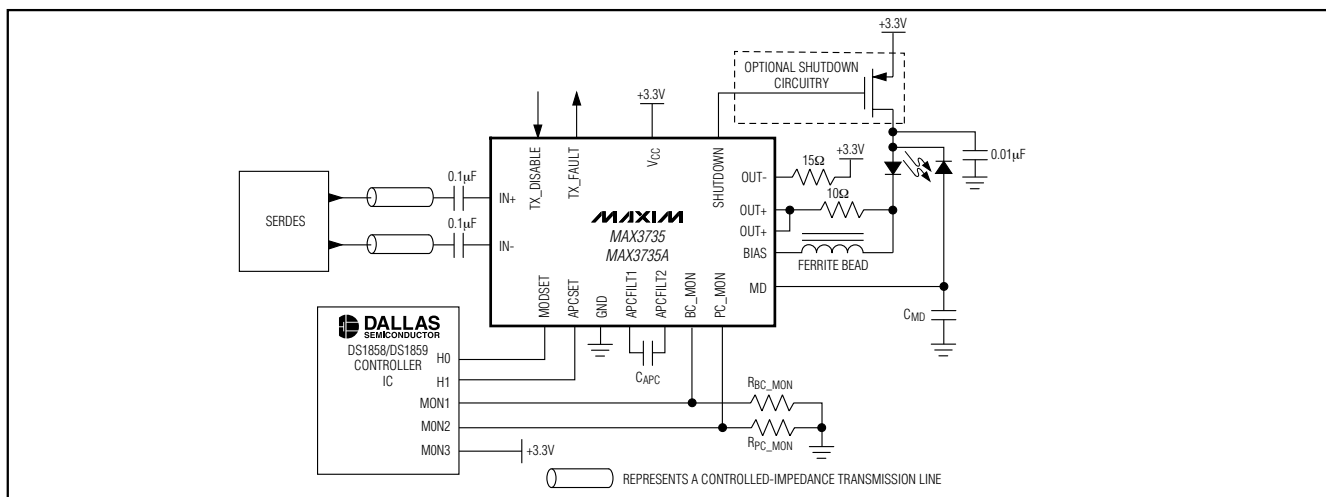

## 2.7Gbps, Low-Power SFP Laser Drivers

### ABSOLUTE MAXIMUM RATINGS

Supply Voltage, $V_{CC}$ .....	-0.5V to +6.0V	Continuous Power Dissipation ( $T_A = +85^\circ\text{C}$ )	
Current into BIAS, OUT+, OUT- .....	-20mA to +150mA	24-Lead Thin QFN (derate 20.8mW/ $^\circ\text{C}$ )	
Current into MD.....	-5mA to +5mA	above +85 $^\circ\text{C}$ ).....	1354mW
Voltage at IN+, IN-, TX_DISABLE, TX_FAULT, SHUTDOWN .....	-0.5V to ( $V_{CC} + 0.5\text{V}$ )	24-Lead QFN (derate 20.8mW/ $^\circ\text{C}$ )	
Voltage at IN+, IN-, TX_DISABLE, TX_FAULT, SHUTDOWN .....	-0.5V to ( $V_{CC} + 0.5\text{V}$ )	above +85 $^\circ\text{C}$ ).....	1354mW
Voltage at BIAS, PC_MON, BC_MON, MODSET, APCSET .....	-0.5V to ( $V_{CC} + 0.5\text{V}$ )	Operating Ambient Temperature Range ( $T_A$ ).....	-40 $^\circ\text{C}$ to +85 $^\circ\text{C}$
Voltage at OUT+, OUT-.....	+0.5V to ( $V_{CC} + 1.5\text{V}$ )	Storage Ambient Temperature Range.....	-55 $^\circ\text{C}$ to +150 $^\circ\text{C}$
Voltage at APCFLT1, APCFLT2.....	-0.5V to +3V	Die Attach Temperature.....	+400 $^\circ\text{C}$
		Lead Temperature (soldering, 10s).....	+300 $^\circ\text{C}$

Stresses beyond those listed under "Absolute Maximum Ratings" may cause permanent damage to the device. These are stress ratings only, and functional operation of the device at these or any other conditions beyond those indicated in the operational sections of the specifications is not implied. Exposure to absolute maximum rating conditions for extended periods may affect device reliability.

### ELECTRICAL CHARACTERISTICS

( $V_{CC} = +2.97\text{V}$  to +3.63V,  $T_A = -40^\circ\text{C}$  to +85 $^\circ\text{C}$ . Typical values at  $V_{CC} = +3.3\text{V}$ ,  $I_{BIAS} = 20\text{mA}$ ,  $I_{MOD} = 30\text{mA}$ ,  $T_A = +25^\circ\text{C}$ , unless otherwise noted.) (Note 1)

PARAMETER	SYMBOL	CONDITIONS	MIN	TYP	MAX	UNITS
<b>POWER SUPPLY</b>						
Power-Supply Current	$I_{CC}$	Excludes the laser bias and modulation currents (Note 2)		27	50	mA
<b>I/O SPECIFICATIONS</b>						
Differential Input Voltage	$V_{ID}$	$V_{ID} = (V_{IN+}) - (V_{IN-})$ , Figure 1	200		2400	mV <sub>P-P</sub>
Common-Mode Input Voltage				$0.6 \times V_{CC}$		V
Differential Input Resistance			85	100	115	$\Omega$
TX_DISABLE Input Pullup Resistance	$R_{PULL}$		4.7	7.4	10.0	k $\Omega$
TX_DISABLE Input Current		$V_{HIGH} = V_{CC}$ $V_{LOW} = \text{GND}$ , $V_{CC} = 3.3\text{V}$ , $R_{PULL} = 7.4\text{k}\Omega$			15	$\mu\text{A}$
TX_DISABLE Input High Voltage	$V_{IH}$		2			V
TX_DISABLE Input Low Voltage	$V_{IL}$				0.8	V
TX_FAULT Output High Voltage	$V_{OH}$	$I_{OH} = 100\mu\text{A}$ sourcing (Note 3)	2.4			V
TX_FAULT Output Low Voltage	$V_{OL}$	$I_{OL} = 1\text{mA}$ sinking (Note 3)			0.4	V
SHUTDOWN Output High Voltage	$V_{OH}$	$I_{OH} = 100\mu\text{A}$ sourcing	$V_{CC} - 0.4$			V
SHUTDOWN Output Low Voltage	$V_{OL}$	$I_{OL} = 100\mu\text{A}$ sinking			0.4	V
<b>BIAS GENERATOR</b>						
Bias On-Current Range	$I_{BIAS}$	Current into BIAS pin	1		100	mA
Bias Off-Current	$I_{BIASOFF}$	Current into BIAS pin during TX_FAULT or TX_DISABLE			100	$\mu\text{A}$
Bias Overshoot		During SFP module hot plugging (Notes 4, 5, 11)			10	%
Bias-Current Monitor Gain	$I_{BC\_MON}$	External resistor to GND defines the voltage gain, $I_{BIAS} = 1\text{mA}$ , $R_{BC\_MON} = 69.28\text{k}\Omega$	10.0	12	13.5	mA/A
		$I_{BIAS} = 100\text{mA}$ , $R_{BC\_MON} = 693.25\Omega$	11.5	13	13.5	
Bias-Current Monitor Gain Stability		$1\text{mA} \leq I_{BIAS} \leq 100\text{mA}$ (Notes 4, 6)				%
		MAX3735	-8		+8	
		MAX3735A	-6		+6	

# 2.7Gbps, Low-Power SFP Laser Drivers

MAX3735/MAX3735A

## ELECTRICAL CHARACTERISTICS (continued)

(V<sub>CC</sub> = +2.97V to +3.63V, T<sub>A</sub> = -40°C to +85°C. Typical values at V<sub>CC</sub> = +3.3V, I<sub>BIAS</sub> = 20mA, I<sub>MOD</sub> = 30mA, T<sub>A</sub> = +25°C, unless otherwise noted.) (Note 1)

PARAMETER	SYMBOL	CONDITIONS	MIN	TYP	MAX	UNITS	
<b>AUTOMATIC POWER-CONTROL LOOP</b>							
MD Reverse Bias Voltage		18μA ≤ I <sub>MD</sub> ≤ 1500μA	1.6			V	
MD Average Current Range	I <sub>MD</sub>	Average current into MD pin	18		1500	μA	
Average Power-Setting Stability		APC closed loop (Notes 4, 7)	I <sub>BIAS</sub> = 1mA (MAX3735)	-880	+880	ppm/°C	
			I <sub>BIAS</sub> = 1mA (MAX3735A)	-110	+110		
			I <sub>BIAS</sub> = 100mA	-650	+650		
Average Power Setting Accuracy		APC Closed Loop 1mA ≤ I <sub>BIAS</sub> ≤ 100mA (Note 8)	-16		+16	%	
MD-Current Monitor Gain	I <sub>PC_MON</sub>	External resistor to GND defines the voltage gain; I <sub>MD</sub> = 18μA, R <sub>PC_MON</sub> = 50kΩ	MAX3735	0.8	1	1.23	A/A
			MAX3735A	0.9		1.1	
			I <sub>MD</sub> = 1.5mA, R <sub>PC_MON</sub> = 600Ω	0.95	1	1.05	
MD-Current Monitor Gain Stability		18μA ≤ I <sub>MD</sub> ≤ 1500μA (Notes 4, 6)	MAX3735	-10		+10	%
			MAX3735A	-4		+4	
<b>LASER MODULATOR</b>							
Modulation On-Current Range	I <sub>MOD</sub>	Current into OUT+ pin; R <sub>L</sub> ≤ 15Ω, V <sub>OUT+</sub> , V <sub>OUT-</sub> ≥ 0.6V (DC-coupled)	10		60	mA	
		Current into OUT+ pin; R <sub>L</sub> ≤ 15Ω, V <sub>OUT+</sub> , V <sub>OUT-</sub> ≥ 2.0V (AC-coupled)	10		85		
Modulation Off-Current	I <sub>MODOFF</sub>	Current into OUT+ pin during TX_FAULT or TX_DISABLE			100	μA	
Modulation-Current Stability (Note 4)		I <sub>MOD</sub> = 10mA	-480		+480	ppm/°C	
		I <sub>MOD</sub> = 60mA	-255		+255		
Modulation-Current Absolute Accuracy		10mA ≤ I <sub>MOD</sub> ≤ 60mA (Note 8)	-15		+15	%	
Modulation-Current Rise Time	t <sub>R</sub>	20% to 80%, 10mA ≤ I <sub>MOD</sub> ≤ 60mA (Note 4)		42	65	ps	
Modulation-Current Fall Time	t <sub>F</sub>	20% to 80%, 10mA ≤ I <sub>MOD</sub> ≤ 60mA (Note 4)		50	80	ps	
Deterministic Jitter		10mA ≤ I <sub>MOD</sub> ≤ 60mA at 2.67Gbps (Notes 4, 9, 10)		18	38	ps	
		At 1.25Gbps (K28.5 pattern)		11.5			
		At 622Mbps (Note 9)		18			
		At 155Mbps (Note 9)		40			
Random Jitter	RJ	10mA ≤ I <sub>MOD</sub> ≤ 60mA (Note 4)		0.7	1.0	psRMS	

## 2.7Gbps, Low-Power SFP Laser Drivers

### ELECTRICAL CHARACTERISTICS (continued)

(V<sub>CC</sub> = +2.97V to +3.63V, T<sub>A</sub> = -40°C to +85°C. Typical values at V<sub>CC</sub> = +3.3V, I<sub>BIAS</sub> = 20mA, I<sub>MOD</sub> = 30mA, T<sub>A</sub> = +25°C, unless otherwise noted.) (Note 1)

PARAMETER	SYMBOL	CONDITIONS	MIN	TYP	MAX	UNITS
<b>SAFETY FEATURES</b>						
Excessive Bias-Current Comparator Threshold Range		TX_FAULT always occurs for V <sub>BC_MON</sub> ≥ 1.38V, TX_FAULT never occurs for V <sub>BC_MON</sub> ≤ 1.22V	1.22	1.30	1.39	V
Excessive MD-Current Comparator Threshold Range		TX_FAULT always occurs for V <sub>PC_MON</sub> ≥ 1.38V, TX_FAULT never occurs for V <sub>PC_MON</sub> ≤ 1.22V	1.22	1.30	1.39	V
<b>SFP TIMING REQUIREMENTS</b>						
TX_DISABLE Assert Time	t <sub>off</sub>	Time from rising edge of TX_DISABLE to I <sub>BIAS</sub> = I <sub>BIASOFF</sub> and I <sub>MOD</sub> = I <sub>MODOFF</sub> (Note 4)		0.14	5	μs
TX_DISABLE Negate Time	t <sub>on</sub>	Time from falling edge of TX_DISABLE to I <sub>BIAS</sub> and I <sub>MOD</sub> at 95% of steady state when TX_FAULT = 0 before reset			1	ms
		C <sub>APC</sub> = 2.7nF, MAX3735 (Note 4) MAX3735A (Note 11)			600	μs
TX_DISABLE Negate Time During FAULT Recovery	t <sub>onFAULT</sub>	Time from falling edge of TX_DISABLE to I <sub>BIAS</sub> and I <sub>MOD</sub> at 95% of steady state when TX_FAULT = 1 before reset (Note 4)		60	200	ms
TX_FAULT Reset Time or Power-On Time	t <sub>init</sub>	From power-on or negation of TX_FAULT using TX_DISABLE (Note 4)		60	200	ms
TX_FAULT Assert Time	t <sub>fault</sub>	Time from fault to TX_FAULT on, C <sub>FAULT</sub> ≤ 20pF, R <sub>FAULT</sub> = 4.7kΩ (Note 4)		3.3	50	μs
TX_DISABLE to Reset		Time TX_DISABLE must be held high to reset TX_FAULT (Note 4)			5	μs

**Note 1:** Specifications at -40°C are guaranteed by design and characterization. Dice are tested at T<sub>A</sub> = +25°C only.

**Note 2:** Maximum value is specified at I<sub>MOD</sub> = 60mA, I<sub>BIAS</sub> = 100mA.

**Note 3:** TX\_FAULT is an open-collector output and must be pulled up with a 4.7kΩ to 10kΩ resistor.

**Note 4:** Guaranteed by design and characterization.

**Note 5:** V<sub>CC</sub> turn-on time must be ≤ 0.8s, DC-coupled interface.

**Note 6:** Gain stability is defined by the digital diagnostic document (SFF-8472, rev. 9.0) over temperature and supply variation.

**Note 7:** Assuming that the laser diode to photodiode transfer function does not change with temperature.

**Note 8:** Accuracy refers to part-to-part variation.

**Note 9:** Deterministic jitter is measured using a 223 - 1 PRBS or equivalent pattern.

**Note 10:** Broadband noise is filtered through the network as shown in Figure 3. One capacitor, C < 0.47μF, and one 0603 ferrite bead or inductor can be added (optional). This supply voltage filtering reduces the hot-plugging inrush current. The supply noise must be < 100mV<sub>P-P</sub> up to 2MHz.

**Note 11:** C<sub>APC</sub> values chosen as shown in Table 4 (MAX3735A).

# 2.7Gbps, Low-Power SFP Laser Drivers

**MAX3735/MAX3735A**

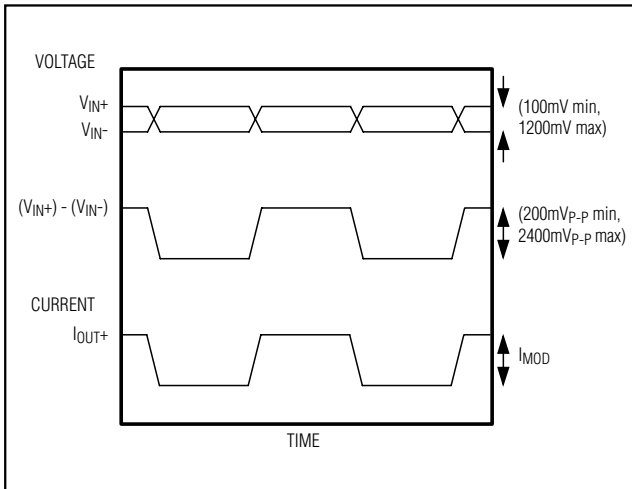

Figure 1. Required Input Signal and Output Polarity

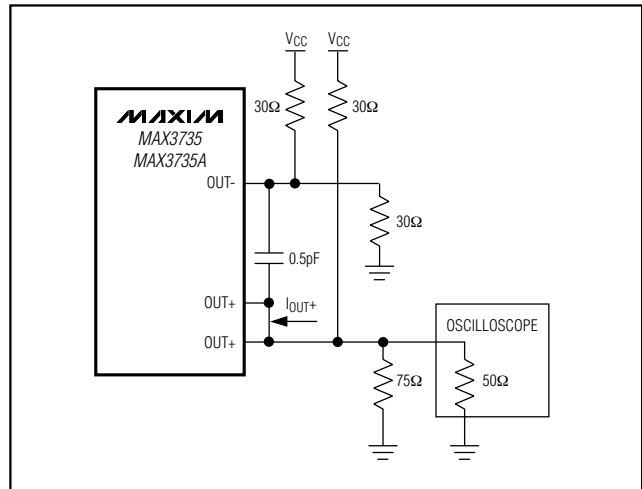

Figure 2. Output Termination for Characterization

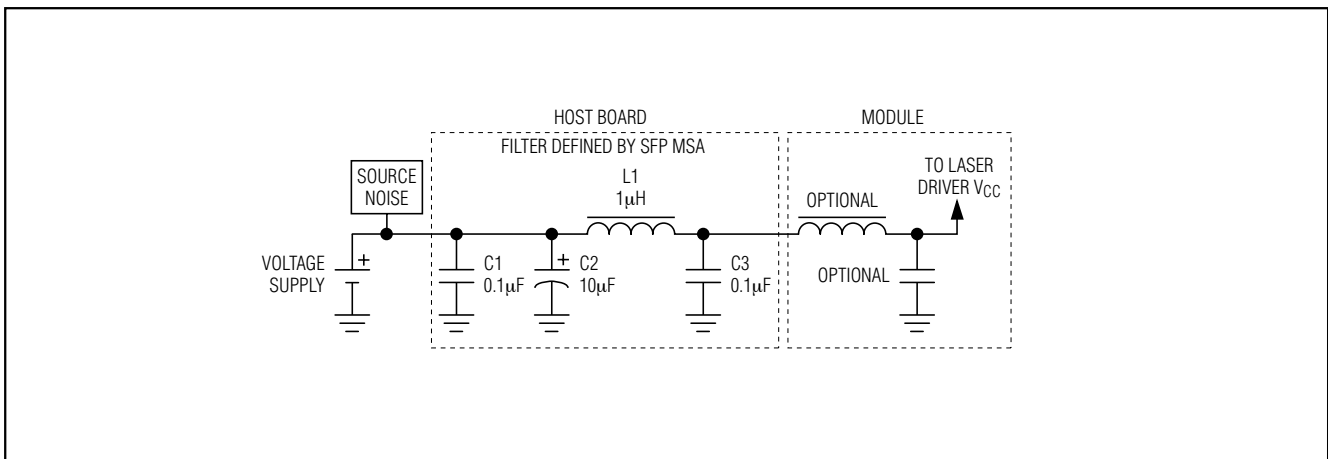

Figure 3. Supply Filter

# 2.7Gbps, Low-Power SFP Laser Drivers

## Typical Operating Characteristics

( $V_{CC} = +3.3V$ ,  $C_{APC} = 0.01\mu F$ ,  $I_{BIAS} = 20mA$ , and  $I_{MOD} = 30mA$ ,  $T_A = +25^\circ C$ , unless otherwise noted.)

**OPTICAL EYE**

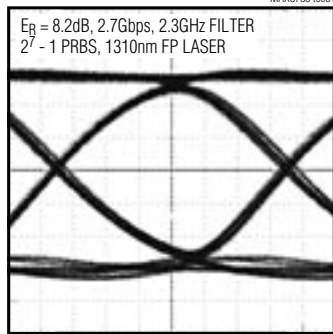

54ps/div

**OPTICAL EYE**

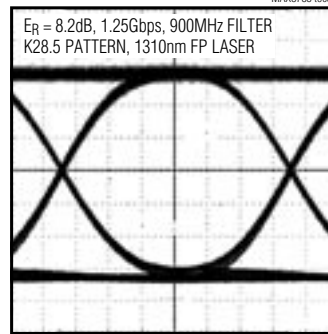

115ps/div

**OPTICAL EYE**

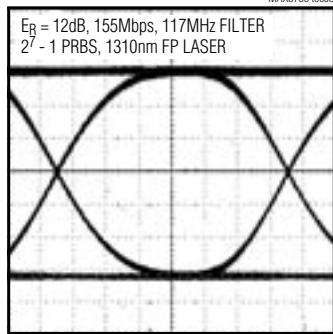

919ps/div

**ELECTRICAL EYE**

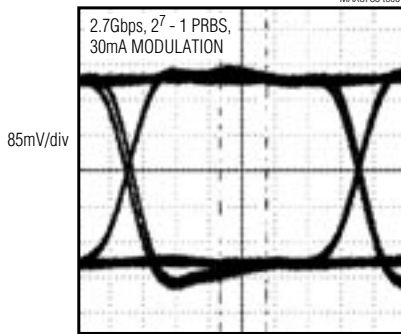

85mV/div

58ps/div

**SUPPLY CURRENT vs. TEMPERATURE**

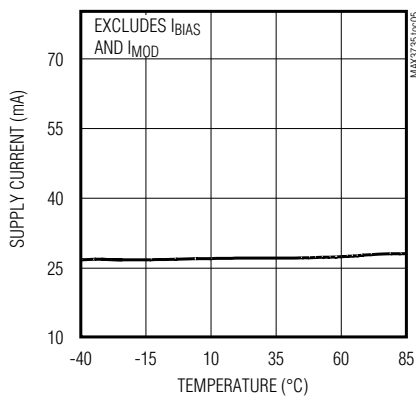

**BIAS-CURRENT MONITOR GAIN vs. TEMPERATURE**

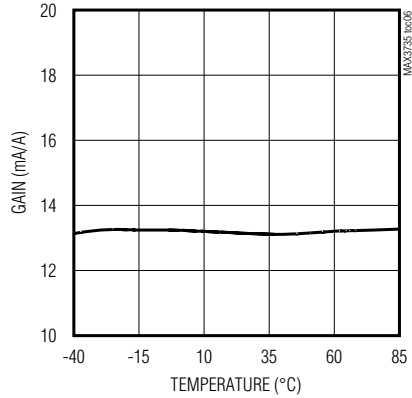

# 2.7Gbps, Low-Power SFP Laser Drivers

MAX3735/MAX3735A

## Typical Operating Characteristics (continued)

( $V_{CC} = +3.3V$ ,  $C_{APC} = 0.01\mu F$ ,  $I_{BIAS} = 20mA$ , and  $I_{MOD} = 30mA$ ,  $T_A = +25^\circ C$ , unless otherwise noted.)

**PHOTOCURRENT MONITOR GAIN vs. TEMPERATURE**

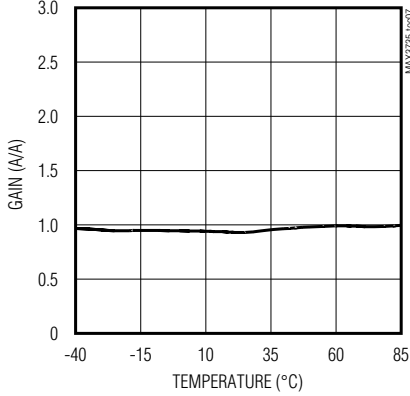

**MODULATION CURRENT vs. R<sub>MODSET</sub>**

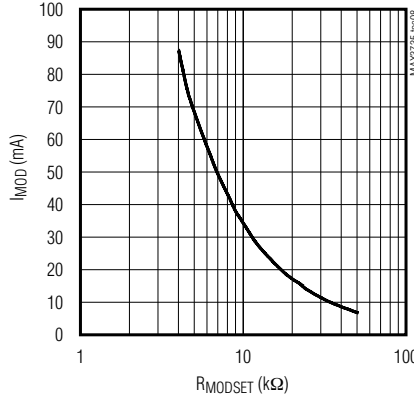

**MONITOR DIODE CURRENT vs. R<sub>APCSET</sub>**

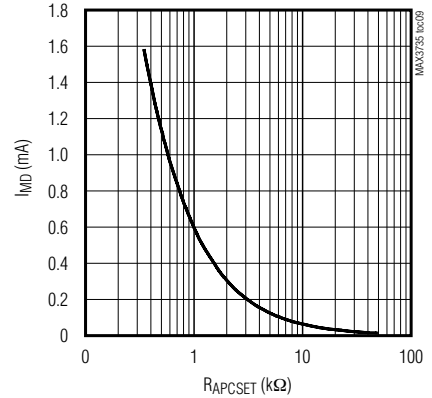

**EDGE TRANSITION TIME vs. MODULATION CURRENT**

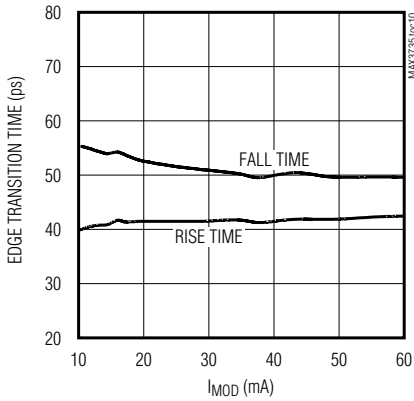

**DETERMINISTIC JITTER vs. MODULATION CURRENT**

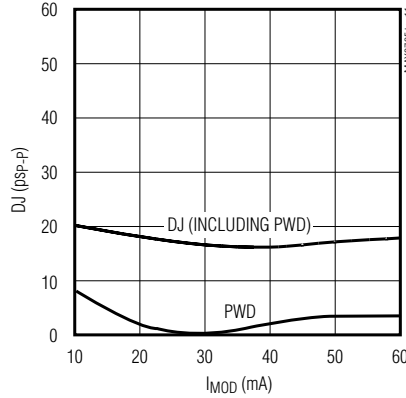

**RANDOM JITTER vs. MODULATION CURRENT**

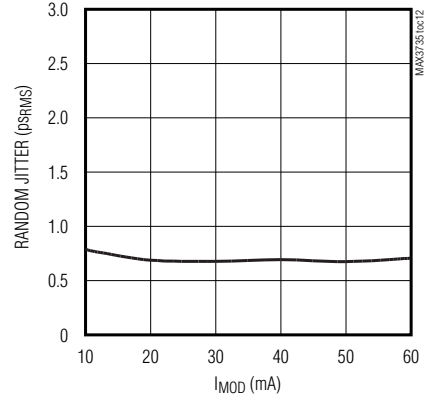

**HOT PLUG WITH TX\_DISABLE LOW**

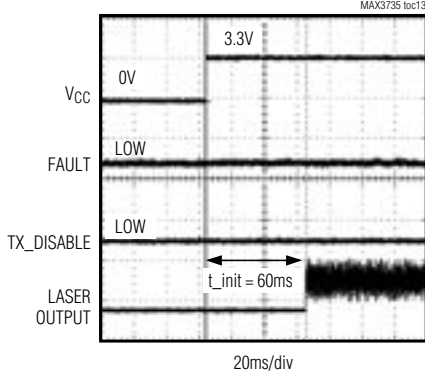

**STARTUP WITH SLOW RAMPING SUPPLY**

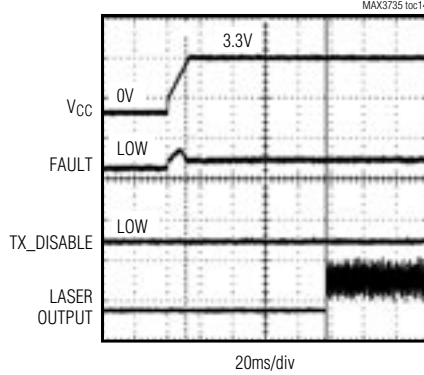

**TRANSMITTER ENABLE**

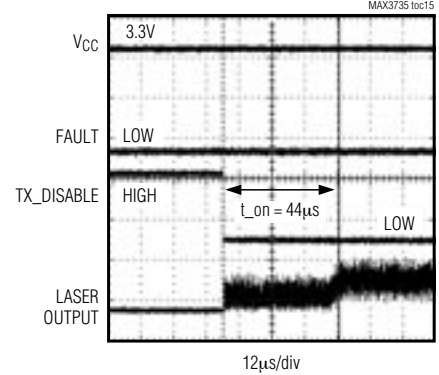

# 2.7Gbps, Low-Power SFP Laser Drivers

## Typical Operating Characteristics (continued)

( $V_{CC} = +3.3V$ ,  $C_{APC} = 0.01\mu F$ ,  $I_{BIAS} = 20mA$ , and  $I_{MOD} = 30mA$ ,  $T_A = +25^\circ C$ , unless otherwise noted.)

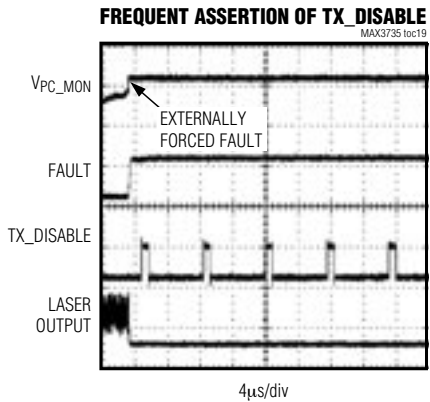
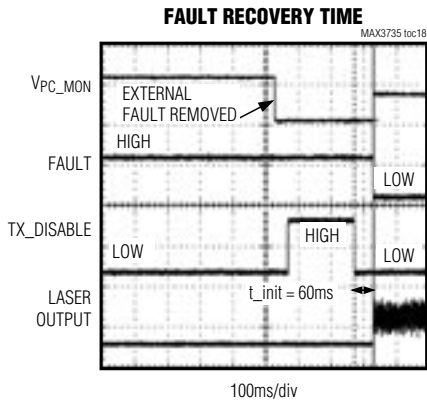
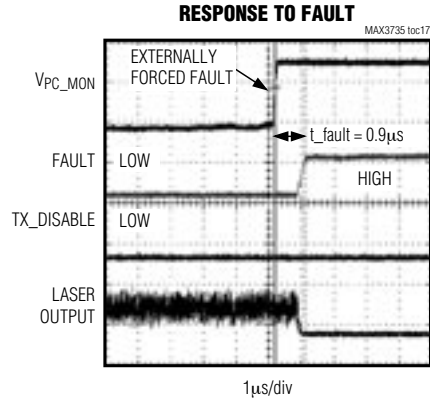
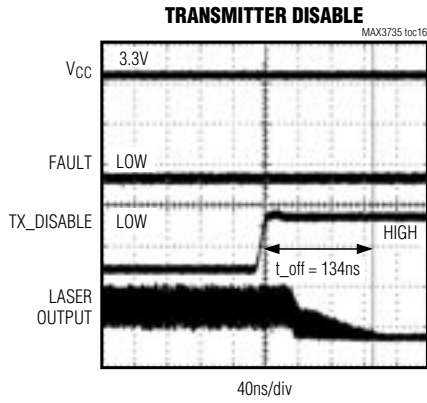



# 2.7Gbps, Low-Power SFP Laser Drivers

MAX3735/MAX3735A

## Pin Description

PIN	NAME	FUNCTION
1, 4, 8, 14, 18	VCC	+3.3V Supply Voltage
2	IN+	Noninverted Data Input
3	IN-	Inverted Data Input
5	PC_MON	Photodiode Current Monitor Output. Current out of this pin develops a ground-referenced voltage across an external resistor that is proportional to the monitor diode current.
6	BC_MON	Bias Current Monitor Output. Current out of this pin develops a ground-referenced voltage across an external resistor that is proportional to the bias current.
7, 12, 22	GND	Ground
9	SHUTDOWN	Shutdown Driver Output. Voltage output to control an external transistor for optional shutdown circuitry.
10	TX_FAULT	Open-Collector Transmit Fault Indicator (Table 1).
11	MODSET	A resistor connected from this pad to ground sets the desired modulation current.
13	BIAS	Laser Bias Current Output
15, 16	OUT+	Noninverted Modulation Current Output. Connect pins 15 and 16 externally to minimize parasitic inductance of the package. $I_{MOD}$ flows into this pin when input data is high.
17	OUT-	Inverted Modulation Current Output. $I_{MOD}$ flows into this pin when input data is low.
19	MD	Monitor Diode Input. Connect this pin to the anode of a monitor photodiode. A capacitor to ground is required to filter the high-speed AC monitor photocurrent.
20	APCFILT1	Connect a capacitor ( $C_{APC}$ ) between pin 20 (APCFILT1) and pin 21 (APCFILT2) to set the dominant pole of the APC feedback loop.
21	APCFILT2	See APCFILT1
23	APCSET	A resistor connected from this pin to ground sets the desired average optical power.
24	TX_DISABLE	Transmitter Disable, TTL. Laser output is disabled when TX_DISABLE is asserted high or left unconnected. The laser output is enabled when this pin is asserted low.
EP	Exposed Pad	Ground. Must be soldered to the circuit board ground for proper thermal and electrical performance (see the <i>Exposed Pad Package</i> section).

## Detailed Description

The MAX3735/MAX3735A laser drivers consist of three parts: a high-speed modulation driver, a laser-biasing block with automatic power control (APC), and safety circuitry (Figure 4). The circuit design is optimized for high-speed and low-voltage (+3.3V) operation.

### High-Speed Modulation Driver

The output stage are composed of a high-speed differential pair and a programmable modulation current source. The MAX3735/MAX3735A are optimized for driving a  $15\Omega$  load; the minimum instantaneous voltage required at OUT+ is 0.6V. Modulation current swings up to 60mA are possible when the laser diode is DC-coupled to the driver and up to 85mA when the laser diode is AC-coupled to the driver.

To interface with the laser diode, a damping resistor ( $R_D$ ) is required for impedance matching. The combined resistance of the series damping resistor and the equivalent series resistance of the laser diode should equal  $15\Omega$ . To reduce optical output aberrations and duty-cycle distortion caused by laser diode parasitic inductance, an RC shunt network might be necessary. Refer to Maxim Application Note HFAN 02.0: *Interfacing Maxim's Laser Drivers to Laser Diodes* for more information.

At data rates of 2.7Gbps, any capacitive load at the cathode of a laser diode degrades optical output performance. Because the BIAS output is directly connected to the laser cathode, minimize the parasitic capacitance associated with the pin by using an inductor to isolate the BIAS pin parasitics from the laser cathode.

## 2.7Gbps, Low-Power SFP Laser Drivers

MAX3735/MAX3735A

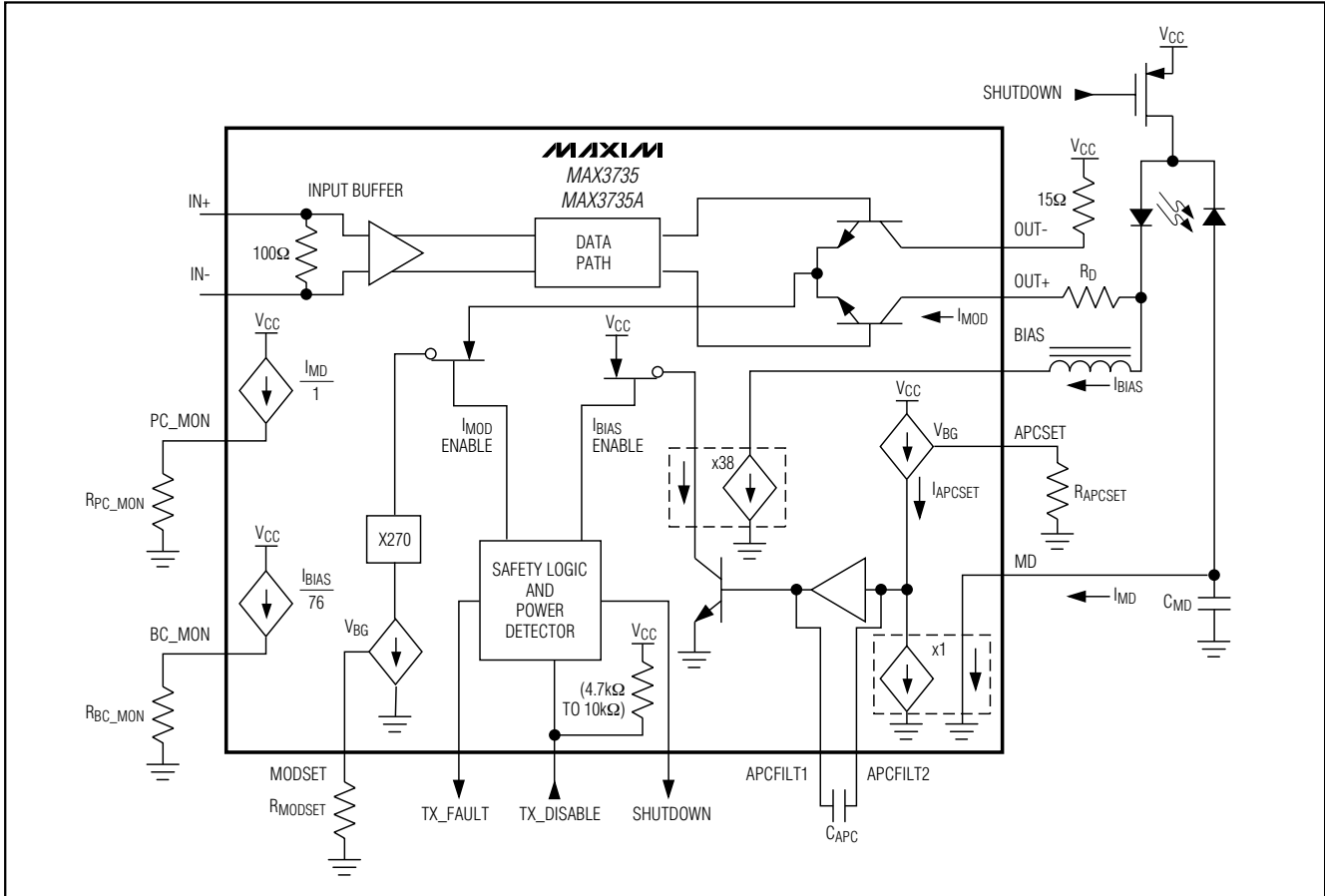

Figure 4. Functional Diagram

### Laser-Biasing and APC

To maintain constant average optical power, the MAX3735/MAX3735A incorporate an APC loop to compensate for the changes in laser threshold current over temperature and lifetime. A back-facet photodiode mounted in the laser package is used to convert the optical power into a photocurrent. The APC loop adjusts the laser bias current so that the monitor current is matched to a reference current set by  $R_{APCCSET}$ . The time constant of the APC loop is determined by an external capacitor ( $C_{CAPC}$ ). For possible  $C_{CAPC}$  values, see the *Applications Information* section.

### Safety Circuitry

The safety circuitry contains an input disable ( $TX\_DISABLE$ ), a latched fault output ( $TX\_FAULT$ ), and fault detectors (Figure 5). This circuitry monitors the operation of the laser driver and forces a shutdown if a fault is detected (Table 1). A single-point fault can be a short to  $V_{CC}$  or  $GND$ . See Table 2 to view the circuit

response to various single-point failures. The transmit fault condition is latched until reset by a toggle of  $TX\_DISABLE$  or  $V_{CC}$ . The laser driver offers redundant laser diode shutdown through the optional shutdown circuitry (see the *Typical Applications Circuit*). The  $TX\_FAULT$  pin should be pulled high with a  $4.7k\Omega$  to  $10k\Omega$  resistor to  $V_{CC}$  as required by the SFP MSA.

### Safety Circuitry Current Monitors

The MAX3735/MAX3735A feature monitors ( $BC\_MON$ ,  $PC\_MON$ ) for bias current ( $I_{BIAS}$ ) and photo current ( $I_{MD}$ ). The monitors are realized by mirroring a fraction of the currents and developing voltages across external resistors connected to ground. Voltages greater than 1.38V at  $PC\_MON$  or  $BC\_MON$  result in a fault state. For example, connecting a  $100\Omega$  resistor to ground on each monitor output gives the following relationships:

$$V_{BC\_MON} = (I_{BIAS} / 76) \times 100\Omega$$

$$V_{PC\_MON} = I_{MD} \times 100\Omega$$

## 2.7Gbps, Low-Power SFP Laser Drivers

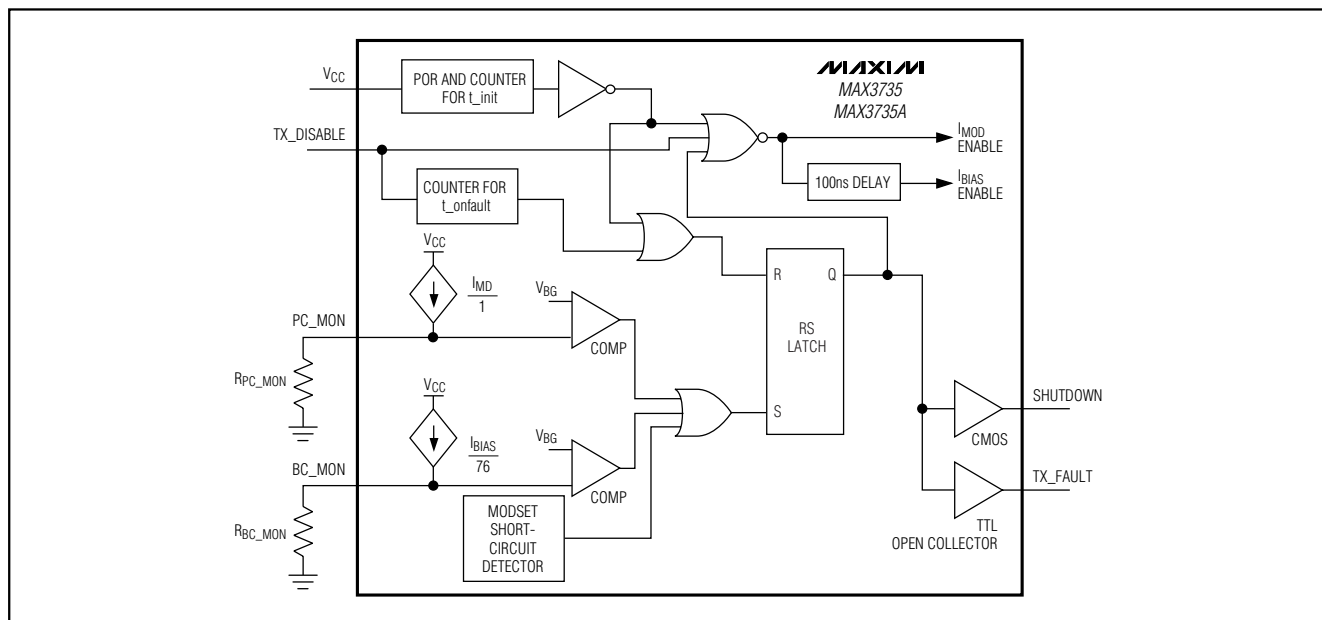

Figure 5. Safety Circuitry

**Table 1. Typical Fault Conditions**

1.	If any of the I/O pins is shorted to GND or V <sub>CC</sub> (single-point failure, see Table 2), and the bias current or the photocurrent exceed the programmed threshold.
2.	End-of-life (EOL) condition of the laser diode. The bias current and/or the photocurrent exceed the programmed threshold.
3.	Laser cathode is grounded and the photocurrent exceeds the programmed thresholds.
4.	No feedback for the APC loop (broken interconnection, defective monitor photodiode), and the bias current exceeds the programmed threshold.

### Design Procedure

When designing a laser transmitter, the optical output usually is expressed in terms of average power and extinction ratio. Table 3 shows relationships helpful in converting between the optical average power and the modulation current. These relationships are valid if the mark density and duty cycle of the optical waveform are 50%.

#### Programming the Modulation Current

For a given laser power ( $P_{AVG}$ ), slope efficiency ( $\eta$ ), and extinction ratio ( $r_e$ ), the modulation current can be calculated using Table 3. See the Modulation Current vs.  $R_{MODSET}$  graph in the *Typical Operating Characteristics*

section, and select the value of  $R_{MODSET}$  that corresponds to the required current at +25°C.

#### Programming the APC Loop

Program the average optical power by adjusting  $-R_{APCSET}$ . To select the resistance, determine the desired monitor current to be maintained over temperature and lifetime. See the Monitor Diode Current vs.  $R_{APCSET}$  graph in the *Typical Operating Characteristics* section, and select the value of  $R_{APCSET}$  that corresponds to the required current.

#### Interfacing with Laser Diodes

To minimize optical output aberrations caused by signal reflections at the electrical interface to the laser diode, a series-damping resistor ( $R_D$ ) is required (Figure 4). Additionally, the MAX3735/MAX3735A outputs are optimized for a 15Ω load. Therefore, the series combination of  $R_D$  and  $R_L$ , where  $R_L$  represents the laser-diode resistance, should equal 15Ω. Typical values for  $R_D$  are 8Ω to 13Ω. For best performance, place a bypass capacitor (0.01μF typ) as close as possible to the anode of the laser diode. An RC shunt network between the laser cathode and ground minimizes optical output aberrations. Starting values for most coaxial lasers are  $R_{COMP} = 50\Omega$  in series with  $C_{COMP} = 8pF$ . Adjust these values experimentally until the optical output waveform is optimized. Refer to Maxim Application Note: HFAN 02.0: *Interfacing Maxim's Laser Drivers to Laser Diodes* for more information.

## 2.7Gbps, Low-Power SFP Laser Drivers

**Table 2. Circuit Responses to Various Single-Point Faults**

PIN NAME	CIRCUIT RESPONSE TO OVERVOLTAGE OR SHORT TO V <sub>CC</sub>	CIRCUIT RESPONSE TO UNDERVOLTAGE OR SHORT TO GROUND
TX_FAULT	Does not affect laser power.	Does not affect laser power.
TX_DISABLE	Modulation and bias currents are disabled.	Normal condition for circuit operation.
IN+	The optical average power increases and a fault occurs if V <sub>PC_MON</sub> exceeds the threshold. The APC loop responds by decreasing the bias current.	The optical average power decreases and the APC loop responds by increasing the bias current. A fault state occurs if V <sub>BC_MON</sub> exceeds the threshold voltage.
IN-	The optical average power decreases and the APC loop responds by increasing the bias current. A fault state occurs if V <sub>BC_MON</sub> exceeds the threshold voltage.	The optical average power increases and a fault occurs if V <sub>PC_MON</sub> exceeds the threshold. The APC loop responds by decreasing the bias current.
MD	Disables bias current. A fault state occurs.	The APC circuit responds by increasing bias current until a fault is detected, then a fault state* occurs.
SHUTDOWN	Does not affect laser power. If the shutdown circuitry is used, laser current is disabled and a fault state* occurs.	Does not affect laser power.
BIAS	In this condition, laser forward voltage is 0V and no light is emitted.	Fault state* occurs. If the shutdown circuitry is used, the laser current is disabled.
OUT+	The APC circuit responds by increasing the bias current until a fault is detected, then a fault state* occurs.	Fault state* occurs. If the shutdown circuitry is used, laser current is disabled.
OUT-	Does not affect laser power.	Does not affect laser power.
PC_MON	Fault state* occurs.	Does not affect laser power.
BC_MON	Fault state* occurs.	Does not affect laser power.
APCFILT1	IBIAS increases until V <sub>BC_MON</sub> exceeds the threshold voltage.	IBIAS increases until V <sub>BC_MON</sub> exceeds the threshold voltage.
APCFILT2	IBIAS increases until V <sub>BC_MON</sub> exceeds the threshold voltage.	IBIAS increases until V <sub>BC_MON</sub> exceeds the threshold voltage.
MODSET	Does not affect laser power.	Fault state* occurs.
APCSET	Does not affect laser power.	Fault state* occurs.

\*A fault state asserts the TX\_FAULT pin, disables the modulation and bias currents, and asserts the SHUTDOWN pin.

**Table 3. Optical Power Definitions**

PARAMETER	SYMBOL	RELATION
Average Power	P <sub>AVG</sub>	$P_{AVG} = (P_0 + P_1) / 2$
Extinction Ratio	r <sub>e</sub>	$r_e = P_1 / P_0$
Optical Power High	P <sub>1</sub>	$P_1 = 2P_{AVG} \times r_e / (r_e + 1)$
Optical Power Low	P <sub>0</sub>	$P_0 = 2P_{AVG} / (r_e + 1)$
Optical Amplitude	P <sub>P-P</sub>	$P_{P-P} = P_1 - P_0$
Laser Slope Efficiency	η	$\eta = P_{P-P} / I_{MOD}$
Modulation Current	I <sub>MOD</sub>	$I_{MOD} = P_{P-P} / \eta$

### Pattern-Dependent Jitter

To minimize the pattern-dependent jitter associated with the APC loop time constant, and to guarantee loop stability, connect a capacitor between APCFIL1 and APCFIL2 (see the *Applications Information* section for more information about choosing C<sub>APC</sub> values). A capacitor attached to the photodiode anode (CMD) is also recommended to filter transient currents that originate from the photodiode. To maintain stability and proper phase margin associated with the two poles created by C<sub>APC</sub> and CMD, C<sub>APC</sub> should be 20x greater than CMD for the MAX3735. C<sub>APC</sub> should be 4x to 20x greater than CMD for the MAX3735A.

# 2.7Gbps, Low-Power SFP Laser Drivers

## Input Termination Requirements

The MAX3735/MAX3735A data inputs are SFP MSA compliant. On-chip 100Ω differential input impedance is provided for optimal termination (Figure 6). Because of the on-chip biasing network, the MAX3735/MAX3735A inputs self-bias to the proper operating point to accommodate AC-coupling.

## Optional Shutdown Output Circuitry

The SHUTDOWN control output features extended eye safety when the laser cathode is grounded. An external transistor is required to implement this circuit (Figure 4). In the event of a fault, SHUTDOWN asserts high, placing the optional shutdown transistor in cutoff mode and thereby shutting off the laser current.

## Applications Information

An example of how to set up the MAX3735/MAX3735A follows:

Select a communications-grade laser for 2.488Gbps. Assume that the laser output average power is  $P_{AVG} = 0\text{dBm}$ , the operating temperature is  $-40^{\circ}\text{C}$  to  $+85^{\circ}\text{C}$ , minimum extinction ratio is 6.6 (8.2dB), and the laser diode has the following characteristics:

- Wavelength:  $\lambda = 1.3\mu\text{m}$
- Threshold current:  $I_{TH} = 22\text{mA}$  at  $+25^{\circ}\text{C}$
- Threshold temperature coefficient:  $\beta_{TH} = 1.3\% / ^{\circ}\text{C}$
- Laser-to-monitor transfer:  $\rho_{MON} = 0.2\text{A/W}$
- Laser slope efficiency:  $\eta = 0.05\text{mW/mA}$  at  $+25^{\circ}\text{C}$

## Determine $R_{APCSET}$

The desired monitor diode current is estimated by  $I_{MD} = P_{AVG} \times \rho_{MON} = 200\mu\text{A}$ . The Monitor Diode vs.  $R_{APCSET}$  graph in the *Typical Operating Characteristics* section shows that  $R_{APCSET}$  should be  $3\text{k}\Omega$ . The value can also be estimated using the equation below:

$$I_{MD} = 1.23 / (2 \times R_{APCSET})$$

## Determine $R_{MODSET}$

To achieve a minimum extinction ratio ( $r_e$ ) of 6.6 over temperature and lifetime, calculate the required extinction ratio at  $+25^{\circ}\text{C}$ . Assuming the results of the calculation are  $r_e = 20$  at  $+25^{\circ}\text{C}$ , the peak-to-peak optical power  $P_{P-P} = 1.81\text{mW}$ , according to Table 3. The required modulation current is  $1.81\text{mW} / (0.05\text{mW/mA}) = 36.2\text{mA}$ . The Modulation Current vs.  $R_{MODSET}$  graph in the *Typical Operating Characteristics* section shows that  $R_{MODSET}$  should be  $9.5\text{k}\Omega$ . The value can also be estimated using the equation below:

$$I_{MOD} = 1.23 / (0.0037 \times R_{MODSET})$$

## Determine $C_{APC}$

In order to meet SFP timing requirements and minimize pattern-dependent jitter, the  $C_{APC}$  capacitor value is determined by the laser-to-monitor transfer and other variables. The following equations and table can be used to choose the  $C_{APC}$  values for the MAX3735 and MAX3735A, respectively. The equations and table assume a DC-coupled laser. Refer to Maxim Application Note HFDN 23.0: *Choosing the APC Loop*

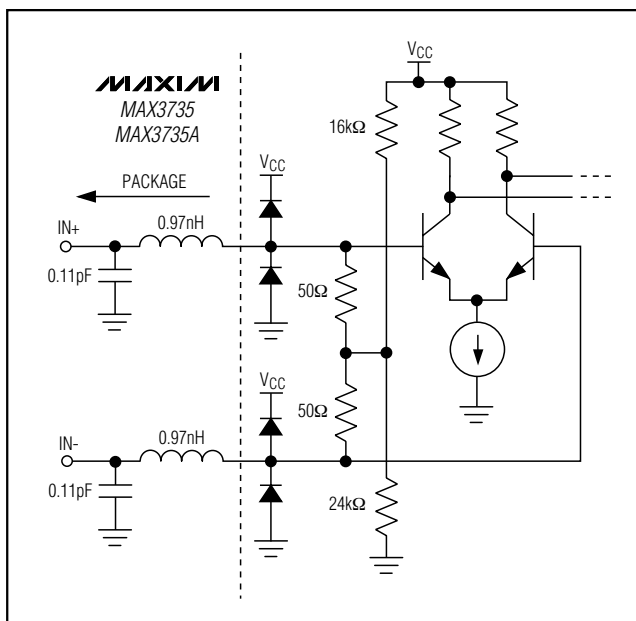

Figure 6. Simplified Input Structure

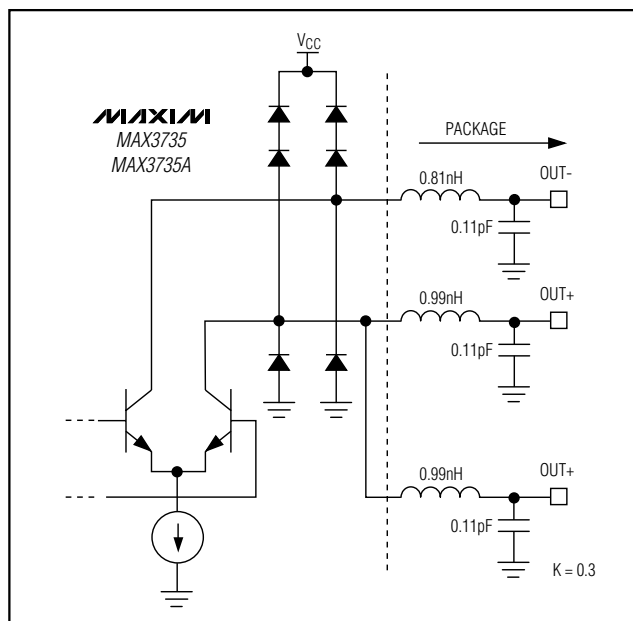

Figure 7. Simplified Output Structure

## 2.7Gbps, Low-Power SFP Laser Drivers

Capacitors Used with MAX3735/MAX3735A SFP Module Designs for more information on choosing C<sub>APC</sub> for DC- and AC-coupled laser interfaces.

### MAX3735

Use the following equation to find the C<sub>APC</sub> value when using the MAX3735:

$$C_{APC} = 4.04 \times 10^{-9} \times t_{ON} \times \eta \times \rho_{MON} (29.3 + 20.6 I_{TH} - 0.22 I_{TH}^2) \times (1947 + 833 I_{MOD} - 7.78 I_{MOD}^2 + 0.103 I_{MOD}^3)$$

where units are:

C<sub>APC</sub> in  $\mu$ F, I<sub>TH</sub> and I<sub>MOD</sub> in mA and t<sub>ON</sub> in  $\mu$ s. C<sub>MD</sub> can then be chosen as approximately 20x smaller than C<sub>APC</sub> for the MAX3735.

### MAX3735A

Use Table 4 to choose C<sub>APC</sub> when using the MAX3735A. C<sub>APC</sub> should be chosen according to the highest gain of the lasers (generally at cold temperature). C<sub>APC</sub> selection assumes a 34% reduction in the gain of the lasers at +85°C from the cold (-40°C) values.

**Table 4. MAX3735A C<sub>APC</sub> Selection**

LASER GAIN (A/A)	C <sub>APC</sub> ( $\mu$ F)
0.005	0.039
0.007	0.047
0.010	0.068
0.020	0.100
0.030	0.120
0.040	0.120

where Gain = I<sub>MD</sub>/(I<sub>BIAS</sub> - I<sub>TH</sub> + 0.5 x I<sub>MOD</sub>) for DC-coupled lasers. C<sub>MD</sub> can then be chosen as approximately 4x to 20x smaller than C<sub>APC</sub> for the MAX3735A

### Using the MAX3735/MAX3735A with Digital Potentiometers

For more information on using the MAX3735/MAX3735A with the Dallas DS1858/DS1859 SFP controller, refer to Maxim Application Note HFAN 2.3.3: *Optimizing the Resolution of Laser Driver Setting Using Linear Digital Potentiometers* for more information.

### Modulation Currents Exceeding 60mA

For applications requiring a modulation current greater than 60mA, headroom is insufficient for proper operation of the laser driver if the laser is DC-coupled. To avoid this problem, the MAX3735/MAX3735A's modulation output can be AC-coupled to the cathode of a laser diode. An external pullup inductor is necessary to DC-bias the modulation output at V<sub>CC</sub>. Such a configuration

isolates laser forward voltage from the output circuitry and allows the output at OUT+ to swing above and below the supply voltage (V<sub>CC</sub>). When AC-coupled, the MAX3735/MAX3735A modulation current can be programmed from 10mA to 85mA. Refer to Maxim Application Note HFAN 02.0: *Interfacing Maxim's Laser Drivers to Laser Diodes* for more information on AC-coupling laser drivers to laser diodes.

### Interface Models

Figures 6 and 7 show simplified input and output circuits for the MAX3735/MAX3735A laser driver. If dice are used, replace package parasitic elements with bondwire parasitic elements.

### Wire Bonding Die

The MAX3735 uses gold metalization with a thickness of 5 $\mu$ m (typ). Maxim characterized this circuit with gold wire ball bonding (1-mil diameter wire). Die-pad size is 94 mil (2388 $\mu$ m) square, and die thickness is 15 mil (381 $\mu$ m). Refer to Maxim Application Note HFAN-08.0.1: *Understanding Bonding Coordinates and Physical Die Size* for additional information.

### Layout Considerations

To minimize inductance, keep the connections between the MAX3735 output pins and laser diode as close as possible. Optimize the laser diode performance by placing a bypass capacitor as close as possible to the laser anode. Use good high-frequency layout techniques and multiple-layer boards with uninterrupted ground planes to minimize EMI and crosstalk.

### Exposed-Pad Package

The exposed pad on the 24-pin QFN provides a very low thermal resistance path for heat removal from the IC. The pad is also electrical ground on the MAX3735/MAX3735A and must be soldered to the circuit board ground for proper thermal and electrical performance. Refer to Maxim Application Note HFAN-08.1: *Thermal Considerations for QFN and Other Exposed-Pad Packages* for additional information.

### Laser Safety and IEC 825

Using the MAX3735/MAX3735A laser driver alone does not ensure that a transmitter design is compliant with IEC 825. The entire transmitter circuit and component selections must be considered. Each user must determine the level of fault tolerance required by the application, recognizing that Maxim products are neither designed nor authorized for use as components in systems intended for surgical implant into the body, for applications intended to support or sustain life, or for any other application in which the failure of a Maxim product could create a situation where personal injury or death may occur.



# 2.7Gbps, Low-Power SFP Laser Drivers

## MAX3735 Chip Topography

MAX3735/MAX3735A

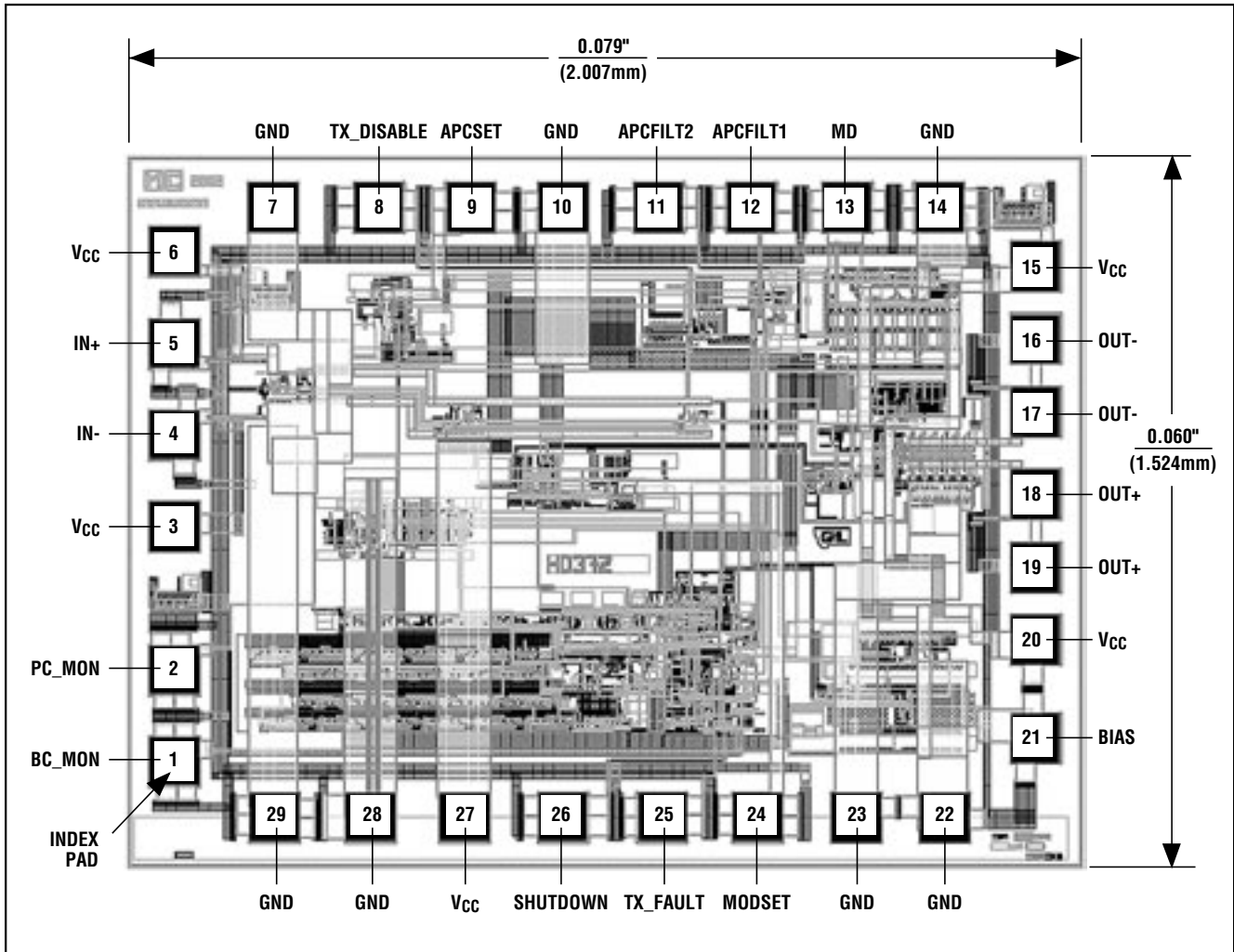

# 2.7Gbps, Low-Power SFP Laser Drivers

## Bonding Coordinates

**Table 5. MAX3735 Bondpad Locations**

PAD	NAME	COORDINATES	
		X	Y
1*	BC_MON	47	47
2	PC_MON	47	229
3	V <sub>CC</sub>	47	514
4	IN-	47	696
5	IN+	47	878
6	V <sub>CC</sub>	47	1063
7	GND	242	1149
8	TX_DISABLE	452	1149
9	APCSET	636	1149
10	GND	819	1149
11	APCFILT2	1008	1149
12	APCFILT1	1193	1149
13	MD	1383	1149
14	GND	1567	1149
15	V <sub>CC</sub>	1758	1032
16**	OUT-	1758	888
17**	OUT-	1758	742
18**	OUT+	1758	579
19**	OUT+	1758	433
20	V <sub>CC</sub>	1758	289
21	BIAS	1758	93
22	GND	1578	-64
23	GND	1401	-64
24	MODSET	1205	-64
25	TX_FAULT	1016	-64
26	SHUTDOWN	818	-64
27	V <sub>CC</sub>	623	-64
28	GND	435	-64
29	GND	245	-64

\*Index pad. Orient the die with this pad in the lower-left corner.

\*\*Bond out both pairs of OUT- and OUT+ to minimize series inductance.

## Pin Configuration

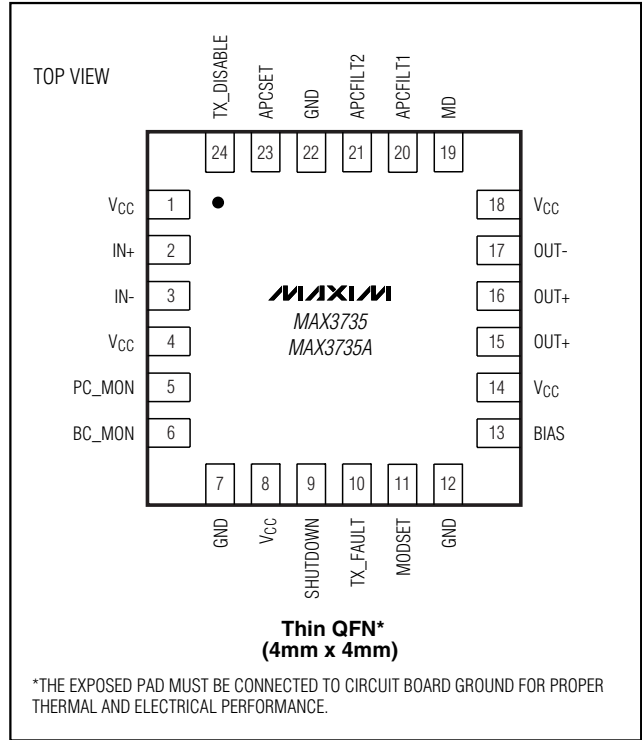

## Chip Information

TRANSISTOR COUNT: 327  
 SUBSTRATE CONNECTED TO GND  
 DIE SIZE: 60 mils x 79 mils  
 PROCESS: SiGe Bipolar



# 2.7Gbps, Low-Power SFP Laser Drivers

## Package Information

(The package drawing(s) in this data sheet may not reflect the most current specifications. For the latest package outline information, go to [www.maxim-ic.com/packages](http://www.maxim-ic.com/packages).)

MAX3735/MAX3735A

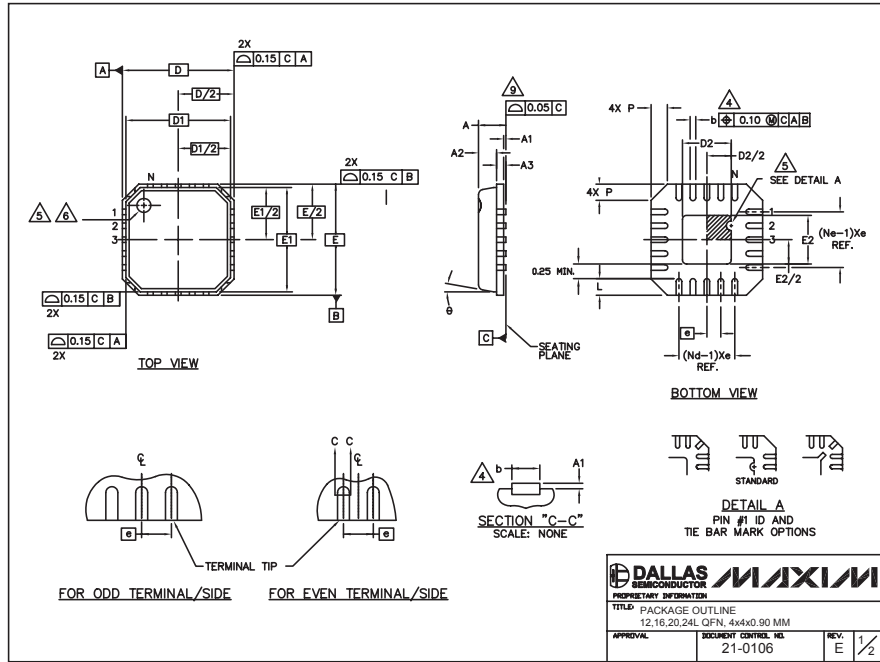

### NOTES:

- DIE THICKNESS ALLOWABLE IS 0.305mm MAXIMUM (.012 INCHES MAXIMUM).
- DIMENSIONING & TOLERANCES CONFORM MUST TO ASME Y14.5M - 1994.
- N IS THE NUMBER OF TERMINALS.  
Nd IS THE NUMBER OF TERMINALS IN X-DIRECTION &  
Ne IS THE NUMBER OF TERMINALS IN Y-DIRECTION.
- DIMENSION b APPLIES TO PLATED TERMINAL AND IS MEASURED BETWEEN 0.20 AND 0.25mm FROM TERMINAL TIP.
- THE PIN #1 IDENTIFIER MUST BE EXISTED ON THE TOP SURFACE OF THE PACKAGE BY USING INDENTATION MARK OR INK/LASER MARKED. DETAILS OF PIN #1 IDENTIFIER IS OPTIONAL, BUT MUST BE LOCATED WITHIN ZONE INDICATED.
- EXACT SHAPE AND SIZE OF THIS FEATURE IS OPTIONAL.
- ALL DIMENSIONS ARE IN MILLIMETERS.
- PACKAGE WARPAGE MAX 0.05mm.
- APPLIED FOR EXPOSED PAD AND TERMINALS. EXCLUDE EMBEDDING PART OF EXPOSED PAD FROM MEASURING.
- MEETS JEDEC MO220; EXCEPT DIMENSION "b".
- THIS PACKAGE OUTLINE APPLIES TO PUNCHED QFN (STEPPED SIDES).

PITCH VARIATION A				PITCH VARIATION B				PITCH VARIATION C				PITCH VARIATION D			
MIN.	NOM.	MAX.		MIN.	NOM.	MAX.		MIN.	NOM.	MAX.		MIN.	NOM.	MAX.	
0.80	BSC			0.65	BSC			0.50	BSC			0.50	BSC		
N	12		3	N	16		3	N	20		3	N	24		3
Nd	3		3	Nd	4		3	Nd	5		3	Nd	6		3
Ne	3		3	Ne	4		3	Ne	5		3	Ne	6		3
L	0.50	0.60	0.75	L	0.50	0.60	0.75	L	0.50	0.60	0.75	L	0.30	0.40	0.50
b	0.28	0.33	0.40	b	0.23	0.28	0.35	b	0.18	0.23	0.30	b	0.18	0.23	0.30

PKG. CODE	D2			E2		
	MIN.	NOM.	MAX.	MIN.	NOM.	MAX.
G1244-2	1.95	2.10	2.25	1.95	2.10	2.25
G1644-1	1.95	2.10	2.25	1.95	2.10	2.25
G2044-3	1.95	2.10	2.25	1.95	2.10	2.25
G2044-4	1.55	1.70	1.85	1.55	1.70	1.85
G2444-1	1.95	2.10	2.25	1.95	2.10	2.25

**DALLAS SEMICONDUCTOR** **MAXIM**

PROPRIETARY INFORMATION

TITLE: PACKAGE OUTLINE  
12,16,20,24L QFN, 4x4x0.90 MM

APPROVAL: \_\_\_\_\_ DOCUMENT CONTROL: 21-0106 REV: E 2/2

# 2.7Gbps, Low-Power SFP Laser Drivers

## Package Information

(The package drawing(s) in this data sheet may not reflect the most current specifications. For the latest package outline information, go to [www.maxim-ic.com/packages](http://www.maxim-ic.com/packages).)

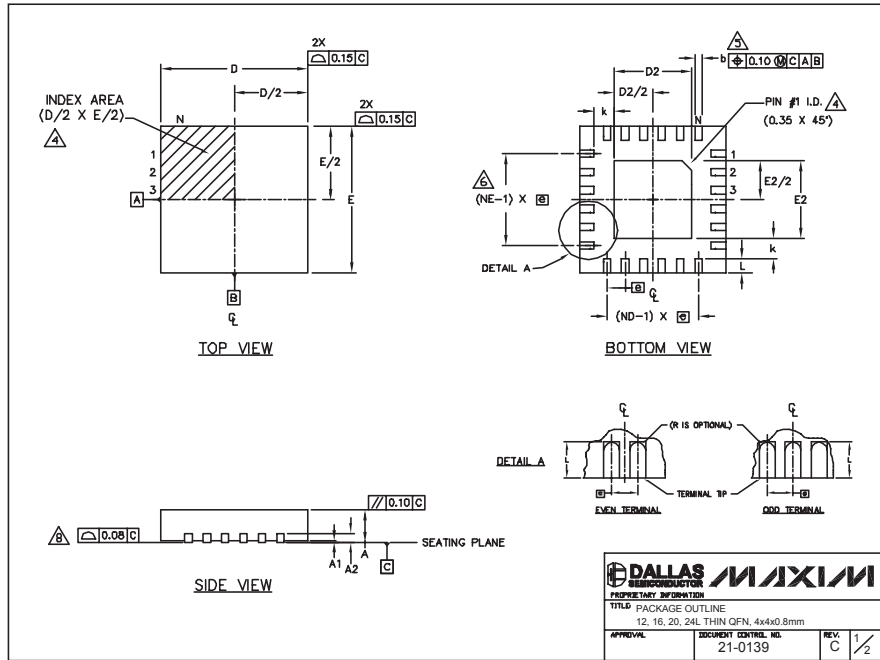

24L QFN THIN EPS

PKG REF.	COMMON DIMENSIONS												EXPOSED PAD VARIATIONS								
	12L 4x4			16L 4x4			20L 4x4			24L 4x4			PKG CODES	D2			E2			DOWN BONDS ALLOWED	
MIN.	NDM.	MAX.	MIN.	NDM.	MAX.	MIN.	NDM.	MAX.	MIN.	NDM.	MAX.	MIN.		NDM.	MAX.	MIN.	NDM.	MAX.			
A	0.70	0.75	0.80	0.70	0.75	0.80	0.70	0.75	0.80	0.70	0.75	0.80	T1244-2	1.95	2.10	2.25	1.95	2.10	2.25	YES	
AI	0.0	0.02	0.05	0.0	0.02	0.05	0.0	0.02	0.05	0.0	0.02	0.05	T1244-3	1.95	2.10	2.25	1.95	2.10	2.25	YES	
AE	0.20 REF			0.20 REF			0.20 REF			0.20 REF			T1244-4	1.95	2.10	2.25	1.95	2.10	2.25	NO	
b	0.25	0.30	0.35	0.25	0.30	0.35	0.20	0.25	0.30	0.18	0.23	0.30	T1644-2	1.95	2.10	2.25	1.95	2.10	2.25	NO	
D	3.90	4.00	4.10	3.90	4.00	4.10	3.90	4.00	4.10	3.90	4.00	4.10	T1644-3	1.95	2.10	2.25	1.95	2.10	2.25	YES	
E	3.90	4.00	4.10	3.90	4.00	4.10	3.90	4.00	4.10	3.90	4.00	4.10	T1644-4	1.95	2.10	2.25	1.95	2.10	2.25	NO	
e	0.80 BSC			0.65 BSC			0.50 BSC			0.50 BSC			T2044-1	1.95	2.10	2.25	1.95	2.10	2.25	NO	
k	0.25	-	-	0.25	-	-	0.25	-	-	0.25	-	-	T2044-2	1.95	2.10	2.25	1.95	2.10	2.25	YES	
L	0.45	0.55	0.65	0.45	0.55	0.65	0.45	0.55	0.65	0.30	0.40	0.50	T2044-3	1.95	2.10	2.25	1.95	2.10	2.25	NO	
N	12	-	-	16	-	-	20	-	-	24	-	-	T2444-1	2.45	2.60	2.63	2.45	2.60	2.63	NO	
ND	3	-	-	4	-	-	5	-	-	6	-	-	T2444-2	1.95	2.10	2.25	1.95	2.10	2.25	YES	
NE	3	-	-	4	-	-	5	-	-	6	-	-	T2444-3	2.45	2.60	2.63	2.45	2.60	2.63	YES	
Ver.	WGGB			WGGC			WGGD-1			WGGD-2			T2444-4	2.45	2.60	2.63	2.45	2.60	2.63	NO	

NOTES:

- DIMENSIONING & TOLERANCING CONFORM TO ASME Y14.5M-1994.
- ALL DIMENSIONS ARE IN MILLIMETERS. ANGLES ARE IN DEGREES.
- N IS THE TOTAL NUMBER OF TERMINALS.
- THE TERMINAL #1 IDENTIFIER AND TERMINAL NUMBERING CONVENTION SHALL CONFORM TO JEDEC 95-1 SPP-012. DETAILS OF TERMINAL #1 IDENTIFIER ARE OPTIONAL, BUT MUST BE LOCATED WITHIN THE ZONE INDICATED. THE TERMINAL #1 IDENTIFIER MAY BE EITHER A MOLD OR MARKED FEATURE.
- DIMENSION b APPLIES TO METALLIZED TERMINAL AND IS MEASURED BETWEEN 0.25 mm AND 0.30 mm FROM TERMINAL TIP.
- ND AND NE REFER TO THE NUMBER OF TERMINALS ON EACH D AND E SIDE RESPECTIVELY.
- DEPOPULATION IS POSSIBLE IN A SYMMETRICAL FASHION.
- COPLANARITY APPLIES TO THE EXPOSED HEAT SINK SLUG AS WELL AS THE TERMINALS.
- DRAWING CONFORMS TO JEDEC M0220, EXCEPT FOR T2444-1, T2444-3 AND T2444-4.

PROPRIETARY INFORMATION  
TITLE: PACKAGE OUTLINE  
12, 16, 20, 24L THIN QFN, 4x4x0.8mm  
APPROVAL: \_\_\_\_\_ DOCUMENT CONTROL NO. 21-0139 REV. C 2/2

Maxim cannot assume responsibility for use of any circuitry other than circuitry entirely embodied in a Maxim product. No circuit patent licenses are implied. Maxim reserves the right to change the circuitry and specifications without notice at any time.

18 **Maxim Integrated Products, 120 San Gabriel Drive, Sunnyvale, CA 94086 408-737-7600**



SITE SEARCH

PART NO. SEARCH

# MAX3735

## Part Number Table

Notes:

1. See the [MAX3735 QuickView Data Sheet](#) for further information on this product family or download the [MAX3735 full data sheet](#) (PDF, 1.1MB).
2. Other options and links for purchasing parts are listed at: <http://www.maxim-ic.com/sales>.
3. [Didn't Find What You Need?](#) Ask our applications engineers. Expert assistance in finding parts, usually within one business day.
4. Part number suffixes: T or T&R = tape and reel; + = RoHS/lead-free; # = RoHS/lead-exempt. More: See [full data sheet](#) or [Part Naming Conventions](#).
5. \* Some packages have variations, listed on the drawing. "PkgCode/Variation" tells which variation the product uses.

Part Number	Free Sample	Buy Direct	Package: TYPE PINS SIZE DRAWING CODE/VAR *	Temp	RoHS/Lead-Free? Materials Analysis
MAX3735E/D	<input type="checkbox"/>	<input type="checkbox"/>			RoHS/Lead-Free: <a href="#">No</a>

[Didn't Find What You Need?](#)

[CONTACT US: SEND US AN EMAIL](#)