

REVISIONS				
P	LTR	DESCRIPTION	DATE	APPV
W3	REVISED PER	ECR-15-014064	03MAR2016	NK NL

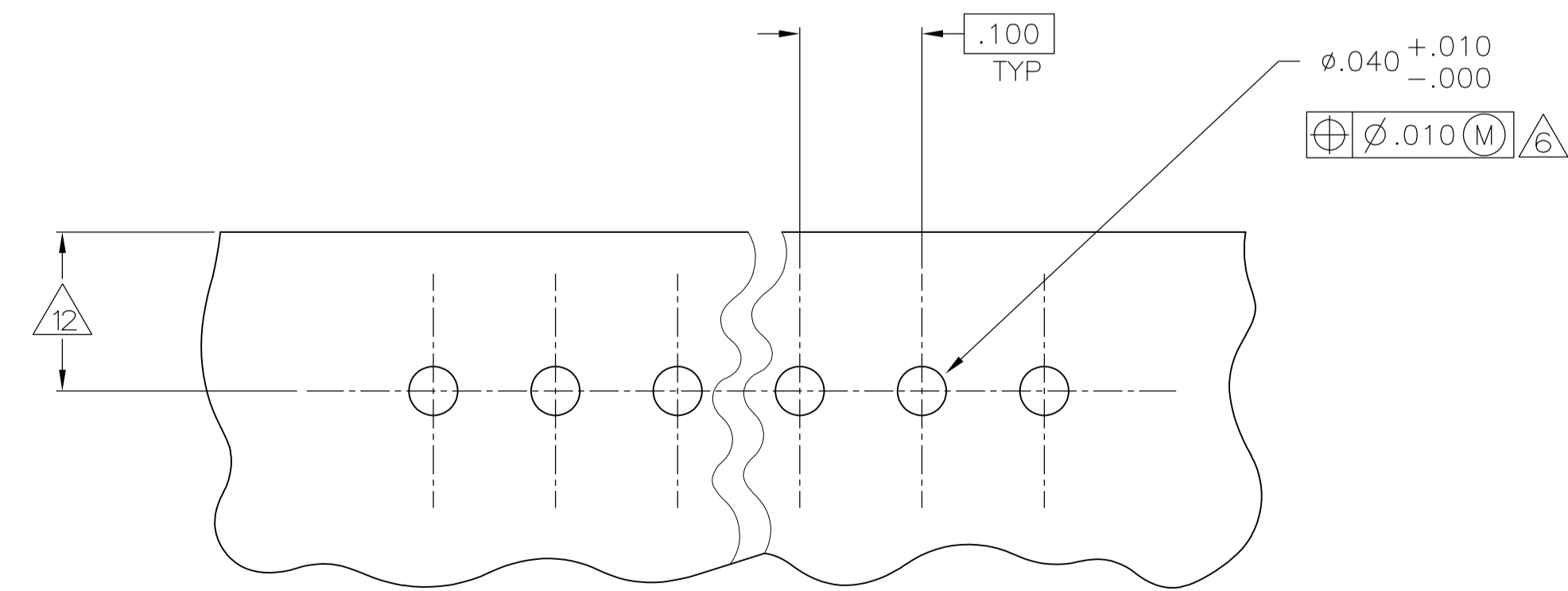
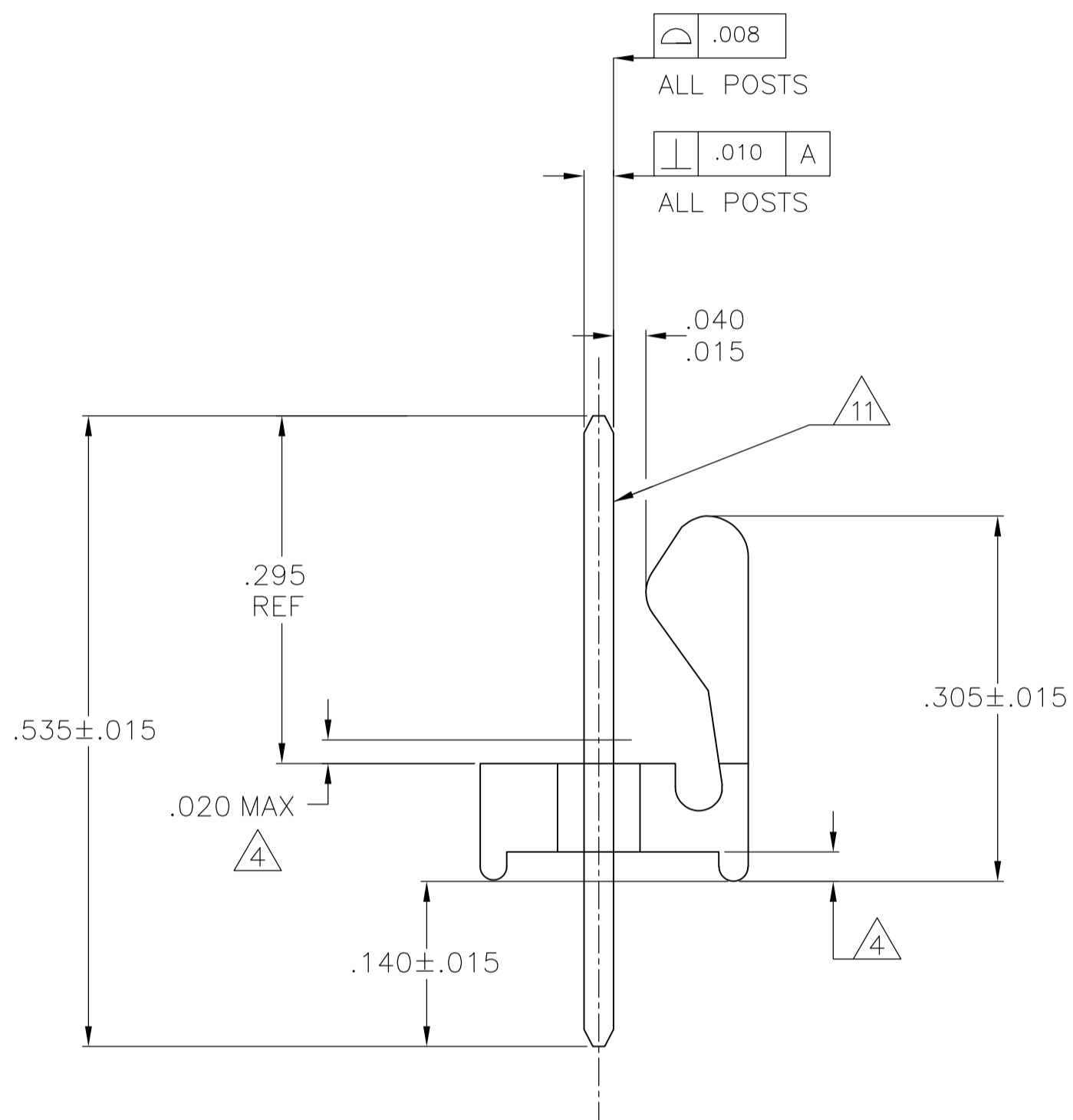
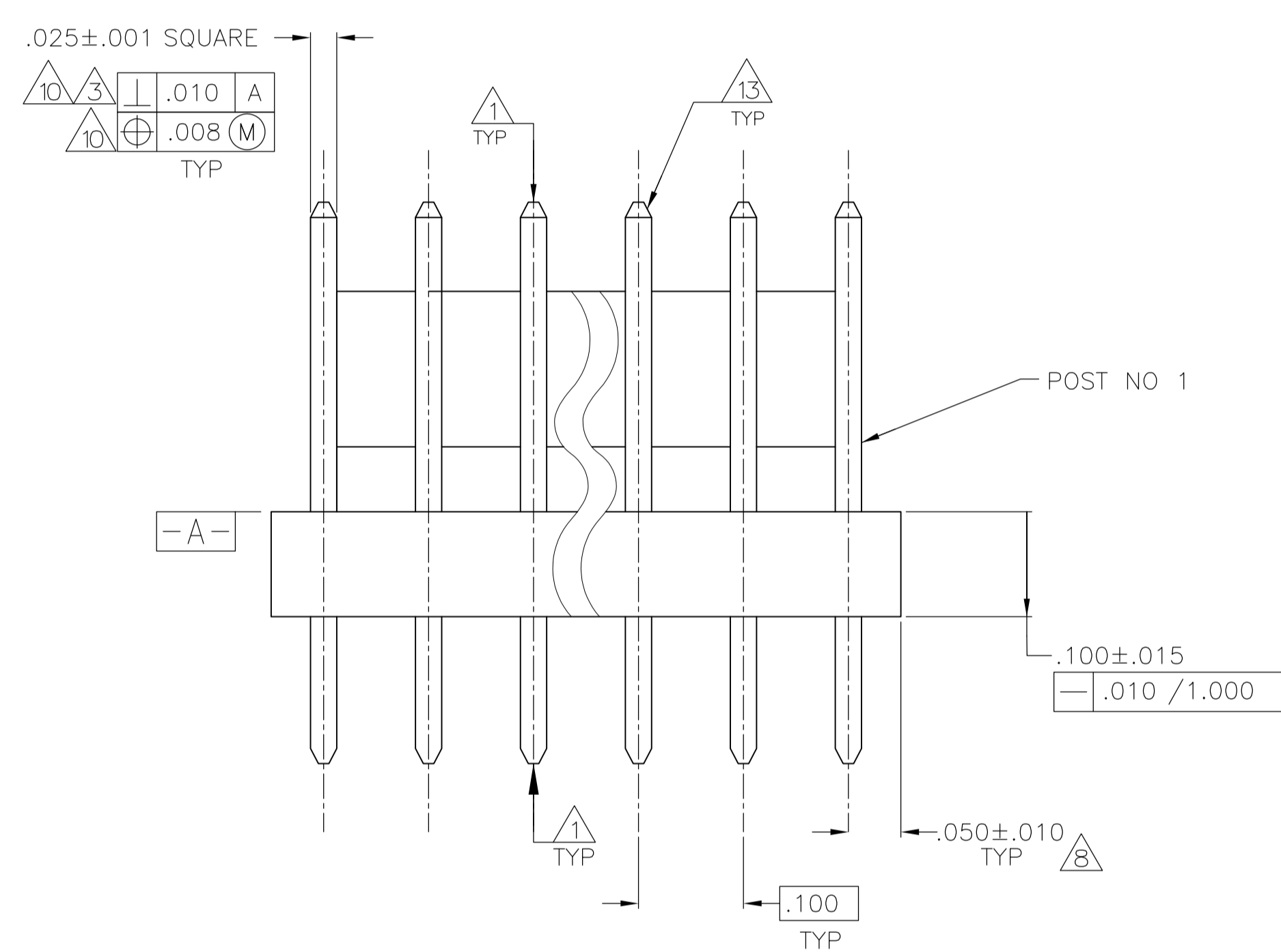
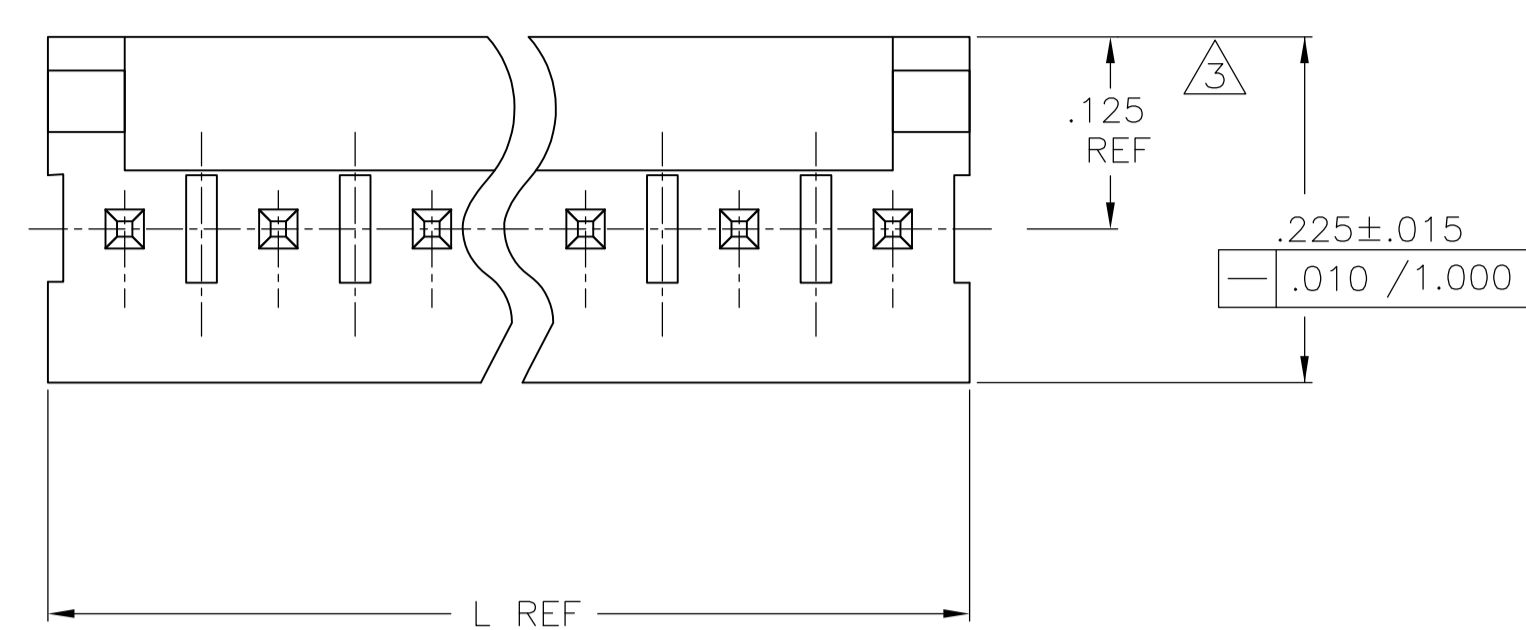

RECOMMENDED MOUNTING HOLE PATTERN FOR .063 THICK P.C. BOARD  $\triangle 2$

- $\triangle 1$  POST TO WITHSTAND 13 NEWTONS (3 LBS) MIN. AXIAL FORCE IN BOTH DIRECTIONS SHOWN WITHOUT DISLODGING.
- $\triangle 2$  TOLERANCES APPLY TO SOLDER SIDE OF BOARD.
- $\triangle 3$  MEASURED AT SURFACE  $-A-$
- $\triangle 4$  PLASTIC FLASH PERMITTED IN THIS AREA.
- 5 PARTS COMPLY WITH AMP SOLDERABILITY SPEC. NO. 109-11-2.
- $\triangle 6$  ONE HOLE MAY BE UNDERSIZED ( $\phi .032-.035$ ) FOR ASSEMBLY RETENTION DURING WAVE SOLDERING.
- $\triangle 7$  MATERIAL: HEADER-THERMOPLASTIC POLYESTER UL94V-0(NATURAL) POST-COPPER ALLOY (TIN-PLATED)
- $\triangle 8$  COORDINATE DIMENSION APPLIES FROM CENTER OF ACTUAL FEATURE.
- 9 PLASTIC BURRS CAUSED BY CUT-OFF TOOLING ARE PERMITTED WITHIN THE MAXIMUM TOLERANCE ENVELOPE.
- $\triangle 10$  POSTS TO BE MEASURED WHEN STRIP IS HELD FLAT.
- $\triangle 11$  POSTS MUST WITHSTAND TWO 90° BENDS AGAINST EXTRUSION WITHOUT BREAKING.
- $\triangle 12$  DIMENSION SHOULD BE .130 MIN WHEN MATING WITH A MTA 100 CONNECTOR ASSEMBLY OR A CST 100 CONNECTOR.
- $\triangle 13$  PIN BURR OF .005 MAX. VERTICAL AND .003 MAX. HORIZONTAL PERMITTED AT POST TIPS ON BOTH ENDS.

IN	MM	IN	MM
1.000	25.40		
.035	0.89	.535	13.59
.032	0.81	.310	7.87
.025	0.64	.295	7.49
.020	0.51	.225	5.72
.015	0.38	.140	3.56
.010	0.25	.130	3.30
.008	0.20	.125	3.18
.005	0.13	.100	2.54
.003	0.08	.063	1.60
.001	0.03	.050	1.27
.000	0.00	.040	1.02
IN	MM	IN	MM

CONVERSION TABLE

IN	MM	NO OF POSITIONS	PART NUMBER
2.800	71.12	28	2-640456-8
2.700	68.58	27	2-640456-7
2.600	66.04	26	2-640456-6
2.500	63.50	25	2-640456-5
2.400	60.96	24	2-640456-4
2.300	58.42	23	2-640456-3
2.200	55.88	22	2-640456-2
2.100	53.34	21	2-640456-1
2.000	50.80	20	2-640456-0
1.900	48.26	19	1-640456-9
1.800	45.72	18	1-640456-8
1.700	43.18	17	1-640456-7
1.600	40.64	16	1-640456-6
1.500	38.10	15	1-640456-5
1.400	35.56	14	1-640456-4
1.300	33.02	13	1-640456-3
1.200	30.48	12	1-640456-2
1.100	27.94	11	1-640456-1
1.000	25.40	10	1-640456-0
.900	22.86	9	640456-9
.800	20.32	8	640456-8
.700	17.78	7	640456-7
.600	15.24	6	640456-6
.500	12.70	5	640456-5
.400	10.16	4	640456-4
.300	7.62	3	640456-3
.200	5.08	2	640456-2
IN	MM		

THIS DRAWING IS A CONTROLLED DOCUMENT.

DIMENSIONS: INCHES	TOLERANCES UNLESS OTHERWISE SPECIFIED:	DWG NO: 11JUN2004	REV: 11JUN04
0. PLC ± -	1. PLC ± -	2. PLC ± -	3. PLC ± .005
4. PLC ANGLES ± # 0'30"			

MATERIAL:  $\triangle 7$  FINISH:  $\triangle 7$

APPROVED: D. ROSSI 11JUN04

NAME: MTA-100 HDR ASSY, POLARIZED, NOTCHED, .025 SQUARE STRAIGHT POST, TIN PLATED

SIZE: A1 CASE CODE: 00779 DRAWING NO: 640456

WEIGHT: -

CUSTOMER DRAWING SCALE: 8:1 SHEET: 1 OF 1 REV: W3