

# High Isolation Power Transformers

EP7 Platform SMD



- Push Pull Converter Transformer
- Basic insulation for isolated power supply driver
- 4.0mm Creepage
- 4KVrms Isolation (600Vrms continuous)

## Electrical Specifications @ 25°C - Operating Temperature -40°C to +125°C

Part Number	Inductance (1-3) (mH ±45%)	Leakage Inductance (µH MAX)	Capacitance (pF MAX)	DCR (1-3) (Ω MAX)	DCR (4-6) (Ω MAX)	MAX (1-3) <sup>1</sup> (V-µsec Max)	Turns Ratio (1:3) (6:4)	Isolated Voltage (Vrms)
PH9184.011NL	12.2	12.5	28.5	1.9	2.4	266	1CT : 1CT	4000
PH9184.021NL	15.0	15.0	26.5	2.1	1.4	296	2CT : 1CT	
PH9184.034NL	6.8	5.0	31.5	1.4	2.2	200	3CT : 4CT	

### Notes:

- The ET Max is calculated to limit the core loss and temperature rise at 100KHz based on a bipolar flux swing of 180mT Peak.
- For Push-Pull topology, where the voltage is applied across half the primary winding turns, the ET needs to be derated by 50% for the same flux swing.
- The applied ET may need to be further derated for higher frequencies based on the temperature rise which results from the core and copper losses.
  - To calculate total copper loss (W), use the following formula:  

$$\text{Copper Loss (W)} = I_{rms\_Primary}^2 * DCR\_Primary + I_{rms\_Secondary}^2 * DCR\_Secondary$$
  - To calculate total core loss (W), use the following formula:  

$$\text{Core Loss (W)} = 4.40E-10 * (\text{Frequency in kHz})^{1.67} * (180 * [ET/ET Max])^{2.53}$$
- Optional Tape & Reel packing can be ordered by adding a "T" suffix to the part number (i.e. PH9184.011NL becomes PH9184.011NLT). Pulse complies to industry standard tape and reel specification EIA481.
- The "NL" suffix indicates an RoHS-compliant part number.
- The temperature of the component (ambient plus the temperature rise) must be within the stated operating temperature range.

Where ET is the applied Volt Second, ET Max is the rated Volt Second for 180mT flux swing

C. To calculate temperature rise, use the following formula:  
 Temperature Rise (°C) = 90 \* (Core Loss(W) + Copper Loss (W))

## Mechanical

## Schematic

### PH9184.XXXXNL

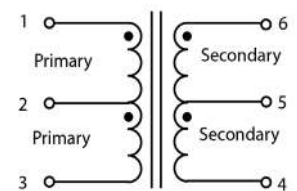
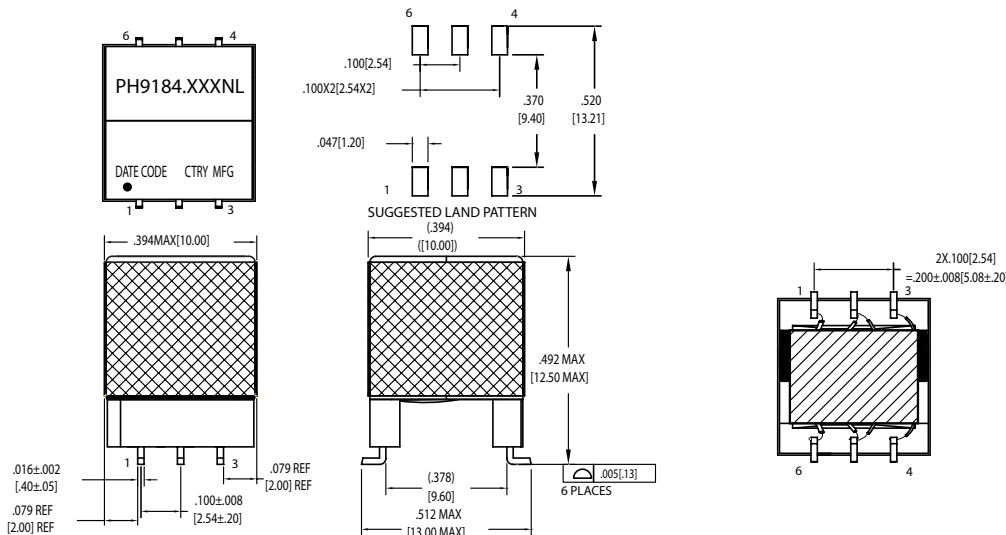

Weight .....2.6grams  
 Tape & Reel .....150/reel  
 Tray .....80/tray

Dimensions:  $\frac{\text{Inches}}{\text{mm}}$

Unless otherwise specified, all tolerances are ±  $\frac{.010}{0.25}$

## Application

PH9184NL is a series of high isolation power supply transformer drivers. Intended to operate in a fixed duty cycle Push Pull topology, it is a part of a low cost solution for delivering lower power (up to 3W) from a low voltage source. A typical implementation would be an isolated RS-485/RS-232 power supply driver circuit, the design is compatible with the MAXIM™ MAX253 IC.

A schematic diagram for the Push Pull converter topology is given below.

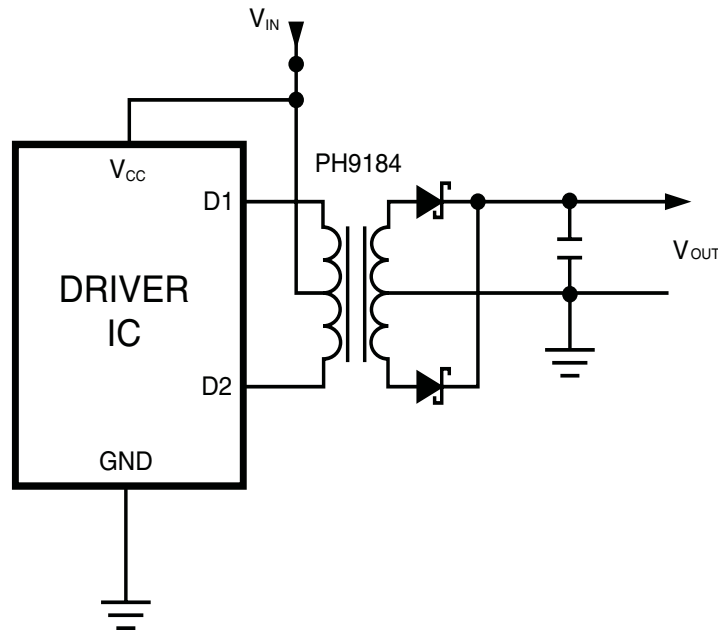

For a fixed 50% duty cycle mode of operation, the output voltage is simply determined by the input voltage and turns ratio. So, with the available turns ratios, a variety of output voltages can be selected.

This transformer design conforms to UL60950-1 2 edition with basic insulation for a working voltage up to 300Vac. 3.2mm creepage and 3000Vrms isolation voltage is guaranteed to meet this requirement. The actual isolation and creepage capability of the design exceeds these UL ratings.

MAXIM is a registered trademark of Maxim Integrated Products.

## For More Information

### Pulse Worldwide Headquarters

15255 Innovation Drive Ste 100  
San Diego, CA 92128  
U.S.A.

Tel: 858 674 8100  
Fax: 858 674 8262

### Pulse Europe

Pulse Electronics GmbH  
Am Rottland 12  
58540 Meinerzhagen  
Germany

Tel: 49 2354 777 100  
Fax: 49 2354 777 168

### Pulse China Headquarters

Pulse Electronics (ShenZhen) CO., LTD  
D708, Shenzhen Academy of  
Aerospace Technology,  
The 10th Keji South Road,  
Nanshan District, Shenzhen,  
P.R. China 518057

Tel: 86 755 33966678  
Fax: 86 755 33966700

### Pulse North China

Room 2704/2705  
Super Ocean Finance Ctr.  
2067 Yan An Road West  
Shanghai 200336  
China

Tel: 86 21 62787060  
Fax: 86 2162786973

### Pulse South Asia

3 Fraser Street  
0428 DUO Tower  
Singapore 189352

Tel: 65 6287 8998  
Fax: 65 6280 0080

### Pulse North Asia

1F., No.111 Xiyuan Rd  
Zhongli City  
Taoyuan City 32057  
Taiwan (R.O.C)

Tel: 886 3 4356768  
Fax: 886 3 4356820

Performance warranty of products offered on this data sheet is limited to the parameters specified. Data is subject to change without notice. Other brand and product names mentioned herein may be trademarks or registered trademarks of their respective owners. © Copyright, 2019. Pulse Electronics, Inc. All rights reserved.