

used for: D-SUB HD FILTER

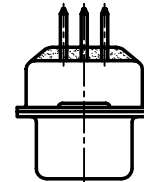
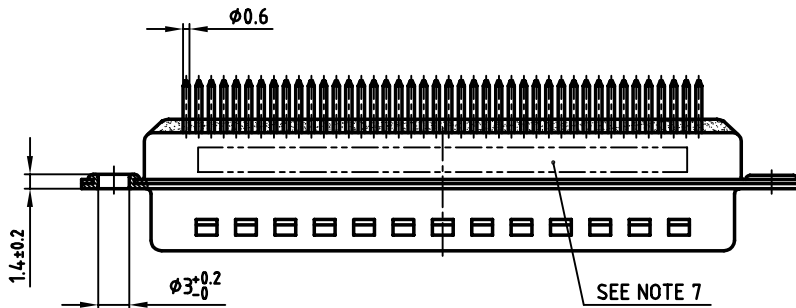
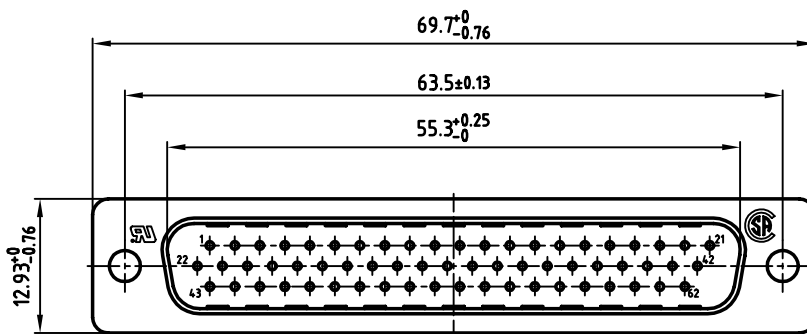
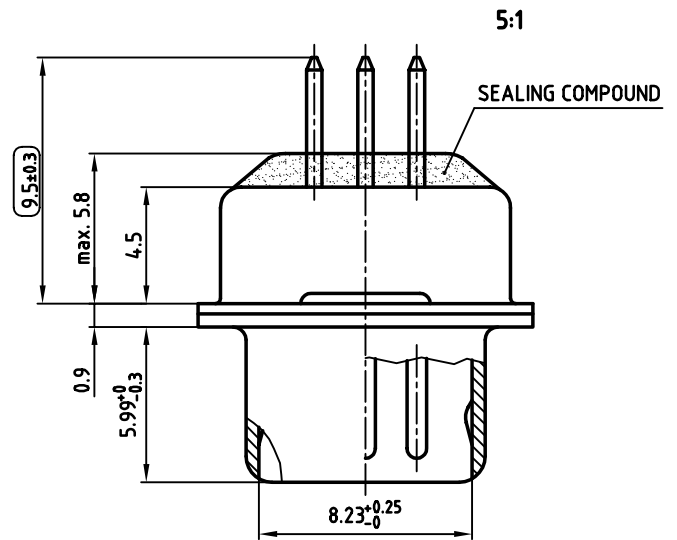

NOTES:

1. METALSHELLS: STEEL; min. 320µ" TIN
2. INSULATORS: PBT GF UL 94 V-0, BLACK
3. CONTACTS: COPPER ALLOY
PLATING: 8µ" HARD GOLD OVER min. 50µ" NICKEL
4. P.C.B. HOLE DRILLINGS ON DRAWING NO.: 16V1IH5B
5. CAPACITANCE: SEE TABLE
6. DIELECTRIC WITHSTANDING VOLTAGE: 300V DC
7. CONNECTOR IS PART MARKED: [PART-NO. CONEC Y/WW]
8. = CHECK DIMENSION

| CAPACITANCE | PART NO. |
|-------------|-------------------|
| 180pF ±20% | 241A27510X |
| 370pF ±20% | 241A16410X |
| 830pF ±20% | 241A16450X |

APPROVAL * FREIGABE * DEBLOCAGE * AUTORIZACION * APPROVAL

CUSTOMER APPROVAL DATE:

NAME: TITLE:

COMPANY NAME:

APPROVAL * FREIGABE * DEBLOCAGE * AUTORIZACION * APPROVAL

THIS DRAWING MAY NOT BE COPIED OR REPRODUCED IN ANY WAY, AND MAY NOT BE PASSED ON TO A THIRD PARTY, WITHOUT WRITTEN PERMISSION. OWNERSHIP AND COPYRIGHT OF CONEC GmbH DO NOT ALTER CAD DRAWING BY HAND

| rev. | description | date | name |
|------|-------------|------|------|
| | | | |
| | | | |
| | | | |
| | | | |

| | | | |
|--------------|------------|--------------|-----------------------------|
| tolerance | | scale: | 2:1 (5:1) |
| | dim. in mm | material: | SEE NOTES |
| 2003 | date | name | title: |
| drawn | 16.09. | Lehnenkühler | D-SUB HD FILTER MALE |
| appd. | 19.09. | Mickenbecker | 62pos. SOLDER PIN STRAIGHT |
| norm | DIN 41652 | | dwg no: |
| d-old | | | AutoCAD 2000 |
| CONEC | | part no: | 24K1A448 |
| | | SEE TABLE | DIN-A |
| | | | 3 |
| | | | sh: 1/1 |

| | | |
|----------|-----------------|---------|
| dwg no: | AutoCAD 2000 | DIN-A |
| part no: | 24K1A448 | 3 |
| | SEE TABLE | sh: 1/1 |