

## ZSSC4132KIT

### Evaluation Kit Description

#### Description

The ZSSC4132 Evaluation Kit is designed to support customer in evaluation, initial laboratory setup and development of calibration procedure for ZSSC4132 Sensor Signal Conditioner (SSC).

To support the above tasks, the single IC in 24-QFN socket can be used or a user's sensor module can be connected to the kit. The kit also includes a sensor replacement board that can be used in place of an actual sense element for basic evaluation purposes only.

The main purpose of the ZSSC4132 Evaluation Kit is to provide a communication interface to the IC. Those the ZSSC4132 evaluation board is controlled by the microcontroller board "SSC Communication Board" (included in the kit).

This will be connected via USB to the computer and controlled by PC-software via a graphical user interface.

#### Features

- USB 2.0 compatible "Plug & Play" connection between the user's computer and Evaluation Kit board for communication
- Communication interface enables configuration, calibration, and performance evaluation
- Powered by USB port or an external power supply (8V to 16V)
- Internal generated 12VDC and 5VDC supply
- Providing LIN (v1.3 and v2.x) and I2C communication to IC
- Sensor replacement board for quick and easy first IC feature evaluation
- Software is available for download from website: [www.IDT.com/ZSSC4132](http://www.IDT.com/ZSSC4132)

#### Kit Contents

- SSC Communication Board (SSC-CB)
- ZSSC4132 Evaluation Board (SSC-EVB)
- SSC Sensor Replacement Board (SSC-SRB)
- ZSSC4132 24-QFN Sample Board
- USB (type B) connection cable
- 5 samples ZSSC4132 (24-QFN; 4 x 4 mm)
- Tweezers (provided for safe handling)
- Quick Start Guide with link to GUI software

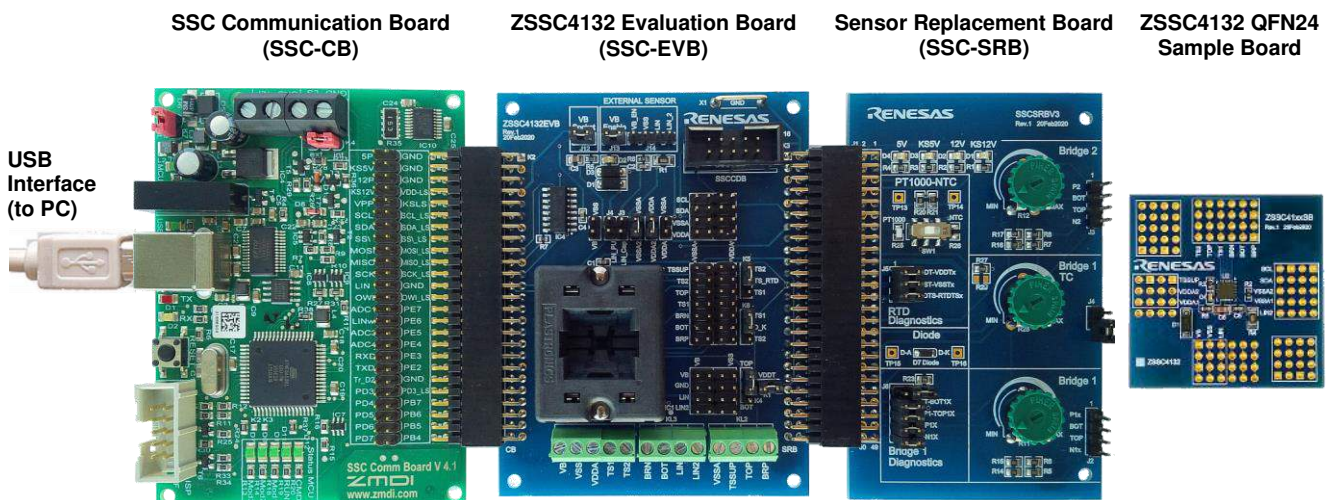

Figure 1. ZSSC4132 Evaluation Kit

**Important Notes****Disclaimer**

Renesas Corporation and its affiliated companies (herein referred to as “Renesas”) shall not be liable for any damages arising out of defects resulting from

- (i). delivered hardware or software
- (ii). non-observance of instructions contained in this manual and in any other documentation provided to user, or
- (iii). misuse, abuse, use under abnormal conditions, or alteration by anyone other than Renesas.

TO THE EXTENT PERMITTED BY LAW, RENESAS HEREBY EXPRESSLY DISCLAIMS AND USER EXPRESSLY WAIVES ANY AND ALL WARRANTIES, WHETHER EXPRESS, IMPLIED, OR STATUTORY, INCLUDING, WITHOUT LIMITATION, IMPLIED WARRANTIES OF MERCHANTABILITY AND OF FITNESS FOR A PARTICULAR PURPOSE, STATUTORY WARRANTY OF NON-INFRINGEMENT, AND ANY OTHER WARRANTY THAT MAY ARISE BY REASON OF USAGE OF TRADE, CUSTOM, OR COURSE OF DEALING.

**Restrictions in Use**

Renesas’s ZSSC4132 Evaluation Kit, consisting of the SSC Communication Board, SSC Board ZSSC4132, Sensor Replacement Board, and ZSSC4132 GUI software, is designed for sensor module evaluation, laboratory setup, and module calibration development only. Renesas’s SSC Evaluation Kit hardware and software must not be used for qualification, module production or production test setups, or any other use not expressly authorized herein.



**Important Equipment Warning:** Ensure the correct connection of all cables. Ensure the correct connection of the board-to-board pin connectors. Ensure the correct position of the IC in the socket. Supplying the board and/or IC using the wrong polarity could result in damage to the IC, board and/or the equipment. Check that all jumpers have been set properly before applying power.

Only trained professional staff should connect the equipment and operate the software.

## Contents

<b>1. Setup</b> .....	<b>6</b>
1.1 Required or Recommended User Equipment .....	6
1.2 User Computer Requirements and Setup .....	6
1.2.1. Computer Requirements .....	6
1.2.2. Software Installation and Setup .....	6
1.3 Kit Hardware Connections .....	7
1.4 External Equipment Connections .....	12
1.5 Power-up and Connection Procedure .....	12
<b>2. User Guide</b> .....	<b>15</b>
2.1 General GUI Handling and Settings .....	15
2.1.1. Saving and Loading the GUI Configuration File (.cfgx) .....	15
2.2 Saving and Loading an IC Memory Dump .....	16
2.2.1. Saving IC Memory Data .....	16
2.2.2. Loading RAM Shadow Data .....	16
2.2.3. Writing the Memory Content to the IC .....	17
2.3 IC Configuration and Calibration Procedures .....	17
2.3.1. "CONFIGURE" Application Tab .....	17
2.3.2. "CALIBRATION" Application Tab .....	19
2.4 Evaluation Procedures .....	28
2.4.1. "MAIN" Application Tab .....	28
2.4.2. "IC STATUS" Section .....	29
2.4.3. "Normal Mode" Window .....	30
2.5 "Command Console" Tab .....	30
2.5.1. I2C Commands (Example) .....	32
2.5.2. LIN Commands (Example) .....	33
2.5.3. Command Script (Example) .....	38
2.6 "MEMORY EDIT" Application Tab .....	39
2.7 Tools .....	40
2.8 Help .....	40
<b>3. Schematics</b> .....	<b>41</b>
<b>4. Bill of Materials (BOM)</b> .....	<b>43</b>
<b>5. Board Layout</b> .....	<b>46</b>
<b>6. Related Documents and Software Locations</b> .....	<b>47</b>
<b>7. Glossary</b> .....	<b>47</b>
<b>8. Ordering Information</b> .....	<b>48</b>
<b>9. Revision History</b> .....	<b>48</b>

## Figures

Figure 1. ZSSC4132 Evaluation Kit .....	1
Figure 2. Initial Display of the Evaluation Software (No Board Connected) .....	7
Figure 3. Default Evaluation Kit Connections .....	8
Figure 4. ZSSC4132 Evaluation Board (ZSSC4132EVB Rev. 1) – Overview .....	9
Figure 5. Sensor Replacement Board (SSCSR3 Rev.1) – Overview .....	10
Figure 6. Evaluation Kit Connections Example 2: Connecting External Resistive Sensor Bridge .....	10
Figure 7. Evaluation Kit Connections Example 3: Connecting External Sensor Including SSC .....	11
Figure 8. Evaluation Kit Connections Example 4: External 12V Supply via SSC-CB .....	11
Figure 9. Evaluation Kit Connections Example 5: Connect sample PCB + External Sensor Bridge .....	12
Figure 10. Initial Display Explained (Evaluation Kit properly connected to USB; IC not activated) .....	13
Figure 11. Settings Menu.....	13
Figure 12. Initial Display after Evaluation Kit and IC Properly Connected .....	14
Figure 13. Evaluation Kit – IC connected – Status of Power Indicators .....	14
Figure 14. Loading the GUI Configuration File .....	15
Figure 15. Save Configuration Dialog Window at Closing.....	15
Figure 16. Save the Memory Data to a File .....	16
Figure 17. Load the RAM Shadow Data into GUI .....	16
Figure 18. Memory Indicator: Same Content.....	17
Figure 19. Memory Indicator: Modified Content .....	17
Figure 20. Writing the Configuration into the RAM Shadow and NVM.....	17
Figure 21. CONFIGURE Tab.....	18
Figure 22. CALIBRATION/"BRIDGE-SENSOR" Sub-tab – Calibration Procedure.....	19
Figure 23. "TEMPERATURE 1" Sub-tab – Calibration type: Quadratic .....	21
Figure 24. IC Settings for PT1000 Setup (Configure Pin TS1 and TS2, Measurement Uses Pin TS1).....	22
Figure 25. PTC Setup on SSC-EB and SSC-SRB (PT1000 Measured at TS1) .....	22
Figure 26. "TEMPERATURE 1" Sub-Tab – Calibration Type: PTC .....	23
Figure 27. IC Settings for NTC (Configure Pin TS1 and TS2, Measurement Uses Pin TS1) .....	24
Figure 28. NTC Setup on SSC-EB and SSC-SRB (NTC Measured at TS1) .....	24
Figure 29. "TEMPERATURE 1" – Calibration Type: NTC.....	25
Figure 30. "TEMPERATURE 2" Sub-Tab – Calibration Type: Quadratic.....	26
Figure 31. "BRIDGE SENSOR CHECK" Sub-Tab – Wire Break and Short Detection with Temperature Compensation.....	27
Figure 32. Measurement Readings on "MAIN" Tab .....	28
Figure 33. IC STATUS Panel.....	29
Figure 34. LIN Publisher Frame Output in "Normal Mode" Window.....	30
Figure 35. "COMMAND CONSOLE" Tab .....	31
Figure 36. Memory Indicator: Modified Content .....	39
Figure 37. "MEMORY EDIT" Tab – Shadow Memory .....	39
Figure 38. "MEMORY EDIT" Tab – Output Memory (Decimal).....	40
Figure 39. TOOLS Menu Options .....	40
Figure 40. HELP Menu Options.....	40
Figure 41. Schematic – ZSSC4132 Evaluation Board: ZSSC4132EVB_Rev.1 (20Feb2020) .....	41
Figure 42. Schematic – ZSSC4132 Sample Board: ZSSC41xxSB_Rev.1 (20Feb2020); Bottom (ZSSC4132) ....	41
Figure 43. Schematic – Sensor Replacement Board: SCSR3_Rev.1 (20Feb2020).....	42

---

Figure 44. Layout - ZSSC4132 Evaluation Board: ZSSC4132EVB, Rev.1, 20Feb2020 – Top/Bottom Layer.....	46
Figure 45. Layout - Sensor Replacement Board: SSCSRBV3, Rev.1, 20Feb2020 – Top/Bottom Layer .....	46
Figure 46. Layout - ZSSC4132 Sample Board: ZSSC41xxSB, Rev.1, 20Feb2020 – Bottom Layer ZSSC4132...	46

## Tables

Table 1. Evaluation Kit Connection and Jumper Descriptions (Default Setup) .....	8
Table 2. Sensor Replacement Board (SSCSR BV3 Rev.1) – Indicator, Jumper and Connector Descriptions .....	9
Table 3. Sensor Replacement Board (SSCSR BV3 Rev.1) – Indicator and Jumper Descriptions .....	10
Table 4. Sub-tabs of the “CONFIGURE” Tab .....	18
Table 5. Bridge Sensor - Calibration Type Settings .....	20
Table 6. Bridge Sensor Calibration - Acquisition Settings.....	20
Table 7. Bridge Sensor Check – Diagnostic Levels and Calibration Procedures .....	27
Table 8. MAIN Tab – Measurement Readings .....	28
Table 9. Command Console – General Setup Commands .....	31
Table 10. Command Console – I2C Commands (Example) .....	32
Table 11. Command Console – LIN Commands (Example) .....	33
Table 12. BOM - ZSSC4132 Evaluation Board: ZSSC4132EVB, Rev.1, 20Feb2020 .....	43
Table 13. BOM – Sensor Replacement Board: SSCSR BV3, Rev.1, 20Feb2020 .....	44
Table 14. BOM – ZSSC4132 Sample Board: ZSSC41xxSB, Rev.1, 20Feb2020 – Bottom Layer (ZSSC4132) ...	45

## 1. Setup

### 1.1 Required or Recommended User Equipment

A Windows®-based computer with free USB-port is required for interfacing with the kit. The kit can be powered by the USB port.

The following lab equipment can be alternatively used to power the kit and IC:

- Power supply: 8V to 16V; current capability >100mA; over current/short circuit protected supply is recommended

### 1.2 User Computer Requirements and Setup

#### 1.2.1. Computer Requirements

A Windows®-based computer is required for interfacing with the kit and configuring the part.

The computer must meet the following requirements:

- Windows® 7 / Windows® 8 / Windows® 10
- Microsoft .NET Framework 4 or higher
- Supported architecture: x86 and x64
- Available USB port

The user must have administrative rights on the computer to download and install the Evaluation Software for the kit.

#### 1.2.2. Software Installation and Setup

The zip format of the latest revision of ZSSC4132 Evaluation Software (GUI), which is required for the kit, must be downloaded from the web site at [www.IDT.com/ZSSC4132](http://www.IDT.com/ZSSC4132).

Note: FTDI USB drivers are needed for communication with the SCC Communication Board. If these drivers are not already installed on the user's computer, the software automatically installs the correct drivers after user confirmation.

Follow these procedures to install the Evaluation Kit Software on the user's computer:

1. Download and extract the contents of the zip file to the user's computer.
2. Double click on the extracted *setup.exe* file.
3. Follow the resulting standard installation instructions displayed on the screen, altering the installation path if needed. If the default path settings is used, the software automatically completes the installation and creates an access link on the user's computer under *Start > Renesas > ZSSC4132C*.  
The installation dialog offers the option to create a desktop shortcut icon for the software if selected.
4. Connect the kit hardware as described in section 1.3 before starting the software program for the first time.
5. Read License Terms and Conditions of the software and check "I agree to the Terms and Conditions" in order to proceed.

Figure 2 shows the initial display of the software when it is started.

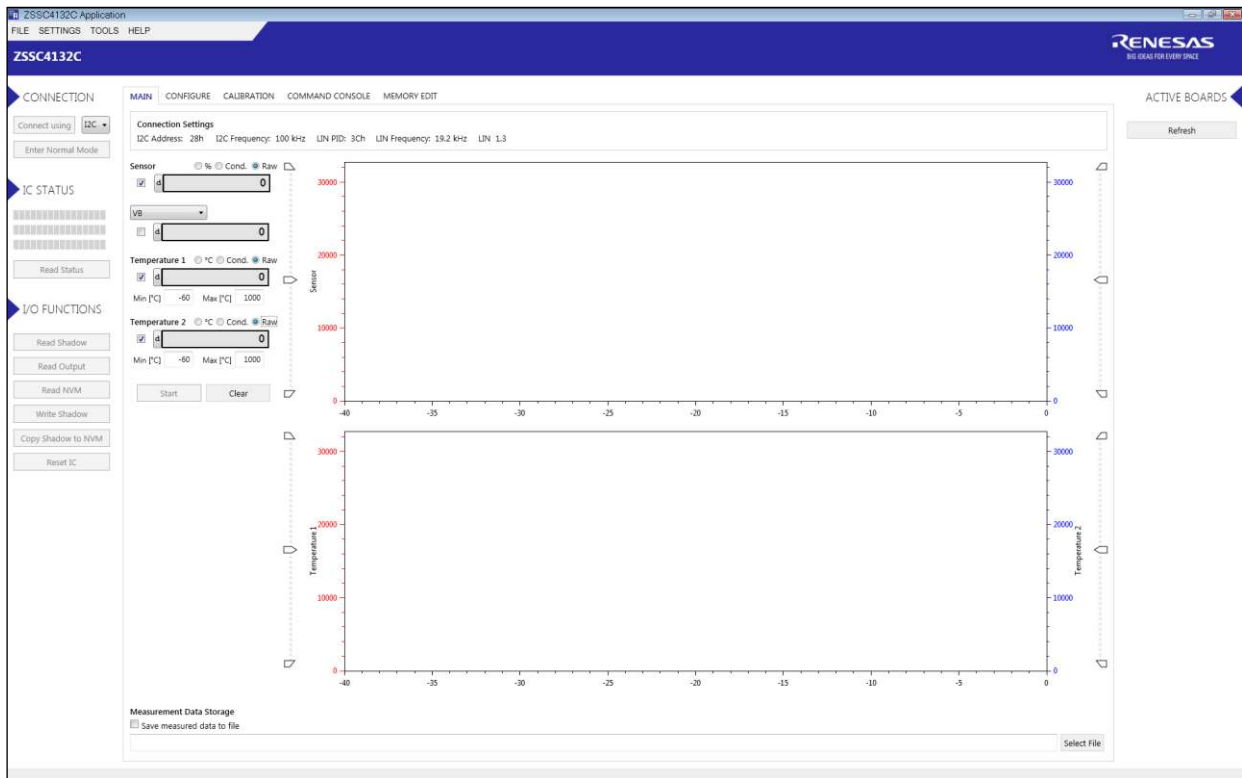

Figure 2. Initial Display of the Evaluation Software (No Board Connected)

### 1.3 Kit Hardware Connections

The ZSSC4132 Evaluation Kit contains the hardware needed for communication and application of the ZSSC4132 sensor signal conditioning ICs. The user can run the software to communicate with the ZSSC4132 DUT via the SSC Communication Board connected to the user's computer by a USB cable.

The Evaluation Kit hardware consists of the following three boards as shown in Figure 3 and includes samples of the ZSSC4132 (24-QFN):

- SSC Communication Board – Connects to computer through a USB 2.0 cable and handles the I2C (trademark of NXP) and LIN interface communication between the PC-based software and the ZSSC4132. For detailed description please see also check on web site: [www.IDT.com/SSC-CB](http://www.IDT.com/SSC-CB)
- ZSSC4132 Evaluation Board – This board contains a 24-QFN socket for the ZSSC4132 single IC, access points for connection to instrumentation, and an external sensor circuitry/module. See Figure 3 for the location of pin 1 for proper IC orientation. Install jumpers initially as shown in Figure 3. This board also offers a connector to a Sensor Replacement Board.
- Sensor Replacement Board – This board provides equivalent input signals for easy evaluation of functionality without an actual sensor bridge or stimulus. Remove it when connecting a real external sense element.

Note: There is a “dummy” IC in the socket on the SSC Board ZSSC4132 that has to be replaced with an actual ZSSC4132 device under test (DUT). See Figure 3 for the location of pin 1 for proper IC orientation.

Follow these procedures to set up the kit as shown in Figure 3:

1. Connect the SSC Communication Board, the ZSSC4132 Evaluation Board, and the SSC Sensor Replacement Board via board-to-board connectors as shown in Figure 3
2. Insert IC into the 24-QFN socket; see Figure 3 for the location of pin 1 for proper IC orientation.
3. Connect SSC Communication Board via USB cable to the user's computer.



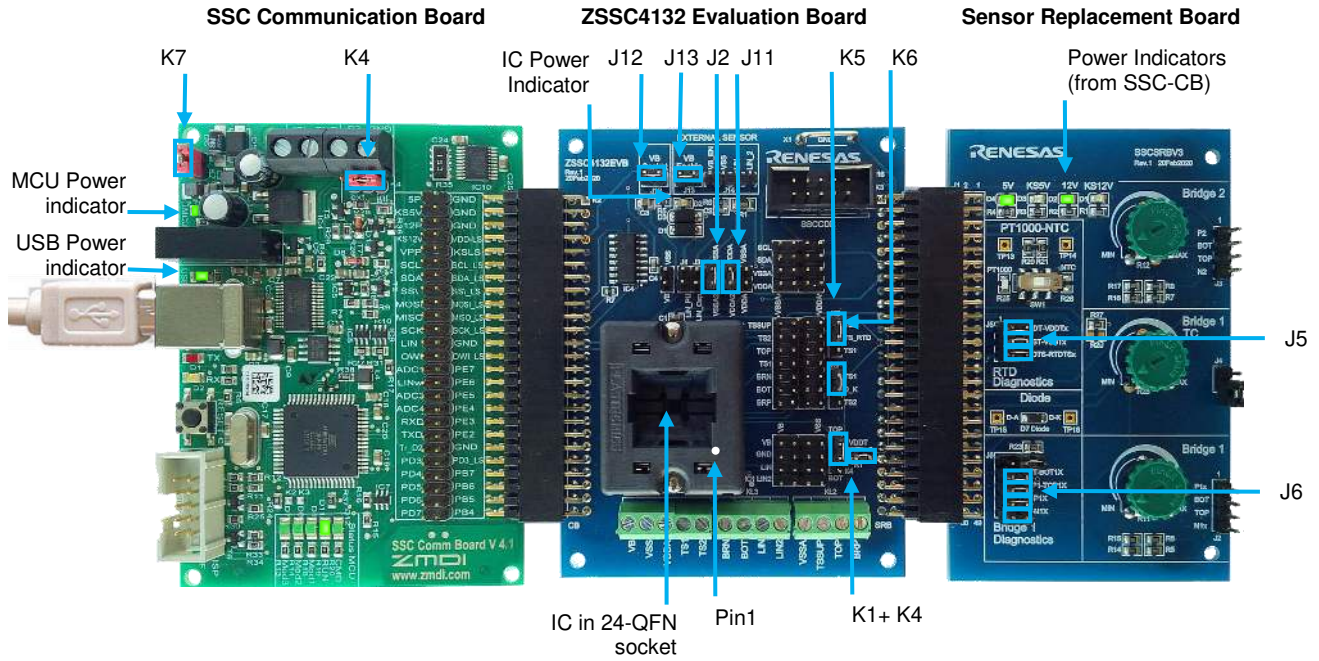

Figure 3. Default Evaluation Kit Connections

Table 1. Evaluation Kit Connection and Jumper Descriptions (Default Setup)

Board	Connector	Type	Description
SSC-CB	K7	2-Pin Header – Male	“enable 12P int.” – Set jumper to enable on-board generated 12VDC supply.
SSC-CB	K4	3-Pin Header – Male	Set jumper to “int.” for selecting internal power source (default configuration) for VDD-LS supplies (1.8 V, 3.3 V).
SSC-CB / SSC-EB	K1 / K2	50-Pin Board Connector	Bi-directional connection from SSC Communication Board to ZSSC4132 Evaluation Board.
SSC-EB	J12	2-Pin Header – Male	Set jumper to connect the “KS12V” (the switched 12VDC supply) from SSC communication board to the QFN socket. The proper VB supply is indicated by LED D2.
SSC-EB	J12	2-Pin Header – Male	Set jumper to connect the “KS12V” (the switched 12VDC supply) from SSC communication board to the “External Sensor” connector J14
SSC-EB	J11	2-Pin Header – Male	Set jumper to connect VDDA and VDDA2 (required to be shorted for proper operation).
SSC-EB	J2	2-Pin Header – Male	Set jumper to connect VSSA and VSSA2 (required to be shorted for proper operation).
SSC-EB / SSC-SRB	K3 / J1	50-Pin Board Connector	Bi-directional connection from ZSSC4132 Evaluation Board to Sensor Replacement Board.
SSC-EB	K5	3-Pin Header – Male	Set jumper to connect TS1 or TS2 pin to external resistive temperature sense element on Sensor Replacement Board (TS_RTD).
SSC-EB	K6	3-Pin Header – Male	Set jumper to connect TS1 or TS2 pin to cathode of external diode temperature sense element on Sensor Replacement Board (D_K).
SSC-EB	K4 K1	3-Pin Header – Male 2-Pin Header - Male	Set both jumper to provide reference supply (VDDT) to resistive temperature sense half-bridge on Sensor Replacement Board (TS_RTD).
SSC-SRB	SW1	Switch	Switch to select PTC (PT1000) or NTC for external TS_RTD sense element.
SSC-SRB	J5	3x2-Pin Header - Male	Set jumpers (pins 1-2, 3-4, 5-6) to connect RTD sense element to J1 board connector.
SSC-SRB	J6	5x2-Pin Header - Male	Set jumpers (pins 1-2, 3-4, 5-6, 7-8) to connect Bridge 1 sense element to J1 board connector. Note: disconnect jumper (pins 9-10, P1-N1) to remove short of P1-N1!



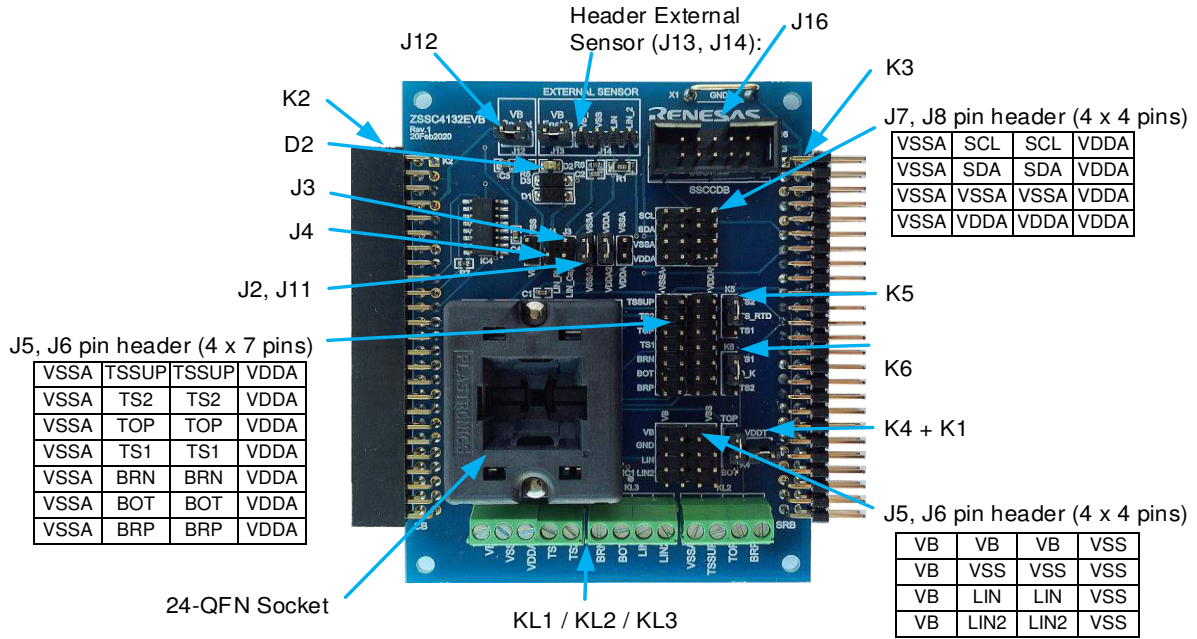
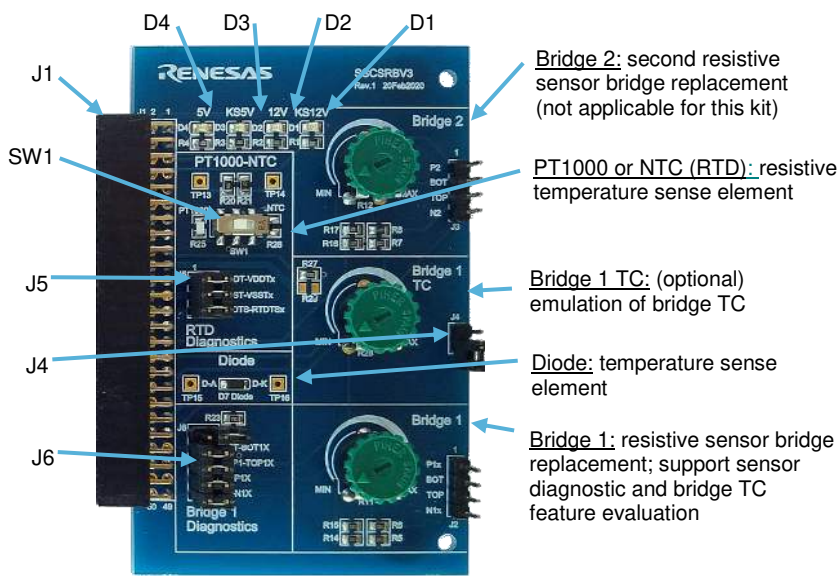

Figure 4. ZSSC4132 Evaluation Board (ZSSC4132EVB Rev. 1) – Overview

Table 2. Sensor Replacement Board (SSCSRBV3 Rev.1) – Indicator, Jumper and Connector Descriptions

Element	Type	Description
D2	LED	Indicator for status of the switched 12V supply (“KS12V”) from SSC-CB; IC supply
J2	2-Pin Header – Male	Set jumper to connect VSSA and VSSA2 (required to be shorted for proper operation).
J3	2-Pin Header – Male	Set jumper to enable additional capacitance of 220pF between LIN and GND
J4	2-Pin Header – Male	To connect a custom pull-up resistor between LIN and KS12V (VB supply)
J5, J6	4x7-Pin Header - Male	Provide access to pins: TSSUP, TS2, TOP, TS1, BRN, BOT, BRP, VSSA, VDDA
J7, J8	4x4-Pin Header - Male	Provide access to pins: SCL, SDA, VSSA, VDDA
J11	2-Pin Header – Male	Set jumper to connect VDDA and VDDA2 (required to be shorted for proper operation).
J12	2-Pin Header – Male	Set jumper to connect the “KS12V” (the switched 12VDC supply) from SSC communication board to the QFN socket. The proper VB supply is indicated by LED D2.
J13	2-Pin Header – Male	Set jumper to connect the “KS12V” (the switched 12VDC supply) from SSC communication board to the “External Sensor” connector J14
J14	4-Pin Header – Male	To optional connect an external sensor module; providing signals: VB, GND, LIN and LIN_2
J16	2x5-Pin Box Header - Male	SSCCDB connector
K2	50-Pin Socket	Bi-directional board connection to SSC Communication Board
K3	50-Pin Header - Male	Bi-directional board connection to Sensor Replacement Board
K5	3-Pin Header – Male	Set jumper to connect TS1 or TS2 pin to external resistive temperature sense element on Sensor Replacement Board (TS_RTD).
K6	3-Pin Header – Male	Set jumper to connect TS1 or TS2 pin to cathode of external diode temperature sense element on Sensor Replacement Board (D_K).
K4, K1	3-Pin Header – Male 2-Pin Header - Male	Set both jumper to provide reference supply (VDDT) to resistive temperature sense half-bridge for NTC/ PT1000 on Sensor Replacement Board (TS_RTD).
KL1, KL2, KL3	Screw Terminals	Screw terminals for optional connection to external supply and sensor bridges



Bridge 2:

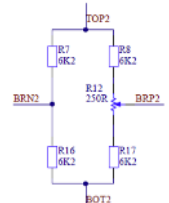

Bridge 1 + Bridge 1 TC:

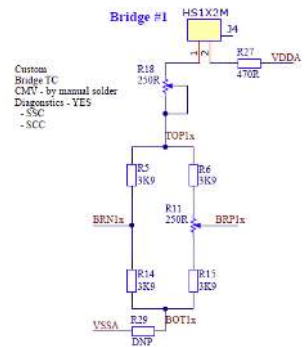

Figure 5. Sensor Replacement Board (SSCSR BV3 Rev.1) – Overview

Table 3. Sensor Replacement Board (SSCSR BV3 Rev.1) – Indicator and Jumper Descriptions

Element	Type	Description
D1	LED	Indicator for status of the switched 12V supply (“KS12V”) from SSC-CB
D2	LED	Indicator for status of the permanent 12V supply (“12P”) from SSC-CB
D3	LED	Indicator for status of the switched 5V supply (“KS5V”) from SSC-CB
D4	LED	Indicator for status of the permanent 5V supply (“5P”) from SSC-CB
J1	50-Pin Board Connector	Bi-directional connection to ZSSC4132 Evaluation Board
J4	2-Pin Header – Male	Set this optional jumper to enable “Bridge 1 TC” functionality. (default = open)
J5	3x2-Pin Header - Male	Set jumpers (pins 1-2, 3-4, 5-6) to connect RTD sense element to J1 board connector. It can be used to evaluate RTD diagnostic features.
J6	5x2-Pin Header - Male	Set jumpers (pins 1-2, 3-4, 5-6, 7-8) to connect Bridge 1 sense element to J1 board connector. It can be used to evaluate bridge sensor diagnostic features. Note: disconnect jumper (pins 9-10, P1-N1) to remove short of P1-N1!
SW1	Switch	Switch to select PTC (PT1000) or NTC for TS_RTD sense element.

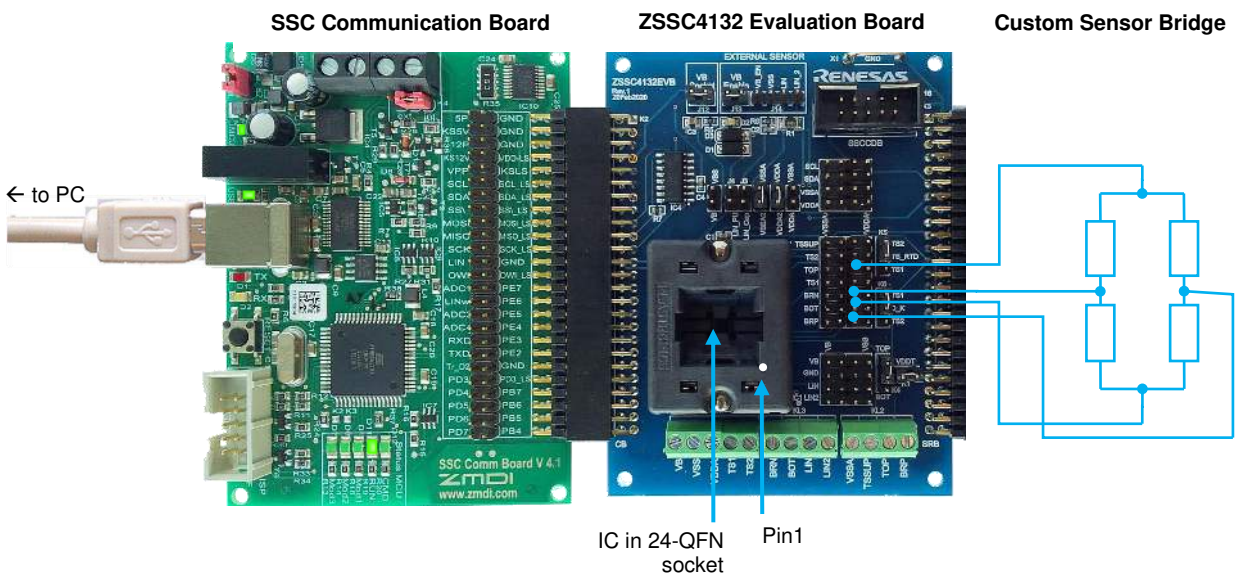

Figure 6. Evaluation Kit Connections Example 2: Connecting External Resistive Sensor Bridge



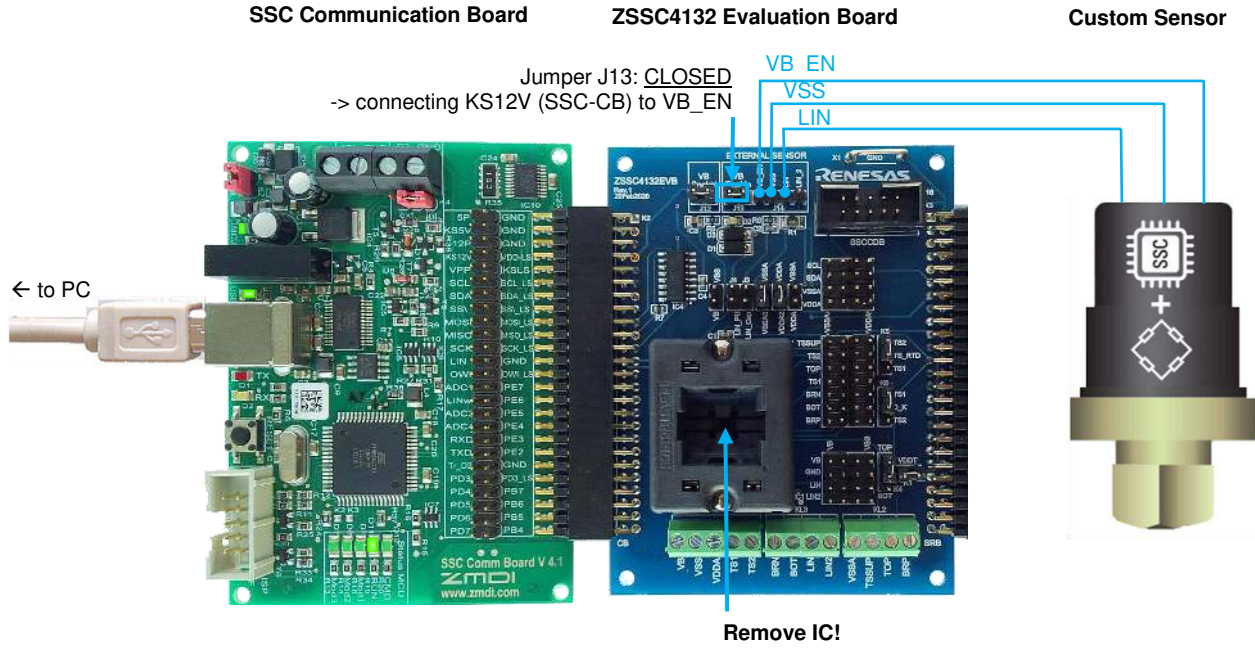

Figure 7. Evaluation Kit Connections Example 3: Connecting External Sensor Including SSC

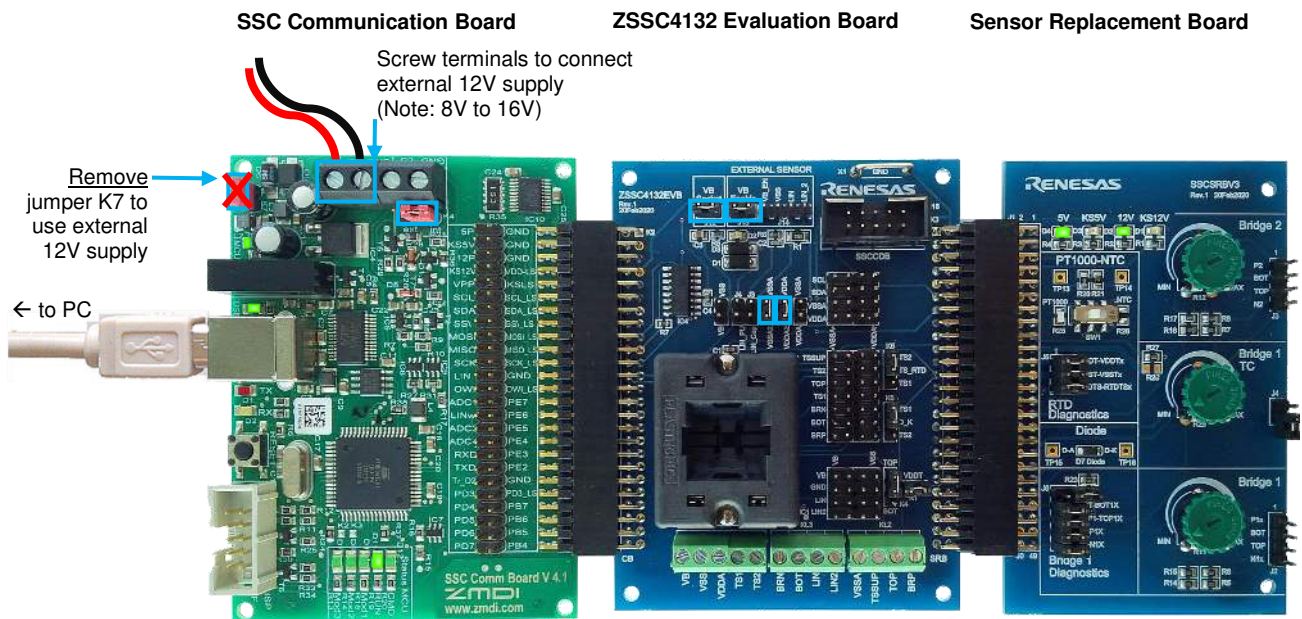

Figure 8. Evaluation Kit Connections Example 4: External 12V Supply via SSC-CB

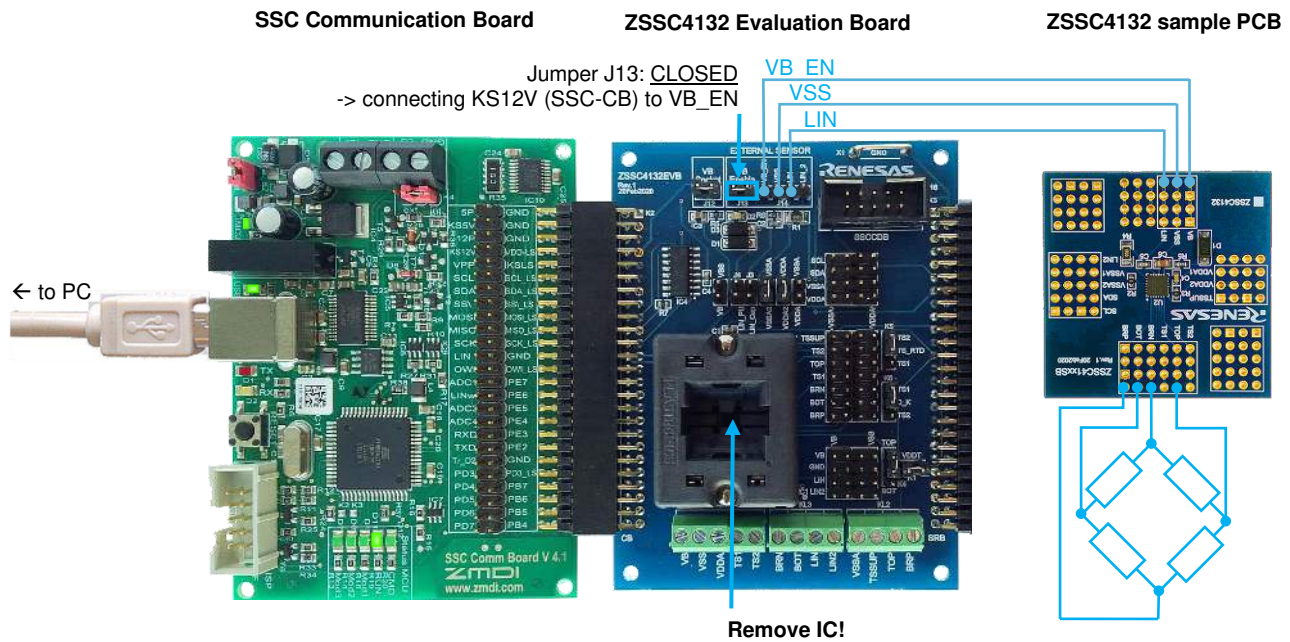

Figure 9. Evaluation Kit Connections Example 5: Connect sample PCB + External Sensor Bridge

## 1.4 External Equipment Connections

Follow these procedures to connect the lab equipment and the user's computer to the kit as shown in Figure 3:

1. Depending on the use case, connect the boards, external sense element and/or sensors as shown in section 1.3. For a first IC evaluation, use default setup as shown in Figure 3.
2. Connect kit with the PC via USB cable.

## 1.5 Power-up and Connection Procedure

In the default setup, the evaluation kit is powered by the USB port of the PC (see Figure 3).

Once the evaluation kit is properly connected and powered, the LEDs D4 (5P) and D2 (12P) on the Sensor Replacement Board lights up, indicating that the permanent 5V and 12V supplies are available. The green LED D4 (MCU) indicates a powered microcontroller on the SSC-CB.

Note: The LED D2 (on SSC-EB) does not light up to indicate that the Evaluation Board and IC has power until the board is activated (connected) as described in section 1.5.

When the Evaluation Kit is connected, start the ZSSC4132 Evaluation Software. The window opens with the "MAIN" application tab displayed (see Figure 10).

"ACTIVE BOARDS" panel on the right side of the window lists the active, correctly connected devices, which will include the SSC Communication Board (see "ZMDI SSC CB V4.1"). Multiple devices can be connected to the user's computer.

Follow these steps to set up communication with the kit:

1. Click on the desired device in the "ACTIVE BOARDS" list. Click "Refresh" after changing any connections.
2. Select a communication protocol (I2C or LIN) in the dropdown menu under "CONNECTION" in the left panel.

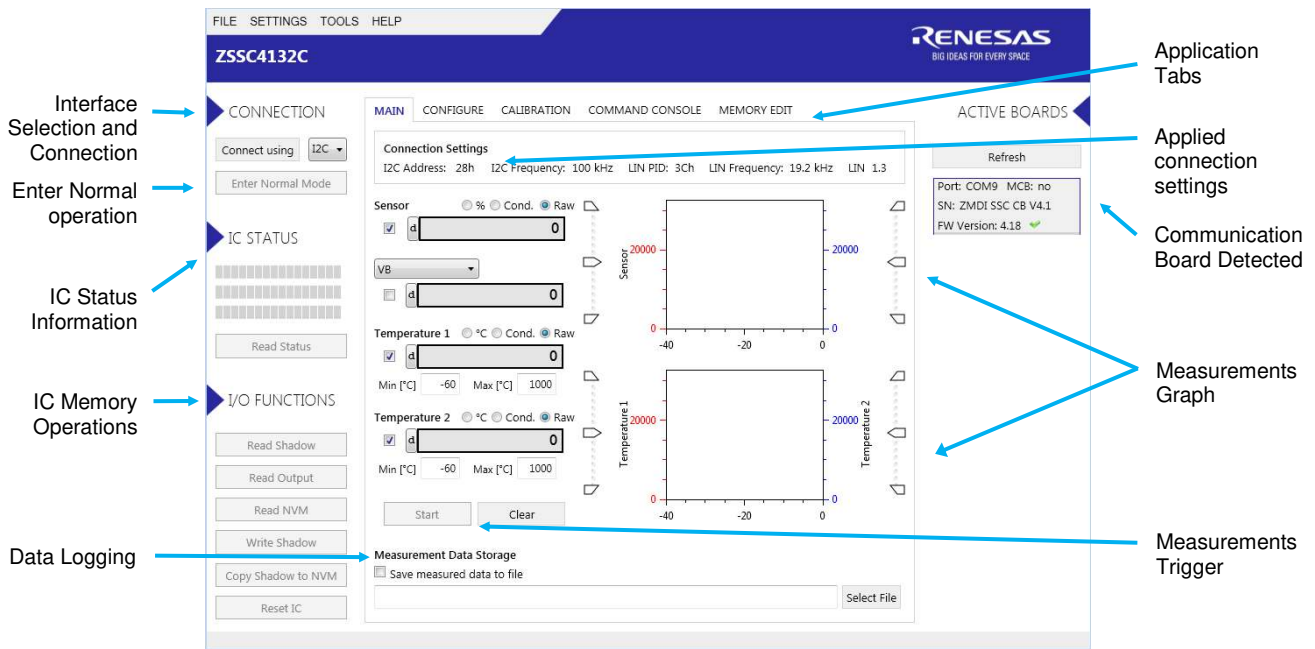

**Figure 10. Initial Display Explained (Evaluation Kit properly connected to USB; IC not activated)**

Note: If necessary, configure the I2C and LIN specific settings via the “SETTINGS” menu on the top banner shown in Figure 11. The new settings are applied when a connection is re-established with ZSSC4132. Settings can be changed only if no IC is connected. The I2C address must be set correctly in order to establish successful I2C communication. The LIN version must be set correctly in order to use LIN communication. LIN version must always be set correctly, because LIN interface is used in Normal mode, even if I2C communication is set.

Note: For proper LIN support, use SSC Communication Board with firmware revision v4.14.17 (and later). The revision is given by the “ACTIVE BOARDS” information box. A suitable firmware is indicated by a green checkmark.

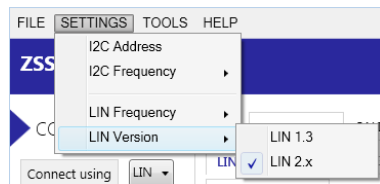

**Figure 11. Settings Menu**

3. Click “Connect using” button to power the IC and establish communication with the device. This enables the switched supplies (KS12V, KS5V). The D2 LED on SSC Evaluation Board turn on to indicate that the Evaluation Board (IC) is powered and connection with IC is properly established.

When communication is correctly established, “Connect using” button changes to “Disconnect”.

The software generates the corresponding data frame structure with initial values gathered from the IC.

IC is entered in Command Mode, memory content (NVM, RAM) and IC status information is read.



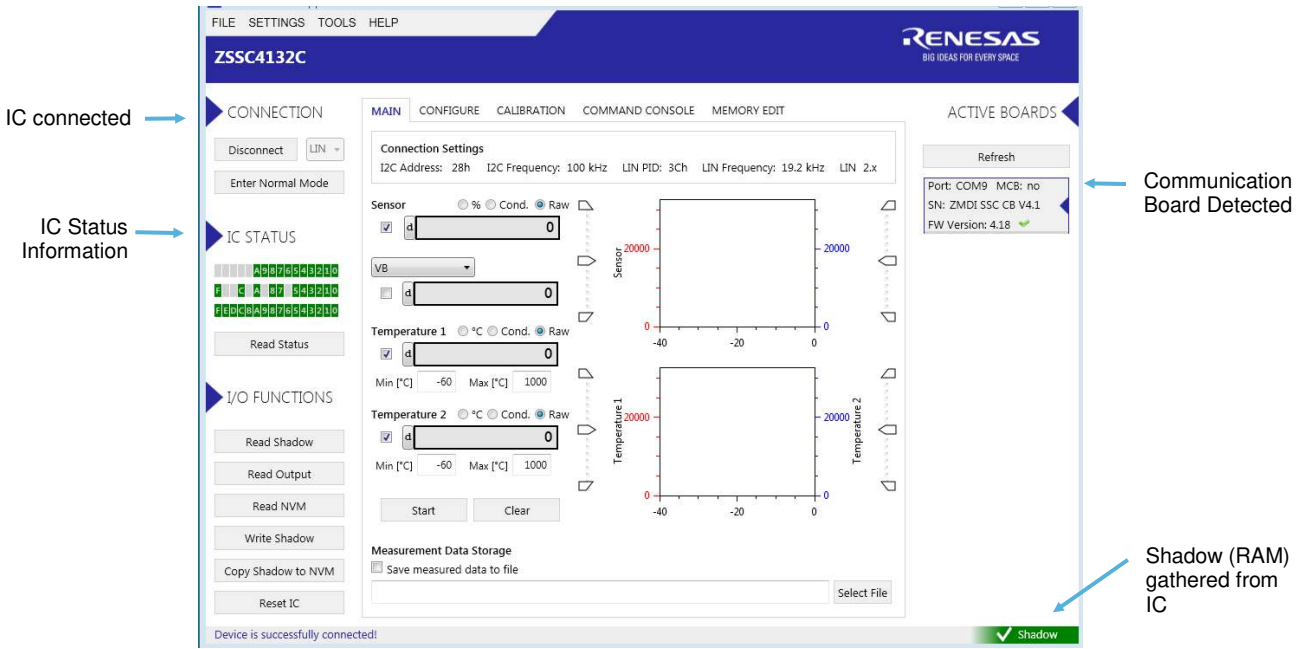

Figure 12. Initial Display after Evaluation Kit and IC Properly Connected

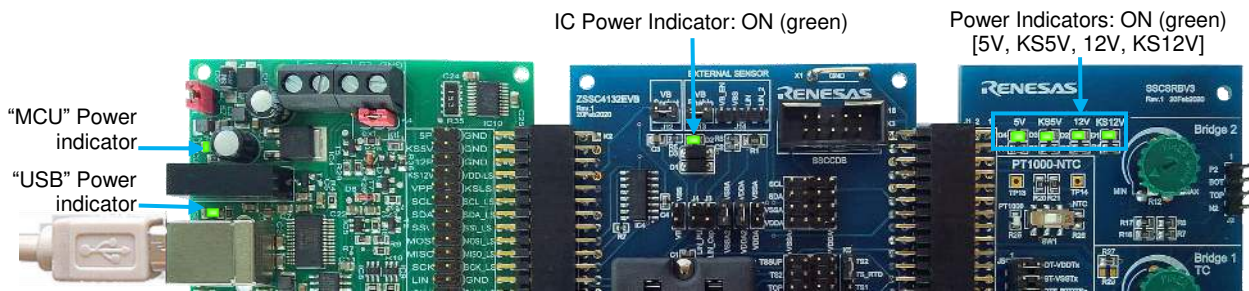

Figure 13. Evaluation Kit – IC connected – Status of Power Indicators



## 2. User Guide

The ZSSC4132 evaluation software is intended for demonstration purposes for configuration and calibration of single units.

### 2.1 General GUI Handling and Settings

#### 2.1.1. Saving and Loading the GUI Configuration File (.cfgx)

Software related settings (for example, connection interface, speed, MAIN tab diagram limits, or calibration settings) can be saved and loaded by file.

A default initial configuration file, `<program_path>\Resources\DefaultConfigurationSettings.cfgx`, is provided with the software.

At first start, a standard configuration file is created at the default user applications folder:

`%USERPROFILE%\AppData\Roaming\Renesas\ZSSC4132 Demonstrator\Resources\StandardConfigurationSettings.cfgx`.

This file is used for quick “Save GUI Configuration”.

For loading a different GUI configuration, follow these steps:

1. Click FILE > “Load GUI Configuration” (see Figure 14)
2. Browse to file location and click the “Open” button.  
The “Load GUI Configuration” window appears.
3. Click the “Yes” button to accept overwriting the current configuration settings.

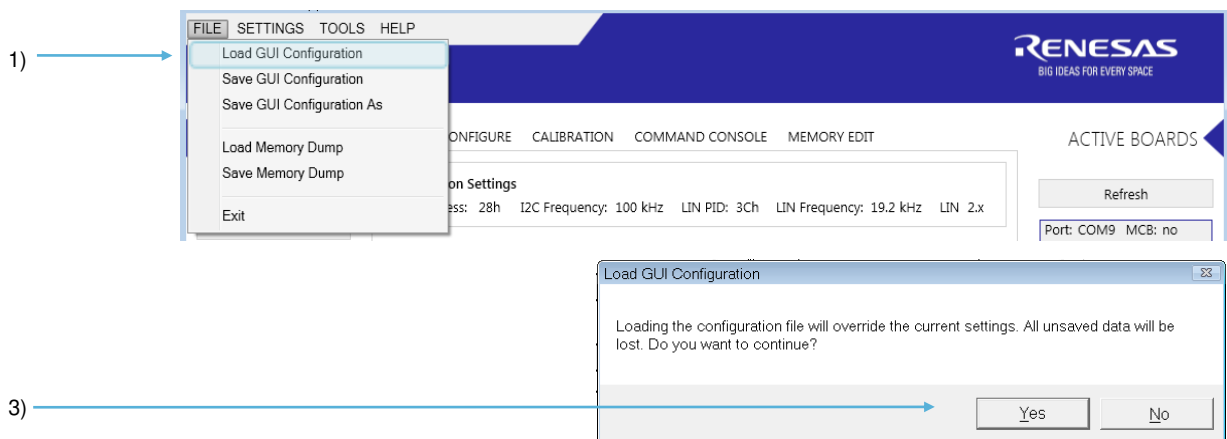

**Figure 14. Loading the GUI Configuration File**

When the Evaluation Software is closed, a “Save Configuration Settings?” window opens.

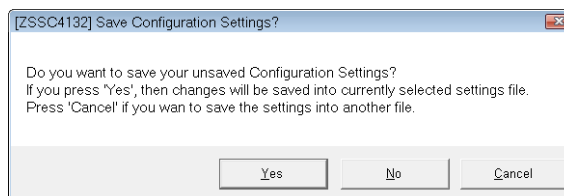

**Figure 15. Save Configuration Dialog Window at Closing**

By clicking “No”, the settings are not saved. By clicking “Yes”, the current configuration of the GUI is saved in the actual \*.cfgx file. By clicking “Cancel”, a different file can be selected to save.

The latest saved file is loaded automatically when the software is started the next time.

## 2.2 Saving and Loading an IC Memory Dump

### 2.2.1. Saving IC Memory Data

Follow these steps to save IC Memory Data to Memory Dump File (.dmpx):

1. Select FILE > Save Memory Dump to save a file containing the IC memory data (see Figure 17).  
A file explorer window will open.
2. Browse to the target file location, enter a file name, and click the “Save” button.

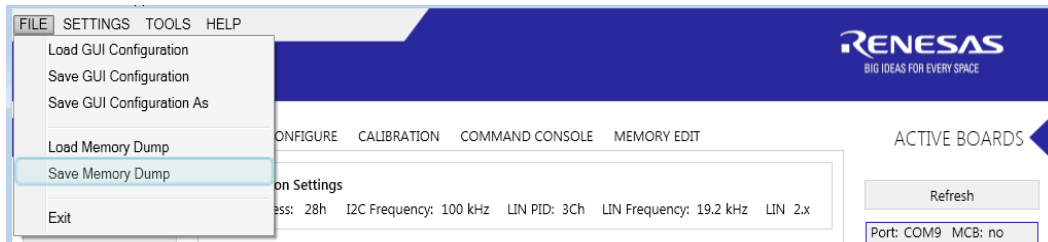

**Figure 16. Save the Memory Data to a File**

Note: The memory dump file contains RAM Shadow, RAM Output Memory and non-volatile memory (NVM) data by default.

### 2.2.2. Loading RAM Shadow Data

Follow these steps to load RAM Shadow data from Memory Dump File (.dmpx):

1. Select *FILE > Load Memory Dump* to load a file containing the IC RAM Shadow memory data (see Figure 17).
2. Browse to the file location, and click the “Open” button.
3. In the “Load MTP Dump” window, click the “Yes” button to accept overwriting current RAM Shadow data in the GUI.

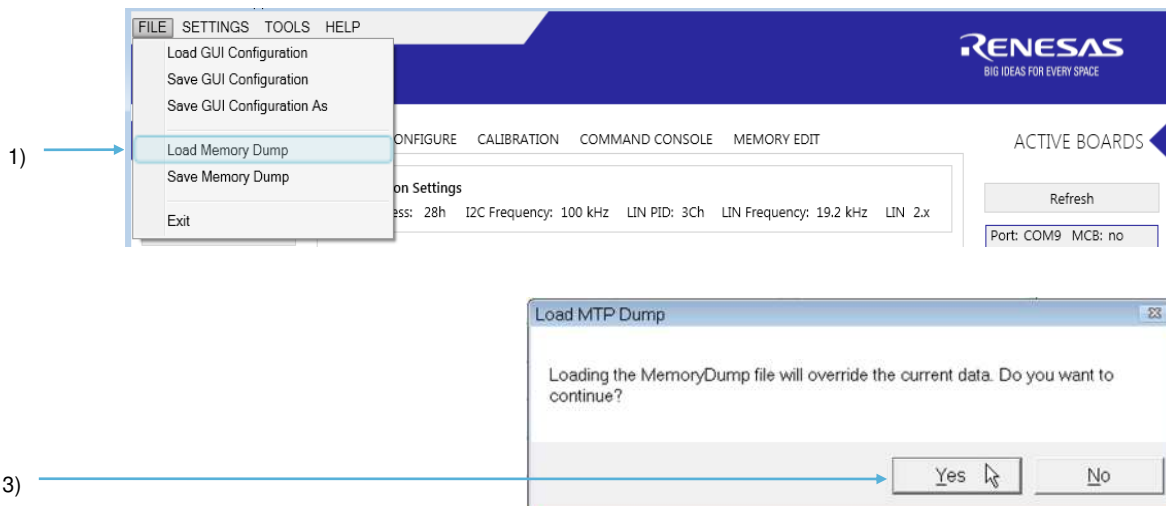

**Figure 17. Load the RAM Shadow Data into GUI**

Note: The GUI loads only RAM Shadow content. Pre-calibrated IC parameters (non-user settings) are not overwritten in the GUI.

Note: Loading certain settings can trigger the GUI to offer certain recommended settings (e.g. PTC settings) by a pop-up window. Please decline this automated settings in order to properly load the saved data!

If the register content is the same as the content from the last reading, the indicator in the bottom right corner of the window stays green as shown on Figure 18.



Figure 18. Memory Indicator: Same Content

If a register is modified, the indicator becomes red as shown on Figure 19.

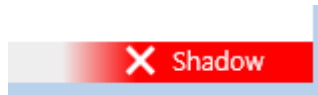

Figure 19. Memory Indicator: Modified Content

### 2.2.3. Writing the Memory Content to the IC

1. Click the “Write Shadow” button to download the RAM Shadow data into the IC (see Figure 20).
2. Click the “Copy Shadow to NVM” button to copy the content of the Shadow memory to NVM and update the CRCs.
3. In the “Copy Shadow to NVM” window, click the “Yes” button to accept permanent overwrite of the NVM memory.

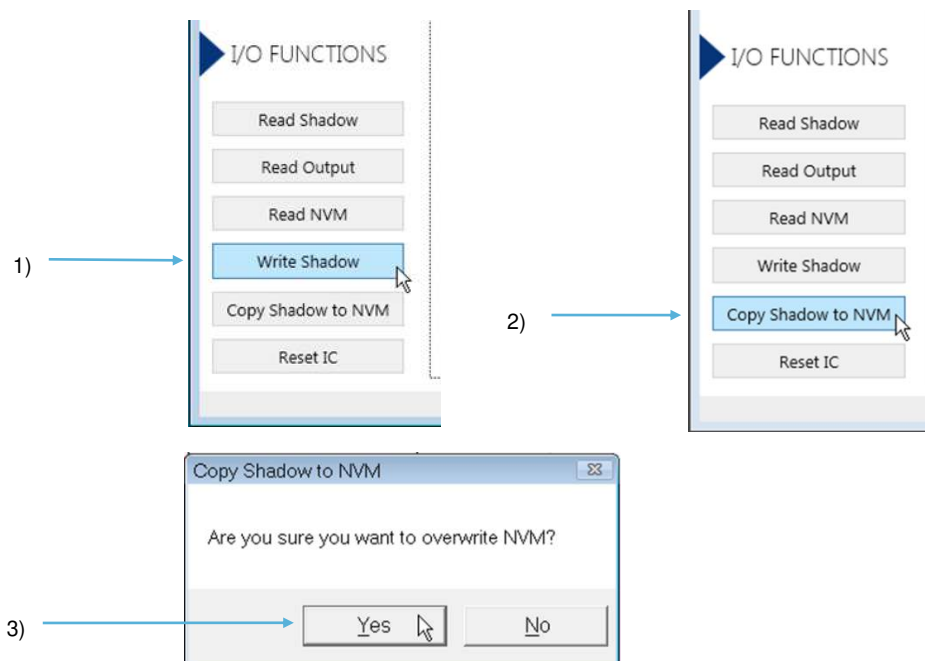

Figure 20. Writing the Configuration into the RAM Shadow and NVM

Note: The “Reset IC” button is performing a power cycle of the IC, and forcing the IC to load configuration from NVM (into Shadow). Any IC settings that are not written to NVM will be lost. In addition, the evaluation software is refreshed.

## 2.3 IC Configuration and Calibration Procedures

### 2.3.1. “CONFIGURE” Application Tab

The “CONFIGURE” application tab offers sub-tabs for settings divided by functional blocks as described in Table 4. These tabs are used for configuring the ZSSC4132 to adapt to the specific application use case and requirements.

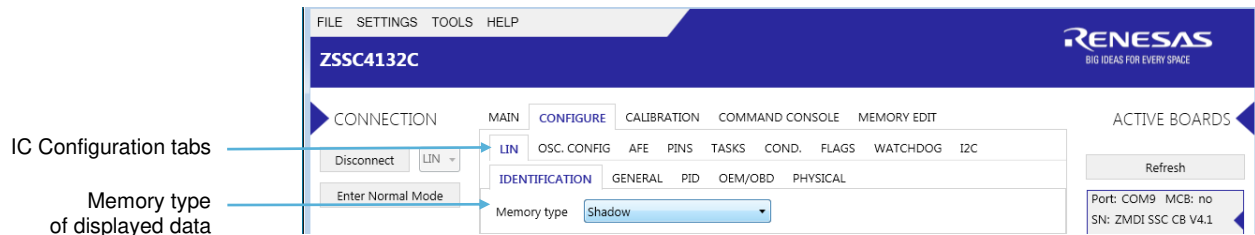

Figure 21. CONFIGURE Tab

Table 4. Sub-tabs of the “CONFIGURE” Tab

Sub-tab	Description
LIN	LIN interface related settings
LIN - IDENTIFICATION	LIN identification (NAD related settings)
LIN - GENERAL	General LIN interface configuration (Revision, SNPD, sleep mode support)
LIN - PID	LIN frame settings (identification, format and arrangement of unconditional frame)
LIN - OEM/OBD	OEM/OBD data settings accessible via LIN interface
LIN - PHYSICAL	Advanced LIN transceiver related settings
OSC. CONFIG	Oscillator settings (setup for oscillator spread spectrum)
AFE	Analog Front End settings (advanced settings)
PINS	Functional settings of the physical sensor pins (for example, operation mode)
TASKS	Measurement cycle task settings (for example, measurement task enabling, task specific ADC and PGA settings (for example, input, resolution, gain, offset), measurement cycle flow settings)
COND.	Sensor Signal Conditioning settings (for example, formula select, coefficients, digital output filtering) Note: Certain settings can be overwritten by the CALIBRATION tab.
FLAGS	Setup of diagnostics (for example, monitors, limits, counters)
WATCHDOG	Watchdog configuration and calculation
I2C	I2C interface configuration

Settings are given by short names (referring to the field names of the memory allocation document). A more descriptive long name is shown by placing the cursor over the input field. Please refer to the *ZSSC4132 Memory Allocation* document for more detailed description of the settings (see product website: [www.IDT.com/ZSSC4132](http://www.IDT.com/ZSSC4132)).

The “Memory type” drop-down menu shows the memory, which is the source of the displayed data.

Note: GUI only allows directly changing settings in Shadow memory. A changed setting is not automatically written to the IC memory. All fields that differ from the last reading of chip memory are marked in red.

Follow these steps to write the changed values to the IC:

1. Click the “Write Shadow” button to change the Shadow memory, which is temporary.
2. Click “Copy Shadow to NVM” button to also change the NVM memory, to make it permanent.

All fields with blue background are read-only by the GUI. Do not change such fields as they can be calibrated parameters.

### 2.3.2. “CALIBRATION” Application Tab

“CALIBRATION” tab combines all tabs to support for calibration that can be applied to ZSSC4132. It offers four sub-tabs:

- BRIDGE-SENSOR
- TEMPERATURE 1
- TEMPERATURE 2
- BRIDGE-SENSOR CHECK

The “CALIBRATION” tab is used for acquiring raw measurement data and calculating the coefficients for the signal linearization and temperature compensation.

#### 2.3.2.1. “BRIDGE-SENSOR” Sub-Tab

“BRIDGE-SENSOR” sub-tab implements the different calibration options for the bridge sensor (BRS) signal conditioning.

The screenshot shows the 'CALIBRATION' application tab with the 'BRIDGE-SENSOR' sub-tab selected. The interface includes several sections: 'Calibration Type Settings', 'Acquisition Settings', 'Calibration points' (a graph), and 'Coefficient result' (a table). Blue callouts with numbers 1 through 7 point to specific elements in the interface, explaining the calibration procedure steps.

**1) Setup settings for Bridge-Sensor signal conditioning and calibration** (points to Calibration Type Settings)

**2) Setup setting for raw data acquisition used for calibration** (points to Acquisition Settings)

**3) Setup setting for temperature reading source for Bridge-Sensor temperature compensation (corresponding measurement task must be enabled – see CONFIGURATION->TASKS)** (points to Temperature Reading Source)

**4) Setup target range and acquire/enter measurement data for calibration** (points to Target% in the Calibration points graph)

**5) Click “Calculate coefficients”** (points to the Calculate coefficients button)

**6) Calibration output log: provide more details for coefficient calculation (can be used for further debugging in terms of failed calibration)** (points to the Calibration output log button)

**7) Calculated coefficients (after calibration)** (points to the Coefficient result table)

**Calibration points graph data:**

Temp [Counts]	T1	T0	T2	T3	Target[%]
Pmax	0	0	0	0	90
P2	0	0	0	0	
P4	0	0	0	0	
P3	0	0	0	0	
P1	0	0	0	0	10
Pmin	0	0	0	0	

**Coefficient result table:**

Nonlinearity Compensation								
W3	W2	W1	W0	C3	C2	C1	C0	
h	0	0	B	0	0000	0000	4000	0000

Temperature Compensation - Gain			
C3	C2	C1	C0
0000	0000	0000	1000

Temperature Compensation - Offset			
C3	C2	C1	C0
0000	0000	0000	0000

Register values in red are different than actual values in chip memory. You need to write them to chip memory in order to take effect.

Figure 22. CALIBRATION/“BRIDGE-SENSOR” Sub-tab – Calibration Procedure

**Table 5. Bridge Sensor - Calibration Type Settings**

Setting	Description
Nonlinearity Compensation (drop down menu)	Select the order of the nonlinearity of the bridge-sensor measurement to be compensated. By increasing the order, also the number of bridge measurement points to be acquired is increased. Adapting this setting influences the calculation of the coefficients.
Temperature Compensation (drop down menu)	Select the order of temperature dependent nonlinearity of the bridge sensor that should be compensated. The order of temperature compensations, also defines the number of temperatures where measurement points need to be acquired. Adapting this setting influences the calculation of the coefficients.
Temperature Gain Fixed Weights <sup>[a] [c]</sup> (checkbox)	Select conditioning formula which is used for temperature dependent gain compensation. This setting will be considered for the coefficient calculation.
Temperature Offset Fixed Weights <sup>[b] [c]</sup> (checkbox)	Select conditioning formula which is used for temperature dependent gain compensation. This setting will be considered for the coefficient calculation.
Bridge-Sensor Characteristic (drop down menu)	Determines which characteristic is going to be calibrated either "BRS1" or "BRS2". This menu is only available if "LinBrs2Ena" is enabled. As "BRS2" coefficients overlap with NTC coefficients in the memory, only one of these two features can be used at once.

[a] Also changes corresponding IC setting ("*BrsCondGainPolynomOrderSel*") to be written to Shadow.

[b] Also changes corresponding IC setting ("*BrsCondOffsPolynomOrderSel*") to be written to Shadow.

[c] As long as temperature dependency up to second order is expected/targeted, it is recommended to uncheck the option to select the second order polynomial with flexible weights. This offers more flexibility and precision for the coefficient calculation, also increasing the chance to find suitable coefficients and a more precise calibration result.

**Table 6. Bridge Sensor Calibration - Acquisition Settings**

Setting	Description
Average (drop down menu)	Determines the number of samples that are going to be acquired and averaged for each raw measurement. Use Averaging (for example, 8 or 16 samples) for calibration is recommended.
Temperature Reading Source <sup>[a]</sup> (drop down menu)	Determines the source of acquired temperature measurement data, also used for the BRS temperature compensation by the IC. Please assure that the corresponding measurement task is enabled, see CONFIGURATION/TASKS in section 2.3.1.

[a] Adapting this setting also changes corresponding IC setting ("*BrsCondTsel*") to be written to Shadow.

After the "Calibration Type Settings" are set, the "Calibration points" section is used for acquiring the raw measurement points used for the calibration. Dependent on the calibration type settings, different text boxes are enabled representing the required points of calibration.

"Target" column contains the fields where the desired percentage of the output (referred to full scale) is filled in for each raw of measurements. Empty fields are assumed with value 0.

"Get" buttons are enabled only if a chip is connected.

The calibration can be also done by filling in all text boxes manually without a chip connected.

Coefficients can be calculated after all enabled text boxes are filled in. "Calibration output log" provides more details of the calculation of the coefficients. For example, it shows intermediate results. The results are shown in "Coefficient result" section.

Successful calculation of the coefficients is indicated by green "SUCCESS" message in the "Coefficient result" paragraph. Failed calculation is indicated by an error message and red "FAILED" indication.

Click "Write Shadow" to write the calculated coefficients to the IC.

You can check the calibration result in the MAIN tab, see section 2.4.1 for details. Click the "Start" button to start a measurement cycle and enable "Cond." or "%" checkboxes for displaying the conditioned values.

Note: Click "Copy Shadow to NVM" to copy settings to NVM (permanently).



### 2.3.2.2. "TEMPERATURE 1" Sub-Tab

"TEMPERATURE 1" sub-tab is used for linearization of temperature 1 reading. It is recommended to use Temperature 1 for the primary/main temperature measurement (usually external medium temperature).

For temperature 1, there are four types of calibration available: Quadratic, Cubic, NTC and PTC.

By selecting the "Calibration Type Setting", the selected Polynomial also changes the corresponding IC setting ("T1CondFormulaSel") and needs to be written to Shadow memory.

For details of the implemented conditioning formulas, please check the *ZSSC4132 Functional Description* document.

#### Quadratic and Cubic Formula Type

1) Choose conditioning formula

2) Setup setting for raw data acquisition

3) Choose number of data points used for calibration -> defines order of calibration target

4) Set target range and acquire/enter measurement data for calibration

5) Click "Calculate coefficients"

6) Calibration output log: provide more details for coefficient calculation (can be used for further debugging in terms of failed calibration)

7) Calculated coefficients (after calibration)

N	Target [%]	Value	Get
1	0	Get	
2	0	Get	
3	0	Get	
4	0	Get	
5	0	Get	
6	0	Get	
7	0	Get	
8	0	Get	
9	0	Get	
10	0	Get	
11	0	Get	
12	0	Get	
13	0	Get	
14	0	Get	
15	0	Get	
16	0	Get	

Polynomial Coefficients							
W3	W2	W1	W0	C2	C1	C0	
h	0	0	8	0	0000	4000	0000

Figure 23. "TEMPERATURE 1" Sub-tab – Calibration type: Quadratic

Choose either of these polynomials to use for conditioning and calibration:

- Quadratic: using second order polynomial temperature conditioning formula (with variable weights).
- Cubic: using third order polynomial temperature conditioning formula (with fixed weights).

The maximum number of data points depends on the calibration type.

Choosing the number of "Data Points", defines the target for calibration:

- 2 points: linear approximation (1st order).
- 3 points: quadratic approximation (2nd order).
- 4 points: cubic approximation (3rd order).

Each data point consists of a target value [%] and a measured value.

Measurement result can be acquired as average result from raw measurement (choose number of averaging by the "Average" drop-down menu in the "Acquisition Settings") or can be filled manually without a connected chip.

The results are shown in "Coefficient result" section after clicking the "Calculate coefficients" button. "Calibration output log" show intermediate results of the calculation.

For linear approximation, it is also possible to use Least-Square Fit method. This increases the number of possible data points to the maximum of 16.

**PTC Formula Type**

PTC measurement requires chip configuration changes related to the recommended setup, see the *ZSSC4132 Functional Description* document for more details of recommended PTC configuration and setup.

When "PTC" is selected from the "Calibration Type Settings" menu, a window pops up with the recommended settings (see Figure 24). By clicking "Yes", the settings are applied on the GUI. By clicking "No", the settings need to be done manually.

Note that these changes only take effect on IC when "Write Shadow" is clicked. Click the "Copy Shadow to NVM" button to apply the changes persistent to the NVM memory..



Figure 24. IC Settings for PT1000 Setup (Configure Pin TS1 and TS2, Measurement Uses Pin TS1)

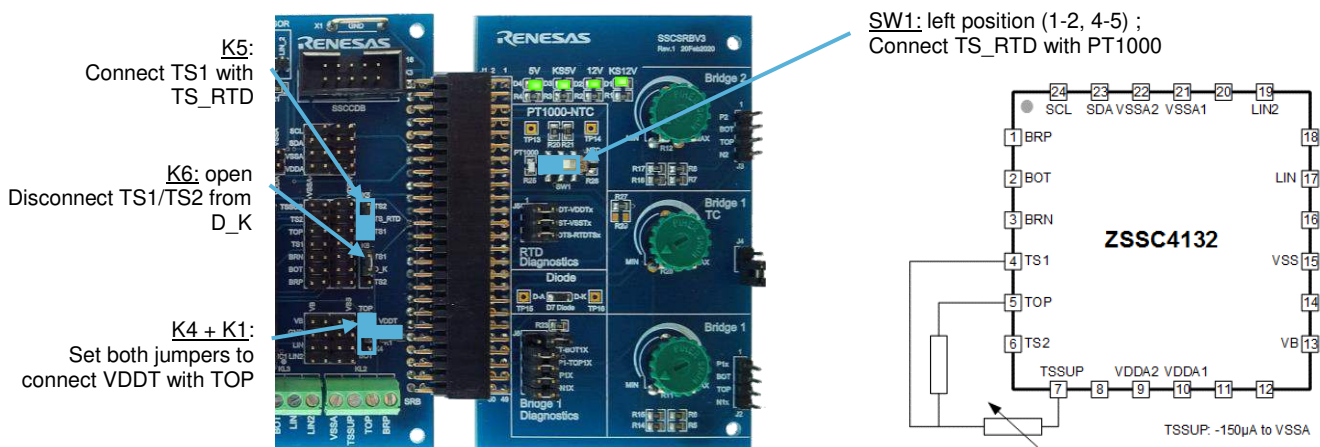

Figure 25. PTC Setup on SSC-EB and SSC-SRB (PT1000 Measured at TS1)

The evaluation software offers support for a PTC 1-point calibration dedicated to PT-type sense elements (for example, PT1000, PT500, etc).

PTC calibration requires six parameters to be assigned:

- a0, a1, a2: to be derived from PTC manufacturer data sheet.
- Rs: typical series resistance of the half-bridge (15 kOhm default on SSC-SRB).
- [Tmin,Tmax] or [Trsl, Toff]: determining the target temperature range (full scale) for calibration.

A single measurement point at the calibration temperature is acquired using “Get” button.

“Calculate coefficients” performs calculation of the coefficients and fills in the calibration result in “Coefficient result” section.

Note: The calibration procedure intends to compensate for variations in the series resistance (Rs) of the single sensor build.

MAIN CONFIGURE **CALIBRATION** COMMAND CONSOLE MEMORY EDIT

BRIDGE-SENSOR **TEMPERATURE 1** TEMPERATURE 2 BRIDGE-SENSOR CHECK

Calibration Type Settings

Polynomial PTC

---

Calibration points			Initial Conditioning Coefficients	
N	Target [°C]	Value		
1	25	Get	a0	1000 Ω
2	6.7	Get	a1	3.906 Ω/K
3		Get	a2	-0.000587 Ω/K <sup>2</sup>
4		Get	Rs	15000 Ω
5		Get	<input checked="" type="radio"/> Min & Max	<input type="radio"/> Trsl & Toff
6		Get	Min	-60 °C
7		Get	Max	300 °C
8		Get	Coefficient result	
9		Get	Polynomial Coefficients	
10		Get	C PTC	C2
11		Get	C1	C0
12		Get	h	00B0
13		Get		0000
14		Get		4000
15		Get		0000
16		Get		

Calculate coefficients

Calibration output log

Register values in red are different than actual values in chip memory. You need to write them to chip memory in order to take effect.

Figure 26. "TEMPERATURE 1" Sub-Tab – Calibration Type: PTC

### NTC Formula Type

NTC measurement requires mandatory changes in chip configuration related to the recommended setup, see the *ZSSC4132 Functional Description* document for more details of NTC configuration and setup.

When "NTC" is selected from the "Calibration Type Settings" menu, a window pops up with the recommended settings (see Figure 27). By clicking "Yes", the settings are applied on the GUI. By clicking "No", the settings need to be done manually.

Note that the changes only take effect temporary on the IC when "Write Shadow" is clicked. Click the "Copy Shadow to NVM" button to apply the changes persistently to the NVM memory.

Note: NTC coefficients share the same registers in memory as the coefficients for a second bridge characteristic (BRS2). Only one of the two features can be used at the same configuration.

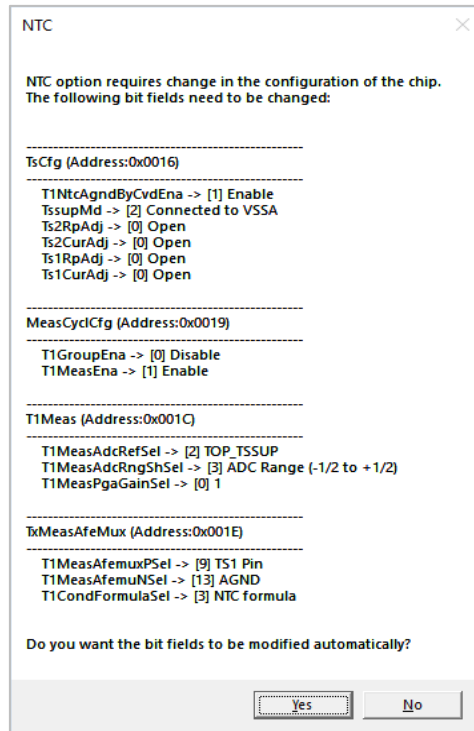

Figure 27. IC Settings for NTC (Configure Pin TS1 and TS2, Measurement Uses Pin TS1)

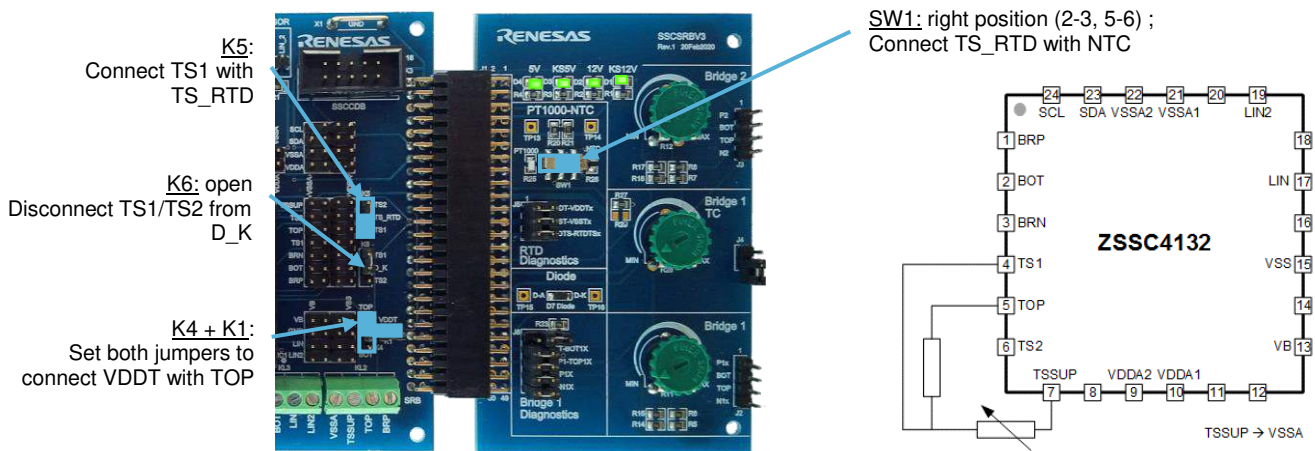

Figure 28. NTC Setup on SSC-EB and SSC-SRB (NTC Measured at TS1)

The GUI does not support import of NTC characteristic and direct calculation/calibration of the spline coefficients for NTC configuration.



### 2.3.2.3. "TEMPERATURE 2" Sub-Tab

"TEMPERATURE 2" sub-tab is used for linearization of temperature 2 reading. It is recommended to use Temperature 2 for the second/auxiliary temperature measurement.

For temperature 2, there are two types of calibration available: None and Quadratic.

- None: means that temperature 2 reading would not be linearized.
- Quadratic: using second order polynomial temperature conditioning formula (with fixed weights).

By selecting the "Calibration Type Setting", the selected Polynomial also changes the corresponding IC setting ("T2CondFormulaSel") and needs to be written to Shadow.

Choosing the number of "Data Points", defines the target for calibration:

- 2 points: linear approximation (1st order).
- 3 points: quadratic approximation (2nd order).

Each data point consists of a target value [%] and a measured value.

Measurement result can be acquired as average result from raw measurement (choose number of averaging by the "Average" drop-down menu in the "Acquisition Settings") or can be filled manually without a connected chip.

The results are shown in "Coefficient result" section after clicking the "Calculate coefficients" button. "Calibration output log" show intermediate results of the calculation.

For linear approximation, it is also possible to use Least-Square Fit method. This increases the number of possible data points to the maximum of 16.

1) Choose conditioning formula

2) Setup setting for raw data acquisition

3) Choose number of data points used for calibration -> defines order of calibration target

4) Set target range and acquire/enter measurement data for calibration

5) Click "Calculate coefficients"

6) Calibration output log: provide more details for coefficient calculation (can be used for further debugging in terms of failed calibration)

7) Calculated coefficients (after calibration)

N	Target [%]	Value	Get
1		0	Get
2		0	Get
3		0	Get
4		0	Get
5		0	Get
6		0	Get
7		0	Get
8		0	Get
9		0	Get
10		0	Get
11		0	Get
12		0	Get
13		0	Get
14		0	Get
15		0	Get
16		0	Get

Polynomial Coefficients		
C2	C1	C0
h	0000	2000
	0000	0000

Register values in red are different than actual values in chip memory. You need to write them to chip memory in order to take effect.

Figure 30. "TEMPERATURE 2" Sub-Tab – Calibration Type: Quadratic

### 2.3.2.4. "BRIDGE-SENSOR CHECK" Sub-Tab

If bridge sensor diagnostics is required, the tab Bridge-Sensor Check calibration supports three types of procedures covering different levels of diagnostic.



For a more detailed description of bridge sensor diagnostic features, please refer to the product documentation (such as *ZSSC4132 Functional Description*).

**Table 7. Bridge Sensor Check – Diagnostic Levels and Calibration Procedures**

Setting/Diagnostic Level	Description
Wire Break Detection	No calibration required; only comparator mode used.
Wire Break and Short Detection	To be calibrated by acquiring two data points at single temperature (for example, 25 °C). Using comparator and analog limit mode without temperature compensation. Recommended for bridge sensors with low temperature coefficient ( $-1000\text{ppm/K} < t_c < 1000\text{ppm/K}$ ).
Wire Break and Short Detection with Temperature Dependent BRS	To be calibrated by acquiring six data points at two different temperatures. Using limit mode with temperature compensation and comparator mode of BRSC in parallel. Note that it requires an enabled RPTAT measurement. Recommended for bridge sensors with “high” temperature coefficient ( $ t_c  > 750\text{ppm/K}$ ).

By selecting one of the procedures, a dialog window is displayed to automatically set the appropriate IC settings. Clicking “Yes” applies the necessary changes.

Note that these changes only take effect on IC when “Write Shadow” button is clicked. Click the “Copy Shadow to NVM” button to apply the changes persistently to the NVM.

1) Choose level of bridge sensor diagnostic; apply proposed settings by pop-up window

2) Apply calibration temperature T0 and acquire measurement data

3) Apply calibration temperature T1 and acquire measurement data

4) Enter typical sensor bridge resistance

5) Click “Calculate coefficients”

6) Check calculated coefficients and limits (after calibration)

Register values in red are different than actual values in chip memory. You need to write them to chip memory in order to take effect.

**Figure 31. "BRIDGE SENSOR CHECK" Sub-Tab – Wire Break and Short Detection with Temperature Compensation**

The reading of data points are triggered using the “Get” buttons, which are only active when a DUT is connected. The parameters can also be filled in manually for a dry run, when there is no chip connected. “Calculate coefficients” button gives the result in the “Coefficient result” section.

## 2.4 Evaluation Procedures

The effect and results can be evaluated if the required application settings and calibrations are done.

It is possible to check the effect of Shadow memory settings on the “IC STATUS” section of GUI and on the “MAIN” tab. These settings can be written to NVM.

Use the “Normal Mode” to check for correct operation in application based on NVM settings.

### 2.4.1. “MAIN” Application Tab

Primary functions of the “MAIN” tab on Figure 32:

- “Start” button: start measurement cycle and begin acquiring and recording measurement data. The measurement cycle is using the settings from RAM/Shadow. Once it’s clicked, “Start” button changes to “Stop”.
- “Stop” button: stop measurement and reading.
- Check boxes on the left side: determine which values are going to be displayed. Readings are taken from RAM output memory using the connected interface. Readings are displayed as numerical values and graphs.

Note: The IC stays in Command Mode using current settings in Shadow memory. Operation settings that are only valid in Normal Mode (like Watchdog settings) are not active.

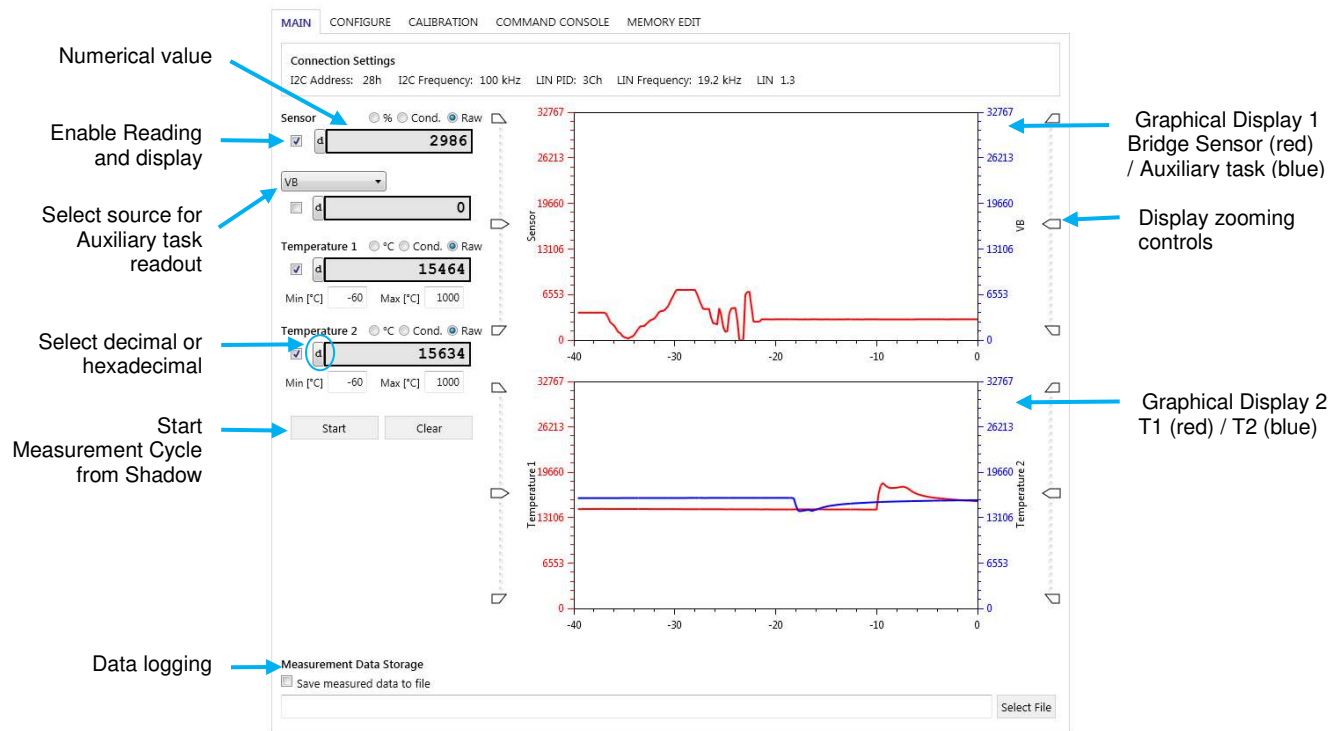

Figure 32. Measurement Readings on "MAIN" Tab

Table 8. MAIN Tab – Measurement Readings

Signal	Description
Sensor	Bridge Sensor measurement; reading as: <ul style="list-style-type: none"> <li>• “Raw”: raw measurement result (auto-zero corrected).</li> <li>• “Cond.”: conditioned and filtered result (without LIN output scaling).</li> <li>• “%”: conditioned result as percentage of full scale range.</li> </ul>
Auxiliary	Select one of the following parameters: VB, VDDA, VDDD, LPTAT, RPTAT, Gain1, Gain2, Gain_diff, TSC, TSC_diff_abs, BrSC1, BrSC2, BrSC_add, and BrSC_diff.

Signal	Description
Temperature 1/Temperature 2	T1/T2 measurement; reading as: <ul style="list-style-type: none"> <li>• “Raw”: raw measurement result (auto-zero corrected).</li> <li>• “Cond.”: conditioned and filtered result (before LIN output scaling).</li> <li>• “°C”: conditioned result in degree Celsius rated by “Min [°C]” and “Max [°C]” limits.</li> </ul>

Note: Measurement tasks need to be enabled to get valid readings (see section 2.3.1 and TASKS settings for details).

For the raw and conditioned numerical values, the format (hexadecimal or decimal) is selected by clicking the small button on the left of the value display box (see Figure 32).

The values are also displayed in a graph:

- The top graph shows “Sensor” and “Auxiliary” measurements.
  - Sensor measurement is displayed in red color with its vertical axis is on the left of the graph.
  - Auxiliary measurement is displayed in blue color with vertical axis is on the right.
- The bottom graph shows “Temperature 1” and “Temperature 2” measurements.
  - Temperature 1 measurement is displayed in red color with its vertical axis is on the left.
  - Temperature 2 measurement is displayed in blue color with its vertical axis is on the right.

Enable the “Measurement Data Storage” check box to allow: data logging of the reading.

#### 2.4.2. “IC STATUS” Section

In the left panel under “IC STATUS”, the status of the device is indicated by the color of the virtual LEDs (see Figure 33):

- Green: The corresponding status bit is ok.
- Red: A flag has been raised.
- Gray: Inactive.

The three lines of status indicator represent as follows:

1. “RdIcStatus” command (0x60) response. Read once after the end of a continuous measurement.
2. “FailStatToLin” memory register in Output Memory (address 0x25). Read after each reading in a continuous measurement.
3. “FailureStatus” memory register in Output Memory (address 0x26). Read after each reading in a continuous measurement.

Click the “Read status” button to read the current IC-status flags.

The IC status Panel is also updated regularly while MAIN tab measurement is running.

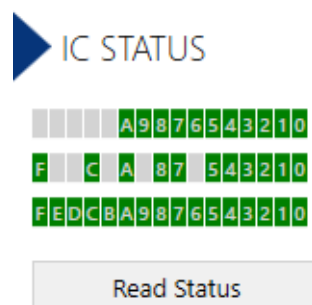

Figure 33. IC STATUS Panel

### 2.4.3. “Normal Mode” Window

Click “Enter Normal Mode” button to open “Normal Mode” window. Opening this window puts the IC in normal operation and reads the LIN output (regardless of the selected interface for connection).

It reads the two LIN publisher frame configurations (based on NVM settings) and draws three graphs based on the reading: “Bridge Sensor”, “Temperature 1” and “Temperature 2”, if available in the frame. Readings of PID0 frame are shown in green and readings of PID1 frame are shown in yellow.

On the bottom of the window, all included signals of the two frames are displayed as numerical readings (decimal and hexadecimal).

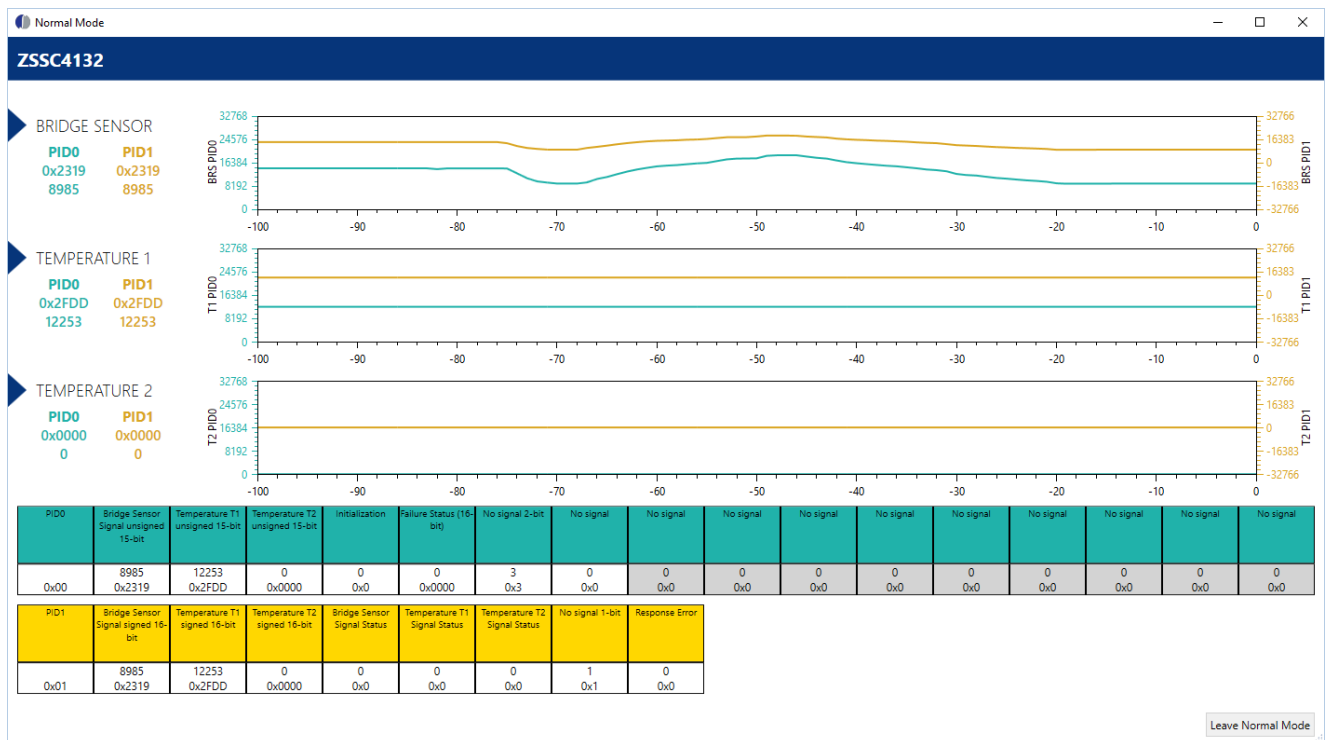

Figure 34. LIN Publisher Frame Output in "Normal Mode" Window

Note: Starting the Normal Mode means that the IC copies the settings from NVM to Shadow and start normal operation. Temporary settings in Shadow are lost, if not copied to NVM before. The IC leaves Command Mode.

Click “Leave Normal Mode” to stop normal operation and close the Normal Mode window. The IC enters Command Mode. The GUI settings are updated by reading Shadow and Output memory from IC.

## 2.5 “Command Console” Tab

On the “COMMAND CONSOLE” tab, the user can write commands directly to evaluation kit (and IC) and see the response in the output window.

A previously edited script file can be loaded and executed directly as a command sequence by clicking the “Browse” button, selecting a file, and clicking the “Execute Script” button shown in Figure 35. The script file must be a text file (\*.txt) with valid commands. Comments can be present in the script file using the special symbol “#” at the beginning of the line.

Predefined commands can be generated by using the drop-down menu “Command” and adding the additional data in “Data” text box. It’s up on user to check for correctness. In order to read an IC response, a read command needs to be triggered.

Previously sent commands can be called again by pressing Error Up Arrow key when single command text box is in focus.

The output data can be copied and saved for further analysis by right-clicking on the results in the display.

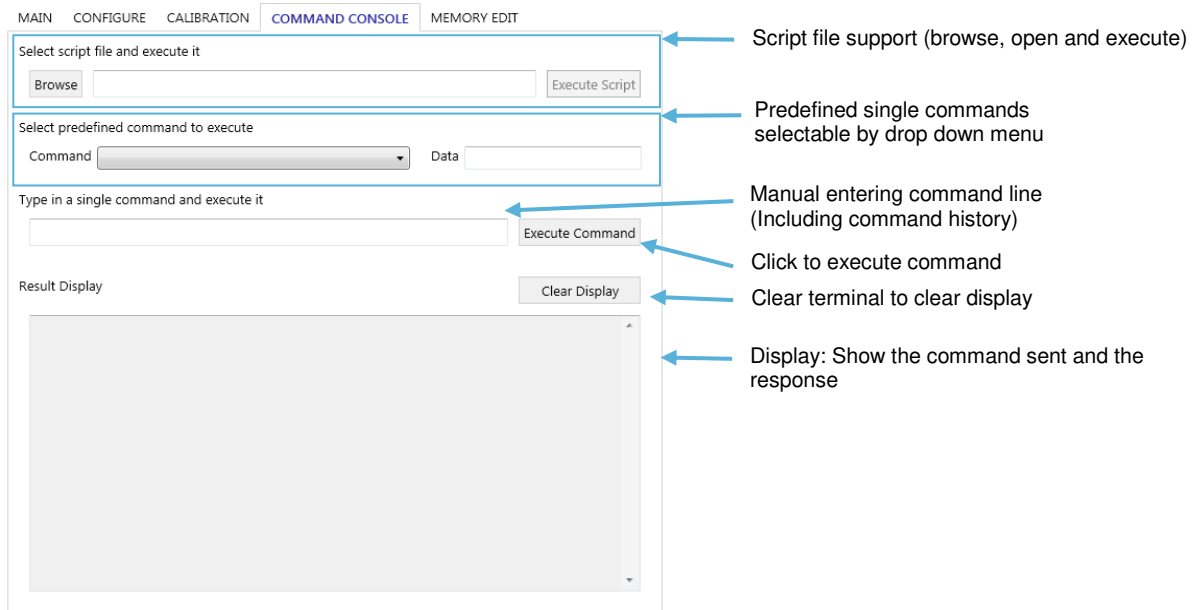

Figure 35. “COMMAND CONSOLE” Tab

The syntax of the SSC communication board is used for handling the different communication interfaces (LIN, I2C) to the IC.

For details check SSC communication board syntax (SSC\_CB\_Command\_Syntax\_Version\_4\_xx.xlsx) included in the firmware update package. It can be downloaded on the SSC-CB webpage: [www.IDT.com/SSC-CB](http://www.IDT.com/SSC-CB)

The IC specific commands are described in the command description document.

The LIN specific services supported by the IC are described in the *ZSSC4132 LIN Data Link Layer Manual* document on the [www.IDT.com/ZSSC4132](http://www.IDT.com/ZSSC4132)

Table 9. Command Console – General Setup Commands

Command	Description	Expected Response (example)
V	Read firmware version string of the SSC-CB	<ACK>V4.18 ? ZMD AG 2019 - CB    SVN: 10144
V_HW	Read hardware information of connected CB and EVB)	<ACK>SSC CB V4.1 : SSC EB N032 - ZSSC4132
T11050	Setup Trigger: switch on both supplies (KS12V, KS5V) with 50ms delay between power-on and first command.	<ACK>
T00000	Power off	<ACK>
IS_07 (IS_11, IS_10)	Setup I2C speed to 400kHz (100kHz, 50kHz)	<ACK>
LOV1	Set LIN interface version to v1.3	<ACK>
LOV2	Set LIN interface version to v2.x	<ACK>
LO_2000001	Set LIN interface settings (19.2kHz, 13 bit Break Field, no Break Delimiter, no Inter-Byte Space Header, no Response Space, no Inter-Byte Space Response, no Inter-Frame Space Response, calculate CRC automatically) = default	<ACK>
TWAITxxxxx	Delays a specific amount of milliseconds (xxxxx - milliseconds to wait). – e.g. TWAIT10 = 10ms delay	<ACK>
PS_A51	Turn on KS5V (switchable 5V	<ACK>
PS_A61	Turn on KS12V (switchable 12V)	<ACK>
PS_A50	Turn off KS5V (switchable 5V	<ACK>
PS_A60	Turn off KS12V (switchable 12V)	<ACK>
... \ ...	List of commands (“\” = separator)	<ACK> ...\......



### 2.5.1. I2C Commands (Example)

Table 10 lists some examples using I2C interface commands.

**Table 10. Command Console – I2C Commands (Example)**

Command	Description	Expected Response (example)
IW_aabbbdd..	Write I2C command, with: <ul style="list-style-type: none"> <li>• aa: I2C address</li> <li>• bbb: number of bytes to write</li> <li>• dd: bytes to be written (= command code + arguments)</li> </ul>	<ACK>
IR_aabbb	Read I2C response, with: <ul style="list-style-type: none"> <li>• aa: I2C address</li> <li>• bbb: number of bytes to read</li> </ul>	Returned bytes
IWTAabbbdd...	PowerOn using predefined Trigger & Write I2C command	<ACK>
<b>Examples</b>		
IWT28003727EA9 IR_28001	Power On & send "Start Command Mode" Read command response (1 byte)	<ACK> <ACK>72
IW_280017C IR_28003	Send "Read Product Version Code"(0x7C) Read command response (3 byte)	<ACK> <ACK>7C 0624 <ul style="list-style-type: none"> <li>• 0x7C = command response (success);</li> <li>• 0x0624 = Product Version Code</li> </ul>
IW_2800160 IR_28003	Send "Read IC Status Register" (0x60) Read command response (3 byte )	<ACK> <ACK>60 0000 <ul style="list-style-type: none"> <li>• 0x60 = command response (success);</li> <li>• 0x0000 = no flags</li> </ul>
IW_2800326007F IR_28257	Send "Read NVM in Burst Mode"(0x26) with Shadow start address: 0x00, word count: 0x7F (-> 128 words) Read command response -> read 257 bytes (= 2x128 + 1)	<ACK> <ACK>22 0080 0019 ... B01E <ul style="list-style-type: none"> <li>• 0x26 = command response (success)</li> <li>• 0x0080 = data of shadow addr. 0x00</li> <li>• 0x0019 = data of Shadow addr. 0x01</li> <li>• ..</li> <li>• 0xB01E = data of Shadow addr. 0x7F</li> </ul>
IW_2800322007B IR_28249	Send "Read Shadow Memory in Burst Mode"(0x22) with Shadow start address: 0x00, word count: 0x7B (-> 124 words) Read command response -> read 249 bytes (= 2x124 + 1)	<ACK> <ACK>22 0080 0019 ... 0311 <ul style="list-style-type: none"> <li>• 0x22 = command response (success)</li> <li>• 0x0080 = data of shadow addr. 0x00</li> <li>• 0x0019 = data of Shadow addr. 0x01</li> <li>• ..</li> <li>• 0x0311 = data of Shadow addr. 0x7B</li> </ul>
IW_2800103	Send "Start Measurement and Conditioning Cycle from Shadow Memory" (0x03)	<ACK>
IW_280012C IR_28079	Send "Read Output Memory"(0x2C) with start address 0x00 and word count 38 (=39 words) Read command response -> read 79 bytes (= 2x39 + 1)	<ACK> <ACK>2C XXXX YYYY ... <ul style="list-style-type: none"> <li>• 0x2C = command response (success)</li> <li>• 0xXXXX = data of OutMem addr. 0x00</li> <li>• 0xYYYY = data of OutMem addr. 0x01</li> <li>• ..</li> </ul>
IW_2800107	Send "Stop Run"(0x07) of measurement cycle	<ACK>

Command	Description	Expected Response (example)
IW_28003096400  (TWAITxxxxx) IR_28001	Send "Start Measurement" (0x09) with Averaging = 8 samples, auto-zero compensation = enabled, using normal operation measurement cycle from Shadow (consider wait time for execution) Read command response (1 byte)  -> when finished, the averaged measurement results can be read from Output memory section in RAM	<ACK>  <ACK>09 <ul style="list-style-type: none"> <li>• 0x09 = command successful finished</li> <li>• (0x00 = command in execution)</li> </ul>
IW_28251 23 007B0080 0019.. ..0311	Send "Write Shadow Memory in Burst Mode"(0x23) <sup>[a]</sup> with Shadow start address = 0x00, word count = 0x7B (124 words), 124 data words (= 248 bytes): 0x0080 @ addr.0x00; 0x0019 @ addr.0x01; ...; 0x0311 @ addr.0x007B	<ACK>
IW_28003153C5B	Send "Write NVM Write Authorization" (0x15) with NVM Write Authorization Key 0x3C5B	<ACK>
IW_2800114 IR_28003	Send "Read NVM Write Authorization Status" (0x14) Read command response	<ACK> <ACK>14 0001 <ul style="list-style-type: none"> <li>• 0x14 = command response (success)</li> <li>• 0x0001 = NVM Write Enabled</li> </ul>
IW_280031A0007  wait ≈ 744ms  IR_28003	Send "Copy Shadow Memory to NVM" (0x20) with all pages (ShdwPgLInObd, ShdwPgApplCfg, ShdwPgLInId) selected and CRCs calculated Wait ≈ 744 ms (124 register * 6 ms max. programming time per word); Read command response	<ACK>  <ACK>1A 0000 <ul style="list-style-type: none"> <li>• 0x1A = command response (success)</li> <li>• NVM successfully written</li> </ul>
IW_2800101	Send "Start Normal Mode"	<ACK>

[a] Do not change calibrated parameters! For details, please check Memory Allocation document.

## 2.5.2. LIN Commands (Example)

Table 11 lists some examples using LIN interface commands.

For detailed description of LIN services and handling supported by the IC, see *ZSSC4132 LIN Data Link Layer Manual* document on product webpage.

**Table 11. Command Console – LIN Commands (Example)**

Command	Description	Expected Response (Example)
<b>General</b>		
LW_aabbbdd..	Write LIN command, with: <ul style="list-style-type: none"> <li>• aa: LIN frame identifier (ID)</li> <li>• bbb: number of bytes to write</li> <li>• dd: bytes to be written = 2 × byte count</li> </ul>	<ACK>
LR_aabbb	Read LIN slave response, with: <ul style="list-style-type: none"> <li>• aa: LIN address</li> <li>• bbb: number of bytes to read</li> </ul>	<ACK>Returned bytes
LWtaabbbdd...	Power On using predefined Trigger & Write LIN command	<ACK>
LW_aabbbd\LR_aabbb	List of a LIN write and LIN read (separator = "\"); Used in order to request the LIN slave response before discarded by timeout (≈1s)	<ACK>\Returned bytes

Command	Description	Expected Response (Example)
<b>General Example</b>		
LW_3C0087F04B4xyyyyFFFF	Send a single LIN frame command Via Diagnostic frame (transport layer) using the LIN Data-Dump service (SID 0xB4) – with: <ul style="list-style-type: none"> <li>• 0x3C = Frame ID reserved for Master Request frame</li> <li>• 008 = 8 data bytes to send</li> <li>• 0x7F = NAD (Broadcast)</li> <li>• 0x04 = PCI (single frame, 4 bytes)</li> <li>• 0xB4 = SID for the Data-Dump service</li> <li>• xx = Command code (1byte, hex)</li> <li>• yyyy = Optional argument (2 byte, hex)</li> <li>• 0xFFFF = Unused bytes filled with 0xFF</li> </ul>	<ACK>
LR_3D008	Read command response – with: <ul style="list-style-type: none"> <li>• 0x3D = Frame ID reserved for Slave Response frame</li> </ul>	<ACK>19 04 F4 xx yyyy FFFF <ul style="list-style-type: none"> <li>• 0x19 = configured NAD of IC</li> <li>• 0x04 = PCI (single frame, 4bytes)</li> <li>• 0xF4 = RSID for Data-Dump service</li> <li>• xx = command response (hex)</li> <li>• yyyy = Return data (optional, hex)</li> <li>• 0xFFFF = unused bytes filled with 0xFF</li> </ul>
<b>Examples</b>		
LWT3C0087F04B4727EA9FFFF \ LR_3D008	Power On & send “Start Command Mode” via LIN Data-Dump service (SID 0xB4) Read command response (8 data byte)	<ACK> \ 19 04 F4 727272 FFFF <ul style="list-style-type: none"> <li>• 0x19 = NAD; 0x04=PCI; 0xF4=RSID; 0x727272=“StrtCmdMd” success</li> </ul>
LW_3C0087F02B47CFFFFFFFFF \ LR_3D008	Send “Read Product Version Code”(0x7C) via LIN Data-Dump service (SID 0xB4) Read command response (8 data byte)	<ACK> \ 19 04 F4 7C 0624 FFFF <ul style="list-style-type: none"> <li>• 0x19 = NAD; 0x04=PCI; 0xF4=RSID;</li> <li>• 0x7C = command response;</li> <li>• 0x0624 = Product Version Code</li> </ul>
LW_3C0087F02B460FFFFFFFFF \ LR_3D008	Send “Read IC Status Register” (0x60)  Read command response (8 data byte)	<ACK> \ 1904F4600000FFFF <ul style="list-style-type: none"> <li>• 0x19 = NAD; 0x04=PCI; 0xF4=RSID;</li> <li>• 0x60 = command response;</li> <li>• 0x0000 = no flags</li> </ul>
LW_3C0087F04B4240000FFFF \ LR_3D008  ..to be repeated for each NVM address/word	Send “Read NVM Word ”(0x24) via LIN Data-Dump service (SID 0xB4) from NVM address = 0x0000 Read command response (8 data byte)	<ACK> \ 19 04 F4 24 00 80 FFFF <ul style="list-style-type: none"> <li>• 0x19 = NAD; 0x04=PCI; 0xF4=RSID;</li> <li>• 0x24 = command response;</li> <li>• 0x00 = High byte of NVM addr. 0x00</li> <li>• 0x80 = Low byte of NVM addr. 0x00</li> <li>• 0xFFFF = unused bytes filled with 0xFF</li> </ul>

Command	Description	Expected Response (Example)
LW_3C0087F0523212700F8FF	Read Shadow Memory content from RAM via LIN "Read-Memory-By-Address" service (SID 0x23) <ul style="list-style-type: none"> <li>• 0x7F = NAD (Broadcast)</li> <li>• 0x05 = PCI (single frame, 5 bytes)</li> <li>• 0x23 = SID for the Read-Memory-By-Address</li> <li>• 0x21 = fixed byte (D1)</li> <li>• 0x27 = Start address of Shadow in RAM</li> <li>• 0x00F8 = byte count = 248 bytes (= 124 words * 2)</li> </ul>	<ACK>
LR_3D008	Read First frame	<ACK>19 1 0F9 63 8000 1900 <ul style="list-style-type: none"> <li>• 0x19 = configured NAD</li> <li>• 0x1 = PCI</li> <li>• 0x0F9 = LENght (= 248 + 1 bytes)</li> <li>• 0x63 = RSID (Read-Mem.-By-Addr.)</li> <li>• 0x80 =Low byte of Shadow addr. 0x00</li> <li>• 0x00 = High byte of Shadow addr. 0x00</li> <li>• 0x19 = Low byte of Shadow addr. 0x01</li> <li>• 0x00 = High byte of Shadow addr. 0x01</li> </ul>
LR_3D008	Read Consecutive frame 1	<ACK>19 1 0F9 63 8000 1900 <ul style="list-style-type: none"> <li>• 0x19 = configured NAD;</li> <li>• 0x1 = PCI</li> <li>• 0x0F9 = LENght (= 248 + 1 bytes)</li> <li>• 0x63 = RSID (Read-Mem.-By-Addr.)</li> <li>• 0x80 =Low byte of Shadow addr. 0x00</li> <li>• 0x00 = High byte of Shadow addr. 0x00</li> <li>• 0x19 = Low byte of Shadow addr. 0x01</li> <li>• 0x00 = High byte of Shadow addr. 0x01</li> </ul>
LR_3D008	Read Consecutive frame 2	<ACK>19 2 2 00 19 00 00 00 00 <ul style="list-style-type: none"> <li>• 0x19 = NAD; 0x2 = PCI</li> <li>• 0x2 = Frame count = 2;</li> <li>• ..data bytes</li> </ul>
..	..	..
LR_3D008	Read Consecutive frame 15	<ACK>19 2 F 00 00 00 00 00 40 <ul style="list-style-type: none"> <li>• 0x19 = NAD; 0x2 = PCI</li> <li>• 0xF = Frame count = 15;</li> <li>• ..data bytes</li> </ul>
LR_3D008	Read Consecutive frame 16	<ACK>19 2 0 00 00 00 00 00 <ul style="list-style-type: none"> <li>• 0x19 = NAD; 0x2 = PCI</li> <li>• 0x0 = Frame count = 0 (restart count);</li> <li>• .. data bytes</li> </ul>
..	..	..
LR_3D008	Read Consecutive frame 31	<ACK>19 2 F 00 00 00 00 00 00 <ul style="list-style-type: none"> <li>• 0x19 = NAD; 0x2 = PCI;</li> <li>• 0xF = Frame count = 15;</li> <li>• .. data bytes</li> </ul>
..	..	..
LR_3D008	Read Consecutive frame 41	<ACK>19 2 9 00 00 11 03 FFFF <ul style="list-style-type: none"> <li>• 0x19 = NAD; 0x2 = PCI;</li> <li>• 0x9 = Frame count = 9;</li> <li>• 0x00 = Low byte of Shadow addr. 0x7A</li> <li>• 0x00 =High byte of Shadow addr. 0x7A</li> <li>• 0x11 = Low byte of Shadow addr. 0x7B</li> <li>• 0x03 = High byte of Shadow addr.0x7B</li> </ul>
LW_3C0087F02B403FFFFFFFF	Send "Start Measurement and Conditioning Cycle from Shadow Memory" (0x03)	<ACK>

Command	Description	Expected Response (Example)
LW_3C0087F05232100004EFF	Read Output Memory content from RAM via LIN "Read-Memory-By-Address" service (SID 0x23) with OutMem start address in RAM = 0x00, byte count: 0x004E (78 bytes = 39 words * 2)	<ACK>
LR_3D008	Read First frame	<ACK>19 1 04F 63 0100 780B <ul style="list-style-type: none"> <li>• 0x19 = configured NAD;</li> <li>• 0x1 = PCI</li> <li>• 0x0F9 = LENght (= 248 + 1 bytes)</li> <li>• 0x63 = RSID (Read-Mem.-By-Addr.)</li> <li>• 0x0001 = data OutMem addr. 0x00</li> <li>• 0x0B78 = data OutMem addr. 0x01</li> </ul>
LR_3D008	Read Consecutive frame 1	<ACK>19 2 1 0100 EC36 0100 <ul style="list-style-type: none"> <li>• 0x19 = NAD; 0x2 = PCI;</li> <li>• 0x1 = Frame count = 1;</li> <li>• 0x0001 = data OutMem addr. 0x02</li> <li>• 0x36EC = data OutMem addr. 0x03</li> <li>• 0x0001 = data OutMem addr. 0x04</li> </ul>
..	..	..
LR_3D008	Read Consecutive frame 13	<ACK> 19 2 D 0000 FFFF FFFF <ul style="list-style-type: none"> <li>• 0x19 = NAD; 0x2 = PCI;</li> <li>• 0x9 = Frame count = 13;</li> <li>• 0x0000 = data OutMem addr. 0x26</li> <li>• 0xFFFF FFFF = unused bytes filled</li> </ul>
LW_3C0087F02B407FFFFFFFFF	Send "Stop Run"(0x07) of measurement cycle via LIN Data-Dump service (SID 0xB4)	<ACK>
LW_3C0087F04B4096400FFFF  (TWAITxxxxx) LR_3D008	Send "Start Measurement" (0x09) with Averaging = 8 samples, auto-zero compensation = enabled, using normal operation measurement cycle from Shadow (consider wait time for execution, but <1s) Read command response (1 byte)  -> when finished, the averaged measurement results can be read from Output memory section in RAM	<ACK>  <ACK>1904F4090909FFFF <ul style="list-style-type: none"> <li>• 0x090909 = successful finished</li> <li>• (0x000000 = in execution)</li> </ul>



Command	Description	Expected Response (Example)
LW_3C0087F10FD3D212700F8	Write Shadow Memory content to RAM <sup>[a]</sup> via LIN "Write-Memory-By-Address" service (SID 0x3D) <ul style="list-style-type: none"> <li>• 0x7F = NAD (Broadcast)</li> <li>• 0x1 = PCI</li> <li>• 0x0FD = 253 bytes to write (= 124 words * 2 + 5)</li> <li>• 0x3D = SID for the Write-Memory-By-Address</li> <li>• 0x21 = fixed byte (D1)</li> <li>• 0x27 = Start address of Shadow in RAM</li> <li>• 0x00F8 = byte count = 248 bytes (= 124 words * 2)</li> </ul>	<ACK>
LW_3C0087F2180001900480F	Write Consecutive frame 1 <ul style="list-style-type: none"> <li>• 0x7F = NAD (Broadcast);</li> <li>• 0x2 = PCI</li> <li>• 0x1 = frame count = 1</li> <li>• 0x80 = Low byte of Shadow addr. 0x00</li> <li>• 0x00 = High byte of Shadow addr. 0x00</li> <li>• 0x19 = Low byte of Shadow addr. 0x01</li> <li>• 0x00 = High byte of Shadow addr. 0x01</li> <li>• 0x48 = Low byte of Shadow addr. 0x02</li> <li>• 0x0F = High byte of Shadow addr. 0x02</li> </ul>	<ACK>
LW_3C0087F22000000000019	Write Consecutive frame 2 <ul style="list-style-type: none"> <li>• 0x7F = NAD (Broadcast);</li> <li>• 0x2 = PCI</li> <li>• 0x2 = frame count = 2</li> <li>• 0x00/00 = Low/High byte of Shadow addr. 0x03</li> <li>• 0x00/00 = Low/High byte of Shadow addr. 0x04</li> <li>• 0x00/19 = Low/High byte of Shadow addr. 0x05</li> </ul>	<ACK>
..	..	..
LW_3C0087F2F0010B0000000	Write Consecutive frame 15 <ul style="list-style-type: none"> <li>• 0x7F = NAD; 0x2 = PCI;</li> <li>• 0xF = Frame count = 15;</li> <li>• ..data bytes</li> </ul>	<ACK>
LW_3C0087F20000000400000	Write Consecutive frame 16 <ul style="list-style-type: none"> <li>• 0x7F = NAD; 0x2 = PCI;</li> <li>• 0x0 = Frame count = 0 (restart count with "0");</li> <li>• .. data bytes (0x0000, 0x4000, 0x0000)</li> </ul>	<ACK>
..	..	..
LW_3C0087F2F000000000000	Write Consecutive frame 31 <ul style="list-style-type: none"> <li>• 0x7F = NAD; 0x2 = PCI;</li> <li>• 0xF = Frame count = 15;</li> <li>• ..data bytes (0x0000, 0x0000, 0x0000)</li> </ul>	<ACK>
..	..	..
LW_3C0087F2A1103FFFFFFFFF	Write Consecutive frame 41 <ul style="list-style-type: none"> <li>• 0x7F = NAD (Broadcast);</li> <li>• 0x2 = PCI</li> <li>• 0xA = frame count = 10</li> <li>• 0x11/03 = Low/High byte of Shadow addr. 0x7B</li> <li>• 0xFFFFFFFF = unused bytes filled with 0xFF</li> </ul>	<ACK>
LW_3C0087F04B4153C5BFFFF	Send "Write NVM Write Authorization" (0x15) with NVM Write Authorization Key 0x3C5B via LIN Data-Dump service (SID 0xB4)	<ACK>
LW_3C0087F02B414FFFFFFFFF \	Send "Read NVM Write Authorization Status" (0x14) via LIN Data-Dump service (SID 0xB4)	<ACK> \

Command	Description	Expected Response (Example)
LR_3D008	Read command response	1904F4140001FFFF <ul style="list-style-type: none"> <li>• 0x14 = command response (success)</li> <li>• 0x0001 = NWM Write Enabled</li> </ul>
LW_3C0087F04B41A0007FFFF \ TWAIT744 \ LR_3D008	Send "Copy Shadow Memory to NVM" (0x20) with all pages (ShdwPgLinObd, ShdwPgApplCfg, ShdwPgLinId) selected and CRCs calculated  Wait $\approx 744$ ms (= 124 register * 6ms NVM programming time (max)); <1s  Read command response	<ACK>  \  \<<ACK>1904F41A0000FFFF <ul style="list-style-type: none"> <li>• 0x1A 0000 = command response (success)</li> </ul> -> NVM successfully written
LW_3C0087F02B401FFFFFFFF	Send "Start Normal Mode"	<ACK>

[a] Do not change calibrated parameters! For details, please check Memory Allocation document.

### 2.5.3. Command Script (Example)

```
# Check SSC-Communication Board connection, read firmware and hardware version
V
V_HW

# Setup Trigger (KS12V, KS5V, 50ms communication delay)
T11050

# Set LIN interface settings
LO_20000001

# Triggered Power-ON + Start Command Mode - via LIN Data-Dump (SID 0xB4)
LWT3C0087F04B4727EA9FFFF
# Read Command Response
LR_3D008

# Send: ClrOutMem
LW_3C0087F02B41FFFFFFFF
# check response
LR_3D008

# Send: StrtMeasCyc sequence with - short with only mandatory argument:
# settings: Avg=2(4 samples), CpShdwCfgDis=0(ShadowSettingsCopiedToRegisters),
InfiniteCycling=0(disabled), AzEna=1(enabled), MeasCycMd=0(normal)
LW_3C0087F04B4094400FFFF

# # Read OutMem - via LIN Read-Memory-By-Address (SID 0x23)
# Read Averaged Raw Measurement Results for BRS, T1, T2, RPTAT
LW_3C0087F0523210000CFF
LR_3D008
LR_3D008
LR_3D008
```

## 2.6 “MEMORY EDIT” Application Tab

The “MEMORY EDIT” tab shows the current state of the chip memory.

It allows the user to edit and write memory contents. All the fields in blue color (NVM and Output memory) are read-only registers. Changing values directly to the memory can be done by entering the new hexadecimal value in the grid box of the corresponding address. The new content must be updated in the chip by clicking the “Write Shadow” button. The “Copy Shadow to NVM” button copies the content of the Shadow memory to NVM and updates the CRCs.

The display grid updates automatically when the settings changes in the “CONFIGURE” and “CALIBRATION” application tabs; the values that are not yet written in the chip memory are shown in red. Note that these values are not written automatically in the ZSSC4132 memory, to do this, click “Write Shadow” button.

If a register is modified, the indicator in the bottom right corner of the window becomes red as shown on Figure 36. If the content in the table is the same as the content read at the last reading, the indicator stays green.



**Figure 36. Memory Indicator: Modified Content**

The data is displayed as hexadecimal (16 bits) for each address in the memory.

Registers names of each address are displayed if you hover the mouse cursor over the corresponding grid box.

To display the actual DUT memory contents in the table, read the complete memory by clicking on the “Read Shadow”, “Read Output”, and “Read NVM” buttons.

Shadow	0	1	2	3	4	5	6	7
0h	C180	0019	9B69	0000	0000	1900	0000	0000
8h	0842	150D	291D	3931	004C	0000	0000	0000
10h	0000	0000	0000	0000	24F4	01E4	0024	8FFF
18h	0008	2300	0075	17E2	C0A2	C822	6789	1722
20h	3000	0000	0002	0000	0000	0000	0000	0000
28h	0000	0000	1000	00B0	0000	0000	4000	0000
30h	0000	0000	0000	0000	0000	0000	0000	1000
38h	00B0	0000	0000	4000	0000	00B0	0000	4000
40h	0000	0000	2000	0000	4000	0000	78DE	4444
48h	0000	0000	7FFF	0000	7FFF	0000	7FFF	FF00
50h	FF00	FF00	FFFF	FF00	FF00	FF00	FF00	FF00
58h	FF00	BC96	0000	0000	0000	0000	0000	0000
60h	0000	0000	0000	0000	0000	0000	0000	0000
68h	0000	0000	0000	0000	0000	0000	0000	0000
70h	0000	0000	0000	0000	0000	0000	0000	0000
78h	0000	0000	0000	0311				

**Figure 37. “MEMORY EDIT” Tab – Shadow Memory**

By clicking the “Start Read Output Memory Continuously” button, a continuous measurement cycle from Shadow is started and the content of the output memory will be read continuously.

Activating the checkbox “Output memory in decimal format” shows values as decimal.

Output	0	1	2	3	4	5	6	7
0h	1	5838	1	14112	1	16130	0	0
8h	16384	0	5838	14112	16130	0	0	0
10h	5860	0	4118	0	14180	0	2116	16190
18h	2108	0	0	0	0	0	0	0
20h	0	0	0	0	0	128	0	

Start Read Output Memory Continuously  Output memory in decimal format

Register values in red are different from the previous memory in order to take effect.

Click to start reading Output memory continuously

Figure 38. "MEMORY EDIT" Tab – Output Memory (Decimal)

## 2.7 Tools

Clicking on the “TOOLS” menu, see Figure 39, the following options will be provided:

- Open the Log files for:
  - Error: includes general error logging events (for example, calibration error)
  - Communication: includes communication logs with the evaluation kit and IC
  - Calibration: includes calibration logging information
- Open the Log file folder: to open the logging folder in an explorer window.

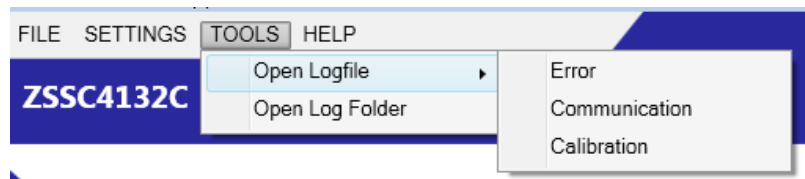

Figure 39. TOOLS Menu Options

## 2.8 Help

Clicking on the “HELP” menu, see Figure 40, the following options will be provided:

- “Show License” agreement: to show the license agreement and disclaimer information that was also agreed at the installation process.
- Click “About” window: to show a pop-up window with information about the GUI revision, release date, FTDI driver version, and communication board firmware revision. This information is useful, when support on the GUI is required.

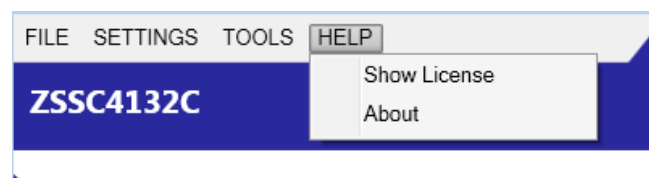

Figure 40. HELP Menu Options

### 3. Schematics

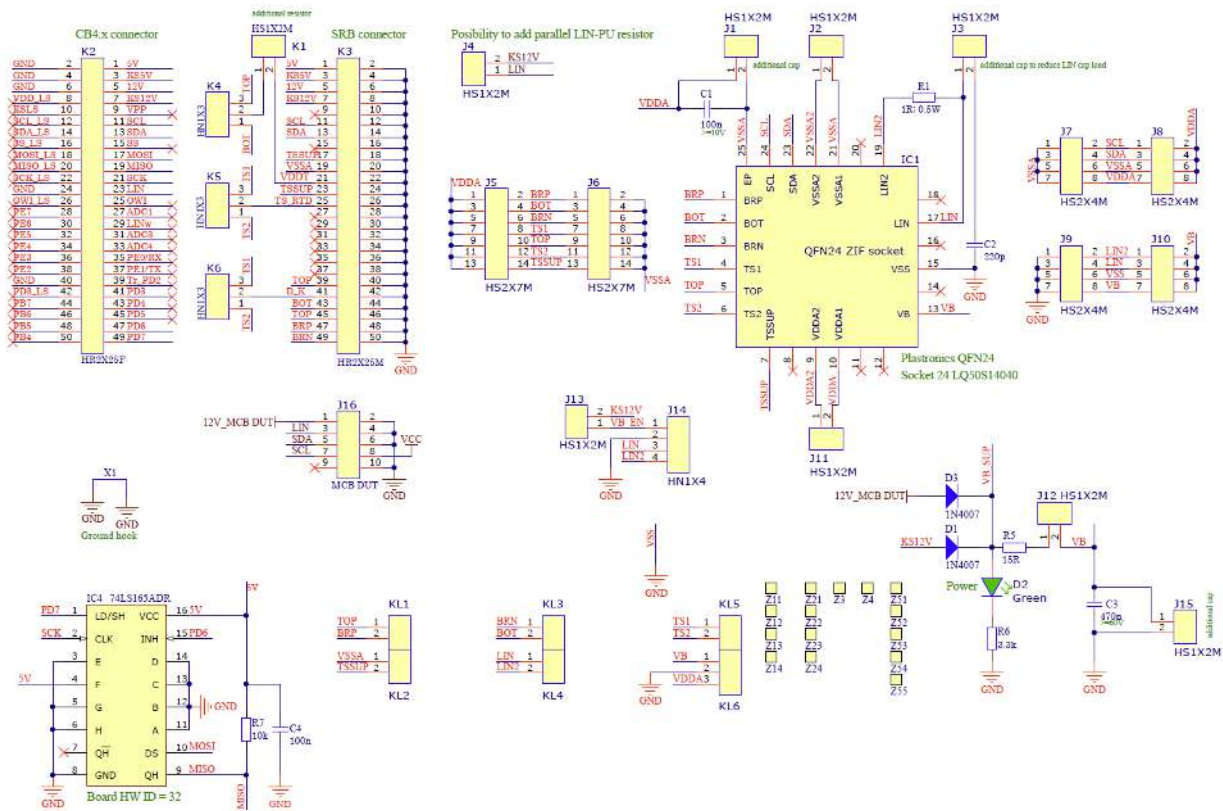

Figure 41. Schematic – ZSSC4132 Evaluation Board: ZSSC4132EVB\_Rev.1 (20Feb2020)

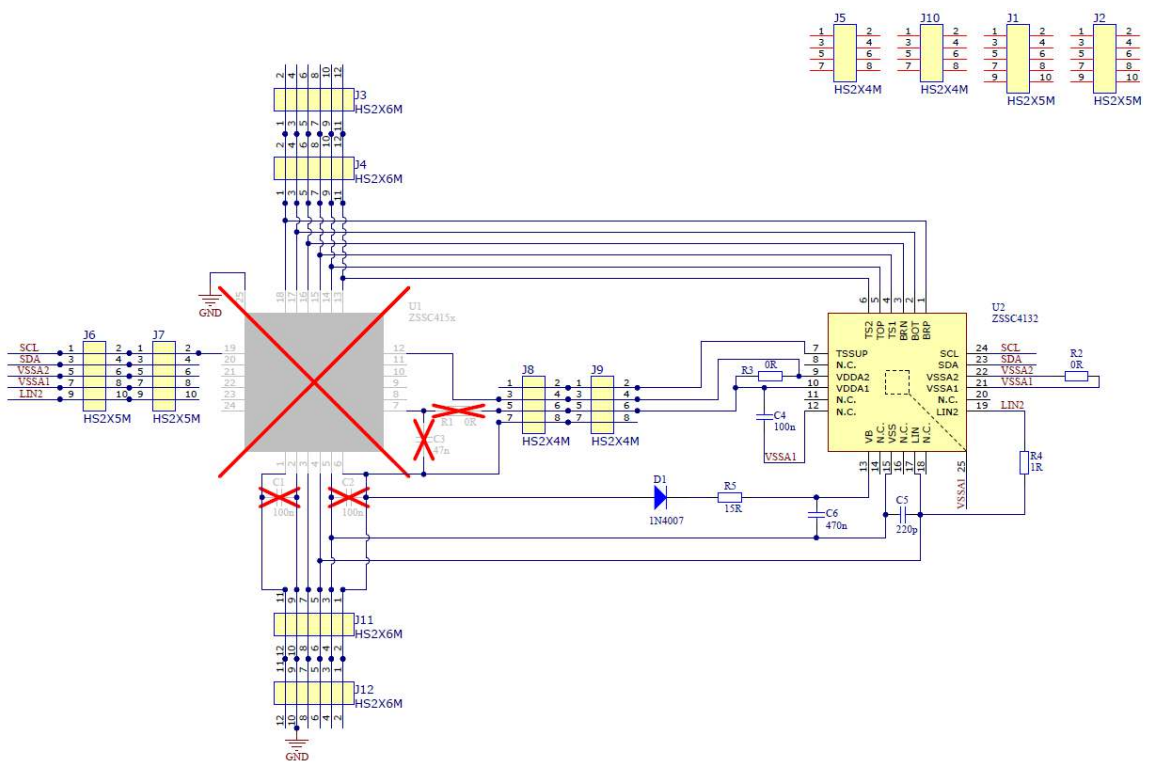

Figure 42. Schematic – ZSSC4132 Sample Board: ZSSC41xxSB\_Rev.1 (20Feb2020); Bottom (ZSSC4132)

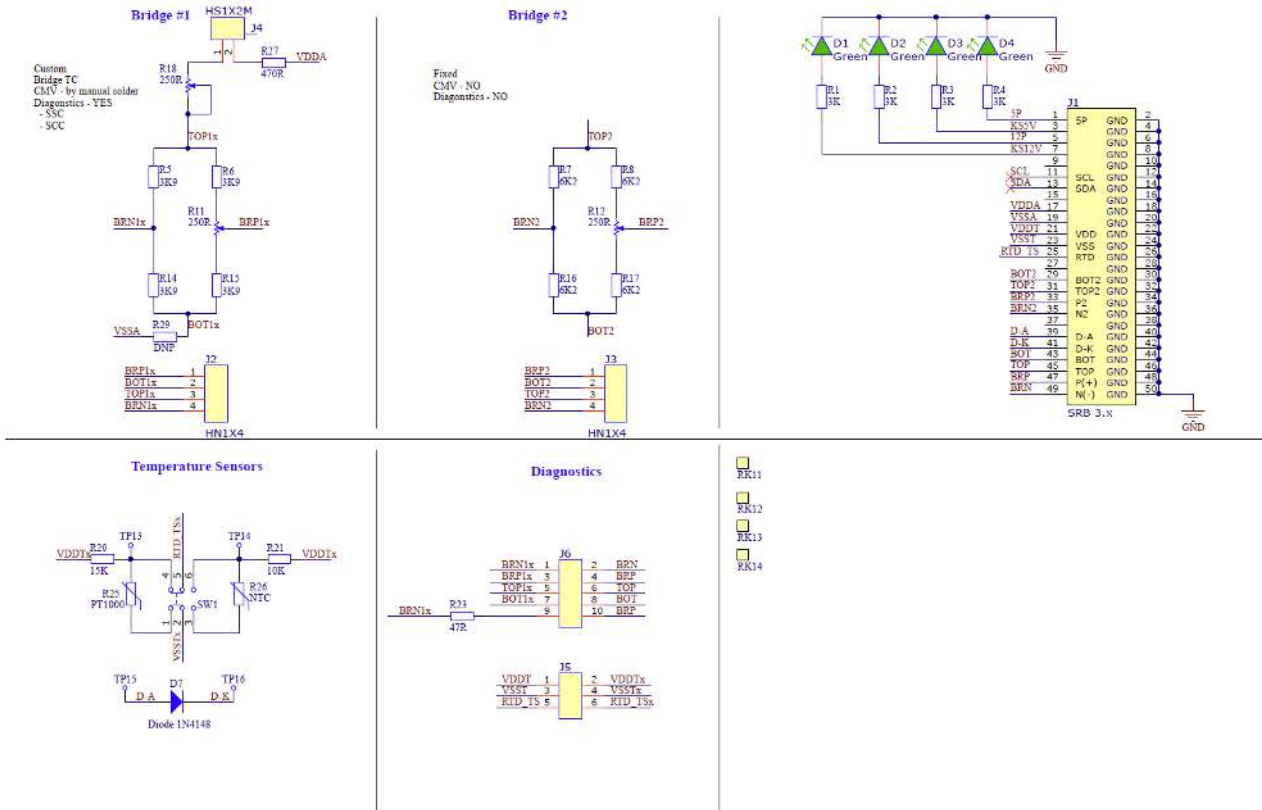

Figure 43. Schematic – Sensor Replacement Board: SSCSRBV3\_Rev.1 (20Feb2020)



## 4. Bill of Materials (BOM)

Table 12. BOM - ZSSC4132 Evaluation Board: ZSSC4132EVB, Rev.1, 20Feb2020

Designator	Value	Package	Description	Manufacturer P/N	Manufacturer	Qty.
C1, C4	100 nF	0603	CAP SMD 0603, 100 nF, 25 V, X7R, +-10%	VJ0603Y104KXXPW1BC	VISHAY	2
C2	220 pF	0603	CAP SMD 0603, 220 pF, 50 V, COG, +-5%, 30ppm	GRM1885C1H221JA01D	MURATA ELECTRONICS	1
C3	470 nF	0603	CAP SMD 0603, 0.47 $\mu$ F, 16 V, X7R, $\pm$ 5%, C Series	C0603C474J4RACTU	KEMET	1
D1, D3	1N4007	SMA	Diode, 1000 V, 1 A, UFM1.1V/1A, IFM30A, IR5 $\mu$ A	M7	SM TECHNOLOGY	2
D2	LED Green	0805	LED, 2.0x1.25 mm, 450 mcd/20mA, 525 nm True Green, 120°	OSG50805C1E	OPTOSUPPLY INTERNATIONAL	1
IC1		24-QFN Socket	ZIF socket, 24-QFN	24LQ50S14040-E	PLASTRONICS	1
IC4		SOP-16	CMOS High Speed Logic - 74HC/AHC/AC Series	74HC165D	NEXPERIA	1
J1, J2, J3, J4, J11, J12, J13, J15, K1	Header 1x2	HS1X2M	Board to Board/Wire Header, contact height 6.0mm, 1x2, straight PCB TH, P2.54mm	CH31022V200	CVILUX	9
J5, J6	Header 2x7	HS2X7M	Board to Board/Wire Header, contact height 6.0mm, 2x7(40), straight PCB TH, P2.54mm	CH81802V200 (cut)	CVILUX	2
J7, J8, J9, J10	Header 2x4	HS2X4M	Board to Board/Wire Header, contact height 6.0mm, 2x4(40), straight PCB TH, P2.54mm	CH81802V200 (cut)	CVILUX	4
J14	Header 1x4	HN1X4	Board to Board/Wire Header, contact height 6.0mm, 1x4, straight PCB TH, P2.54mm	CH31042V200	CVILUX	1
J16	Header 2x4	BH10S	Box Header Connector 2x5	CH87102V200	CVILUX	1
K2	Socket 2x25	HR2X25F	BL 2X25W 2,54, 2x 25-pin socket terminal strip, angled, RM 2.54	BL 2X25W 2,54	Reichelt	1
K3	Header 2x25	HR2X25M	SL 2X25W 2,54, 2 x 25-pin header, angled, pitch 2.54	SL 2X25W 2,54	Reichelt	1
K4, K5, K6	Header 1x3	HN1X3	Board to Board/Wire Header, contact height 6.0mm, 1x3, straight PCB TH, P2.54mm	CH31032V200	CVILUX	3
KL1, KL2, KL3, KL4, KL5	-	DG350-3.5-02P	Screw terminal, 2 port, 10A 300V AC AWG24-18 3.5mm	DG350-3.5-02P-14-00AH	DEGSON	5
KL6	-	DG350-3.5-03P	Screw terminal, 3 port, 10A 300V AC AWG24-18 3.5mm	DG350-3.5-03P-14-00AH	DEGSON	1
R1	1 $\Omega$	1206	RES SMD 1206, Thick film, 1R, 1 %, 0.5 W, MCWF12P Series, 200 V	MCWF12P1R00FTL	Multicomp Pro	1
R5	15 $\Omega$	0603	RES SMD 0603, 15R, 1%, 100ppm, 1/10W	RC0603FR-0715RL	YAG/ASJ	1
R6	3.3 k $\Omega$	0603	RES SMD 0603, 3.3K, 1%, 100ppm, 1/10W	RC0603FR-073K3L	YAG/ASJ	1
R7	10 k $\Omega$	0603	RES SMD 0603, 10K, 1%, 100ppm, 1/10W	RC0603FR-0710KL	YAG/ASJ	1

Designator	Value	Package	Description	Manufacturer P/N	Manufacturer	Qty.
X1	-	10.16mm	D3082F05 - Track Pin, Uninsulated, Shorting Link, 0.4", 25 Pack	D3082F05 (cut)	HARWIN	1
-	-	W:102mm; L:152mm	ESD Bag; open; W: 102mm; L: 152mm; D: 50um	ERS-207710406	EUROSTAT GROUP	1
-	-	3mm	PD.2075BL - Bumper / Feet, Stick On, Pack 60, Adhesive, PU (Polyurethane), 3 mm, Round, Black	PD.2075BL(cut)	MULTICOMP	4
-	-	2.54, 6mm	Jumper 2.54; h 6mm	CS01602B100	CVILUX	8

Table 13. BOM – Sensor Replacement Board: SSCSRBV3, Rev.1, 20Feb2020

Designator	Value	Package	Description	Manufacturer P/N	Manufacturer	Qty.
D1, D2, D3, D4	LED Green	0805	LED, 2.0x1.25 mm, 450 mcd/20mA, 525 nm True Green, 120°	OSG50805C1E	OPTOSUPPLY INTERNATIONAL	4
D7	Diode 1N4148	SOD-123	Diode 1N4148, 100V, 150mA, 4ns, 2pF	1N4148W	DIODES/ZETEX	1
J1	Socket 2x25	HR2X25F	BL 2X25W 2,54, 2x 25-pin socket terminal strip, angled, RM 2.54	BL 2X25W 2,54	Reichelt	1
J2, J3	Header 1x4	HN1X4	Board to Board/Wire Header, contact height 6.0mm, 1x4, straight PCB TH, P2.54mm	CH31042V200	CVILUX	2
J4	Header 1x2	HN1X2	Board to Board/Wire Header, contact height 6.0mm, 1x2, straight PCB TH, P2.54mm	CH31022V200	CVILUX	1
J5	Header 2x3	HS2X3M	Board to Board/Wire Header, contact height 6.0mm, 2x3(40), straight PCB TH, P2.54mm	CH81802V200 (cut)	CVILUX	1
J6	Header 2x5	HS2X5M	Board to Board/Wire Header, contact height 6.0mm, 2x5(40), straight PCB TH, P2.54mm	CH81802V200 (cut)	CVILUX	1
R1, R2, R3, R4	3.0 kΩ	0805	RES SMD 0805, 3.0K, 1%, 100ppm, 1/8W	0805S8F0302T50	UNI OHM	4
R5, R6, R14, R15	3.9 kΩ	0805	RES SMD 0805, 3.9K, 1%, 100ppm, 1/8W	RC0805FR-073K9L	YAG/ASJ	4
R7, R8, R16, R17	6.2 kΩ	0805	RES SMD 0805, 6.2K, 1%, 100ppm, 1/8W	0805S8F0622T50	UNI OHM	4
R11, R12, R18	250 Ω	Rtrim_PT10	Trimmer Resistor – Through-hole, 250 Ohm, 10mm, Rnd, Top adj	531-PT10MV-250	AMPHENOL PIHER	3
R20	15 kΩ	0805	RES SMD 0805, 15K, 1%, 100ppm, 1/8W	RC0805FR-0715KL	YAG/ASJ	1
R21	10 kΩ	0805	RES SMD 0805, 10K, 1%, 100ppm, 1/8W	RC0805FR-0710KL	YAG/ASJ	1
R23	47 Ω	0805	RES SMD 0805, 47R, 1%, 200ppm, 1/8W	0805S8F0470T50	UNI OHM	1
R25	PT1000	0805	RTD Sensor PT1000, Class B, 0805, -50 °C, +150 °C, 1 kohm	P1K0.0805.1FC.B.S	IIST	1
R26	NTC_10K	0805	Thermistor, NTC, 10 kohm, B57620C5 Series, 3730 K, SMD	B57620C5103J062	EPCOS	1
R27	470 Ω	0805	RES SMD 0805, 470R, 1%, 100ppm, 1/8W	RC0805FR-07470RL	YAG/ASJ	1

Designator	Value	Package	Description	Manufacturer P/N	Manufacturer	Qty.
R29	DNP	0805	RES SMD 0805	-	-	1
RK11, RK12, RK18	-	-	Thumbwheel for Piher pot. PT10M,G, diam. 11.5mm, H=6mm, green	PT10M,G-THUMBWHEEL	AMPHENOL PIHER	3
SW1	switch	CL-SB-22B	CL-SB-22B-01T - Slide Switch, DPDT, Surface Mount, CL-SB Series, 200 mA	CL-SB-22B-01T	Nidec	1
TP13, TP14, TP15, TP16	DNP	-	Test point	-	-	4
-	-	W:102mm; L:152mm	ESD Bag; open; W: 102mm; L: 152mm; D: 50um	ERS-207710406	EUROSTAT GROUP	1
-	-	3mm	PD.2075BL - Bumper / Feet, Stick On, Pack 60, Adhesive, PU (Polyurethane), 3 mm, Round, Black	PD.2075BL(cut)	MULTICOMP	2
-	-	2.54, 6mm	Jumper 2.54; h 6mm	CS01602B100	CVILUX	9

Table 14. BOM – ZSSC4132 Sample Board: ZSSC41xxSB, Rev.1, 20Feb2020 – Bottom Layer (ZSSC4132)

Designator	Value	Package	Description	Manufacturer P/N	Manufacturer	Qty.
C4	100 nF	0603	CAP SMD 0603, 100nF, 25V, X7R, +-10%	VJ0603Y104KXXPW1BC	VISHAY	1
C5	220 pF	0603	CAP SMD 0603, 220pF, 100V, COG, +-5%	MC0603N221J101CT	MULTICOMP	1
C6	470 nF	0805	CAP SMD 0805, 0.47μF, 100 V, ± 10%, X7R	08051C474KAT2A	AVX	1
D1	1N4007	SMA	Diode, 1000V, 1A, UFM1.1V/1A, IFM30A, IR5uA	1N4007(M7)	SM TECHNOLOGY	1
R2, R3	0 Ω	0603	RES SMD 0603, JUMPER, MAX 50mOhm	0603SAJ000JT50	UNI OHM	2
R4	1 Ω	1206	RES SMD 1206, 1 ohm, MCWF12P Series, 200 V, Thick Film, 500 mW	MCWF12P1R00FTL	MULTICOMP	1
R5	15 Ω	0603	RES SMD 0603, 15R, 1%, 100ppm, 1/10W	RC0603FR-0715RL	YAG/ASJ	1
U2	ZSSC4132C	24-QFN	IC, Sensor Signal Conditioner, ZSSC4132C	ZSSC4132CE4R	Renesas (IDT)	1
-	-	W: 50mm; L: 101mm	ESD Bag; metallized, open; W: 50mm; L: 101mm	10024	SCS	1
J6, J7	DNP	HS2X5M	2x5-pin header, vertical, P2.54 mm	CH81402V200	CVILUX	2
J3, J4, J11, J12	DNP	HS2X6M	2x6-pin header, vertical, P2.54 mm	CH81402V200	CVILUX	4
J8, J9	DNP	HS2X4M	2x4-pin header, vertical, P2.54 mm	CH81402V200	CVILUX	2

### 5. Board Layout

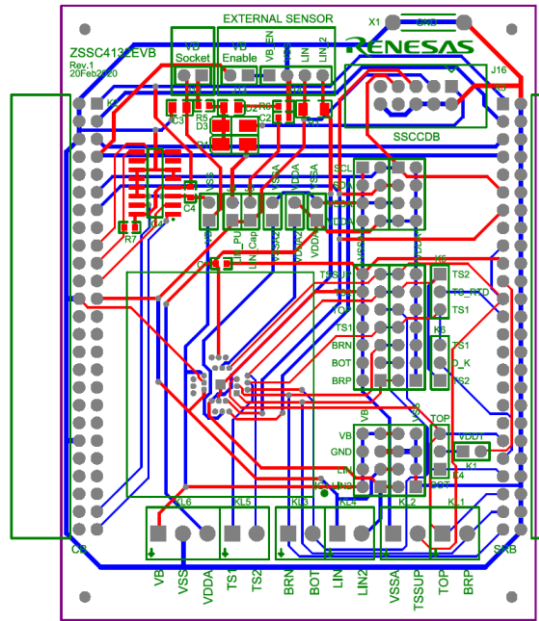

Figure 44. Layout - ZSSC4132 Evaluation Board: ZSSC4132EVB, Rev.1, 20Feb2020 – Top/Bottom Layer

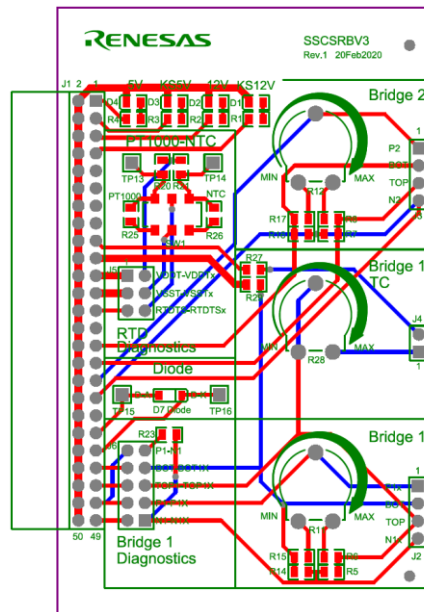

Figure 45. Layout - Sensor Replacement Board: SSSCRVB3, Rev.1, 20Feb2020 – Top/Bottom Layer

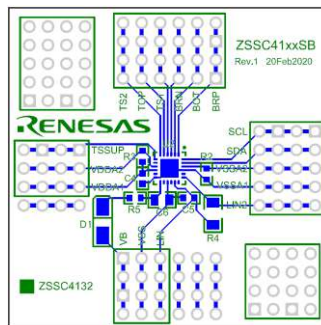

Figure 46. Layout - ZSSC4132 Sample Board: ZSSC41xxSB, Rev.1, 20Feb2020 – Bottom Layer ZSSC4132

## 6. Related Documents and Software Locations

Visit the following product pages on Renesas's website [www.IDT.com](http://www.IDT.com) to download the latest version of the ZSSC4132 Evaluation Software, related documents, and the latest version of this document, or contact Renesas via the contact information on the last page.

- Product page: [www.IDT.com/ZSSC4132](http://www.IDT.com/ZSSC4132)
- Kit product page: [www.IDT.com/ZSSC4132KIT](http://www.IDT.com/ZSSC4132KIT)
- SSC Communication Board: [www.IDT.com/SSC-CB](http://www.IDT.com/SSC-CB)

## 7. Glossary

Term	Description
ADC	Analog-to-Digital Converter
Addr.	Address
AFE	Analog Frontend
BOM	Bill Of Material
BRS	Bridge Sensor
BRSC	Bridge Sensor Connection
BSM	Bus Shunt Method (LIN)
CB	Communication Board
CMC	Calibration Microcontroller
CmdMd	Command Mode
CRC	Cyclic Redundancy Check
DEC	Decimal
DLL	Dynamic Link Library
DUT	Device Under Test
EB, EVB	Evaluation Board
GUI	Graphical User Interface – refers to the software application used for communication with the kit
HEX, hex	Hexadecimal
I2C	Inter-Integrated Circuit; serial two-wire data bus; trademark of NXP
IC	Integrated Circuit
LED	Light Emitting Diode
LIN	Local Interconnect Network
LSB	Least Significant Bit
MCU	Microcontroller Unit
MRF	Master Request Frame (LIN)
MSB	Most Significant Bit
MTP	Multiple Times Programmable (Memory)
NAD	Node Address (LIN)
NOM	Normal Operation Mode
NTC	Negative Temperature Coefficient
NVM	Non-Volatile Memory
PC	Personal Computer
PCB	Printed Circuit Board
PCI	Protocol Control Information (LIN)
PGA	Programmable Gain Amplifier
PID	Protected Identifier (LIN)
PTAT	Proportional To Absolute Temperature (IC internal temperature)
PTC	Positive Temperature Coefficient
(P)QFN	(Power) Quad Flat No-lead (device package)
RAM	Random Access Memory (Volatile Memory for Configuration and Conditioning Coefficients)
RSID	Response Service Identifier (LIN)
RTD	Resistance Temperature Device/Detector
SID	Service Identifier (LIN)
SMD	Surface-Mounted Device
SNPD	Slave Node Position Detection (LIN)
SRB	Sensor Replacement Board
SSC	Sensor Signal Conditioner

Term	Description
SSC-CB	SSC communication board
SSC-EB	SSC Evaluation Board ZSSC4132
SSC-SRB	SSC Sensor Replacement Board
TC	Temperature Coefficient
TSC	Temperature Sensor Check
USB	Universal Serial Bus

## 8. Ordering Information

Orderable Part Number	Description
ZSSC4132KIT	ZSSC4132 SSC Evaluation Kit - including: SSC Communication Board, ZSSC4132 Evaluation Board, Sensor Replacement Board, ZSSC4132 Sample Board, USB Cable A-Male to B-Male, 5 sample ZSSC4132, tweezers

## 9. Revision History

Date	Description
Jun.3.20.	Initial release.



## Notice

1. Descriptions of circuits, software and other related information in this document are provided only to illustrate the operation of semiconductor products and application examples. You are fully responsible for the incorporation or any other use of the circuits, software, and information in the design of your product or system. Renesas Electronics disclaims any and all liability for any losses and damages incurred by you or third parties arising from the use of these circuits, software, or information.
  2. Renesas Electronics hereby expressly disclaims any warranties against and liability for infringement or any other claims involving patents, copyrights, or other intellectual property rights of third parties, by or arising from the use of Renesas Electronics products or technical information described in this document, including but not limited to, the product data, drawings, charts, programs, algorithms, and application examples.
  3. No license, express, implied or otherwise, is granted hereby under any patents, copyrights or other intellectual property rights of Renesas Electronics or others.
  4. You shall not alter, modify, copy, or reverse engineer any Renesas Electronics product, whether in whole or in part. Renesas Electronics disclaims any and all liability for any losses or damages incurred by you or third parties arising from such alteration, modification, copying or reverse engineering.
  5. Renesas Electronics products are classified according to the following two quality grades: "Standard" and "High Quality". The intended applications for each Renesas Electronics product depends on the product's quality grade, as indicated below.
    - "Standard": Computers; office equipment; communications equipment; test and measurement equipment; audio and visual equipment; home electronic appliances; machine tools; personal electronic equipment; industrial robots; etc.
    - "High Quality": Transportation equipment (automobiles, trains, ships, etc.); traffic control (traffic lights); large-scale communication equipment; key financial terminal systems; safety control equipment; etc.
- Unless expressly designated as a high reliability product or a product for harsh environments in a Renesas Electronics data sheet or other Renesas Electronics document, Renesas Electronics products are not intended or authorized for use in products or systems that may pose a direct threat to human life or bodily injury (artificial life support devices or systems; surgical implantations; etc.), or may cause serious property damage (space system; undersea repeaters; nuclear power control systems; aircraft control systems; key plant systems; military equipment; etc.). Renesas Electronics disclaims any and all liability for any damages or losses incurred by you or any third parties arising from the use of any Renesas Electronics product that is inconsistent with any Renesas Electronics data sheet, user's manual or other Renesas Electronics document.
6. When using Renesas Electronics products, refer to the latest product information (data sheets, user's manuals, application notes, "General Notes for Handling and Using Semiconductor Devices" in the reliability handbook, etc.), and ensure that usage conditions are within the ranges specified by Renesas Electronics with respect to maximum ratings, operating power supply voltage range, heat dissipation characteristics, installation, etc. Renesas Electronics disclaims any and all liability for any malfunctions, failure or accident arising out of the use of Renesas Electronics products outside of such specified ranges.
  7. Although Renesas Electronics endeavors to improve the quality and reliability of Renesas Electronics products, semiconductor products have specific characteristics, such as the occurrence of failure at a certain rate and malfunctions under certain use conditions. Unless designated as a high reliability product or a product for harsh environments in a Renesas Electronics data sheet or other Renesas Electronics document, Renesas Electronics products are not subject to radiation resistance design. You are responsible for implementing safety measures to guard against the possibility of bodily injury, injury or damage caused by fire, and/or danger to the public in the event of a failure or malfunction of Renesas Electronics products, such as safety design for hardware and software, including but not limited to redundancy, fire control and malfunction prevention, appropriate treatment for aging degradation or any other appropriate measures. Because the evaluation of microcomputer software alone is very difficult and impractical, you are responsible for evaluating the safety of the final products or systems manufactured by you.
  8. Please contact a Renesas Electronics sales office for details as to environmental matters such as the environmental compatibility of each Renesas Electronics product. You are responsible for carefully and sufficiently investigating applicable laws and regulations that regulate the inclusion or use of controlled substances, including without limitation, the EU RoHS Directive, and using Renesas Electronics products in compliance with all these applicable laws and regulations. Renesas Electronics disclaims any and all liability for damages or losses occurring as a result of your noncompliance with applicable laws and regulations.
  9. Renesas Electronics products and technologies shall not be used for or incorporated into any products or systems whose manufacture, use, or sale is prohibited under any applicable domestic or foreign laws or regulations. You shall comply with any applicable export control laws and regulations promulgated and administered by the governments of any countries asserting jurisdiction over the parties or transactions.
  10. It is the responsibility of the buyer or distributor of Renesas Electronics products, or any other party who distributes, disposes of, or otherwise sells or transfers the product to a third party, to notify such third party in advance of the contents and conditions set forth in this document.
  11. This document shall not be reprinted, reproduced or duplicated in any form, in whole or in part, without prior written consent of Renesas Electronics.
  12. Please contact a Renesas Electronics sales office if you have any questions regarding the information contained in this document or Renesas Electronics products.
    - (Note1) "Renesas Electronics" as used in this document means Renesas Electronics Corporation and also includes its directly or indirectly controlled subsidiaries.
    - (Note2) "Renesas Electronics product(s)" means any product developed or manufactured by or for Renesas Electronics.

(Rev.4.0-1 November 2017)

## Corporate Headquarters

TOYOSU FORESIA, 3-2-24 Toyosu,  
Koto-ku, Tokyo 135-0061, Japan  
[www.renesas.com](http://www.renesas.com)

## Contact information

For further information on a product, technology, the most up-to-date version of a document, or your nearest sales office, please visit:  
[www.renesas.com/contact/](http://www.renesas.com/contact/)

## Trademarks

Renesas and the Renesas logo are trademarks of Renesas Electronics Corporation. All trademarks and registered trademarks are the property of their respective owners.

## Notice

1. Descriptions of circuits, software and other related information in this document are provided only to illustrate the operation of semiconductor products and application examples. You are fully responsible for the incorporation or any other use of the circuits, software, and information in the design of your product or system. Renesas Electronics disclaims any and all liability for any losses and damages incurred by you or third parties arising from the use of these circuits, software, or information.
2. Renesas Electronics hereby expressly disclaims any warranties against and liability for infringement or any other claims involving patents, copyrights, or other intellectual property rights of third parties, by or arising from the use of Renesas Electronics products or technical information described in this document, including but not limited to, the product data, drawings, charts, programs, algorithms, and application examples.
3. No license, express, implied or otherwise, is granted hereby under any patents, copyrights or other intellectual property rights of Renesas Electronics or others.
4. You shall be responsible for determining what licenses are required from any third parties, and obtaining such licenses for the lawful import, export, manufacture, sales, utilization, distribution or other disposal of any products incorporating Renesas Electronics products, if required.
5. You shall not alter, modify, copy, or reverse engineer any Renesas Electronics product, whether in whole or in part. Renesas Electronics disclaims any and all liability for any losses or damages incurred by you or third parties arising from such alteration, modification, copying or reverse engineering.
6. Renesas Electronics products are classified according to the following two quality grades: "Standard" and "High Quality". The intended applications for each Renesas Electronics product depends on the product's quality grade, as indicated below.

"Standard": Computers; office equipment; communications equipment; test and measurement equipment; audio and visual equipment; home electronic appliances; machine tools; personal electronic equipment; industrial robots; etc.

"High Quality": Transportation equipment (automobiles, trains, ships, etc.); traffic control (traffic lights); large-scale communication equipment; key financial terminal systems; safety control equipment; etc.

Unless expressly designated as a high reliability product or a product for harsh environments in a Renesas Electronics data sheet or other Renesas Electronics document, Renesas Electronics products are not intended or authorized for use in products or systems that may pose a direct threat to human life or bodily injury (artificial life support devices or systems; surgical implantations; etc.), or may cause serious property damage (space system; undersea repeaters; nuclear power control systems; aircraft control systems; key plant systems; military equipment; etc.). Renesas Electronics disclaims any and all liability for any damages or losses incurred by you or any third parties arising from the use of any Renesas Electronics product that is inconsistent with any Renesas Electronics data sheet, user's manual or other Renesas Electronics document.

7. No semiconductor product is absolutely secure. Notwithstanding any security measures or features that may be implemented in Renesas Electronics hardware or software products, Renesas Electronics shall have absolutely no liability arising out of any vulnerability or security breach, including but not limited to any unauthorized access to or use of a Renesas Electronics product or a system that uses a Renesas Electronics product. RENESAS ELECTRONICS DOES NOT WARRANT OR GUARANTEE THAT RENESAS ELECTRONICS PRODUCTS, OR ANY SYSTEMS CREATED USING RENESAS ELECTRONICS PRODUCTS WILL BE INVULNERABLE OR FREE FROM CORRUPTION, ATTACK, VIRUSES, INTERFERENCE, HACKING, DATA LOSS OR THEFT, OR OTHER SECURITY INTRUSION ("Vulnerability Issues"). RENESAS ELECTRONICS DISCLAIMS ANY AND ALL RESPONSIBILITY OR LIABILITY ARISING FROM OR RELATED TO ANY VULNERABILITY ISSUES. FURTHERMORE, TO THE EXTENT PERMITTED BY APPLICABLE LAW, RENESAS ELECTRONICS DISCLAIMS ANY AND ALL WARRANTIES, EXPRESS OR IMPLIED, WITH RESPECT TO THIS DOCUMENT AND ANY RELATED OR ACCOMPANYING SOFTWARE OR HARDWARE, INCLUDING BUT NOT LIMITED TO THE IMPLIED WARRANTIES OF MERCHANTABILITY, OR FITNESS FOR A PARTICULAR PURPOSE.
8. When using Renesas Electronics products, refer to the latest product information (data sheets, user's manuals, application notes, "General Notes for Handling and Using Semiconductor Devices" in the reliability handbook, etc.), and ensure that usage conditions are within the ranges specified by Renesas Electronics with respect to maximum ratings, operating power supply voltage range, heat dissipation characteristics, installation, etc. Renesas Electronics disclaims any and all liability for any malfunctions, failure or accident arising out of the use of Renesas Electronics products outside of such specified ranges.
9. Although Renesas Electronics endeavors to improve the quality and reliability of Renesas Electronics products, semiconductor products have specific characteristics, such as the occurrence of failure at a certain rate and malfunctions under certain use conditions. Unless designated as a high reliability product or a product for harsh environments in a Renesas Electronics data sheet or other Renesas Electronics document, Renesas Electronics products are not subject to radiation resistance design. You are responsible for implementing safety measures to guard against the possibility of bodily injury, injury or damage caused by fire, and/or danger to the public in the event of a failure or malfunction of Renesas Electronics products, such as safety design for hardware and software, including but not limited to redundancy, fire control and malfunction prevention, appropriate treatment for aging degradation or any other appropriate measures. Because the evaluation of microcomputer software alone is very difficult and impractical, you are responsible for evaluating the safety of the final products or systems manufactured by you.
10. Please contact a Renesas Electronics sales office for details as to environmental matters such as the environmental compatibility of each Renesas Electronics product. You are responsible for carefully and sufficiently investigating applicable laws and regulations that regulate the inclusion or use of controlled substances, including without limitation, the EU RoHS Directive, and using Renesas Electronics products in compliance with all these applicable laws and regulations. Renesas Electronics disclaims any and all liability for damages or losses occurring as a result of your noncompliance with applicable laws and regulations.
11. Renesas Electronics products and technologies shall not be used for or incorporated into any products or systems whose manufacture, use, or sale is prohibited under any applicable domestic or foreign laws or regulations. You shall comply with any applicable export control laws and regulations promulgated and administered by the governments of any countries asserting jurisdiction over the parties or transactions.
12. It is the responsibility of the buyer or distributor of Renesas Electronics products, or any other party who distributes, disposes of, or otherwise sells or transfers the product to a third party, to notify such third party in advance of the contents and conditions set forth in this document.
13. This document shall not be reprinted, reproduced or duplicated in any form, in whole or in part, without prior written consent of Renesas Electronics.
14. Please contact a Renesas Electronics sales office if you have any questions regarding the information contained in this document or Renesas Electronics products.

(Note1) "Renesas Electronics" as used in this document means Renesas Electronics Corporation and also includes its directly or indirectly controlled subsidiaries.

(Note2) "Renesas Electronics product(s)" means any product developed or manufactured by or for Renesas Electronics.

(Rev.5.0-1 October 2020)

## Corporate Headquarters

TOYOSU FORESIA, 3-2-24 Toyosu,  
Koto-ku, Tokyo 135-0061, Japan  
[www.renesas.com](http://www.renesas.com)

## Trademarks

Renesas and the Renesas logo are trademarks of Renesas Electronics Corporation. All trademarks and registered trademarks are the property of their respective owners.

## Contact Information

For further information on a product, technology, the most up-to-date version of a document, or your nearest sales office, please visit:  
[www.renesas.com/contact/](http://www.renesas.com/contact/)