

IAR.T SERIES CURRENT CONTROL RELAY

UL listed CSA recognized



- **Automatic or Manual Control**
- **Start-up Inhibit**
- **Adjustable Hysteresis**
- **Multiple Voltages**
- **5 to 100 Amp RMS**

The DIAR.T is a current control which is capable of sensing up to 100 Amps. It requires a stepdown transformer, T1 100. The transformer has a 0.4" diameter center hole through which a current carrying lead is routed. Automatic or manual unlatching is available in each unit.

1. AC Current Control Without Latching:

The output relay is energized when the AC current overshoots the level selected on the potentiometer. It de-energizes when the current falls below the selected current by 5 to 50% or when input power breaks. The hysteresis is controlled by a top mounted potentiometer and its selection does not change the chosen current level.

2. AC Current Control With Latching:

The output relay is energized when the current reaches the selected value and stays latched. The contact between terminal B1 and B2 (or 11 and 9) should be opened or input power to the device interrupted to reset. In this case, it is preferable to reduce the hysteresis 5%.

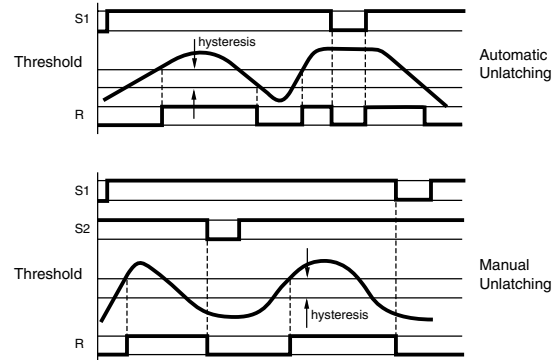

SPECIFICATIONS:

Input	24 VDC, 24, 48, 110, 220 VAC	
	±15%, 50/60 Hz	
Power consumption	3 VA maximum	
Hysteresis selection	5 to 50% of input current	
Repeat accuracy	±2% at a constant ambient	
	±5% with temperature variation	
	VDE 0435	
Response time	100 ms On Make	
	200 ms On Break	
Output Relay	SPDT Relay	
Contact material	AgCdO	
Maximum loading	10 AAC resistive	1 A DC inductive
Maximum switching voltage	250 VAC	30 VDC
Relay maximum power rating	2500 VA	30 W
Mechanical life of relay	30 x 10 ⁴ operations	
Electrical life of relay	2 x 10 ⁵ at 2500 VA resistive load	
Operating temperature	+14°F to +140°F	-10°C to +60°C
Weight	7 oz. (200g)	

WIRING DIAGRAM:

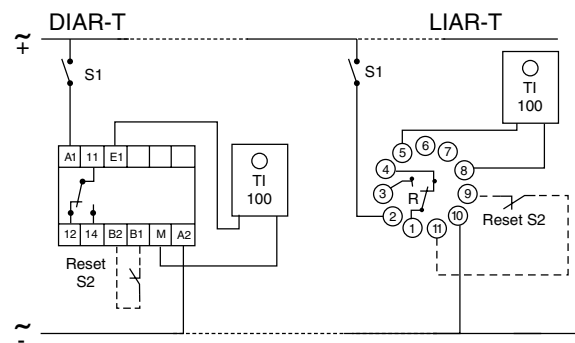

Note: Upon energization of the current control IAR.T Series Relay, the time delay, which is adjustable from .1 to 10 seconds, inhibits the output relay during start-up periods. The delay time is adjustable via a potentiometer located on the side of the case. For additional current transformer see "Accessories" section: L595 Series.

TRANSFORMER: (Part Number 74 525 305)

Current Range: 5 to 100 A RMS

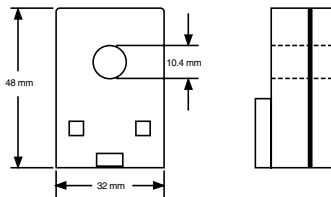

Maximum Overload: 1 max = 150 A

ORDERING INFORMATION:

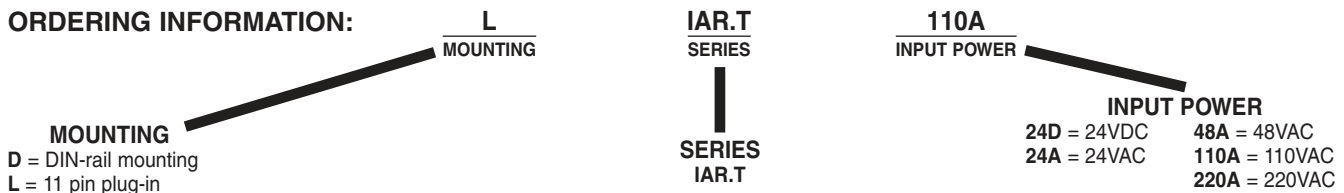

Products and specifications subject to change without notice.
Consult factory for application assistance.

DIMENSIONS:

D - DIN-Rail

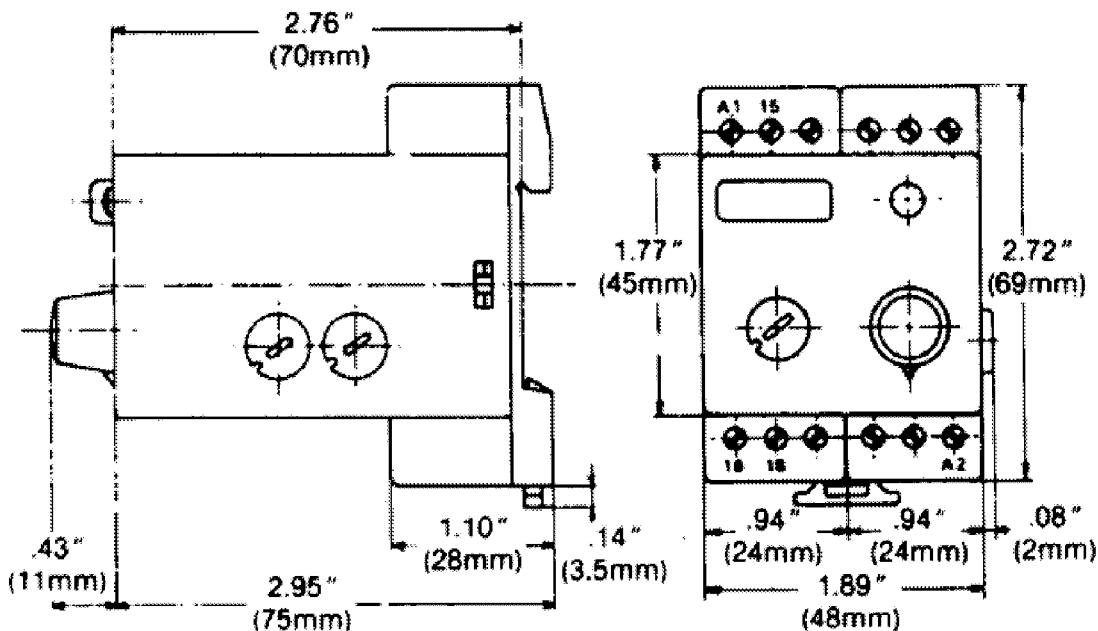

L & P - Sockets

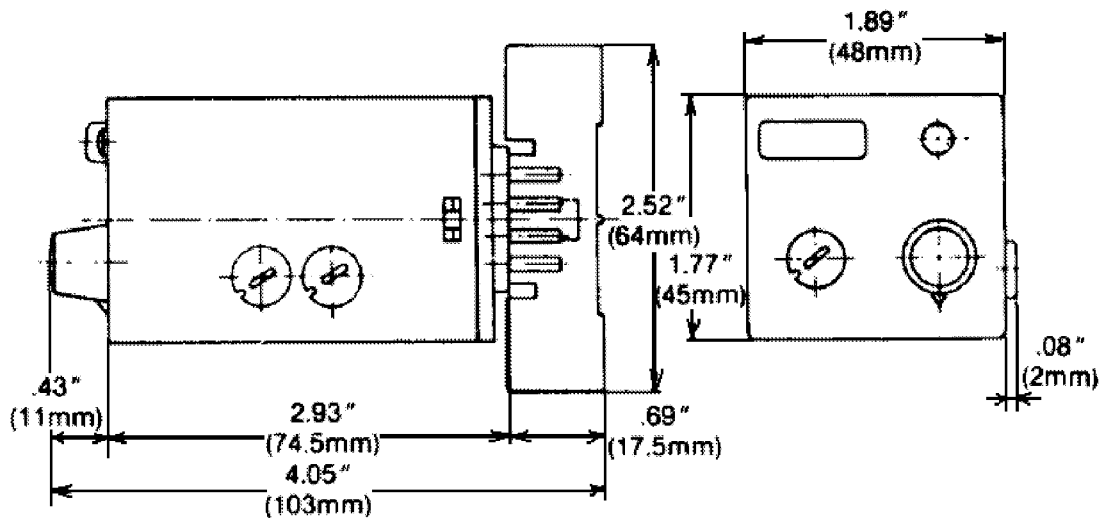

Products and specifications subject to change without notice.
Consult factory for application assistance.