

521744-1 ✓ ACTIVE

FASTIN-FASTON | FASTIN-FASTON 250

TE Internal #: 521744-1

Crimp Terminal Housings, Tab, Tab Housing, 1 Position, Straight,
UL 94V-2, Natural, Nylon, Contact Mating Retention, FASTIN-
FASTON 250

[View on TE.com >](#)



Terminals & Splices > Terminal Housings, Insulation Sleeves & Blocks > Crimp Terminal Housings



Terminal Type: **Tab**

Connector & Housing Type: **Tab Housing**

Number of Positions: **1**

Terminal Orientation: **Straight**

UL Flammability Rating: **UL 94V-2**

Features

Product Type Features

Sealable	No
Connector & Housing Type	Tab Housing

Configuration Features

Number of Positions	1
---------------------	---

Body Features

Primary Product Color	Natural
-----------------------	---------

Contact Features

Terminal Type	Tab
Terminal Orientation	Straight
Contact Mating Retention	With

Mechanical Attachment

Mating Alignment	With
Connector Mounting Type	Cable Mount (Free-Hanging)



Housing Features

Housing Material	Nylon
------------------	-------

Usage Conditions

Operating Temperature Range	-40 – 105 °C[-40 – 221 °F]
-----------------------------	----------------------------

Industry Standards

UL Flammability Rating	UL 94V-2
------------------------	----------

Packaging Features

Packaging Method	Carton
------------------	--------

Product Compliance

[For compliance documentation, visit the product page on TE.com>](#)

EU RoHS Directive 2011/65/EU	Compliant
EU ELV Directive 2000/53/EC	Compliant
China RoHS 2 Directive MIIT Order No 32, 2016	No Restricted Materials Above Threshold
EU REACH Regulation (EC) No. 1907/2006	Current ECHA Candidate List: JUNE 2023 (235) Candidate List Declared Against: JAN 2023 (233) Does not contain REACH SVHC
Halogen Content	Low Halogen - Br, Cl, F, I < 900 ppm per homogenous material. Also BFR/CFR/PVC Free
Solder Process Capability	Not applicable for solder process capability

Product Compliance Disclaimer

This information is provided based on reasonable inquiry of our suppliers and represents our current actual knowledge based on the information they provided. This information is subject to change. The part numbers that TE has identified as EU RoHS compliant have a maximum concentration of 0.1% by weight in homogenous materials for lead, hexavalent chromium, mercury, PBB, PBDE, DBP, BBP, DEHP, DIBP, and 0.01% for cadmium, or qualify for an exemption to these limits as defined in the Annexes of Directive 2011/65/EU (RoHS2). Finished electrical and electronic equipment products will be CE marked as required by Directive 2011/65/EU. Components may not be CE marked. Additionally, the part numbers that TE has identified as EU ELV compliant have a maximum concentration of 0.1% by weight in homogenous materials for lead, hexavalent chromium, and mercury, and 0.01% for cadmium, or qualify for an exemption to these limits as defined in the Annexes of Directive 2000/53/EC (ELV). Regarding the REACH Regulation, the information TE provides on SVHC in articles for this part number is based on the latest European Chemicals Agency (ECHA) 'Guidance on requirements for substances in articles' posted at this URL: <https://echa.europa.eu/guidance-documents/guidance-on-reach>

Compatible Parts



TE Part # 180906
FF 250 TAB HSG 6P NYLON NAT



TE Part # 626063
1 WAY FASTIN-ON 110 HSG TAB NAT NYLON



TE Part # 180916
FF 250 TAB HSG 1P NYLON NAT



TE Part # 480053-3
FF 250 TAB HSG 1P NYLON NAT



TE Part # 172127-1
FF 250 PLUG HSG 1P NYLON NAT



TE Part # 2-180916-0
FF 250 TAB HSG 1P NYLON NAT



TE Part # 480053-4
FF 250 TAB HSG 1P NYLON BLACK



TE Part # 1-480282-0
FF 250 TAB HSG 6P NYLON BLACK



TE Part # 480053-5
FF 250 TAB HSG 1P NYLON RED



TE Part # 1-480251-0
FF 187 TAB HSG 3P NYLON NAT

Also in the Series | **FASTIN-FASTON 250**

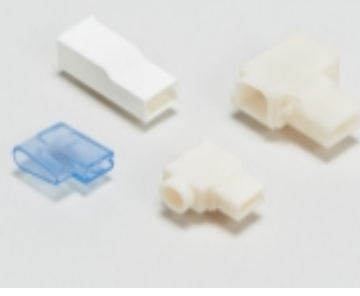

Crimp Terminal Housings(211)



Insertion & Extraction Tools(2)



PCB Terminals(2)



Quick Disconnects(254)

Customers Also Bought



TE Part #282080-3
AMP SUPERSEAL 1.5MM,
CONNECTOR HOUSING



TE Part #965082-1
2X 2P LOCK-CLIP GEH



TE Part #42460-1
FF 250 TAB 18-14AWG BR



TE Part #5-867052-1
LOCKING CLIP CONT ASSY .025 SQ



TE Part #282764-1
JPT SPLASH-PROOF FEM.CONN4
POS



TE Part #31890
PIDG R 22-16 COMM 22-18 MIL 8



TE Part #1718348-3
MCON 1.2 CB TAB STC AG

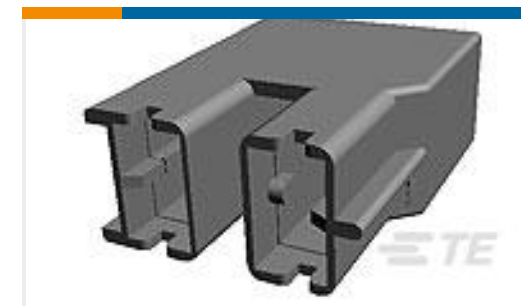

TE Part #926521-2
PL 250 REC HSG 2P NYLON BLACK

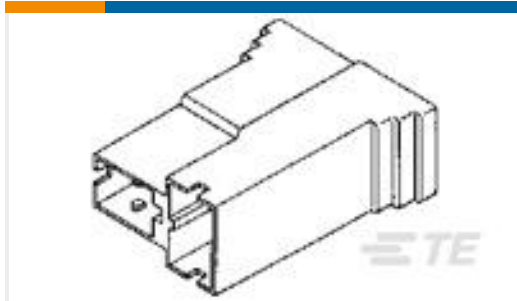

TE Part #926522-2
PL 250 REC HSG 2P NYLON NAT

Documents

Product Drawings

[FASTIN FASTON 250 HOUSING TAB NYLON 6/6](#)

English

CAD Files

Customer View Model

[ENG_CVM_CVM_521744-1_B.2d_dxf.zip](#)

English

3D PDF

3D

Customer View Model

[ENG_CVM_CVM_521744-1_B.3d_igs.zip](#)

English

Customer View Model

[ENG_CVM_CVM_521744-1_B.3d_stp.zip](#)

English

By downloading the CAD file I accept and agree to the [Terms and Conditions](#) of use.

Datasheets & Catalog Pages

[FASTIN_FASTON_Product_Line](#)

English

[White Paper: Nylon Discoloration](#)

English

Product Specifications

[Application Specification](#)

English

521744-1

Crimp Terminal Housings, Tab, Tab Housing, 1 Position, Straight, UL 94V-2, Natural, Nylon, Contact Mating Retention, FASTIN-FASTON 250

