

PRODUCT NO.
10150098-3200RLF

PCB LAYOUT PROPOSAL

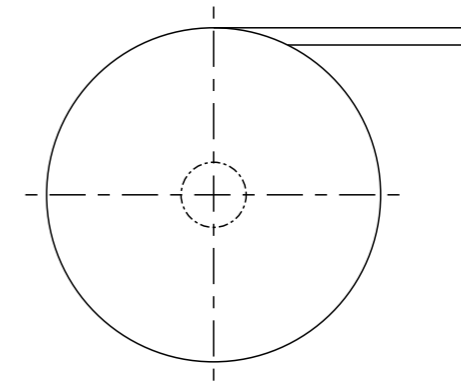
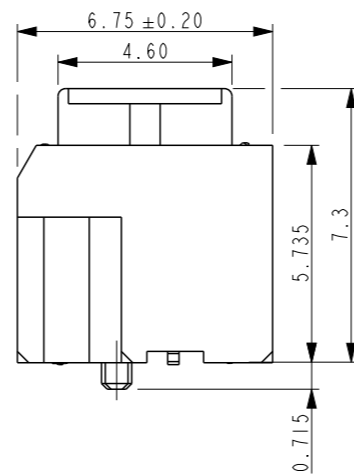
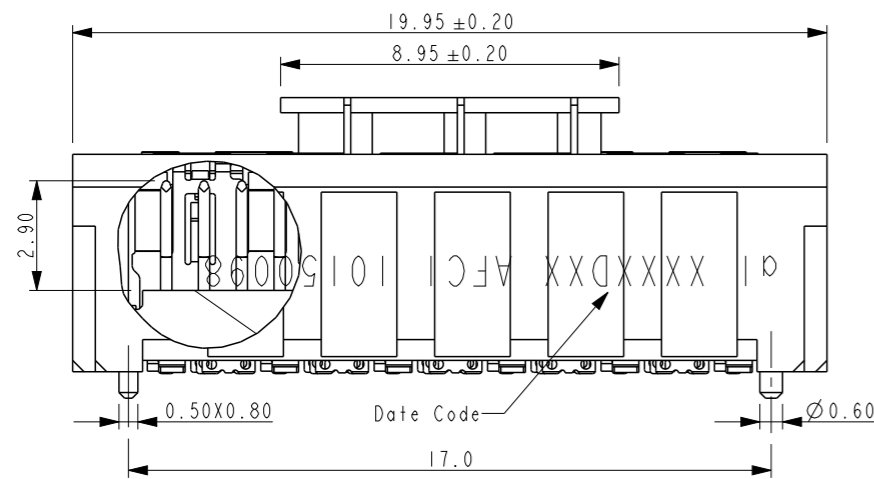
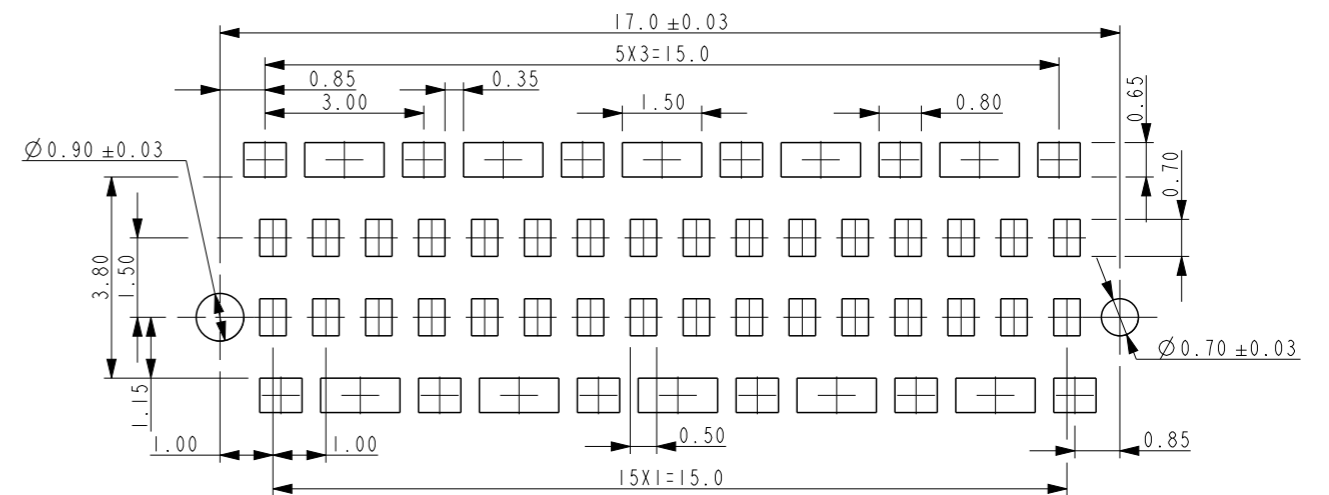
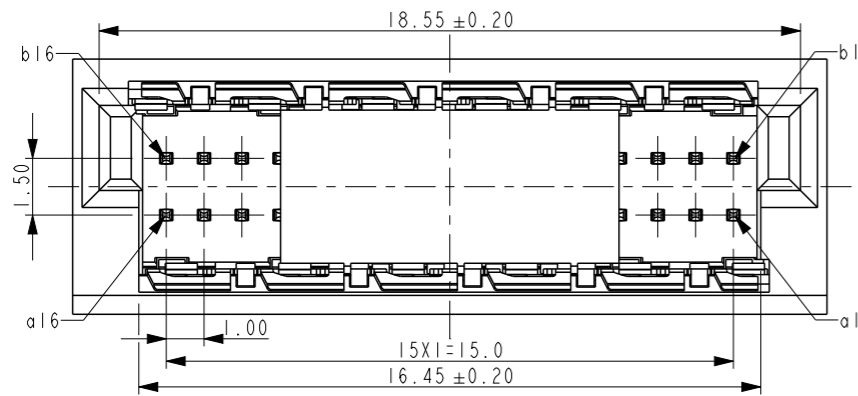

Package Description:
1. External diameter of Reel: Ø330
2. Leader 400mm/ Trailer 160mm
3. Packaging unit: 400 pcs/Reel

Reel off direction
→

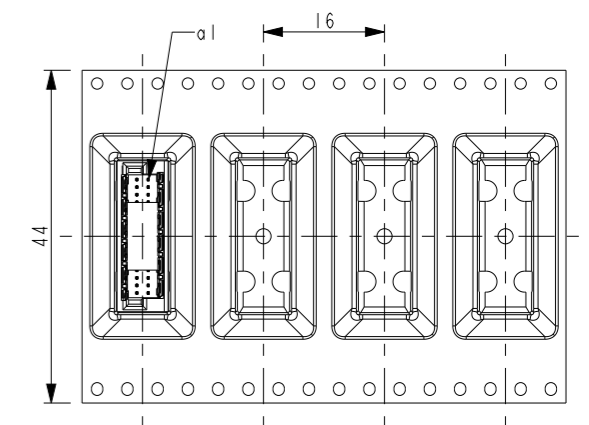

Note

1. Material:
 - 1.1 Housing and Cap: LCP 30%GF, E1301 Black, Ticona
 - 2.2 Terminal and shield: CuSn6
 2. Plating: 1-3µm Ni under plating, 2-4µm Sn on solder area, 0.65 µm PdNi, 0.10µm Au on mating area.
 3. Coplanarity area of Termination 0.10mm Max (/1)

(/1) Inspection level 1: control chart required
Proof of process capability or 100% test if process capability is not achieved

(/2) Inspection level 2 and 3: control chart required
Proof of mean value, standard deviation and machine capability

(/3) Proof of values or proof of attributive test

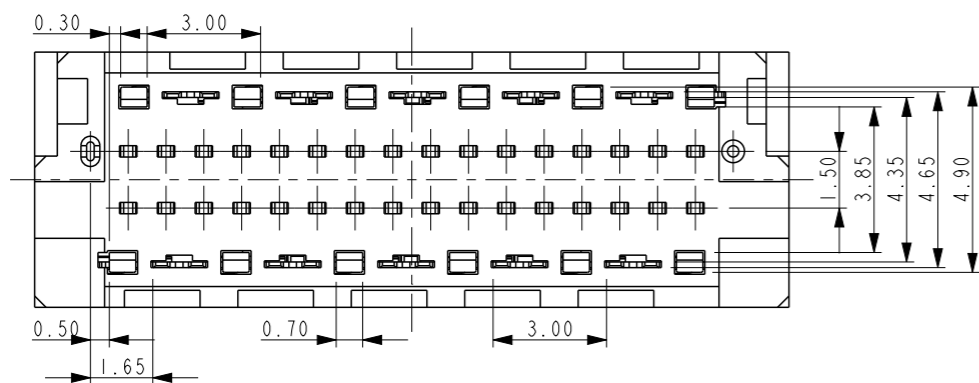

spec ref	*	dr	Li-Qing Lei	2018/11/26	projection	mm	size	A3	scale	5:1
tolerance std	TOLERANCES UNLESS OTHERWISE SPECIFIED	eng	Li-Qing Lei	2020/10/09			ecn no	ELX-N-38561-1	rel level	Released
		chr	-	-						
surface	linear	appr	Tim Yao	2020/10/09	Male 2mm SMD 32 pos		dwg no	10150098	rev	B
ASME Y14.5	angular				Microspeed Vertical Series					
		cat. no.			Product - Customer Drw			sheet 1 of 1		