

618 Series, 5×20 mm, Time-Lag Fuse



Description

5×20mm Time-Lag glass body cartridge fuse designed to IEC specification.





Features

- Designed to International (IEC) Standards for use globally
- Meets the IEC 60127-2, Sheet 3 specification for Time-Lag fuses
- Available in cartridge and axial lead form
- RoHS compliant and lead-free

Applications

Used as supplementary protection in appliance or utilization equipment to provide individual protection for components or internal circuits.

Agency Approvals

Agency	Agency File Number	Ampere Range
	2005010207170553	0.125A-6.3A
	E10480	0.125A-10A
	29862	0.125A-10A
	40013496	0.125A – 10A
	N/A	0.125A-10A

* Approval for Cartridge versions only

Additional Information



[Datasheet](#)



[Resources](#)



[Samples](#)

Electrical Characteristics

% of Ampere Rating	Ampere Rating	Opening Time
150%	0.125A-6.3A	60 minutes, Minimum
	8A-10A	30 minutes, Minimum
210%	0.125A-6.3A	120 sec., Maximum
	8A-10A	120 sec., Maximum
275%	0.125A-6.3A	600 ms., Min.; 10 sec. Max.
	8A-10A	600 ms., Min.; 10 sec. Max.
400%	0.125A-6.3A	150 ms., Min.; 3 sec. Max.
	8A-10A	150 ms., Min.; 3 sec. Max.
1000%	0.125A-6.3A	20 ms., Min.; 300 ms. Max.
	8A-10A	20 ms., Min.; 300 ms. Max.

Axial Lead & Cartridge Fuses

5x20 mm > Time-Lag > 618 Series

Electrical Characteristics

Amp Code	Amp Rating (A)	Voltage Rating (V)	Interrupting Rating	Nominal Cold Resistance (Ohms)	Nominal Melting I ² t (A ² sec)	Maximum Voltage Drop at Rated Current (mV)	Maximum Power Dissipation At 1.5In(W)	Agency Approvals					
								CCC	RU	SF	CE	DE	
.125	0.125	250	35 A @ 250 VAC	4.2000	0.1465	1900	1.6	x	x	x	x	x	
.160	0.16	250		3.7000	0.14400	1500	1.6	x	x	x	x	x	
.200	0.2	250		1.6000	0.3410	1300	1.6	x	x	x	x	x	
.250	0.25	250		1.0495	0.5405	1100	1.6	x	x	x	x	x	
.315	0.315	250		0.8475	1.1100	1000	1.6	x	x	x	x	x	
.400	0.4	250		0.5350	1.3250	900	1.6	x	x	x	x	x	
.500	0.5	250		0.3700	2.8250	300	1.6	x	x	x	x	x	
.630	0.63	250		0.2750	4.6750	250	1.6	x	x	x	x	x	
.800	0.8	250		0.0813	3.370	150	1.6	x	x	x	x	x	
.001	1	250		0.0613	6.730	150	1.6	x	x	x	x	x	
1.25	1.25	250		0.0446	12.650	150	1.6	x	x	x	x	x	
01.6	1.6	250		0.0336	23.350	150	1.6	x	x	x	x	x	
002.	2	250		0.0293	14.450	150	1.6	x	x	x	x	x	
02.5	2.5	250		0.0219	23.250	120	1.6	x	x	x	x	x	
3.15	3.15	250		0.0173	38.150	100	1.6	x	x	x	x	x	
004.	4	250		40 A @ 250 VAC	0.0129	69.10	100	1.6	x	x	x	x	x
005.	5	250		50 A @ 250 VAC	0.0104	111.00	100	1.6	x	x	x	x	x
06.3	6.3	250	63 A @ 250 VAC	0.0076	198.50	100	1.6	x	x	x	x	x	
008.	8	250	80 A @ 250 VAC	0.0059	341.50	100	4		x	x	x	x	
010.	10	250	100 A @ 250 VAC	0.0045	568.00	100	4		x	x	x	x	

Temperature Re-rating Curve

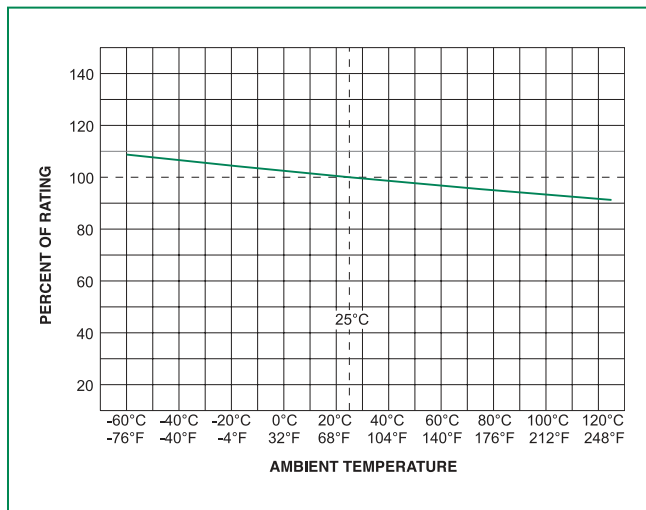

Note:
Rerating depicted in this curve is in addition to the standard derating of 25% for continuous operation.

Average Time Current Curves

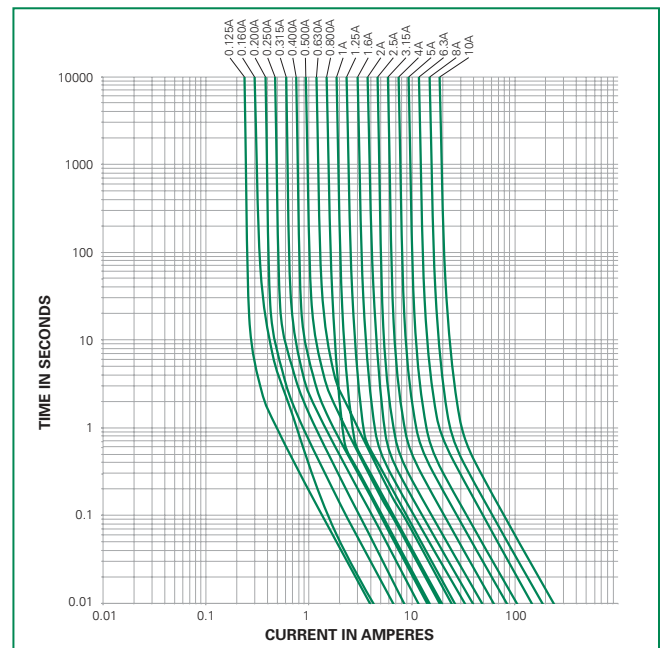

Soldering Parameters - Wave Soldering

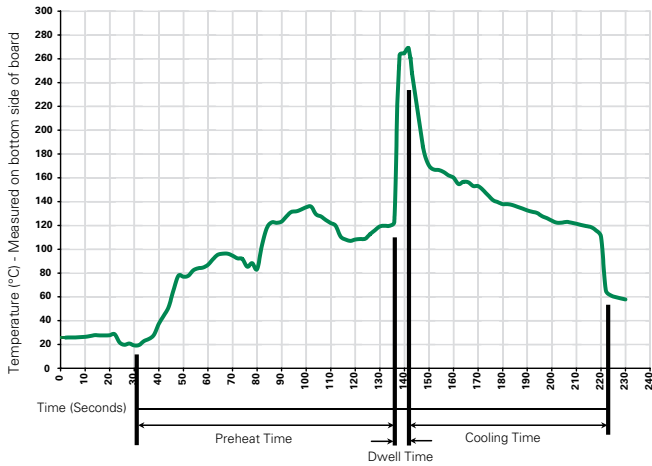

Recommended Process Parameters:

Wave Parameter	Lead-Free Recommendation
Preheat: (Depends on Flux Activation Temperature)	(Typical Industry Recommendation)
Temperature Minimum:	100°C
Temperature Maximum:	150°C
Preheat Time:	60-180 seconds
Solder Pot Temperature:	260°C Maximum
Solder Dwell Time:	2-5 seconds

Recommended Hand-Solder Parameters:

Solder Iron Temperature: 350°C +/- 5°C
 Heating Time: 5 seconds max.

Note: These devices are not recommended for IR or Convection Reflow process.

Product Characteristics

Material	Body: Glass Cap: Nickel-plated Brass Leads: Tin-plated Copper
Terminal Strength	MIL-STD-202, Method 211, Test Condition A
Solderability	MIL-STD-202 method 208
Product Marking	Cap1: Brand logo, current and voltage ratings Cap2: Agency approval marks
Packaging	Available in Bulk (M=1000 pcs/pkg) or on Tape/Reel (MRET1=1000 pcs/reel)

Operating Temperature	-55°C to +125°C
Thermal Shock	MIL-STD-202, Method 107, Test Condition B (5 cycles, -65°C to +125°C)
Vibration	MIL-STD-202, Method 201
Humidity	MIL-STD-202, Method 103, Test Condition A (High RH (95%) and elevated temperature (40°C) for 240 hours)
Salt Spray	MIL-STD-202, Method 101, Test Condition B

Dimensions

0618 000P

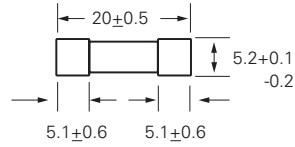

0618.125 XEP
to
0618010. XEP

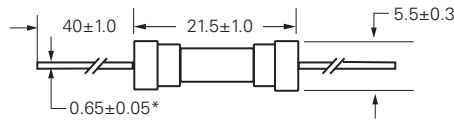

All dimensions in mm

Notes:

* Ratings above 6.3A have 0.8±0.05 diameter lead.

Part Numbering System

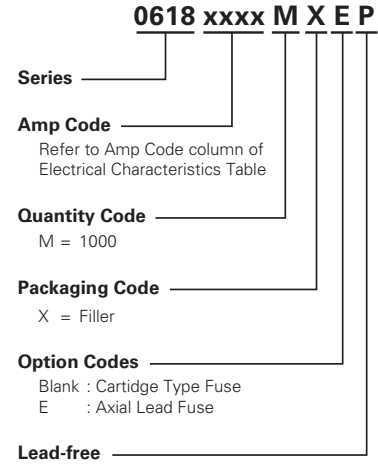

Packaging

Packaging Option	Packaging Specification	Quantity	Quantity & Packaging Code	Taping Width
618 Series				
Bulk	N/A	1000	MX	N/A
Bulk	N/A	1000	MXE	N/A
Reel and Tape	EIA 296-E	1000	MRET1	T1=53mm (2.087")
Bulk	N/A	1000	MXG	N/A
Bulk	N/A	1000	MXB	N/A
Bulk	N/A	100	HX	N/A