



Micro Metal DC Geared Motor (6V 50RPM 250g*cm)

SKU:FIT0579

INTRODUCTION

This motor has a long (0.365" or 9.27 mm), D-shaped metal output shaft that matches the Pololu wheel 42x19mm and 32x7mm. The brass faceplate has two mounting holes threaded for M1.6 screws (1.6 mm diameter, 0.35 mm thread pitch), or you can use the mounting bracket or extended mounting bracket, which are specifically designed to securely mount the gearmotor while enclosing the exposed gears. We recommend the extended mounting bracket for wheels with recessed hubs, such as the wheel 42x19 mm.

This motor is suitable to be used in the mini mobile platform. As the 2 wheels miniQ platform, it can directly work with the MiniQ Robot chassis Encoder, mounting bracket and directly compatible with wheels.

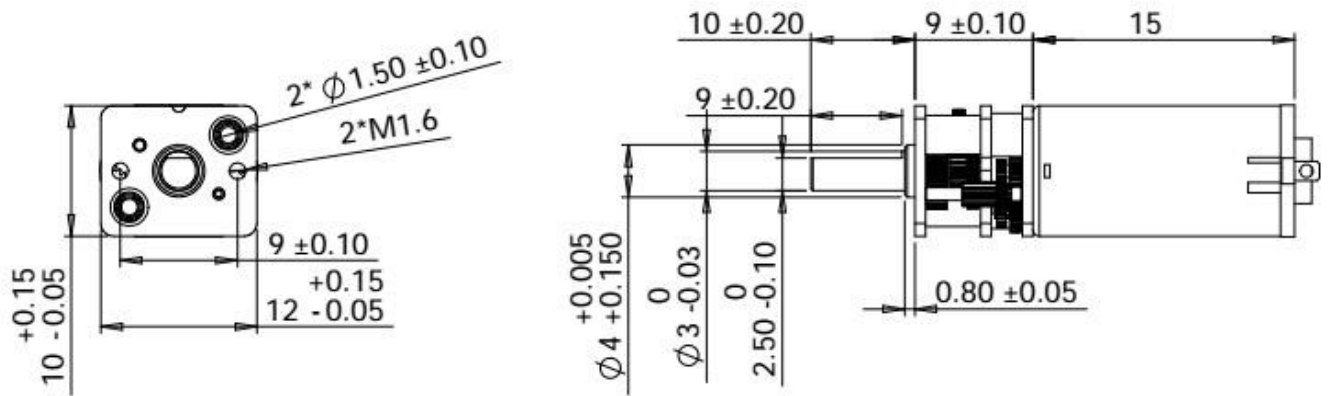

SPECIFICATION

- Reduction ratio: 1:298
- Standard operating voltage: 6V
- No-load current: 24±10% mA (Max)
- No-load speed: 50±10% r/min
- Load current: 61±10% mA (Max)
- Load speed: 46±10% r/min
- Load: 250g*cm
- Stall current: 430 ± 10% mA (Max)
- Locking torque: 2200g*cm
- Single weight: about 10g
- Mechanical noise: ≤50dB (measured at about 10cm from the gearbox)

SHIPPING LIST

- Micro Metal DC Geared Motor with Lead Screw (6V 98RPM M3*20) x1