

"18650" LITHIUM-ION BATTERY HOLDERS

THM Leaf Springs

THM Polarized

Solder Lugs*

SMT Leaf Springs

SMT Polarized



1043

1049 (Dual Cell)
Not Shown

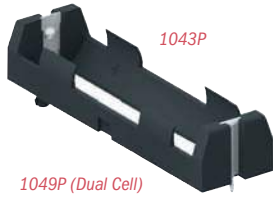

1043P

1049P (Dual Cell)
Not Shown



1044

1047 (Dual Cell)
Not Shown

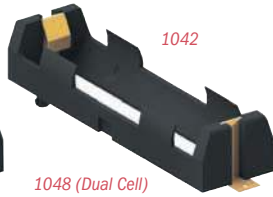

1042

1048 (Dual Cell)
Not Shown

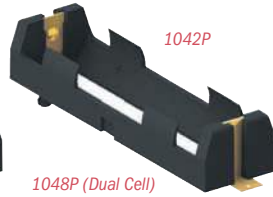

1042P

1048P (Dual Cell)
Not Shown

FEATURES

- Low profile surface mount holder for Cylindrical Lithium and alkaline batteries
- UL 94V-0 heat resistant nylon housing well suited for reflow soldering
- Battery installation and removal does not require tools
- Securely holds battery in place

- Accommodates cells with or without built-in PCB protection circuits
- Polarity clearly marked for orientation
- Polarized holders available for protection against improper battery installation

Operating Temp Range:
-60°F to +290°F (-50°C to +145°C)

APPLICATIONS

- Computer memory, power backup systems
- Digital readers
- Laptop and touch pad computers
- PLC and industrial controls
- Electronic cigarette/vapor industry



PC Battery Clip
Available
See Page 11.

THRU HOLE MOUNT

SURFACE MOUNT

SINGLE CELL

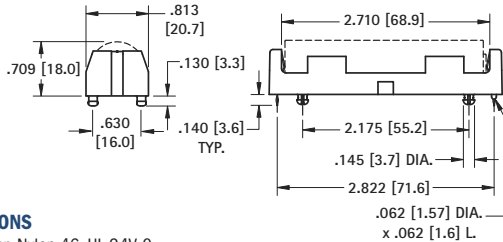

Mounting Detail

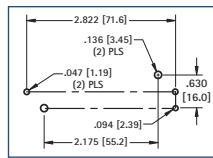

SPECIFICATIONS

Base: High Temp Nylon 46, UL 94V-0
Contacts: .012 (.30) Stainless Steel, Tin-Nickel Plate

CAT. NO. 1043 Leaf Springs

CAT. NO. 1043P Polarized Holder

CAT. NO. 1044 Solder Lugs *see image above

Packaging Spec's: 50 pieces per tray

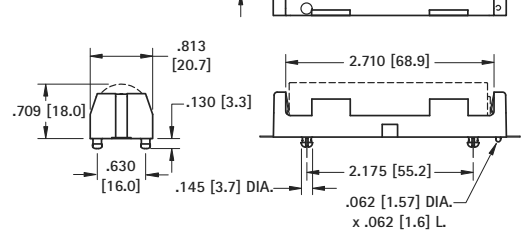

Pad Layout

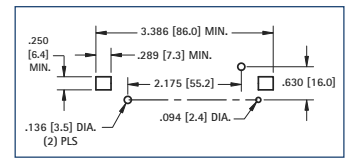

SPECIFICATIONS

Base: High Temp Nylon 46, UL 94V-0
Contacts: .012 (.30) Stainless Steel, Gold Plate (Flash)

CAT. NO. 1042 Leaf Springs

CAT. NO. 1042P Polarized Holder

Packaging Spec's: 50 pieces per tray

DUAL CELL

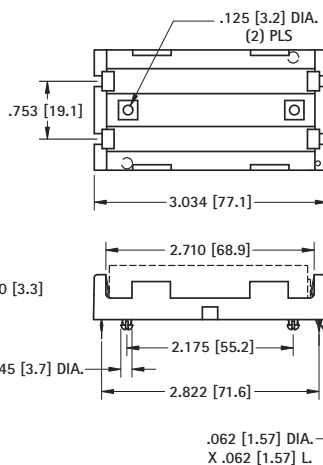

Mounting Detail

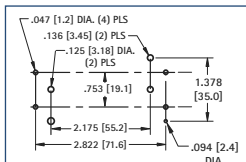

SPECIFICATIONS

Base: High Temp Nylon 46, UL 94V-0
Contacts: .012 (.30) Stainless Steel, Tin-Nickel Plate

CAT. NO. 1049 Dual Springs

CAT. NO. 1049P Polarized Holder

CAT. NO. 1047 Solder Lugs *see image above

Packaging Spec's: 25 pieces per tray

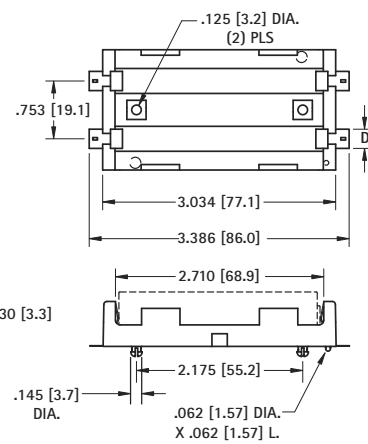

Pad Layout

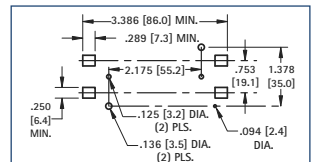

SPECIFICATIONS

Base: High Temp Nylon 46, UL 94V-0
Contacts: .012 (.30) Stainless Steel, Gold Plate (Flash)

CAT. NO. 1048 Dual Springs

CAT. NO. 1048P Polarized Holder

Packaging Spec's: 25 pieces per tray