

THIS DRAWING IS UNPUBLISHED. RELEASED FOR PUBLICATION
 © COPYRIGHT - By - ALL RIGHTS RESERVED.

LOC	DIST	REVISIONS			
P	LTR	DESCRIPTION	DATE	DWN	APVD
AF	50	K1	REVISED PER ECR-20-009164	3AUG2020	MK DH

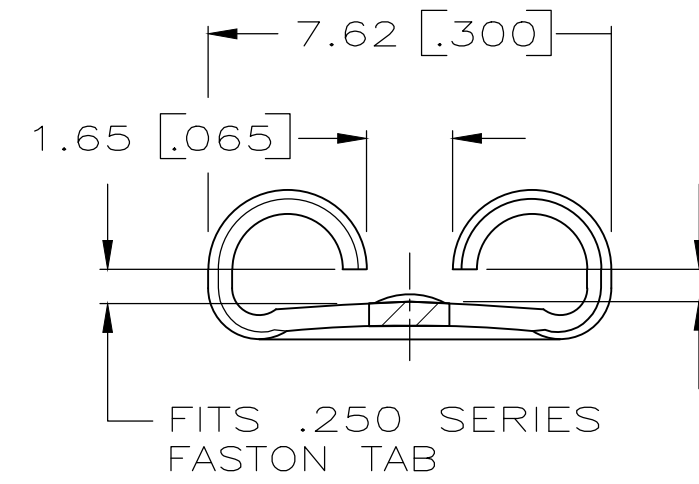
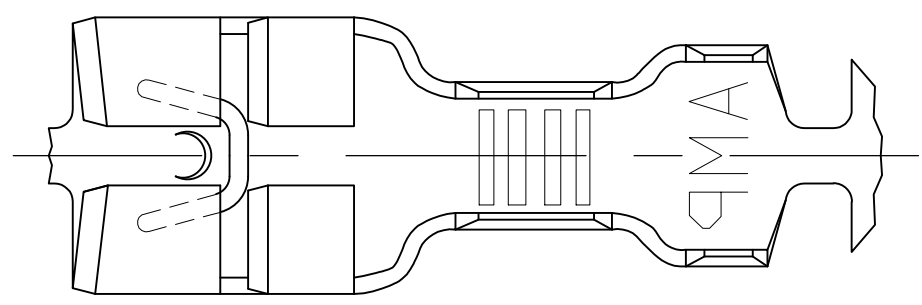

- 1 DIMENSIONS IN BRACKETS ARE IN INCHES.
- 2 CONTINUOUS STRIP ON REELS.

GAP AS REQUIRED TO MEET FORCE SPECIFICATIONS AND 0.71 [.028] MAX

VIEW A-A

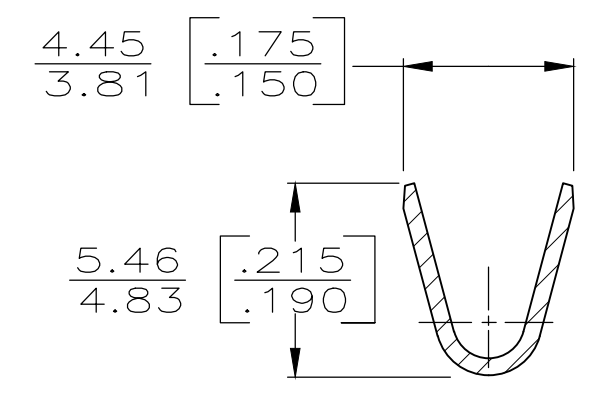
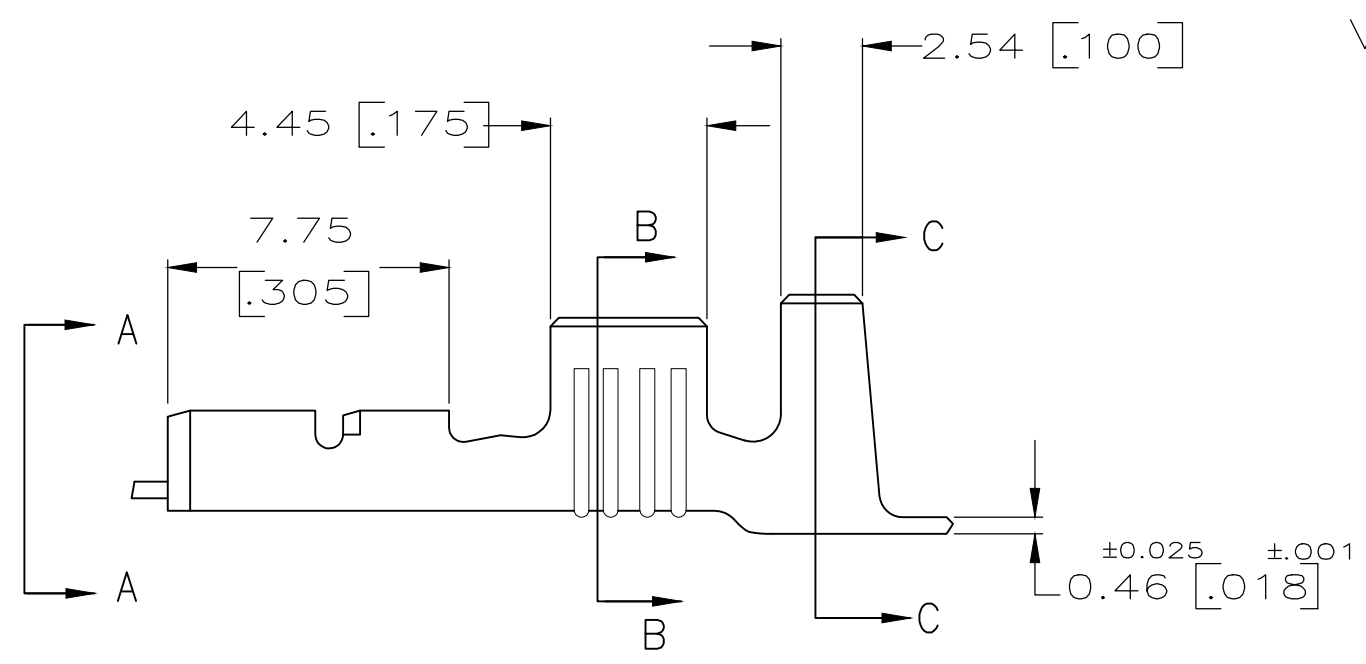

SECTION B-B

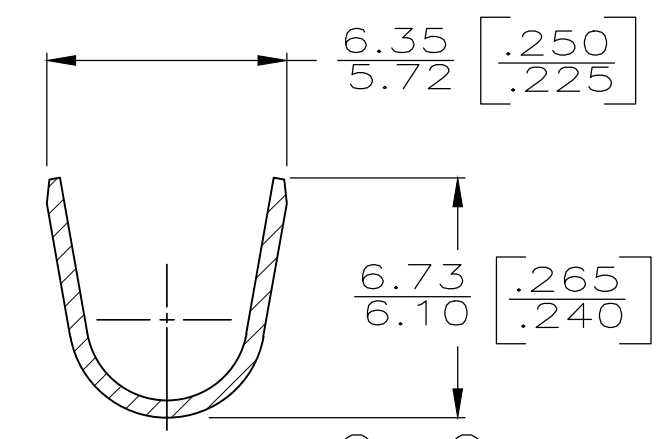

SECTION C-C

TIN	5.08-3.81 [.200-.150]	2.0-5.0mm ² [14-10]	0.84-0.76 [.033-.030]	63365-2
FINISH	INSULATION RANGE	WIRE SIZE	MATING TAB THK.	63365-1
				PART NO

THIS DRAWING IS A CONTROLLED DOCUMENT.		DWN JR RUTH 10/10/86	TE Connectivity RECEPTACLE, FASTON, LOW-INSERTION, .250 SERIES			
DIMENSIONS: mm [INCHES]		CHK M FEHER 12/1/87				NAME
TOLERANCES UNLESS OTHERWISE SPECIFIED:		APVD C MEYERS 12/1/87				PRODUCT SPEC
0 PLC ± - 1 PLC ± - 2 PLC ± - 3 PLC ± 0.25 [.010] 4 PLC ± - ANGLES ± -		APPLICATION SPEC				RESTRICTED TO
MATERIAL BRASS	FINISH -	WEIGHT -	SIZE A3	CAGE CODE 00779	DRAWING NO C-63365	
CUSTOMER DRAWING			SCALE 5:1	SHEET 1 OF 1	REV K1	