

LOC	DIST	REVISIONS					
GP	00	P	LTN	DESCRIPTION	DATE	DWN	APVD
		A		ECR-21-122345	22NOV22	TL	HL

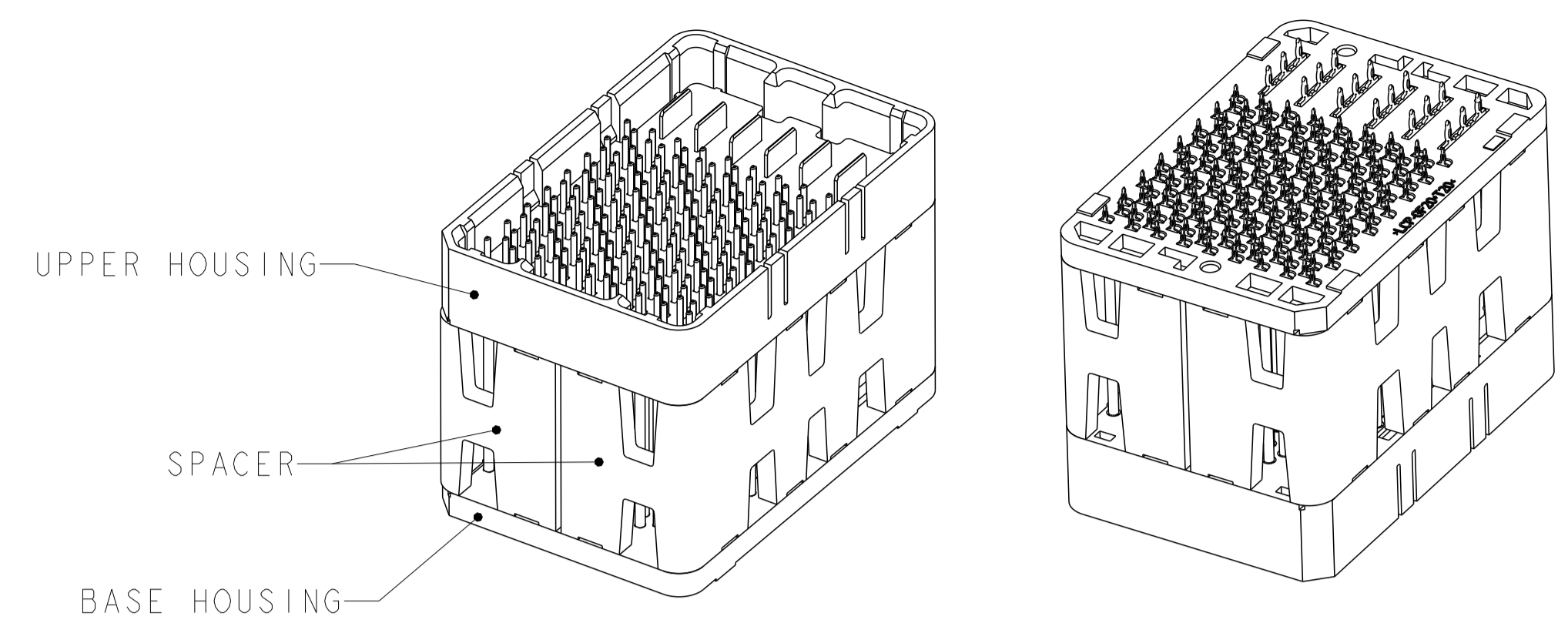

ISOMETRIC VIEW
TYPICAL CONFIGURATION FOR 14mm THRU 42mm
28mm SHOWN
SCALE 2:1

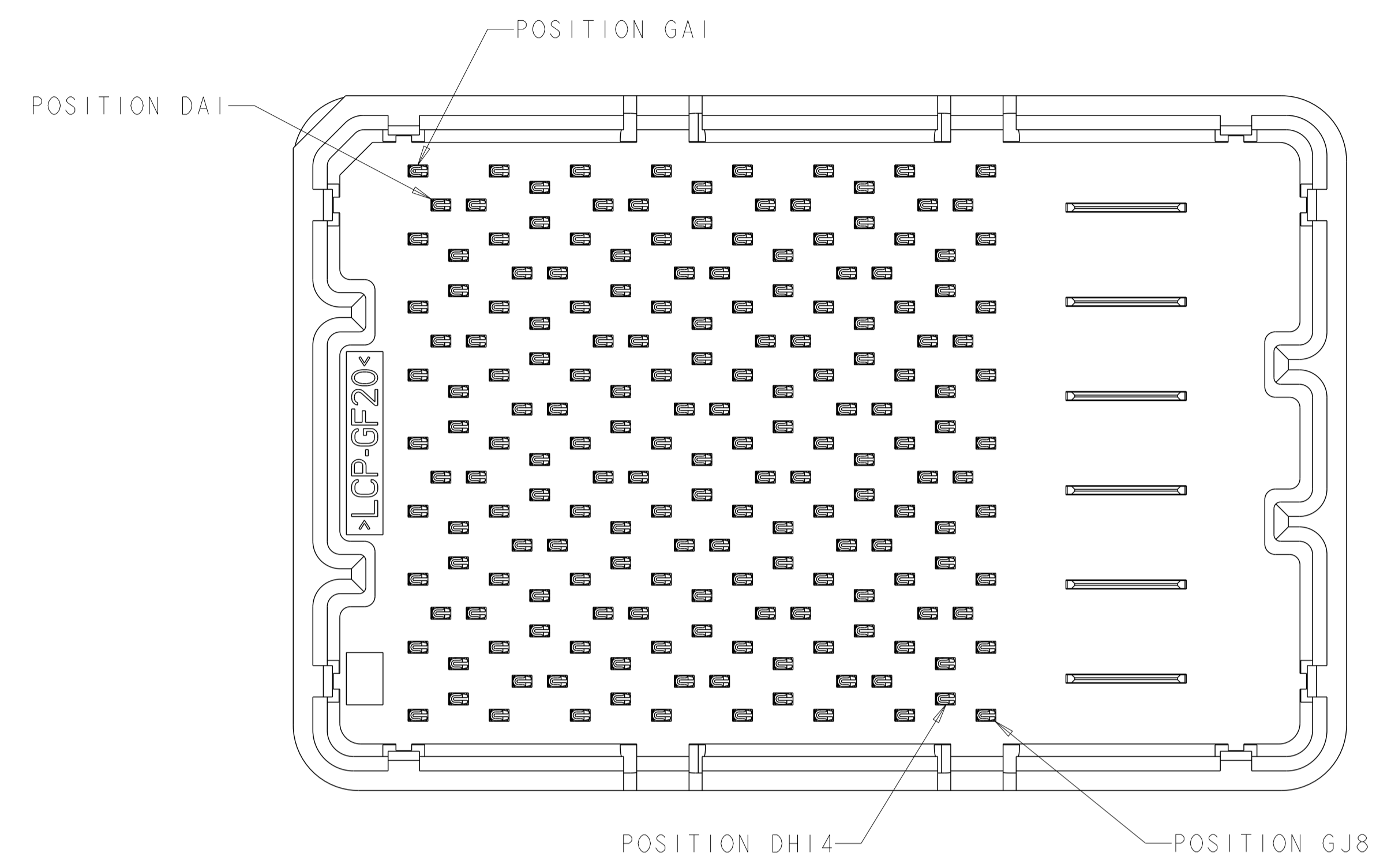
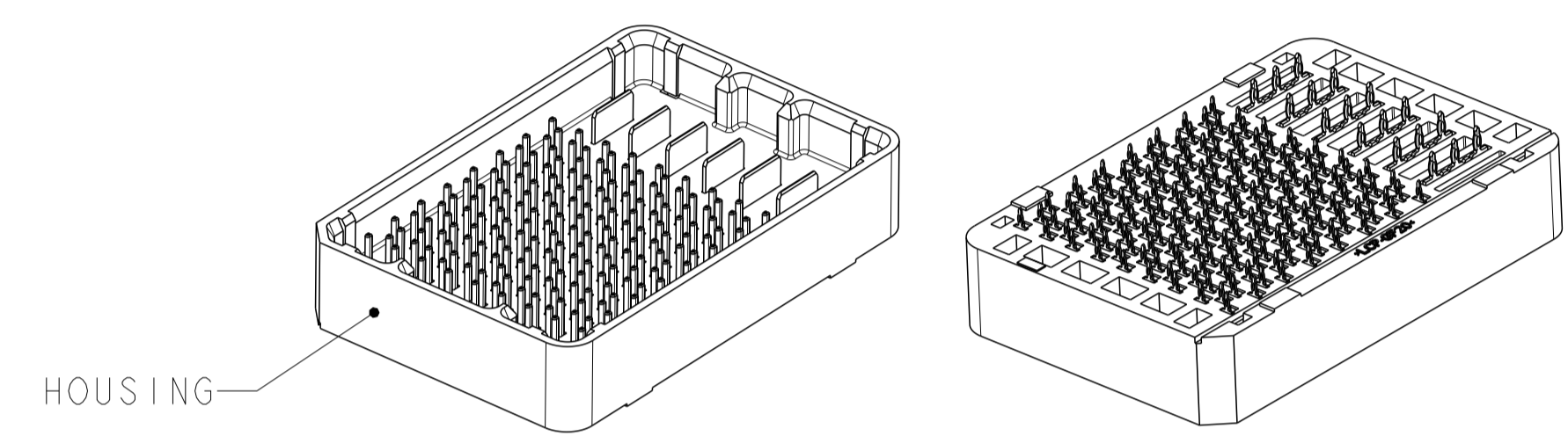

ISOMETRIC VIEW
TYPICAL CONFIGURATION FOR 8mm THRU 13mm
8mm SHOWN
SCALE 2:1

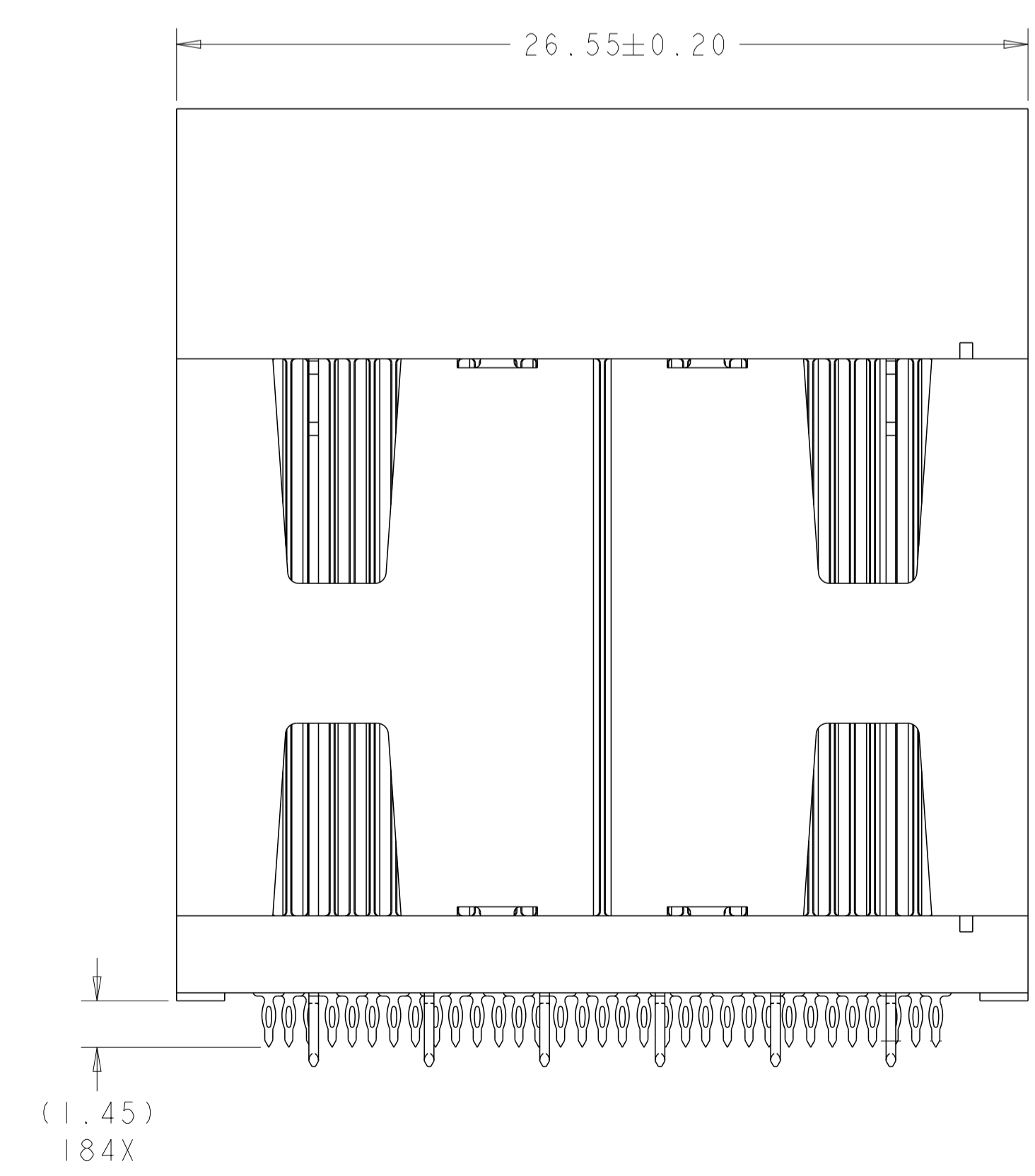
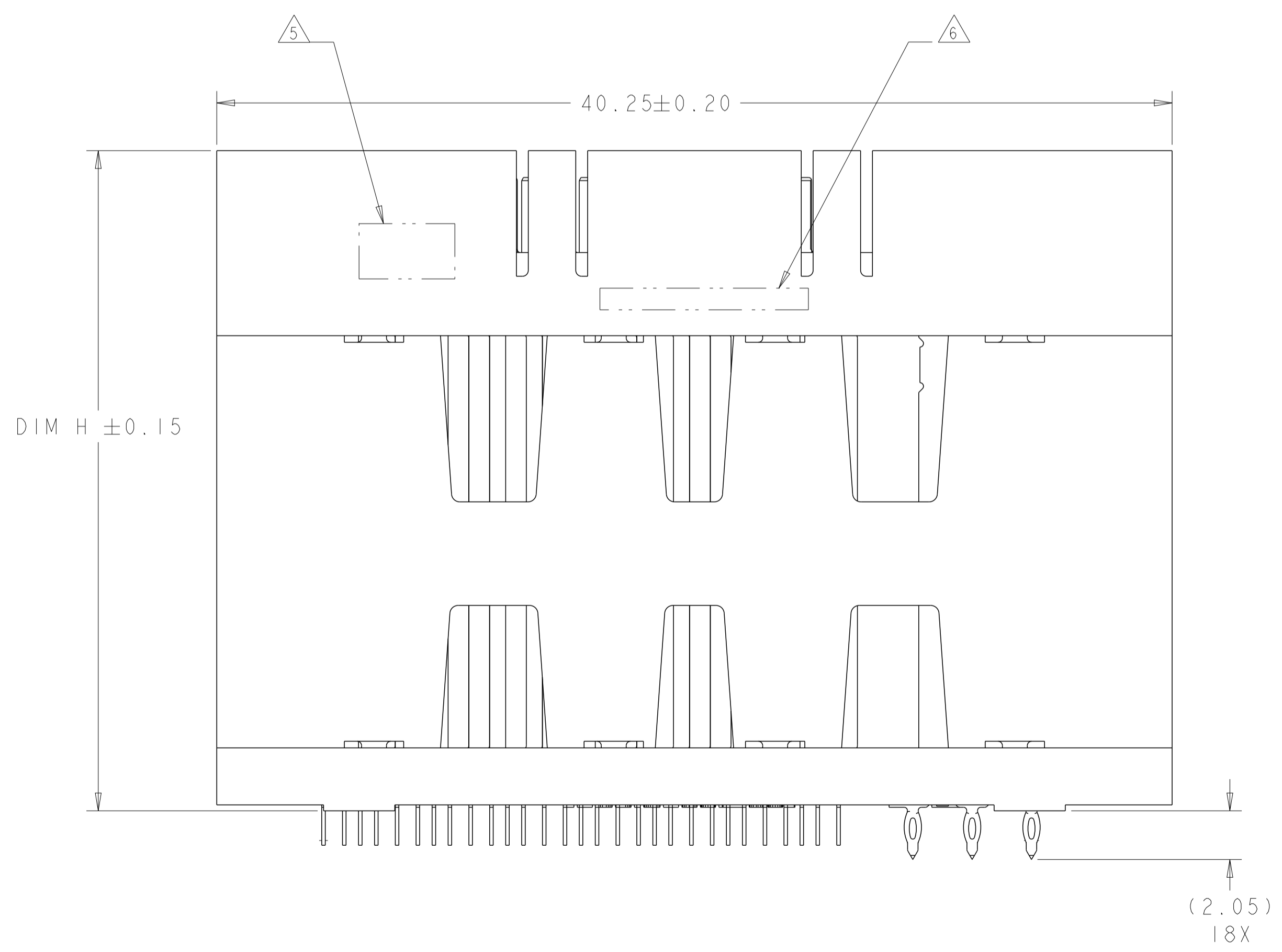

- 1. MATERIAL:
BASE HOUSING, UPPER HOUSING, ORGANIZER,
AND SPACER: THERMOPLASTIC, FLAMMABILITY
RATING UL94-V0
CONTACT: COPPER ALLOY
- 2. CONFORMS TO THE REQUIREMENTS OF TE PRODUCT
SPECIFICATION, 108-2375; BASED ON TELCORDIA
GR-1217-CORE FOR SYSTEM QUALITY LEVEL III,
APPLICATIONS IN CONTROLLED ENVIRONMENTS
(CENTRAL OFFICE).
SEE TE PRODUCT SPECIFICATION 108-2375 FOR
TEST SEQUENCES.
- 3. ROWS GA THRU GJ (SHOWN DARKENED) ARE TYPICALLY
USED AS GROUNDS.
- 4. SPECIFIED POSITIONAL TOLERANCE DEFINES HOLE TO
HOLE LOCATION WITHIN HOLE PATTERN. POSITIONAL
TOLERANCE OF HOLE PATTERN TO FIDUCIAL MARKS
OR PCB DATUMS SHALL BE DEFINED BY CUSTOMER.
- 5. AREA RESERVED FOR TE CONNECTIVITY LOGO.
- 6. AREA RESERVED FOR PART NUMBER (X-XXXXXX-X)
AND DATE CODE (YYWW).
- 7. USE CENTERLINES INDICATED ON PCB HOLE PATTERN
TO ESTABLISH ALIGNMENT BETWEEN HEADER AND
RECEPTACLE BOARDS.
- 8. PLATED THROUGH HOLE REQUIREMENTS - SIGNAL:
HOLE SIZE PRIOR TO PLATING = $\varnothing 0.420 \pm 0.013$
COPPER PLATING THICKNESS = 0.038 ± 0.013
CALCULATED FINISHED HOLE SIZE = $\varnothing 0.344 \pm 0.039$
THESE DIMENSIONS APPLY TO THE TOP 1.25mm OF
THE PCB THICKNESS FROM THE CONNECTOR MOUNTING
SIDE.
- 9. PLATED THROUGH HOLE REQUIREMENTS - POWER:
HOLE SIZE PRIOR TO PLATING = $\varnothing 0.700 \pm 0.025$
COPPER PLATING THICKNESS = 0.038 ± 0.013
CALCULATED FINISHED HOLE SIZE = $\varnothing 0.624 \pm 0.051$
THESE DIMENSIONS APPLY TO THE TOP 1.50mm OF
THE PCB THICKNESS FROM THE CONNECTOR MOUNTING
SIDE.
- 10. CONTACT SALES FOR AVAILABILITY OF THIS STACK
HEIGHT.

SIZE 2 HOUSING *
56 DIFFERENTIAL PAIRS
184 TOTAL SIGNAL CONTACTS
6 POWER CONTACTS

* SIZE 1 AND SIZE 3 ARE ALSO AVAILABLE

THIS PRODUCT HAS NOT
COMPLETED VALIDATION AND
QUALIFICATION TESTING

THIS DRAWING IS A CONTROLLED DOCUMENT.		DWN D. RINGLER 04SEP2008	TE Connectivity
DIMENSIONS:		CHK D. TROUT 04SEP2008	
TOLERANCES UNLESS OTHERWISE SPECIFIED:		APVD J. FEEDER 04SEP2008	NAME HEADER ASSEMBLY
0 PLC ±		PRODUCT SPEC	56/184/6P
2 PLC ±0.13		APPLICATION SPEC	STRADA MESA MEZZANINE CONNECTOR
3 PLC ±0.013		SIZE	A1
4 PLC ±		CAGE CODE	100779
ANGLES ±1		DRAWING NO	2057460
FINISH		RESTRICTED TO	
MATERIAL		WEIGHT	
		CUSTOMER DRAWING	SCALE 3:1 SHEET 1 OF 4 REV A

LOC	DIST	REVISIONS					
GP	00	P	LYN	DESCRIPTION	DATE	OWN	APVD
		-		SEE SHEET 1			

	41.8	42mm	MATTE Sn	9-2057460-2
	40.8	41mm	MATTE Sn	9-2057460-1
YES	39.8	40mm	MATTE Sn	9-2057460-0
	38.8	39mm	MATTE Sn	8-2057460-9
	37.8	38mm	MATTE Sn	8-2057460-8
	36.8	37mm	MATTE Sn	8-2057460-7
	35.8	36mm	MATTE Sn	8-2057460-6
	34.8	35mm	MATTE Sn	8-2057460-5
	33.8	34mm	MATTE Sn	8-2057460-4
	32.8	33mm	MATTE Sn	8-2057460-3
	31.8	32mm	MATTE Sn	8-2057460-2
	30.8	31mm	MATTE Sn	8-2057460-1
	29.8	30mm	MATTE Sn	8-2057460-0
	28.8	29mm	MATTE Sn	7-2057460-9
YES	27.8	28mm	MATTE Sn	7-2057460-8
	26.8	27mm	MATTE Sn	7-2057460-7
	25.8	26mm	MATTE Sn	7-2057460-6
	24.8	25mm	MATTE Sn	7-2057460-5
	23.8	24mm	MATTE Sn	7-2057460-4
YES	22.8	23mm	MATTE Sn	7-2057460-3
	21.8	22mm	MATTE Sn	7-2057460-2
	20.8	21mm	MATTE Sn	7-2057460-1
	19.8	20mm	MATTE Sn	7-2057460-0
	18.8	19mm	MATTE Sn	6-2057460-9
	17.8	18mm	MATTE Sn	6-2057460-8
	16.8	17mm	MATTE Sn	6-2057460-7
	15.8	16mm	MATTE Sn	6-2057460-6
	14.8	15mm	MATTE Sn	6-2057460-5
	13.8	14mm	MATTE Sn	6-2057460-4
	12.8	13mm	MATTE Sn	6-2057460-3
	11.8	12mm	MATTE Sn	6-2057460-2
	10.8	11mm	MATTE Sn	6-2057460-1
YES	9.8	10mm	MATTE Sn	6-2057460-0
YES	8.8	9mm	MATTE Sn	5-2057460-9
YES	7.8	8mm	MATTE Sn	5-2057460-8
TOOLED	DIM H	STACK HEIGHT	CONTACT TAIL PLATING	PART NUMBER

	41.8	42mm	Sn/Pb	4-2057460-2
	40.8	41mm	Sn/Pb	4-2057460-1
YES	39.8	40mm	Sn/Pb	4-2057460-0
	38.8	39mm	Sn/Pb	3-2057460-9
	37.8	38mm	Sn/Pb	3-2057460-8
	36.8	37mm	Sn/Pb	3-2057460-7
	35.8	36mm	Sn/Pb	3-2057460-6
	34.8	35mm	Sn/Pb	3-2057460-5
	33.8	34mm	Sn/Pb	3-2057460-4
	32.8	33mm	Sn/Pb	3-2057460-3
	31.8	32mm	Sn/Pb	3-2057460-2
	30.8	31mm	Sn/Pb	3-2057460-1
	29.8	30mm	Sn/Pb	3-2057460-0
	28.8	29mm	Sn/Pb	2-2057460-9
YES	27.8	28mm	Sn/Pb	2-2057460-8
	26.8	27mm	Sn/Pb	2-2057460-7
	25.8	26mm	Sn/Pb	2-2057460-6
	24.8	25mm	Sn/Pb	2-2057460-5
	23.8	24mm	Sn/Pb	2-2057460-4
YES	22.8	23mm	Sn/Pb	2-2057460-3
	21.8	22mm	Sn/Pb	2-2057460-2
	20.8	21mm	Sn/Pb	2-2057460-1
	19.8	20mm	Sn/Pb	2-2057460-0
	18.8	19mm	Sn/Pb	1-2057460-9
	17.8	18mm	Sn/Pb	1-2057460-8
	16.8	17mm	Sn/Pb	1-2057460-7
	15.8	16mm	Sn/Pb	1-2057460-6
	14.8	15mm	Sn/Pb	1-2057460-5
	13.8	14mm	Sn/Pb	1-2057460-4
	12.8	13mm	Sn/Pb	1-2057460-3
	11.8	12mm	Sn/Pb	1-2057460-2
	10.8	11mm	Sn/Pb	1-2057460-1
YES	9.8	10mm	Sn/Pb	1-2057340-0
YES	8.8	9mm	Sn/Pb	2057460-9
YES	7.8	8mm	Sn/Pb	2057460-8
TOOLED	DIM H	STACK HEIGHT	CONTACT TAIL PLATING	PART NUMBER

THIS DRAWING IS A CONTROLLED DOCUMENT.		OWN D. RINGLER 04SEP2008	 TE Connectivity
DIMENSIONS:		CHK D. TROUT 04SEP2008	
TOLERANCES UNLESS OTHERWISE SPECIFIED:		APVD J. EDDER 04SEP2008	NAME HEADER ASSEMBLY
0 PLC ± 1 PLC ±0.13 2 PLC ±0.13 3 PLC ±0.013 4 PLC ± ANGLES ±1 FINISH		PRODUCT SPEC 108-2375	APPLICATION SPEC
MATERIAL		114-13249	RESTRICTED TO
WEIGHT		A100779	SCALE 6:1 SHEET 2 OF 4 REV A
CUSTOMER DRAWING		C=2057460	

LOC	DIST	REVISIONS			
P	LTN	DESCRIPTION	DATE	DWN	APVD
-	-	SEE SHEET 1	-	-	-

A1 CORNER INDICATORS.

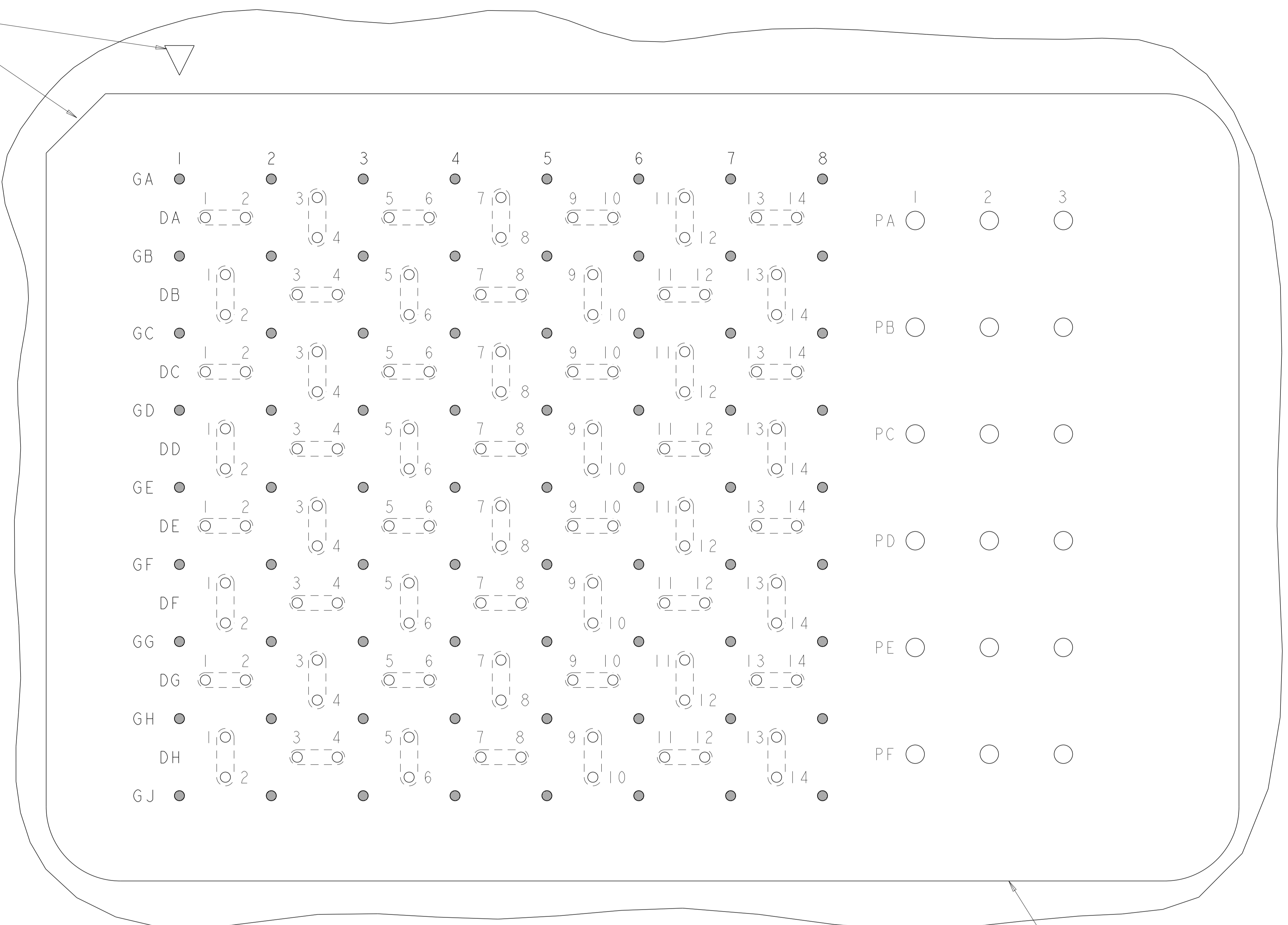

PCB LAYOUT AND PIN IDENTIFICATION 
 SHOWN FROM CONNECTOR SIDE
 SCALE 12:1

MATED CONNECTOR OUTLINE
 SEE SHEET 4 FOR LOCATION TO HOLES

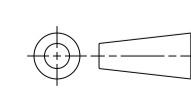
THIS DRAWING IS A CONTROLLED DOCUMENT.		DWN D. RINGLER 04SEP2008	 TE Connectivity
DIMENSIONS:		CHK D. TROUT 04SEP2008	
mm	TOLERANCES UNLESS OTHERWISE SPECIFIED:	APVD J. FEEDER 04SEP2008	NAME HEADER ASSEMBLY
	0 PLC ± 1 PLC ± 2 PLC ±0.13 3 PLC ±0.13 4 PLC ± ANGLES ±1	PRODUCT SPEC 108-2375	56/184/6P
MATERIAL	FINISH	APPLICATION SPEC 114-13249	STRADA MESA MEZZANINE CONNECTOR
		WEIGHT	SIZE CAGE CODE DRAWING NO A100779C=2057460
		CUSTOMER DRAWING	RESTRICTED TO SCALE 6:1 SHEET 3 OF 4 REV A

