



# CMOS Static RAM 64K (8K x 8-Bit)

**IDT7164S/LS**  
**IDT7164L/LL**

## Features

- ◆ **High-speed address/chip select access time**
  - Military: 20/25/35/45/55/70/85/100ns (max.)
  - Industrial: 25/35ns (max.)
  - Commercial: 15/20/25/35ns (max.)
- ◆ **Low power consumption**
- ◆ **Battery backup operation – 2V data retention voltage (L Version only)**
- ◆ **Produced with advanced CMOS high-performance technology**
- ◆ **Inputs and outputs directly TTL-compatible**
- ◆ **Three-state outputs**
- ◆ **Available in 28-pin DIP, CERDIP and SOJ**
- ◆ **Military product compliant to MIL-STD-883, Class B**

## Description

The IDT7164 is a 65,536 bit high-speed static RAM organized as 8K x 8. It is fabricated using IDT's high-performance, high-reliability CMOS technology.

Address access times as fast as 15ns are available and the circuit offers a reduced power standby mode. When  $\overline{CS}_1$  goes HIGH or  $CS_2$  goes LOW, the circuit will automatically go to, and remain in, a low-power standby mode. The low-power (L) version also offers a battery backup data retention capability at power supply levels as low as 2V.

All inputs and outputs of the IDT7164 are TTL-compatible and operation is from a single 5V supply, simplifying system designs. Fully static asynchronous circuitry is used, requiring no clocks or refreshing for operation.

The IDT7164 is packaged in a 28-pin 300 mil DIP and SOJ and a 28-pin 600 mil CERDIP.

Military grade product is manufactured in compliance with the latest revision of MIL-STD-883, Class B, making it ideally suited to military temperature applications demanding the highest level of performance and reliability.

## Functional Block Diagram

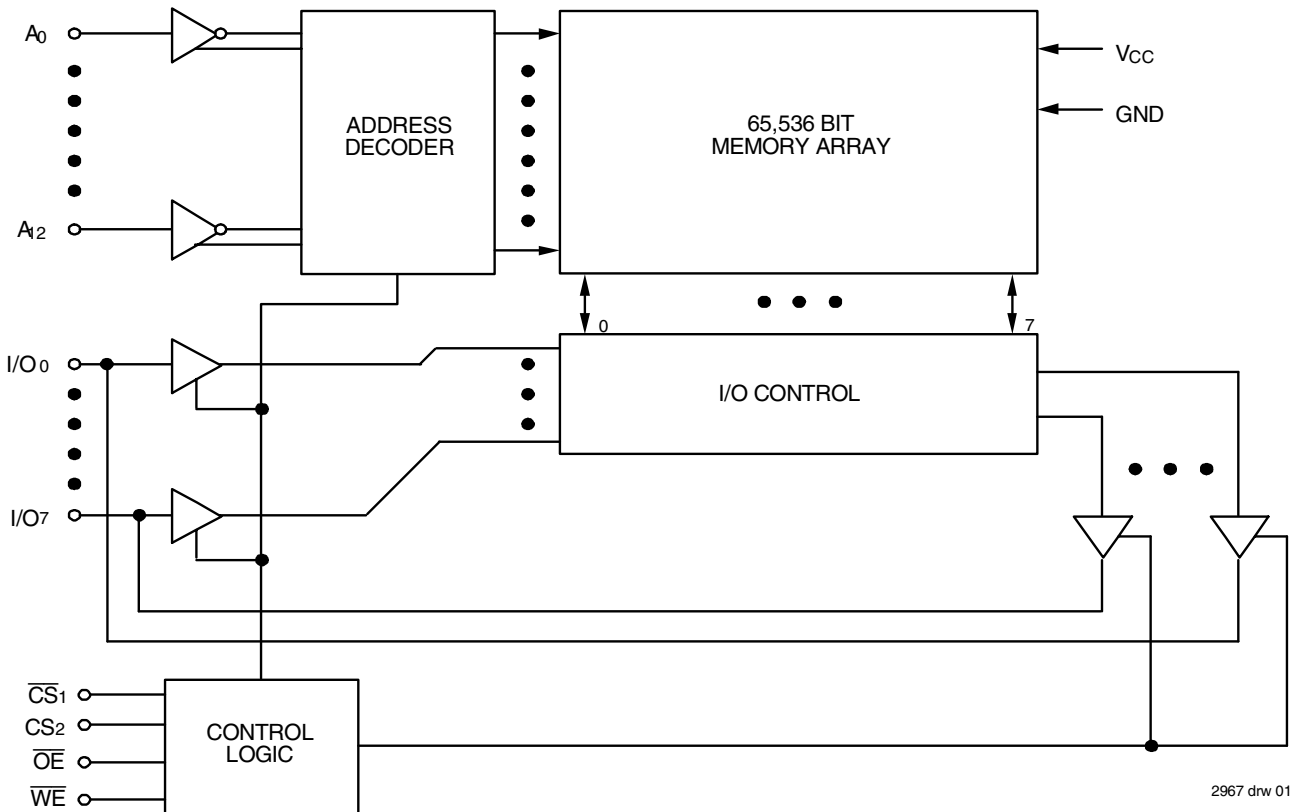

APRIL 2009

## Pin Configurations

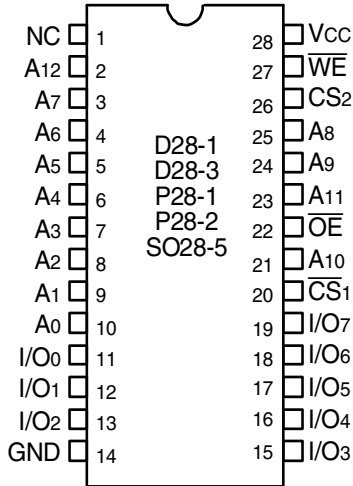

DIP/SOJ  
Top View

2967 drw 02

## Absolute Maximum Ratings<sup>(1)</sup>

Symbol	Rating	Com'l.	Mil.	Unit
$V_{TERM}^{(2)}$	Terminal Voltage with Respect to GND	-0.5 to +7.0	-0.5 to +7.0	V
$T_A$	Operating Temperature	0 to +70	-55 to +125	°C
$T_{BIAS}$	Temperature Under Bias	-55 to +125	-65 to +135	°C
$T_{STG}$	Storage Temperature	-55 to +125	-65 to +150	°C
$P_T$	Power Dissipation	1.0	1.0	W
$I_{OUT}$	DC Output Current	50	50	mA

2967 tbl 02

### NOTES:

- Stresses greater than those listed under ABSOLUTE MAXIMUM RATINGS may cause permanent damage to the device. This is a stress rating only and functional operation of the device at these or any other conditions above those indicated in the operational sections of this specification is not implied. Exposure to absolute maximum rating conditions for extended periods may affect reliability.
- $V_{TERM}$  must not exceed  $V_{CC} + 0.5V$ .

## Pin Descriptions

Name	Description
$A_0 - A_{12}$	Address
$I/O_0 - I/O_7$	Data Input/Output
$\overline{CS}_1$	Chip Select
$CS_2$	Chip Select
$\overline{WE}$	Write Enable
$\overline{OE}$	Output Enable
GND	Ground
$V_{CC}$	Power

2967 tbl 01

## Truth Table<sup>(1,2,3)</sup>

$\overline{WE}$	$\overline{CS}_1$	$CS_2$	$\overline{OE}$	I/O	Function
X	H	X	X	High-Z	Deselected - Standby (I <sub>SB</sub> )
X	X	L	X	High-Z	Deselected - Standby (I <sub>SB</sub> )
X	$V_{HC}$	$V_{HC}$ or $V_{LC}$	X	High-Z	Deselected - Standby (I <sub>SB1</sub> )
X	X	$V_{LC}$	X	High-Z	Deselected - Standby (I <sub>SB1</sub> )
H	L	H	H	High-Z	Output Disabled
H	L	H	L	DATA <sub>OUT</sub>	Read Data
L	L	H	X	DATA <sub>IN</sub>	Write Data

2967 tbl 03

### NOTES:

- $CS_2$  will power-down  $\overline{CS}_1$ , but  $\overline{CS}_1$  will not power-down  $CS_2$ .
- H =  $V_{IH}$ , L =  $V_{IL}$ , X = don't care.
- $V_{LC} = 0.2V$ ,  $V_{HC} = V_{CC} - 0.2V$

## Recommended DC Operating Conditions

Symbol	Parameter	Min.	Typ.	Max.	Unit
$V_{CC}$	Supply Voltage	4.5	5.0	5.5	V
GND	Ground	0	0	0	V
$V_{IH}$	Input HIGH Voltage	2.2	—	$V_{CC} + 0.5$	V
$V_{IL}$	Input LOW Voltage	-0.5 <sup>(1)</sup>	—	0.8	V

2967 tbl 05

### NOTE:

- $V_{IL}$  (min.) = -1.5V for pulse width less than 10ns, once per cycle.

## Recommended Operating Temperature and Supply Voltage

Grade	Temperature	GND	$V_{CC}$
Military	-55°C to +125°C	0V	5V ± 10%
Industrial	-40°C to +85°C	0V	5V ± 10%
Commercial	0°C to +70°C	0V	5V ± 10%

2967 tbl 04

### Capacitance ( $T_A = +25^\circ\text{C}$ , $f = 1.0\text{MHz}$ )

Symbol	Parameter <sup>(1)</sup>	Conditions	Max.	Unit
$C_{IN}$	Input Capacitance	$V_{IN} = 0V$	8	pF
$C_{IO}$	I/O Capacitance	$V_{OUT} = 0V$	8	pF

2967 tbl 06

**NOTE:**

1. This parameter is determined by device characterization, but is not production tested.

### DC Electrical Characteristics<sup>(1)</sup> ( $V_{CC} = 5.0V \pm 10\%$ , $V_{LC} = 0.2V$ , $V_{HC} = V_{CC} - 0.2V$ )

Symbol	Parameter	Power	7164S15 7164L15		7164S20 7164L20		7164S25 7164L25			Unit
			Com'l.	Ind.	Com'l.	Ind.	Mil.	Com'l.	Ind.	
ICC1	Operating Power Supply Current $\overline{CS}_1 = V_{IL}$ , $CS_2 = V_{IH}$ , Outputs Open $V_{CC} = \text{Max.}$ , $f = 0^{(2)}$	S	110	100	110	110	90	110	110	mA
		L	100	90	100	100	90	100	100	
ICC2	Dynamic Operating Current $\overline{CS}_1 = V_{IL}$ , $CS_2 = V_{IH}$ , Outputs Open $V_{CC} = \text{Max.}$ , $f = f_{MAX}^{(2)}$	S	180	170	170	180	170	170	180	mA
		L	150	150	150	160	150	150	160	
ISB	Standby Power Supply Current (TTL Level), $\overline{CS}_1 \geq V_{IH}$ , $CS_2 \leq V_{IL}$ , Outputs Open, $V_{CC} = \text{Max.}$ , $f = f_{MAX}^{(2)}$	S	20	20	20	20	20	20	20	mA
		L	3	3	3	5	3	3	5	
ISB1	Full Standby Power Supply Current (CMOS Level), $f = 0^{(2)}$ , $V_{CC} = \text{Max.}$ 1. $\overline{CS}_1 \geq V_{HC}$ and $CS_2 \geq V_{HC}$ , or 2. $CS_2 \leq V_{LC}$	S	15	15	15	20	15	15	20	mA
		L	0.2	0.2	0.2	1	0.2	0.2	1	

2967 tbl 07

Symbol	Parameter	Power	7164S35 7164L35			7164S45 7164L45	7164S55 7164L55	7164S70 7164L70	7164S85/100 7164L85/100	Unit
			Com'l.	Ind.	Mil.	Mil.	Mil.	Mil.	Mil.	
ICC1	Operating Power Supply Current $\overline{CS}_1 = V_{IL}$ , $CS_2 = V_{IH}$ , Outputs Open $V_{CC} = \text{Max.}$ , $f = 0^{(2)}$	S	90	110	100	100	100	100	100	mA
		L	90	100	90	90	90	90	90	
ICC2	Dynamic Operating Current $\overline{CS}_1 = V_{IL}$ , $CS_2 = V_{IH}$ , Outputs Open $V_{CC} = \text{Max.}$ , $f = f_{MAX}^{(2)}$	S	150	150	160	160	160	160	160	mA
		L	130	130	140	130	125	120	120	
ISB	Standby Power Supply Current (TTL Level), $\overline{CS}_1 \geq V_{IH}$ , $CS_2 \leq V_{IL}$ , Outputs Open, $V_{CC} = \text{Max.}$ , $f = f_{MAX}^{(2)}$	S	20	20	20	20	20	20	20	mA
		L	3	3	5	5	5	5	5	
ISB1	Full Standby Power Supply Current (CMOS Level), $f = 0^{(2)}$ , $V_{CC} = \text{Max.}$ 1. $\overline{CS}_1 \geq V_{HC}$ and $CS_2 \geq V_{HC}$ , or 2. $CS_2 \leq V_{LC}$	S	15	15	20	20	20	20	20	mA
		L	0.2	0.2	1	1	1	1	1	

2967 tbl 08

**NOTES:**

1. All values are maximum guaranteed values.
2.  $f_{MAX} = 1/TC$  (all address inputs are cycling at  $f_{MAX}$ );  $f = 0$  means no address input lines are changing.

## DC Electrical Characteristics (V<sub>CC</sub> = 5.0V ± 10%)

Symbol	Parameter	Test Conditions	IDT7164S		IDT7164L		Unit	
			Min.	Max.	Min.	Max.		
I <sub>LI</sub>	Input Leakage Current	V <sub>CC</sub> = Max., V <sub>IN</sub> = GND to V <sub>CC</sub>	MIL. COM'L. & IND	— 5	10 5	— 2	5 2	μA
I <sub>LO</sub>	Output Leakage Current	V <sub>CC</sub> = Max., $\overline{CS}_1 = V_{IH}$ , V <sub>OUT</sub> = GND to V <sub>CC</sub>	MIL. COM'L. & IND	— 5	10 5	— 2	5 2	μA
V <sub>OL</sub>	Output Low Voltage	I <sub>OL</sub> = 8mA, V <sub>CC</sub> = Min.	—	0.4	—	0.4	V	
		I <sub>OL</sub> = 10mA, V <sub>CC</sub> = Min.	—	0.5	—	0.5		
V <sub>OH</sub>	Output High Voltage	I <sub>OH</sub> = -4mA, V <sub>CC</sub> = Min.	2.4	—	2.4	—	V	

2967 tbl 09

## Data Retention Characteristics Over All Temperature Ranges (L Version Only) (V<sub>LC</sub> = 0.2V, V<sub>HC</sub> = V<sub>CC</sub> - 0.2V)

Symbol	Parameter	Test Condition	Min.	Typ. <sup>(1)</sup> V <sub>CC</sub> @		Max. V <sub>CC</sub> @		Unit
				2.0V	3.0V	2.0V	3.0V	
V <sub>DR</sub>	V <sub>CC</sub> for Data Retention	—	2.0	—	—	—	—	V
I <sub>CCDR</sub>	Data Retention Current	MIL. COM'L. & IND	— —	10 10	15 15	200 60	300 90	μA
t <sub>CDR</sub> <sup>(3)</sup>	Chip Deselect to Data Retention Time	1. $\overline{CS}_1 \geq V_{HC}$ CS <sub>2</sub> ≥ V <sub>HC</sub> , or 2. CS <sub>2</sub> ≤ V <sub>LC</sub>	0	—	—	—	—	ns
t <sub>R</sub> <sup>(3)</sup>	Operation Recovery Time		t <sub>RC</sub> <sup>(2)</sup>	—	—	—	—	ns
I <sub>LI</sub> <sup>(3)</sup>	Input Leakage Current		—	—	—	2	2	μA

2967 tbl 10

### NOTES:

- TA = +25°C.
- t<sub>RC</sub> = Read Cycle Time.
- This parameter is guaranteed by device characterization, but is not production tested.

## AC Test Conditions

Input Pulse Levels	GND to 3.0V
Input Rise/Fall Times	5ns
Input Timing Reference Levels	1.5V
Output Reference Levels	1.5V
AC Test Load	See Figures 1 and 2

2967 tbl 11

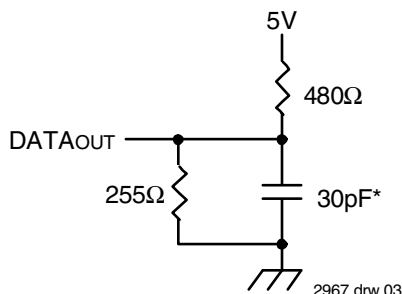

Figure 1. AC Test Load

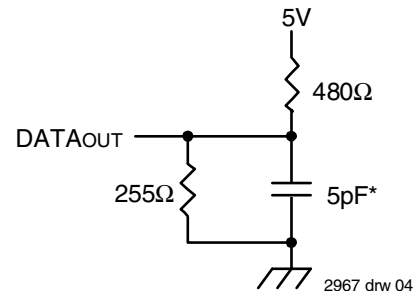

Figure 2. AC Test Load

(for t<sub>CLZ1</sub>, t<sub>CLZ2</sub>, t<sub>OLZ</sub>, t<sub>CHZ1</sub>, t<sub>CHZ2</sub>, t<sub>OHZ</sub>, t<sub>ow</sub>, and t<sub>whz</sub>)

\*Includes scope and jig capacitances

AC Electrical Characteristics (V<sub>CC</sub> = 5.0V ± 10%, All Temperature Ranges)

Symbol	Parameter	7164S15 <sup>(1)</sup> 7164L15 <sup>(1)</sup>		7164S20 <sup>(2)</sup> 7164L20 <sup>(2)</sup>		7164S25 7164L25		7164S35 7164L35		Unit
		Min.	Max.	Min.	Max.	Min.	Max.	Min.	Max.	
<b>Read Cycle</b>										
t <sub>RC</sub>	Read Cycle Time	15	—	20	—	25	—	35	—	ns
t <sub>AA</sub>	Address Access Time	—	15	—	19	—	25	—	35	ns
t <sub>ACS1</sub> <sup>(3)</sup>	Chip Select-1 Access Time	—	15	—	20	—	25	—	35	ns
t <sub>ACS2</sub> <sup>(3)</sup>	Chip Select-2 Access Time	—	20	—	25	—	30	—	40	ns
t <sub>CLZ1,2</sub> <sup>(4)</sup>	Chip Select-1, 2 to Output in Low-Z	5	—	5	—	5	—	5	—	ns
t <sub>OE</sub>	Output Enable to Output Valid	—	7	—	8	—	12	—	18	ns
t <sub>OLZ</sub> <sup>(4)</sup>	Output Enable to Output in Low-Z	0	—	0	—	0	—	0	—	ns
t <sub>CHZ1,2</sub> <sup>(4)</sup>	Chip Select-1,2 to Output in High-Z	—	8	—	9	—	13	—	15	ns
t <sub>OHZ</sub> <sup>(4)</sup>	Output Disable to Output in High-Z	—	7	—	8	—	10	—	15	ns
t <sub>OH</sub>	Output Hold from Address Change	5	—	5	—	5	—	5	—	ns
t <sub>PU</sub> <sup>(4)</sup>	Chip Select to Power Up Time	0	—	0	—	0	—	0	—	ns
t <sub>PD</sub> <sup>(4)</sup>	Chip Deselect to Power Down Time	—	15	—	20	—	25	—	35	ns
<b>Write Cycle</b>										
t <sub>WC</sub>	Write Cycle Time	15	—	20	—	25	—	35	—	ns
t <sub>CW1,2</sub>	Chip Select to End-of-Write	14	—	15	—	18	—	25	—	ns
t <sub>AW</sub>	Address Valid to End-of-Write	14	—	15	—	18	—	25	—	ns
t <sub>AS</sub>	Address Set-up Time	0	—	0	—	0	—	0	—	ns
t <sub>WP</sub>	Write Pulse Width	14	—	15	—	21	—	25	—	ns
t <sub>WR1</sub>	Write Recovery Time ( $\overline{CS}_1, \overline{WE}$ )	0	—	0	—	0	—	0	—	ns
t <sub>WR2</sub>	Write Recovery Time (CS <sub>2</sub> )	5	—	5	—	5	—	5	—	ns
t <sub>WHZ</sub> <sup>(4)</sup>	Write Enable to Output in High-Z	—	6	—	8	—	10	—	14	ns
t <sub>DW</sub>	Data to Write Time Overlap	8	—	10	—	13	—	15	—	ns
t <sub>DH1</sub>	Data Hold from Write Time ( $\overline{CS}_1, \overline{WE}$ )	0	—	0	—	0	—	0	—	ns
t <sub>DH2</sub>	Data Hold from Write Time (CS <sub>2</sub> )	5	—	5	—	5	—	5	—	ns
t <sub>OW</sub> <sup>(4)</sup>	Output Active from End-of-Write	4	—	4	—	4	—	4	—	ns

NOTES:

- 0° to +70°C temperature range only.
- 0° to +70°C and -55°C to +125°C temperature ranges only.
- Both chip selects must be active for the device to be selected.
- This parameter is guaranteed by device characterization, but is not production tested.

## AC Electrical Characteristics (con't.) (V<sub>CC</sub> = 5.0V ± 10%, Military Temperature Ranges)

Symbol	Parameter	7164S45 7164L45		7164S55 7164L55		7164S70 7164L70		7164S85/100 7164L85/100		Unit
		Min.	Max.	Min.	Max.	Min.	Max.	Min.	Max.	
<b>Read Cycle</b>										
t <sub>RC</sub>	Read Cycle Time	45	—	55	—	70	—	85/100	—	ns
t <sub>AA</sub>	Address Access Time	—	45	—	55	—	70	—	85/100	ns
t <sub>ACS1</sub> <sup>(1)</sup>	Chip Select-1 Access Time	—	45	—	55	—	70	—	85/100	ns
t <sub>ACS2</sub> <sup>(1)</sup>	Chip Select-2 Access Time	—	45	—	55	—	70	—	85/100	ns
t <sub>CLZ1,2</sub> <sup>(2)</sup>	Chip Select-1, 2 to Output in Low-Z	5	—	5	—	5	—	5	—	ns
t <sub>OE</sub>	Output Enable to Output Valid	—	25	—	30	—	35	—	40	ns
t <sub>OLZ</sub> <sup>(2)</sup>	Output Enable to Output in Low-Z	0	—	0	—	0	—	0	—	ns
t <sub>CHZ1,2</sub> <sup>(2)</sup>	Chip Select-1,2 to Output in High-Z	—	20	—	25	—	30	—	35	ns
t <sub>OHZ</sub> <sup>(2)</sup>	Output Disable to Output in High-Z	—	20	—	25	—	30	—	35	ns
t <sub>OH</sub>	Output Hold from Address Change	5	—	5	—	5	—	5	—	ns
t <sub>PU</sub> <sup>(2)</sup>	Chip Select to Power Up Time	0	—	0	—	0	—	0	—	ns
t <sub>PD</sub> <sup>(2)</sup>	Chip Deselect to Power Down Time	—	45	—	55	—	70	—	85/100	ns
<b>Write Cycle</b>										
t <sub>WC</sub>	Write Cycle Time	45	—	55	—	70	—	85/100	—	ns
t <sub>CW1,2</sub>	Chip Select to End-of-Write	33	—	50	—	60	—	75	—	ns
t <sub>AW</sub>	Address Valid to End-of-Write	33	—	50	—	60	—	75	—	ns
t <sub>AS</sub>	Address Set-up Time	0	—	0	—	0	—	0	—	ns
t <sub>WP</sub>	Write Pulse Width	25	—	50	—	60	—	75	—	ns
t <sub>WR1</sub>	Write Recovery Time ( $\overline{CS}_1, \overline{WE}$ )	0	—	0	—	0	—	0	—	ns
t <sub>WR2</sub>	Write Recovery Time (CS <sub>2</sub> )	5	—	5	—	5	—	5	—	ns
t <sub>WHZ</sub> <sup>(2)</sup>	Write Enable to Output in High-Z	—	18	—	25	—	30	—	35	ns
t <sub>DW</sub>	Data to Write Time Overlap	20	—	25	—	30	—	35	—	ns
t <sub>DH1</sub>	Data Hold from Write Time ( $\overline{CS}_1, \overline{WE}$ )	0	—	0	—	0	—	0	—	ns
t <sub>DH2</sub>	Data Hold from Write Time (CS <sub>2</sub> )	5	—	5	—	5	—	5	—	ns
t <sub>OW</sub> <sup>(2)</sup>	Output Active from End-of-Write	4	—	4	—	4	—	4	—	ns

2967 tbl 13

**NOTES:**

- Both chip selects must be active for the device to be selected.
- This parameter is guaranteed by device characterization, but is not production tested.

### Timing Waveform of Read Cycle No. 1<sup>(1)</sup>

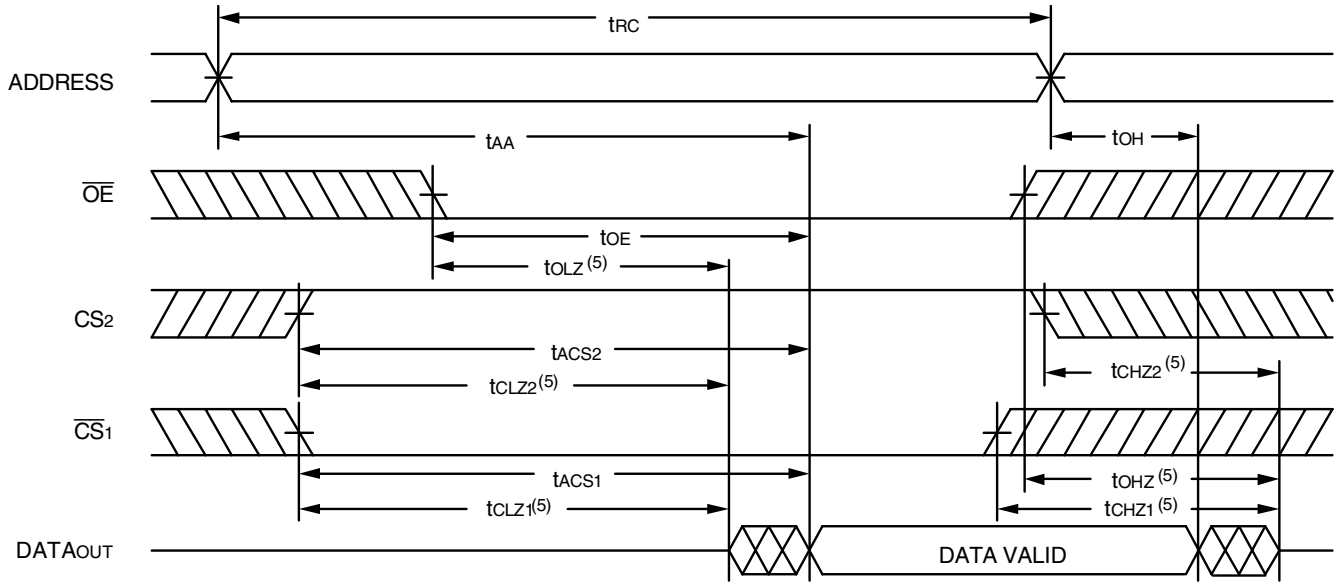

2967 drw 05

### Timing Waveform of Read Cycle No. 2<sup>(1,2,4)</sup>

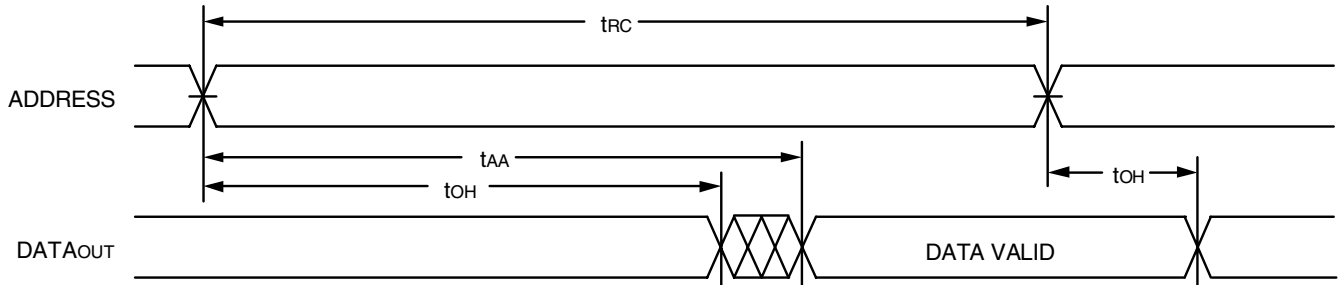

2967 drw 06

### Timing Waveform of Read Cycle No. 3<sup>(1,3,4)</sup>

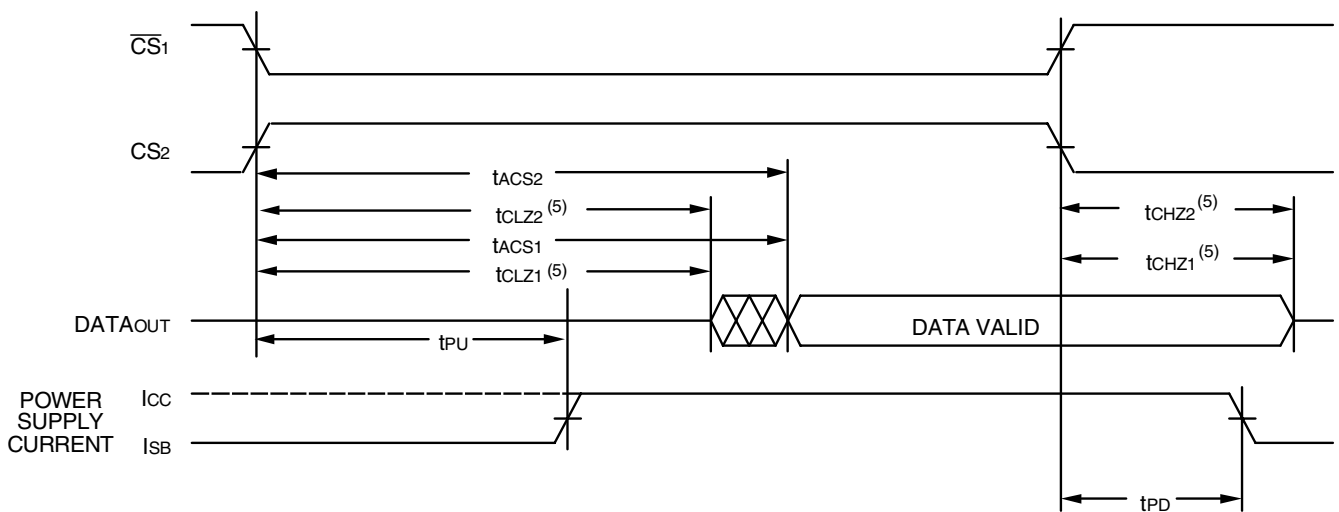

**NOTES:**

1.  $\overline{WE}$  is HIGH for Read cycle.
2. Device is continuously selected,  $\overline{CS1}$  is LOW,  $CS2$  is HIGH.
3. Address valid prior to or coincident with  $\overline{CS1}$  transition LOW and  $CS2$  transition HIGH.
4.  $\overline{OE}$  is LOW.
5. Transition is measured  $\pm 200\text{mV}$  from steady state.

2967 drw 07

### Timing Waveform of Write Cycle No. 1 ( $\overline{WE}$ Controlled Timing)<sup>(1,5)</sup>

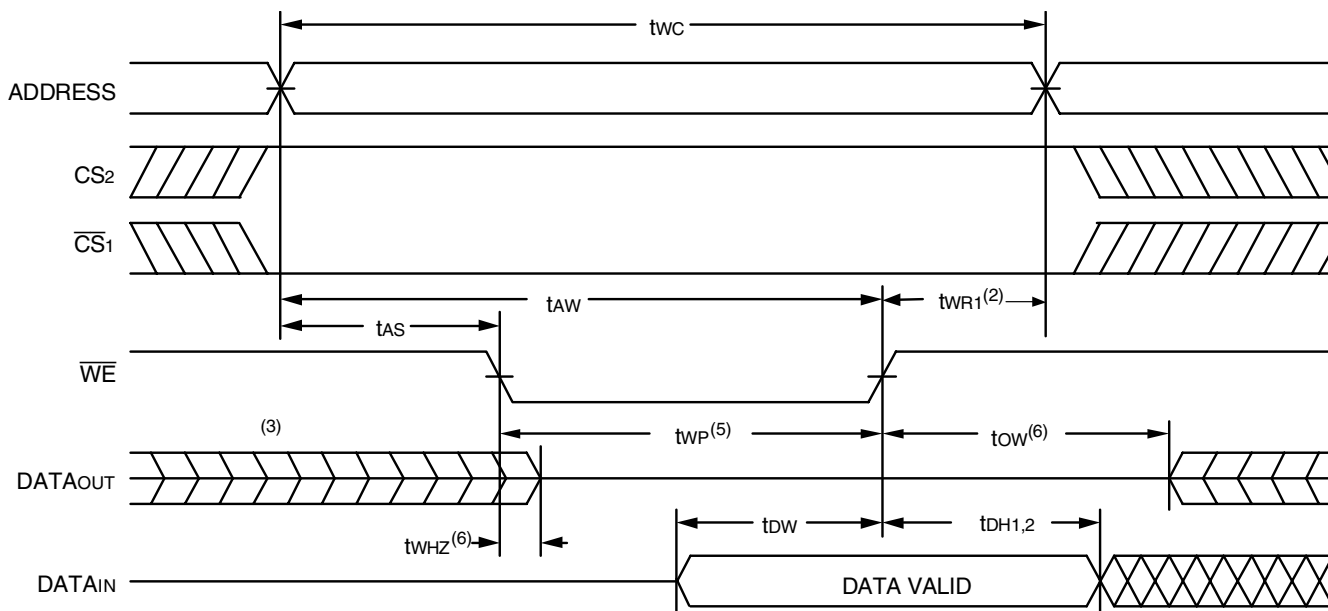

2967 drw 08

### Timing Waveform of Write Cycle No. 2 ( $\overline{CS}$ Controlled Timing)<sup>(1)</sup>

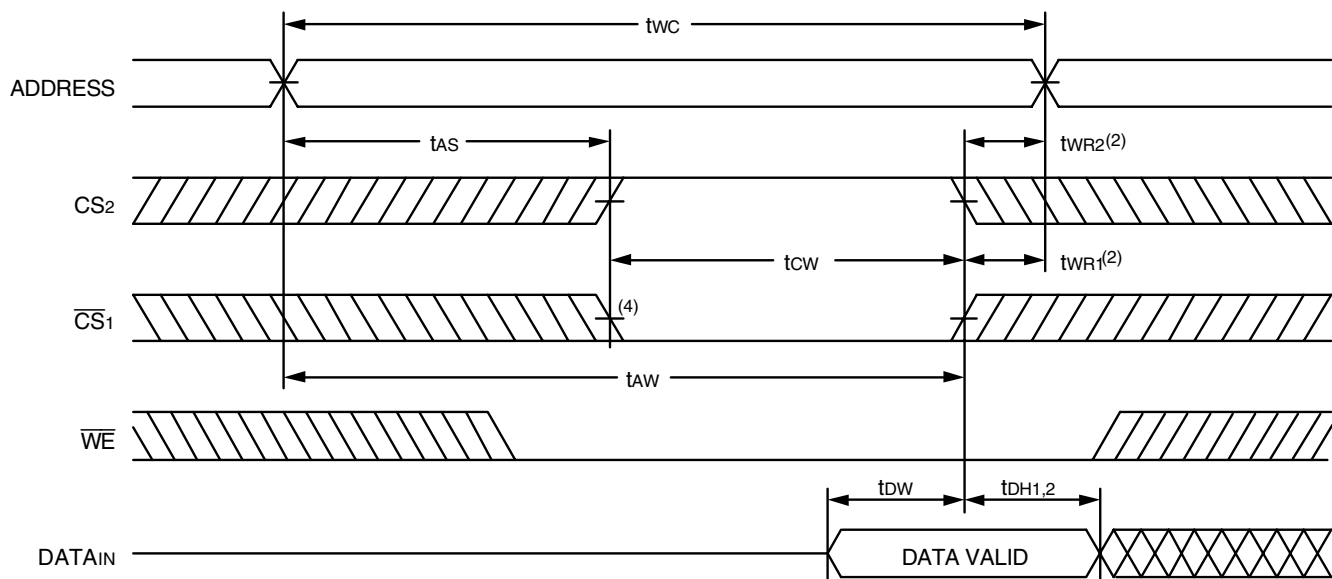

2967 drw 09

#### NOTES:

1. A write occurs during the overlap of a LOW  $\overline{WE}$ , a LOW  $\overline{CS}_1$  and a HIGH  $CS_2$ .
2.  $t_{WR1,2}$  is measured from the earlier of  $\overline{CS}_1$  or  $\overline{WE}$  going HIGH or  $CS_2$  going LOW to the end of the write cycle.
3. During this period, I/O pins are in the output state so that the input signals must not be applied.
4. If the  $\overline{CS}_1$  LOW transition or  $CS_2$  HIGH transition occurs simultaneously with or after the  $\overline{WE}$  LOW transition, the outputs remain in a high-impedance state.
5.  $\overline{OE}$  is continuously HIGH. If  $\overline{OE}$  is LOW during a  $\overline{WE}$  controlled write cycle, the write pulse width must be the larger of  $t_{WP}$  or  $(t_{WHZ} + t_{DW})$  to allow the I/O drivers to turn off and data to be placed on the bus for the required  $t_{OW}$ . If  $\overline{OE}$  is HIGH during a  $\overline{WE}$  controlled write cycle, this requirement does not apply and the minimum write pulse width is as short as the specified  $t_{WP}$ .
6. Transition is measured  $\pm 200mV$  from steady state.



### Low Vcc Data Retention Waveform

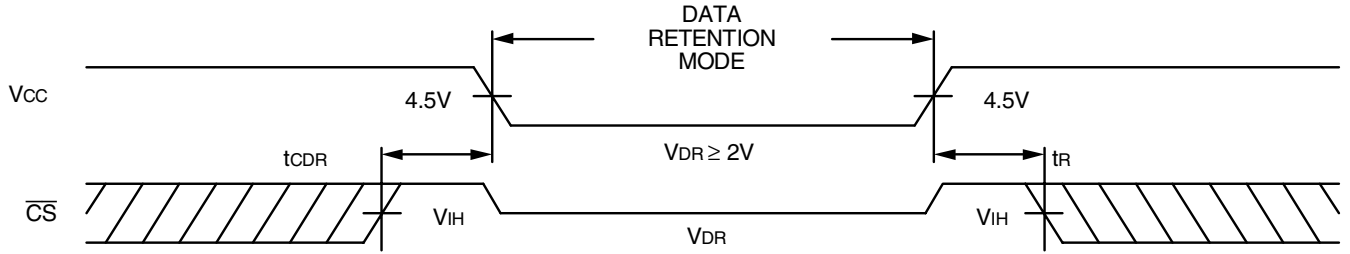

2967 drw 10

### Ordering Information — Commercial

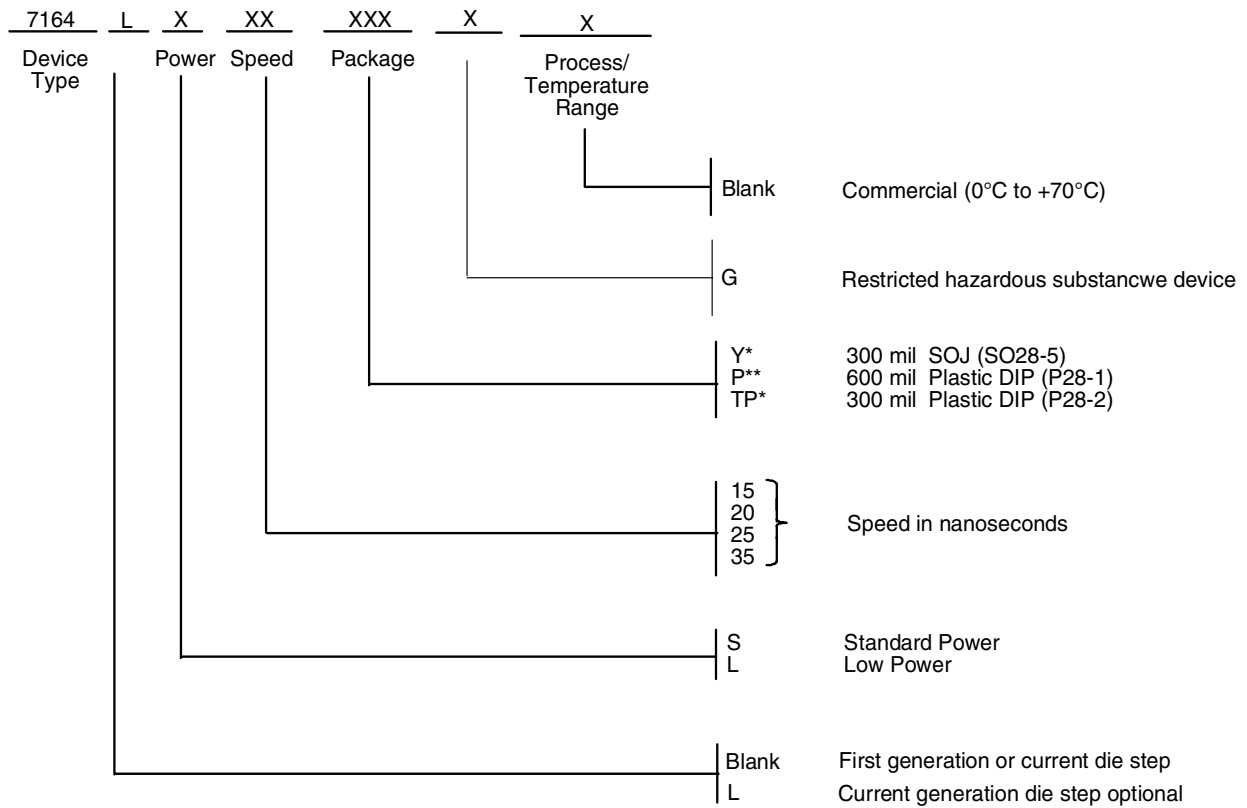

\* Available for 15ns and 20ns speed grades only.  
\*\* Available for 25ns and 35ns speed grades only.

2967 drw 11

## Ordering Information — Industrial

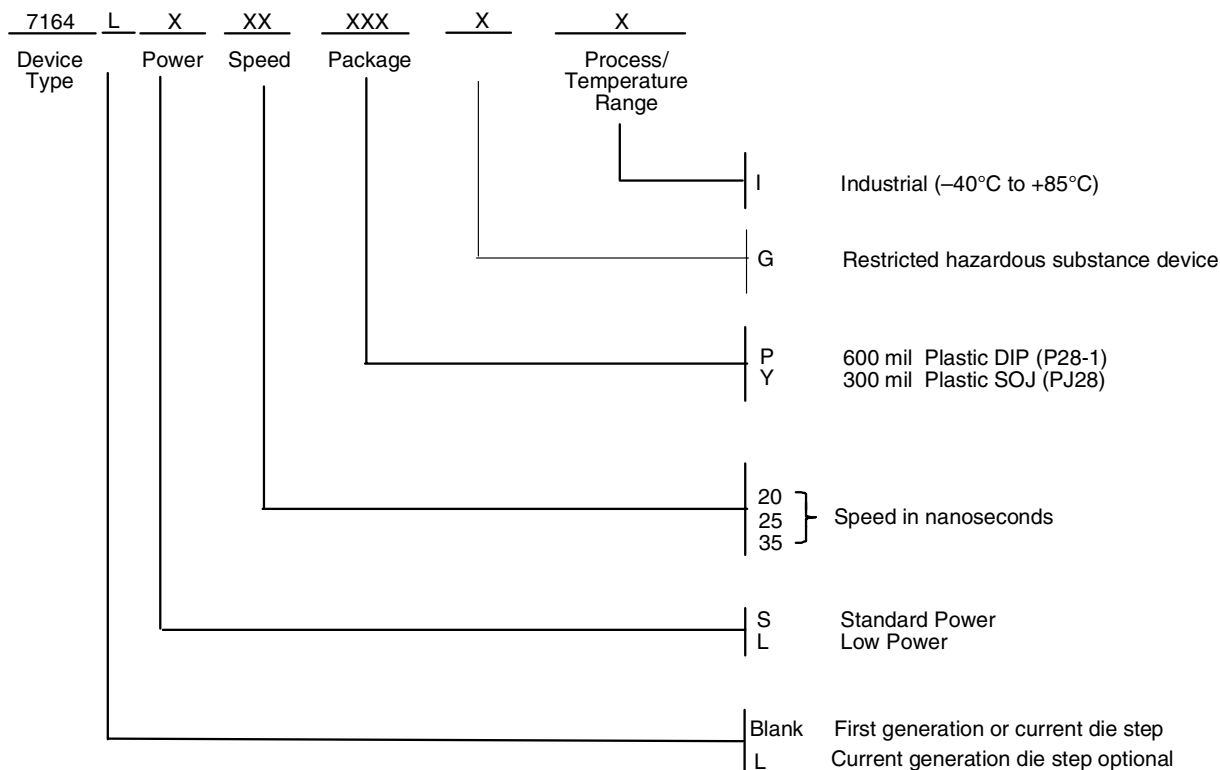

## Ordering Information — Military

2967 drw 12

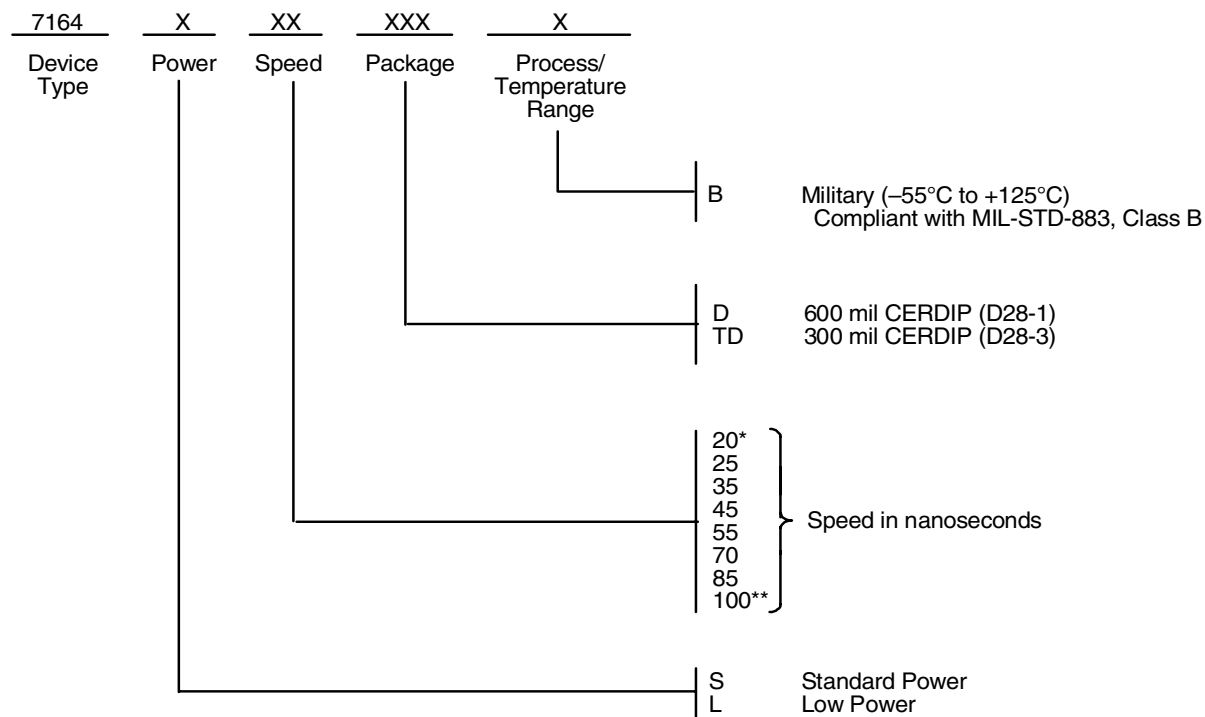

\* Available only in 600mil CERDIP (D28-1) and 300mil CERDIP (D28-1) and 300mil CERDIP (D28-3) packaging for a low power.  
\*\* Available only in 600 mil CERDIP (D28-1) packaging.

2967 drw 13

## Datasheet Document History

1/13/2000		Updated to new format
	Pp. 1, 2, 3, 5, 10	Added Industrial Temperature range offerings
	Pp. 1, 3, 9	Removed commercial 70ns speed grade offering
	Pp. 1, 3, 6, 10	Added 100ns speed grade specification details
	Pg. 3	Revised notes and footnotes in DC Electrical tables
	Pp. 5, 6	Revised notes and footnotes in AC Electrical tables
	Pg. 8	Removed Note 1 from Write Cycle No. 1 and No. 2 diagrams; renumbered notes and footnotes
	Pp. 9, 10	Separated Ordering Information into commercial, industrial, and military offerings
	Pg. 11	Added Datasheet Document History
08/09/00		Not recommended for new designs
02/01/01		Removed "Not recommended for new designs"
12/07/01	Pg. 10	Add PJ28 to Industrial temperature.
09/30/04	Pg. 9,10	Added "restricted hazardous substance device" to ordering information.
11/16/06	Pg.3	Added industrial temp power limits for 20ns part. Changed power limits for 25ns part for commercial and industrial. Changed power limits for commercial and industrial for 35ns part.
	Pg.10	Added 20ns part to ordering information. Refer to PCN SR-0602-01
02/20/07	Pg. 9, 10	Added L generation die step to data sheet ordering information.
04/01/09	Pg. 9,10	Removed "IDT" from ordering part number.



**CORPORATE HEADQUARTERS**  
6024 Silver Creek Valley Road  
San Jose, CA 95138

**for SALES:**  
800-345-7015 or  
408-284-8200  
fax: 408-284-2775  
www.idt.com

**for Tech Support:**  
ipchelp@idt.com  
800-345-7015