

DRAWING MADE IN THIRD ANGLE PROJECTION
 THIS DRAWING IS UNPUBLISHED. RELEASED FOR PUBLICATION .19
 © COPYRIGHT 19 BY AMP INCORPORATED. ALL INTERNATIONAL RIGHTS RESERVED.

LOC		DIST		REVISIONS			
ZONE	LTR	DESCRIPTION	DATE	APPD			
G	86	P	F	B	ECR-17-006035	02JUN17	M

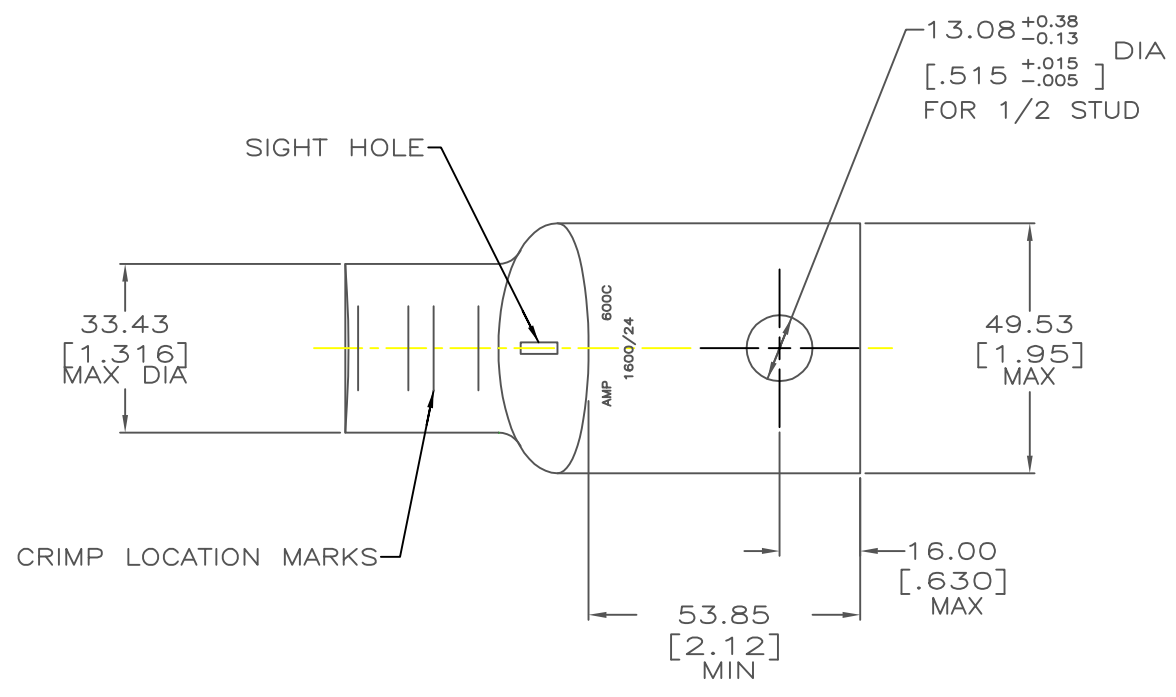

1 CIRCULAR MIL RANGE: 550-650 MCM

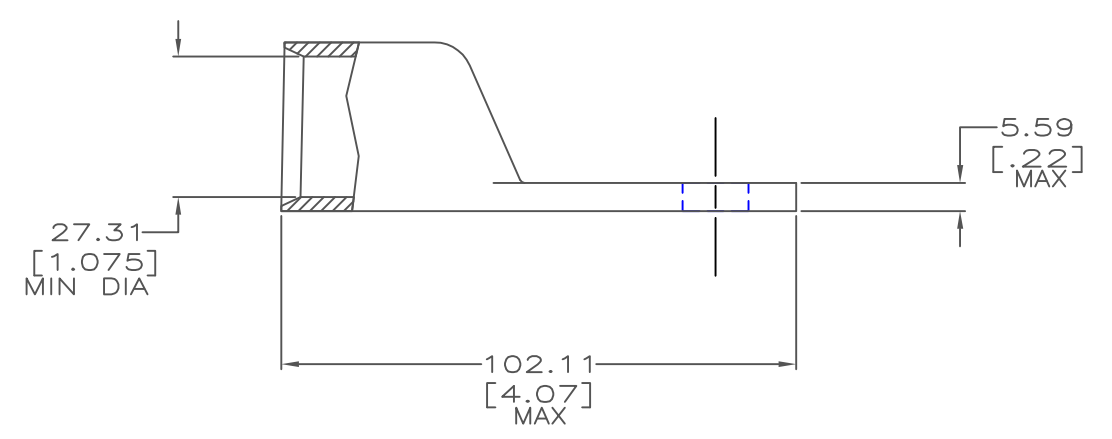

55842

55842-1
PART NO

DO NOT SCALE PRINT. UNLESS SPECIFIED DIMENSIONS IN mm [INCHES] TOLERANCES ON : 2 PLC DEC ± 0.50[.020] 3 PLC DEC ± - ANGLES ± -		DR 7/21/92 DK SCHRUM	AMP AMP Incorporated Harrisburg, PA 17105-3608
MATERIAL COPPER ASTM B-75 ANNEALED		CHK 7/21/92 AJ KAUFMAN	
FINISH TIN PLATE 0.00254[.000100] MIN THK PER MIL-T-10727		APPD 7/21/92 WJ VOCKROTH	NAME TERMINAL, RECTANGULAR TONGUE, AMPOWER, WIRE SIZE: 304.0mm[600] MCM
THIS DRAWING IS A CONTROLLED DOCUMENT FOR AMP INCORPORATED. IT IS SUBJECT TO CHANGE AND THE CONTROLLING ENGINEERING ORGANIZATION SHOULD BE CONTACTED FOR THE LATEST REVISION.		APPD 7/21/92 CR RHOADS	SIZE CAGE CODE DRAWING NO C 00779 C-55842
		PRODUCT SPEC -	SCALE 1:1 SHEET 10F 1
		APPLICATION SPEC -	
		WEIGHT -	

CUSTOMER DRAWING