

**FG-23652-D65**

**SHT 1.1**

NOTES:

- INCREASED PRESSURE AT THE SOUND INLET CAUSES A POSITIVE GOING VOLTAGE TO APPEAR AT THE OUTPUT TERMINAL, RELATIVE TO THE NEGATIVE TERMINAL.

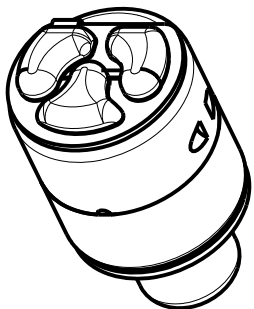
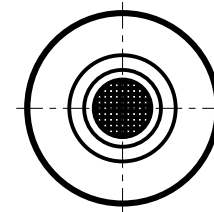
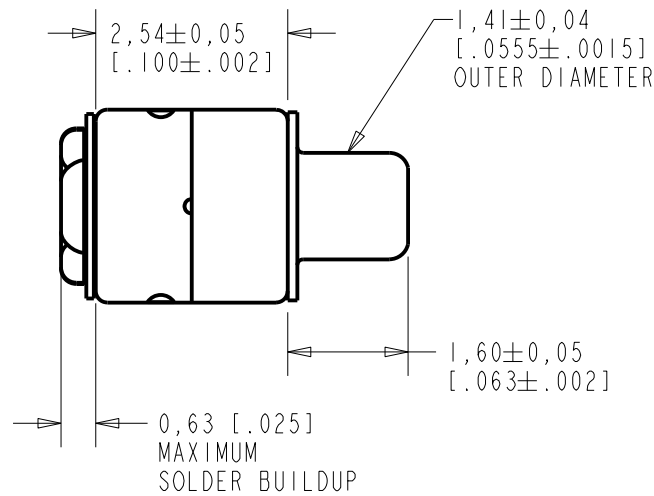
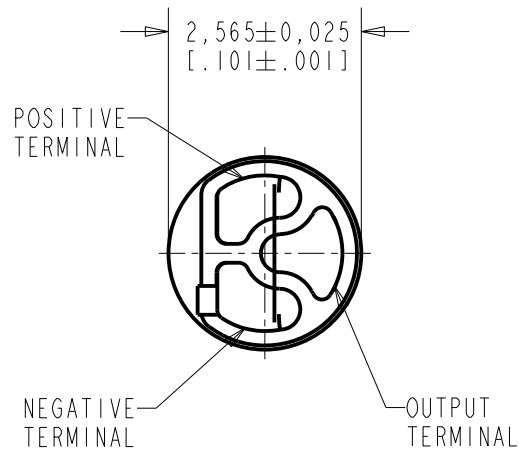

DIMENSIONS IN MILLIMETERS [INCHES]

Revision	C.O. #	Implementation Date	RELEASE LEVEL	REVISION
E	MI0104983	3-13-13	Active	E
D	MI0104555	5-2-12		

SCALE:	<b>10:1</b>	DR. BY	DATE
DO NOT SCALE DRAWING		SDZ	7-27-09
TITLE:	<b>MICROPHONE</b>	CK. BY	DATE
	<b>OUTLINE DRAWING</b>	GJP	7-27-09
		APP. BY	DATE
		GJP	7-27-09

**KNOWLES ELECTRONICS**  
ITASCA, ILLINOIS U.S.A.

**FC-23652-D65**

**SHT 1.1**

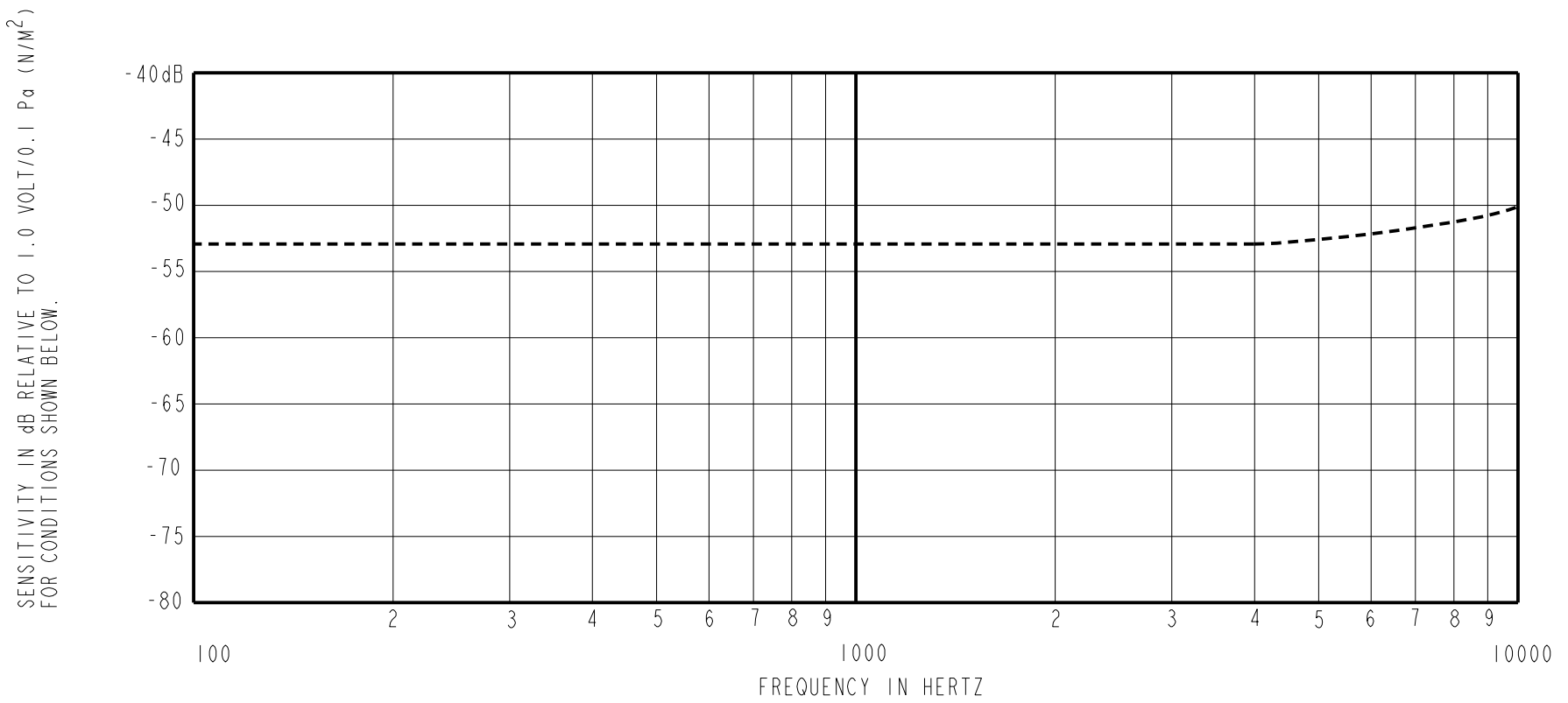

FREQUENCY	SENSITIVITY			DEVICE CONFORMITY	
	MIN.	NOM.	MAX.	RANGE OF DEVIATION FROM 1KHz	
100	---	-53.0	---	-3.0	+3.0
1000	-56.0	-53.0	-50.0	0.0	0.0
10000	---	-48.0	---	+2.0	+8.0

- NOTES: 1. CASE CONNECTED TO NEGATIVE TERMINAL.  
2. MICROPHONE TO BE FUNCTIONAL WITH 3.0 VDC SUPPLY.  
3. TYPICAL SENSITIVITY TO HUMIDITY AT 1000Hz IS 0.06 dB/%RH  
4. SENSITIVITY AND NOISE VALUES INDICATED ON THIS SPECIFICATION ARE VALID AT 50% HUMIDITY.

PORT LOCATION	DC SUPPLY	AMPLIFIER CURRENT DRAIN	SENSITIVITY CHANGE ON CHANGING SUPPLY TO 0.9VDC AND 3.0 VDC	"A" WEIGHTED NOISE (1 kHz EQUIV. SPL)	OUTPUT IMPEDANCE OHMS		
					MIN.	NOM.	MAX.
I2S	1.3V	50 µA MAX.	3 dB MAX.	28.0 dB MAX.	2800	4400	6800

Revision	C.O. #	Implementation Date	RELEASE LEVEL	REVISION
E	M10104983	3-13-13	<b>Active</b>	<b>E</b>
D	M10104555	5-2-12		

WHEN TEST LIMITS ARE USED TO ESTABLISH INCOMING INSPECTION ACCEPTANCE/REJECTION CRITERIA, CORRELATION OF TEST EQUIPMENT WITH KNOWLES IS ALSO REQUIRED FOR ELIMINATION OF EQUIPMENT AND TEST METHOD VARIATION		DR. BY	DATE
		SDZ	7-27-09
		CK. BY	DATE
		GJP	7-27-09
		APP. BY	DATE
		GJP	7-27-09

TITLE:	<b>MICROPHONE</b>	<b>FG-23652-D65</b>
	PERFORMANCE SPECIFICATION	SHT 2.1

**KNOWLES ELECTRONICS**  
ITASCA, ILLINOIS U.S.A.