

SIL Resistor Network

L Series

- Thick Film
- Low Profile SIP
- Conformal Coated
- Resistor Networks
- RoHS Compliant



 All parts are Pb-free and comply with EU Directive 2011/65/EU amended by (EU) 2015/863 (RoHS3)

Electrical

Standard Resistance Range, Ohms	1%: 22R - 1M; 2%:10R - 5M6; 5%: 10R - 10M
Standard Resistance Tolerance, at 25°C	±2% Optional: ±1% (F Tol.), ±5% (J Tol.)
Operating Temperature Range	-55°C to +125°C
Temperature Coefficient of Resistance	±100ppm/°C (<50 Ohms = ±250ppm/°C)
Temperature Coefficient of Resistance, Tracking	±50ppm/°C
Element Power Rating @70°C	Circuits -1 & -5: 125mW, circuit -3: 200mW
Package Power Rating @70°C	100mW per pin
Maximum Operating Voltage	100Vdc or VPR
Insulation Resistance	≥10,000 Megohms

Environmental

Thermal Shock plus Power Conditioning	ΔR 0.70%
Short Time Overload	ΔR 0.25%
Terminal Strength	ΔR 0.25%
Moisture Resistance	ΔR 0.50%
Mechanical Shock	ΔR 0.25%
Vibration	ΔR 0.25%
Low Temperature Storage	ΔR 0.25%
High Temperature Exposure	ΔR 0.50%
Load Life, 1,000 Hours	ΔR 1.00%
Resistance to Solder Heat (Per MIL-STD-202, Method 210, Cond.B)	ΔR 0.25%
Dielectric Withstand Voltage	200V for 1 minute
Marking Permanency	MIL-STD 202, Method 215
Lead Solderability	MIL-STD 202, Method 208
Flammability	UL-94V-O Rated
Storage Temperature Range	-55°C to +150°C

Specifications subject to change without notice.

General Note

TT Electronics reserves the right to make changes in product specification without notice or liability.
All information is subject to TT Electronics' own data and is considered accurate at time of going to print.

L Series

Mechanical

Lead Finish	SnAgCu
Substrate Material	Alumina
Resistor Material	Cermet
Body Material	Conformal Epoxy Resin, red or black

Standard Resistance Values, Ohms

Power Derating Curve

-3 Circuit (Isolated Resistors) & -1 Circuits (Bussed Resistors)					
Ohms	Code	Ohms	Code	Ohms	Code
22	220	820	821	33K	333
27	270	1K	102	39K	393
33	330	1.2K	122	47K	473
39	390	1.5K	152	51K	513
47	470	1.8K	182	56K	563
51	510	2K	202	68K	683
56	560	2.2K	222	82K	823
68	680	2.7K	272	100K	104
82	820	3.3K	332	120K	124
100	101	3.9K	392	150K	154
120	121	4.7K	472	180K	184
150	151	5.1K	512	200K	204
180	181	5.6K	562	220K	224
200	201	6.8K	682	270K	274
220	221	8.2K	822	330K	334
270	271	10K	103	390K	394
330	331	12K	123	470K	474
390	391	15K	153	510K	514
470	471	18K	183	560K	564
510	511	20K	203	680K	684
560	561	22K	223	820K	824
680	681	27K	273	1Meg	105
-5 Circuit (Dual Terminators)					
Ohms	Code	Ohms	Code	Ohms	Code
R1/R2	R1/R2	R1/R2	R1/R2	R1/R2	R1/R2
180/390	181/391	330/390	331/391	3K/6.2K	302/622
220/270	221/271	330/470	331/471	-	-
220/330	221/331	330/680	331/681	-	-

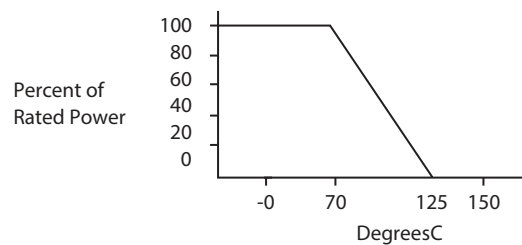

General Note

TT Electronics reserves the right to make changes in product specification without notice or liability. All information is subject to TT Electronics' own data and is considered accurate at time of going to print.

L Series

Outline Dimensions (Inch/mm)

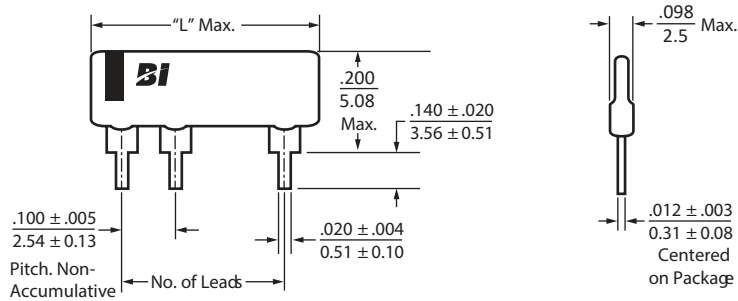

# of Leads	4	5	6	7	8	9	10	11	12	13	14
Dim. "L" Max.	.40 10.16	.50 12.70	.60 15.24	.70 17.78	.80 20.32	.90 22.86	1.00 25.40	1.10 27.94	1.20 30.48	1.30 33.02	1.40 35.56

Schematics

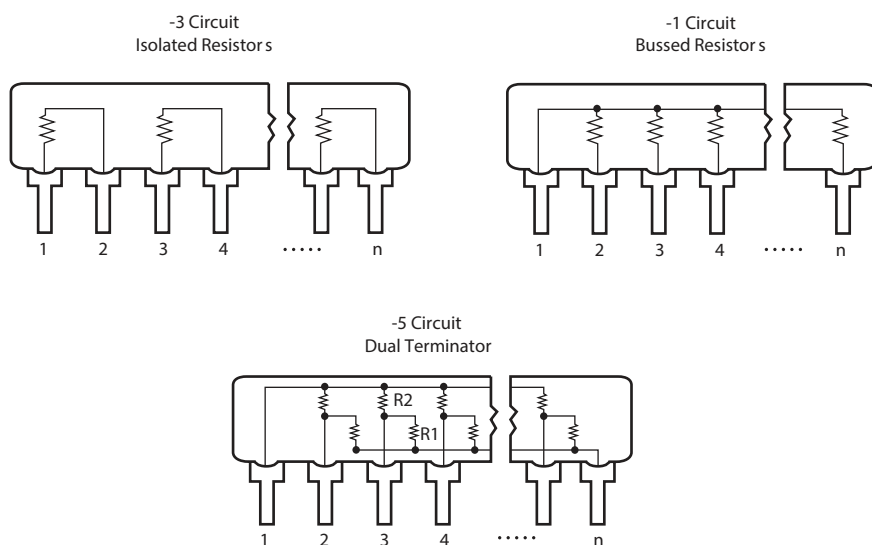

General Note

TT Electronics reserves the right to make changes in product specification without notice or liability. All information is subject to TT Electronics' own data and is considered accurate at time of going to print.

L Series

Typical Part Marking

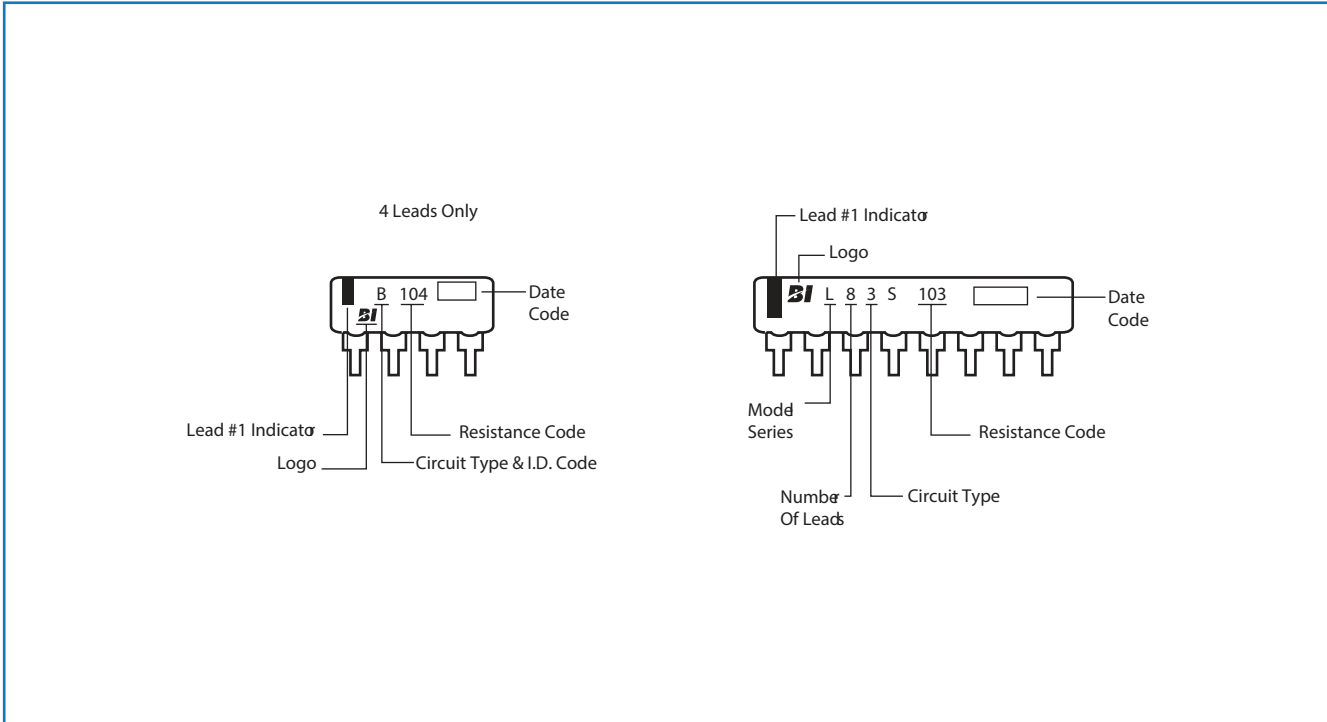

Packaging

Standard:	Bulk:	Quantity	=	4 -10 pins: 200 per bag, 1000 per box 11 -14 pins: 100 per bag, 500 per box
Option:	Tape in Ammo Box (4 - 10 pins only). All Units oriented with lead #1 to the left of direction of feed.			
	Tape:	Width	=	18mm
		Pitch	=	12.7mm
Ammo Box:	Capacity	=	1,000 units per box. 12,000 units per carton	

General Note

TT Electronics reserves the right to make changes in product specification without notice or liability. All information is subject to TT Electronics' own data and is considered accurate at time of going to print.

L Series

Ordering Procedure

Example: L085S331/471FLF (L08, circuit 5, steel leadframe, R1=330 ohms $\pm 1\%$, R2=470 ohms $\pm 1\%$, Pb-free, bulk pack)

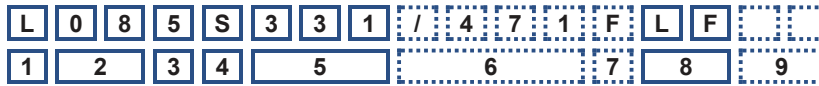

1	2	3	4	5	6	7	8	9
Series	Number of Pins	Circuit Type	Pin Type	R1 Value	R2 Value	Tolerance	Finish	Packing
L	04	1 = Bussed	S = Steel leadframe	2 digits + multiplier	/ 2 digits + multiplier (Circuit type 5 only)	F = $\pm 1\%$	LF = Pb-free	Omit for bulk (standard)
	05	3 = Isolated				Omit for $\pm 2\%$ (standard)		3T = ammo pack, 3 leads only attached to tape
	06	5 = Dual				J = $\pm 5\%$		
	07	Terminator						
	08							
	09							
	10							
	11							
	12							
	13							
	14							

General Note

TT Electronics reserves the right to make changes in product specification without notice or liability. All information is subject to TT Electronics' own data and is considered accurate at time of going to print.