

Constant Current LED Driver

FEATURES

- Very low dropout voltage (100mV @ 1A)
- Accurate current regulation down to dropout voltage
- No external components
- Built-in current DAC
- Output current adjustable with 33.3 mA/steps
- Power-saving shutdown mode of 1 μ A
- Fast turn-on (<50 μ s)
- Timeout function to protect the LED
- Thermal Shutdown protection
- 1A current capability
- RoHS compliant, Lead Free packaging:
Space saving 2mmx3mm 8pin DFN

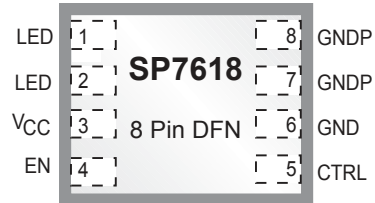

APPLICATIONS

- Next Generation Mobile Phones
- PDA, DSC, MP3 Players
- Handheld Computers
- LCD Display Modules
- Keyboard Backlight

GENERAL DESCRIPTION

The SP7618 is a linear, low-side constant-current driver designed to drive high power LEDs from an input voltage rail. The driver acts as a current source, ensuring constant LED current for a range of input voltages. The SP7618 allows implementing the lowest cost LED driver for a variety of applications. Internal circuitry maintains the preset constant current output for a wide voltage range at the LED input. The LED current can be adjusted up to 1033mA with an external clock applied to the CTRL pin. The built-in thermal protection automatically stops LED current to prevent overheating. A timeout function serves as a failsafe, shutting down the output for currents greater than 266mA after 4 seconds of continuous operation if the enable input is not cycled. The part can be shut down by using the EN pin, or sent into Sleep Mode holding the CTRL pin low for more than 100 μ S.

TYPICAL APPLICATION CIRCUIT

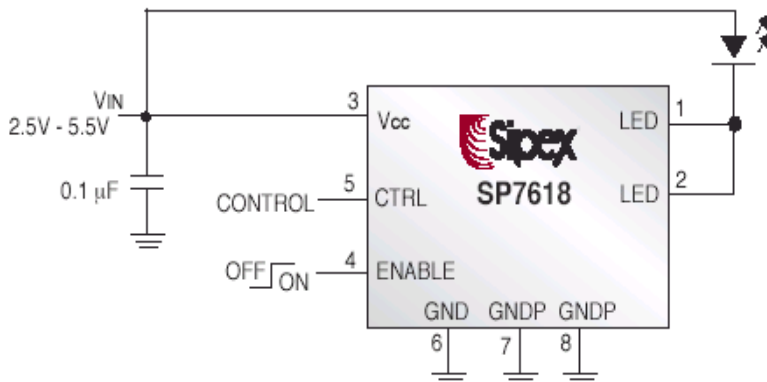

ABSOLUTE MAXIMUM RATINGS

Supply Voltage (Vcc)6.0V
 Input Voltage at any input-0.6V to Vcc +0.5V
 8-pin DFN Package
 Thermal Resistance..... 59°C/W
 Junction Temperature -40 °C to +170 °C*
 Storage Temperature-65°C to +150°C
 Soldering Temperature+240°C**

These are stress ratings only and functional operation of the device at these ratings or any other above those indicated in the operation sections of the specifications below is not implied. Exposure to absolute maximum rating conditions for extended periods of time may affect reliability.

*) Internally limited
 **) Duration 10s maximum

ELECTRICAL CHARACTERISTICS

Ambient temperature $T_A = 25^\circ\text{C}$, $3.0\text{V} < V_{CC} < 5.5\text{V}$, $1.0\text{V} < V_{LED} < 3.0\text{V}$, $100\text{mA} < I_{LED} < 1033\text{A}$. **Bold** denotes specifications which apply over the full operating temperature range, -40°C to $+85^\circ\text{C}$.

PARAMETER		MIN	TYP	MAX	UNITS	CONDITIONS
Vcc Voltage Operating Range ¹		2.5		5.5	V	
Quiescent Current			350	420	μA	I _{LED} = 35mA
Supply Current	Shutdown Mode			1	μA	EN = GND, CTRL = DC
	Sleep Mode			350		EN = Vcc, CTRL = GND
	After Time Duration ²			350		EN = Vcc, CTRL = DC
LED Output Current after	0 pulses on CTRL ³		125		nA	V _{LED} = 1.0V, Vcc = 5.5V
	1 pulse on CTRL ⁴		35		mA	
	3 pulses on CTRL ⁴		102			
	31 pulses on CTRL		1033			
LED Current Accuracy ⁵	-8		8	%		35mA < I _{LED} < 1033 mA
LED Current Line Regulation ⁶			0.1	0.5	%/V	3.0 < Vcc < 5.5V, V _{LED} = 1V
LED Current Load Regulation ⁷			1.5	6	%	1 < V _{LED} < 2.5V, Vcc = 5.5V
LED Current Thermal Regulation			0.01		%/°C	I _{LED} = 100 mA
V _{LED} Dropout Voltage ⁸			50	100	mV	I _{LED} = 100mA @ 25°C
			90	185		I _{LED} = 700mA @ 25°C
			100	210		I _{LED} = 1033mA @ 25°C
Thermal Shutdown Die Temperature			160		°C	I _{LED} = 35mA
Thermal Shutdown Hysteresis			25		°C	
Setup Time after last count ⁹				50	μs	
CTRL input Data Rate			4		MHz	
Wake-up Time from Shutdown				50	μs	EN = LOW to HIGH, CTRL = DC
Turn-off Time into Shutdown				30	μs	EN = HIGH to LOW, CTRL = DC
Turn-off Time into Sleep Mode			125	450	μs	EN = HIGH, CTRL = HIGH to LOW
Time Duration before Sleep Mode		2	4	7	s	I _{LED} > 266 mA, EN = HIGH, CTRL = HIGH
EN and CTRL pin Logic Voltage	LOW			0.4	V	Driver in Shutdown Mode
	HIGH	1.4		Vcc ¹⁰		2.5V ≤ Vcc ≤ 5.5V
Power-on-Reset ¹¹				20	ms	

See notes on next page

Notes (Continued from previous page)

1. V_{CC} must be always higher than LED pin voltage (V_{LED})
2. After 4s at current higher than 266 mA
3. Power MOSFET leakage current
4. Three initial I_{LED} current steps are higher than other 28
5. I_{LED} Variations from specified I_{LED} value
6. I_{LED} Variations per volt V_{CC} change
7. I_{LED} Variations at V_{LED} change from 1 to 2.5V
8. 5% change of I_{LED} compared with I_{LED} value at $V_{LED} = 1V$
9. $I_{LED} = 100$ mA settles 50 μ s later after 3rd pulse
10. Logic HIGH level should never exceed V_{CC} voltage
11. Delay between applying V_{CC} voltage and operating condition

PIN ASSIGNMENTS

Pin #	Pin Name	Pin Function
1 - 2	LED	LED Current Sink. Connect LED cathode to this pin. Voltage at this pin should be above 100 mV to maintain regulation.
3	Vcc	Power Supply Input. Place 1 μ F decoupling capacitor next to this pin.
4	EN	Enable/Shutdown pin used to enable/disable driver and reset DAC: Logic High – enable, Logic Low – disable/reset.
5	CTRL	DAC Serial Input pin is used to control LED current. Positive pulse edges sequentially increase LED current with 33.33mA steps up to 1033 mA (31 steps). When this pin is held LOW for longer than 100 μ s the part enters Sleep Mode.
6	GND	Ground pin for control and bias blocks.
7 - 8	GNDP	Ground pin. LED current flows through this pin to ground.

BLOCK DIAGRAM

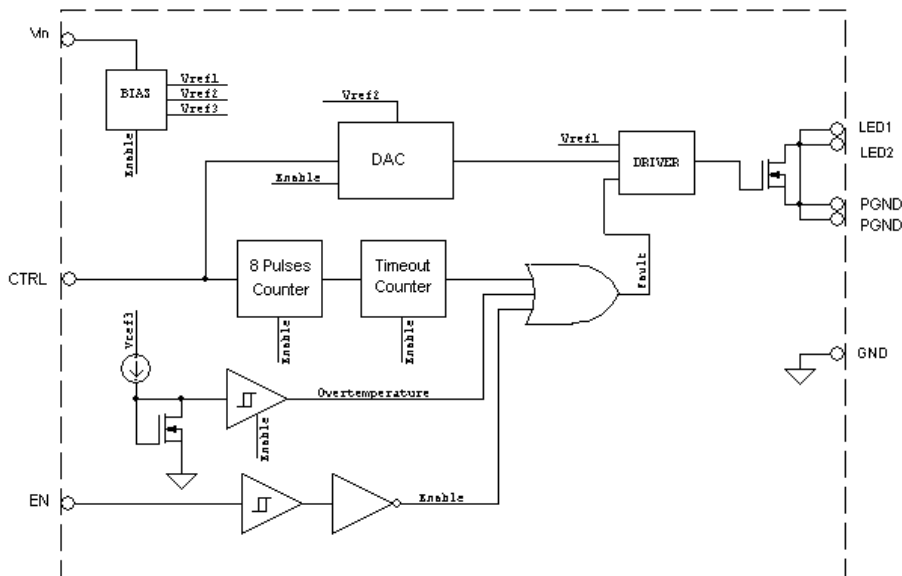

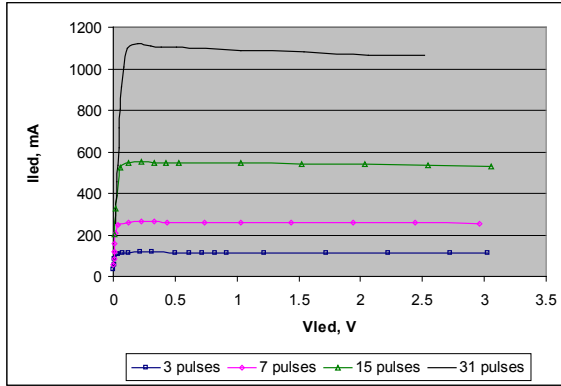

Load regulation at Vcc = 5.5V @ 25°C

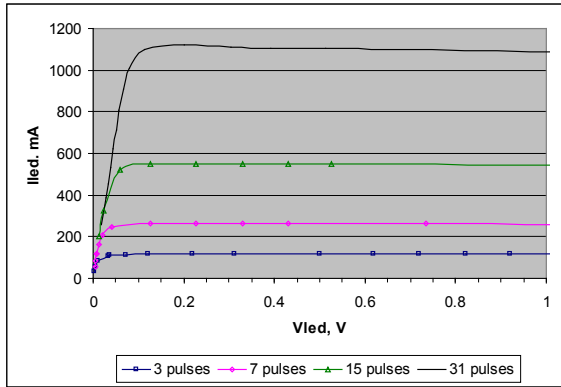

Load regulation at Vcc = 5.5V @ 25°C

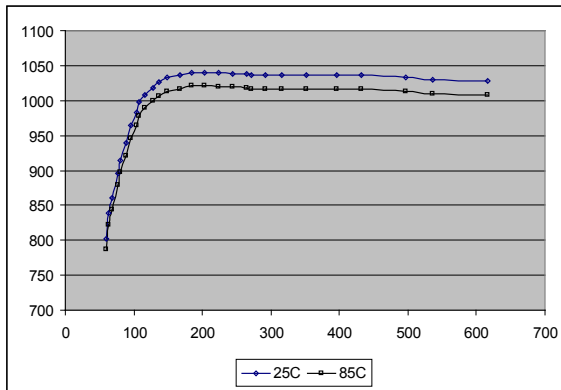

Load regulation vs. temperature at ILED = 1A and Vcc = 5.5V

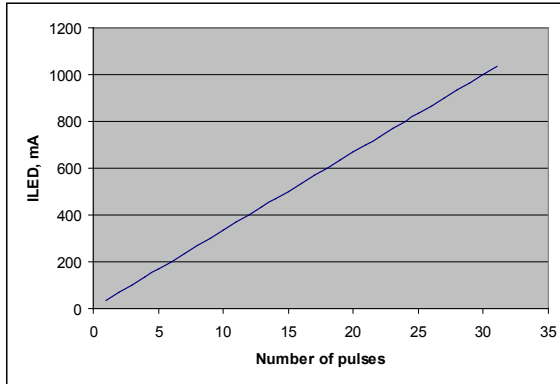

DAC linearity at $V_{LED} = 500mV$

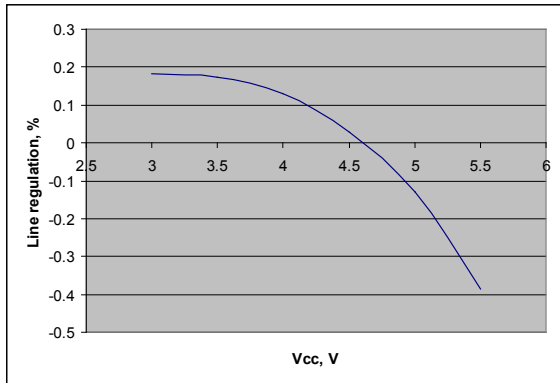

Line regulation at $V_{LED} = 100mA$

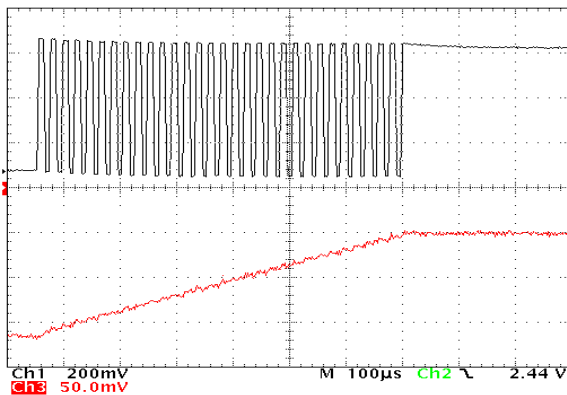

Setup Time at $I_{LED} = 1033A$

Introduction

The SP7618 is a linear low-side, constant-current driver designed to drive high power LEDs from an input voltage rail. The design consists of a regulator reference voltage source, DAC, voltage-to-current converter, thermal shutdown, timeout shutdown, and output driver. The precision reference voltage ensures good performance over voltage and temperature. The built-in thermal protection automatically stops LED current to prevent overheating. A timeout function serves as a failsafe, shutting down the output for currents greater than 266mA after 4 seconds of continuous operation if the enable input is not cycled.

Current Setting DAC

The LED output current is defined by a current control DAC. The input to the DAC is the CTRL pin. The DAC outputs a unit current of 33.33mA with each applied pulse at the CTRL pin. The DAC has 5 bits, so the total number of steps that can be achieved is 2^5 or 32. The initial step of the DAC corresponds to zero, so the maximum current output is 31 times the unit current. Any multiple of the 33.33mA output current can be achieved from 1 to 31 sequentially.

The DAC CTRL input is positive-edge triggered and may be either at high or low logic state when the part is powered up. The ENABLE pin logic HIGH level may be applied with V_{cc} voltage.

The CTRL input allows an increase in LED current only. If a lower I_{LED} current value is required, the device should be sent into shutdown mode (EN =HIGH to LOW/LOW to HIGH) and a new pulse sequence should be applied to the CTRL pin.

If the pulse number exceeds 31, all other pulses are ignored and 1033 mA current is set.

The SP7618 can be placed into Sleep Mode by applying a logic LOW on the CTRL pin for longer than 100 μ s after any pulse sequence. In the Sleep Mode, the driver is disabled and I_{LED} current is zero, but blocks associated with the DAC remain active, and I_{cc} Sleep Mode Current is always higher than I_{cc} current in Shutdown Mode. This function is used to output the I_{LED} current for a specified duration.

If the I_{LED} current exceeds 266 mA (8 pulses) the maximum Time Duration is 4s. After that, the device is automatically sent into Sleep Mode. This function is intended to protect the LED if, for example, the device was left on in a high current condition for a long period of time.

Applying a new pulse sequence to the CTRL pin at Sleep Mode will wake up the device but increase the I_{LED} current at 33.3mA multiplied by the number of pulses. To return the device to the previous or lower I_{LED} current value, use Shutdown (EN =HIGH to LOW/LOW to HIGH) and apply a new pulse sequence to the CTRL pin.

The current control DAC accepts clock rates up to 4MHz. The code for the DAC loads while the output driver takes 50 μ s to respond. This implies that the LED output current will reach its final value 50 μ s after the final pulse is applied to the CTRL pin.

Output Driver

The SP7618 features a low-side regulated output current driver. A large MOSFET device is connected between the LED and GNDP pins. The MOSFET drain is connected to the LED pins and the MOSFET source is connected to the GNDP pins. There are two pins on each terminal of the MOSFET in order to minimize power dissipation inside the package. Even though there are two LED and GNDP pins, there is actually only one output intended to drive one LED.

The light emitting diode connects from VCC to the LED pins. The I_{LED} current regulation is guaranteed at dropout at the LED pins to be less than 100mV. The output current is regulated to within five percent of nominal value even if the voltage between the LED and GNDP pins varies over a wide range. The nominal output is guaranteed within $\pm 8\%$ of the defined current.

Thermal Protection

The SP7618 has built-in thermal protection. An internal P-N junction is compared to the internal temperature compensated reference. When the P-N junction reaches a temperature specific voltage, it trips a comparator which shuts down the driver stage of the part placing the device into sleep mode while DAC circuit remains active. The shutdown temperature is defined to be 160°C.

The comparator circuit has built-in hysteresis corresponding to 25°C. The output stage will resume operation and start sinking the current that was defined prior to shutdown when

the internal temperature drops by 25°C. If the part remains in a high ambient temperature environment or if a high power dissipation condition exists, the output stage will cycle on and off to maintain a preset internal junction temperature to avoid catastrophic damage. In that case, the LED will appear to be blinking. Lower the LED voltage to avoid excess power dissipation in the IC.

Shutdown

The SP7618 has a low current shutdown function. In shutdown mode, the part draws less than 0.1 μ A current maximum. The part can be placed into shutdown using the EN pin.

ENABLE and CTRL pins cannot be tri-stated or left floating. There are no predefined internal states, so leaving these pins open will cause the part to operate incorrectly.

Timeout

A Time Duration Before Shutdown feature acts as a failsafe to protect the LED from long ON times. The nominal timeout is defined as 4 seconds.

Power-on-Reset

This function is used to set DAC and Time Duration counters into their initial state after power up. No signal applied to the CTRL pin can be accepted during this time, even if the input voltage is applied simultaneously to Vcc and ENABLE pins.

BOARD LAYOUT AND GROUNDING

To obtain the best performance from the SP7618, a printed circuit board with ground plane is required. High quality, low series resistance ceramic $1\mu\text{F}$ bypass capacitors should be used at the V_{CC} pin (pin 3). These capacitors must be located as close to pins 3 – 6 as possible. The traces connecting the pins and the bypassing capacitors must be kept short and should be made as wide as possible. Pins 1 – 2 are connected together internally but we recommend connecting the

LED cathode to both pins to avoid additional power losses at high current. Pins 6, 7 and 8 should be connected to the ground plane. Board layout should prevent high LED ground current from flowing through signal ground connected to pin 6. This pin is a separate ground for the reference and logic sections of the SP7618. The quiescent current for the part flows into the V_{CC} pin and out of the GND pin. This current is proportional to the I_{LED} current divided by approximately 1500.

TIMING DIAGRAM

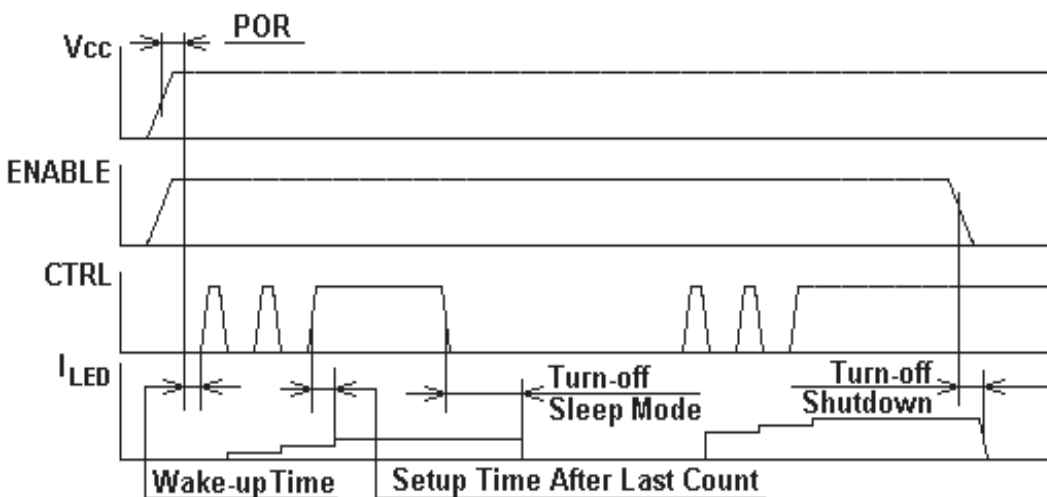

TOP VIEW

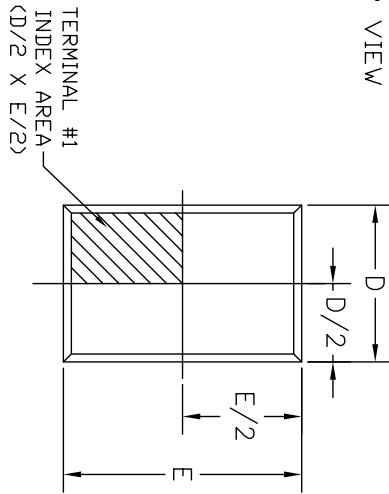

BOTTOM VIEW

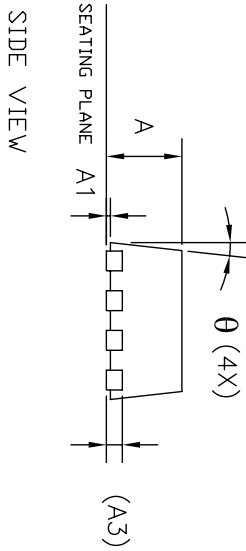
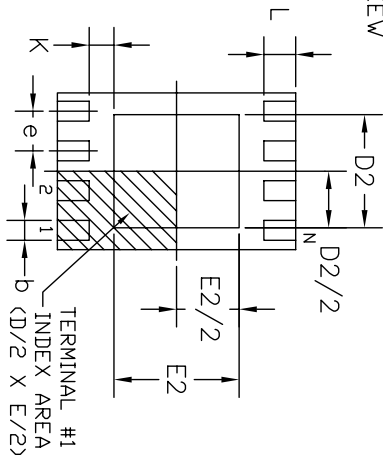

8LD 2x3 DFN JEDEC MO-229 Variation VCED-2		DIMENSIONS IN MM (Control Unit)		DIMENSIONS IN INCH (Reference Unit)		
SYMBOLS	MIN	NOM	MAX	MIN	NOM	MAX
A	0.80	0.90	1.00	0.032	0.036	0.039
A1	0.00	0.02	0.05	0.000	0.001	0.002
A3	0.20 REF			0.008 REF		
b	0.18	0.25	0.30	0.007	0.010	0.012
D	2.00 BSC			0.079 BSC		
D2	1.50	—	1.75	0.059	—	0.069
E	3.00 BSC			0.118 BSC		
E2	1.60	—	1.90	0.063	—	0.075
e	0.50 BSC			0.020 BSC		
L	0.30	0.40	0.50	0.012	0.016	0.020
K	0.20	—	—	0.008	—	—
theta	0°	—	14°	0°	—	14°
N	8			8		
ND	4			4		

REVISION HISTORY			
REV	DESCRIPTION	DATE	APP'D
A	DRAWING ORIENTATION	09/18/05	JL
B	MODIFY DRAWING FORMAT	07/17/06	JL

SIPEX CORPORATION

8 PIN 2x3 DFN PACKAGE OUTLINE

Packaging Approval: **SIPEX CORPORATION**

By: JL Date: 07/17/06 Drawing No: 8-PIN 2x3 DFN Revision: B Sheet: 1 OF 1

Part Number	Operating Temperature Range	Package Type
SP7618ER-L.....	-40°C to +85°C	Lead Free 8 Pin DFN (2mm x 3mm)
SP7618ER-L/TR	-40°C to +85°C	Lead Free 8Pin DFN (2mm x 3mm)

/TR = Tape and Reel

Pack quantity is 3,000 for DFN.



Sipex Corporation

**Headquarters and
Sales Office**

233 South Hillview Drive
Milpitas, CA 95035
TEL: (408) 934-7500
FAX: (408) 935-7600

Sipex Corporation reserves the right to make changes to any products described herein. Sipex does not assume any liability arising out of the application or use of any product or circuit described herein; neither does it convey any license under its patent rights nor the rights of others.