

VN Series

Pressure Sensor Family for Ventilator Applications

- Family of inspiratory, expiratory, flow, inlet & barometric pressure sensors
- Highly integrated sensors with ADC and DSP
- Output Data Rate up to 1.09kHz
- 24-bit resolution (each selected range)
- Pure O₂ compatible
- Up to 8 Selectable Pressure Ranges per Device
- Exceptional Zero Stability
- Selectable Bandwidth Filter from 1.0Hz to 500Hz
- Total Error Band less than 0.15% FSS
- Very High Accuracy $\pm 0.05\%$ of Selected Range
- Long Term Stability $\pm 0.10\%$ FSS
- Sensors for flow available in high and extreme resolution
- Inlet & Barometric pressure sensors include silicone gel protection
- Temperature Compensated 0°C to 50°C
- Fully Integrated Compensation Math
- Standard I²C and SPI Interface

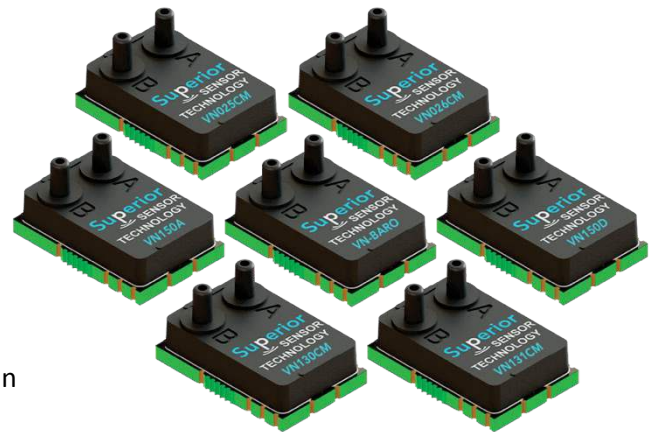

Product Summary

Based on Superior’s NimbleSense™ architecture, the VN Series is a comprehensive set of pressure sensors for ventilator and high flow oxygen devices. The family of products includes sensors for measuring inlet (wall and tank), flow, inspiratory, expiratory and barometric pressures. The VN Series utilizes Multi-Range™ technology to create the industry’s widest dynamic range, eliminating the need for fine tuning or additional calibration.

The VN Series combines an advanced piezoresistive sensing element with integrated amplification, ADC, DSP and a digital interface. Advanced digital processing enables new functionality thus simplifying system development, adding manufacturing ease and increasing reliability.

With optional advanced digital filtering customization and a 3-mode pressure switch, the VN Series is more than a pressure sensor – it is a pressure sensing sub-system.

Finally, the VN Series eliminates the need for the ventilator to oversample sensor outputs, as the sensor oversamples at 12kHz and includes internal bandwidth filters to provide a clean > 1kHz update rate.

Constructed with a high reliability plastic enclosure, the VN Series provides the ideal combination of very high performance and reliability while ensuring customers have a high volume, cost effective solution optimized for ventilators and high flow oxygen devices.

Application	VN025CM	VN026CM	VN130CM	VN131CM	VN150D	VN150A	VN-BARO
Pressure Ranges	± 5 to ± 25 cmH ₂ O	± 2.5 to ± 25 cmH ₂ O	± 80 to ± 130 cmH ₂ O	± 60 to ± 130 cmH ₂ O	± 80 to ± 150 psi	80 to 150 psia	350 to 1100 mbar
Silicone gel protection			☑	☑	☑	☑	☑
Inlet Pressure					☑	☑	
Inspiratory Pressure			☑☑	☑			
Expiratory Pressure			☑☑	☑			
Expiratory Flow	☑	☑☑					
Flow (Blower based)	☑	☑☑					
Flow (Wall & Tank based)			☑	☑☑			
Volumetric to Mass Flow							☑

Table of Contents

- 1 Maximum Ratings 2
- 2 Suggested Operating Conditions 2
- 3 Environmental 2
- 4 Equivalent Circuit 2
- 5 Feature List 3
 - 5.1 Low Pressure (cmH2O Ranges) 3
 - 5.2 Middle Pressure (psi Ranges) 3
 - 5.3 Barometric Pressure (mbar Ranges) 3
- 6 Performance Characteristics 4
 - 6.1 Low Pressure (cmH2O Ranges) 4
 - 6.2 Middle Pressure (psi Ranges) 4
 - 6.3 Barometric Pressure (mbar Ranges) 5
- 7 Electrical Characteristics 5
 - 7.1 Supply Characteristics 5
 - 7.2 Reset Characteristics 6
 - 7.3 DAV Characteristics 6
 - 7.4 I²C Characteristics 6
 - 7.5 SPI Characteristics 7
- 8 Materials 7
 - 8.1 Wetted Materials 7
 - 8.2 Material Compliance 7
- 9 System Overview 8
- 10 Interface 9
 - 10.1 Reset 9
 - 10.2 Communication Interface Selection 9
 - 10.3 SPI Interface 9
 - 10.4 I²C Interface 10
 - 10.4.1 I²C Address 10
 - 10.4.2 I²C Communications Model 10
 - 10.4.3 I²C Clock Stretching 11
 - 10.4.4 I²C Bus Compatibility 11
 - 10.5 Extended Data Acquisition 12
 - 10.5.1 Available Extended Data 12
 - 10.5.2 SPI Extended Data Read 12
 - 10.5.3 I²C Extended Data Read 12
 - 10.6 Control Registers 13
 - 10.6.1 Mode Control Register 13
 - 10.6.2 Rate Control Register 14
 - 10.7 Computing Pressure 14
- 11 Mechanical and Manufacturing 15
 - 11.1 Package Dimensions 15
 - 11.2 Suggested Pad Layout 15
 - 11.3 Pinout 16
 - 11.4 Reflow Soldering and Handling Conditions 16
 - 11.5 Pick and Place Pick-up Zone 16
 - 11.6 Packaging Options 17
 - 11.6.1 Tray Packaging 17
 - 11.6.2 Tape and Reel 18
 - 11.7 Part Identification 18
- 12 Packaging Labeling 19
- 13 Ordering Information 19
- 14 Revisions 20
- 15 Warranty 20

1 Maximum Ratings

Parameter	Sym	Min	Max	Units
Supply Voltage	V _{DDM}	Gnd-0.3	4.0	V
Voltage on I/O Pins	V _{DD} > 3.3V	Gnd-0.3	5.8	V
	V _{DD} ≤ 3.3V	Gnd-0.3	V _{DD} +2.5	V
I/O Current	I _{IOM}	-25	25	mA

2 Suggested Operating Conditions

Parameter	Sym	Min	Max	Units
Supply Voltage	V _{DDOP}	2.8	3.5	V
Temperature	T _A	0	50	°C

3 Environmental

Parameter	Sym	Min	Max	Units
Temperature Range	T _{COMP}	0	50	°C
	T _{OP}	-20	85	°C
	T _{STG}	-40	85	°C
Humidity (Non-condensing)	RH _{OP}	0	95	% RH
Vibration (10Hz-2kHz)	G _{VIBE}	-	15	g
Shock (6 ms)	G _{SHOCK}	-	100	g
Life	CY _{LIFE}	100M	-	Pressure Cycles

4 Equivalent Circuit

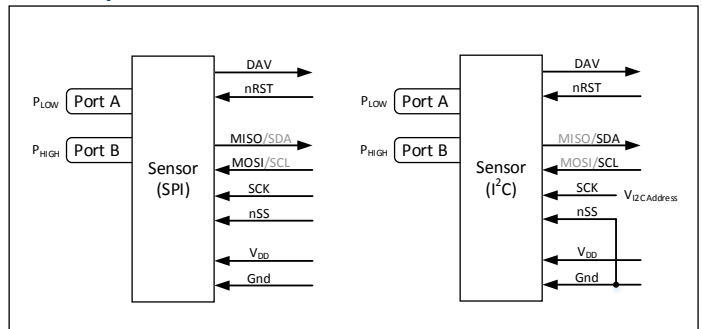

VN Series

Ventilator Pressure Sensors

5 Feature List

5.1 Inspiratory, Expiratory and Flow Pressure (cmH2O Ranges)

Parameter	Sym	VN025CM	VN026CM	VN130CM	VN131CM	Units	Notes
Number of FS Pressure Ranges	P _{NUM}	6	7	6	8	Each	
Specified FS Range Extents	P _{EXT}	±5.0 to ±25	±2.5 to ±25	±80 to ±130	±60 to ±130	cmH ₂ O	
Number of BW Filter Corners	BW _{NUM}	8				Each	
BW Corner Frequency Extents	f _{BWEXT}	20 to 500				Hz	
Common Mode Pressure	P _{CM}	1,500		2,000		cmH ₂ O	1
Proof Pressure	P _{PROOF}	100		1,000		cmH ₂ O	2
Burst Pressure	P _{BURST}	300		3,000		cmH ₂ O	3

5.2 Inlet Pressure (psi Ranges)

Parameter	Sym	VN150D (psid)	VN150A (psia)	Units	Notes
Number of FS Pressure Ranges	P _{NUM}	6	1	Each	
Specified FS Range Extents	P _{EXT}	±80 to ±150	80 to 150	psi(a)	
Number of BW Filter Corners	BW _{NUM}	8	8	Each	
BW Corner Frequency Extents	f _{BWEXT}	1.0 to 300	1.0 to 300	Hz	
Common Mode Pressure	P _{CM}	150	150	psi(a)	1
Proof Pressure	P _{PROOF}	250	250	psi(a)	2
Burst Pressure	P _{BURST}	300	300	psi(a)	3

5.3 Barometric Pressure (mbar Range)

Parameter	Sym	VN-BARO (psid)	Units	Notes
Number of FS Pressure Ranges	P _{NUM}	6	Each	
Specified FS Range Extents	P _{EXT}	350-1100 to 800-1100	mbar	
Number of BW Filter Corners	BW _{NUM}	8	Each	
BW Corner Frequency Extents	f _{BWEXT}	1.0 to 300	Hz	
Proof Pressure	P _{PROOF}	35	mbar	2
Burst Pressure	P _{BURST}	40	mbar	3

- 1) Pressure applied to both ports simultaneously without incurring part damage.
- 2) Pressure at which the sensor will not suffer permanent damage.
- 3) Pressure if exceeded could cause permanent damage to the sensor.

VN Series

Ventilator Pressure Sensors

6 Performance Characteristics

Note: Unless otherwise specified, characteristics specified with $V_{DD} = 3.3V$, $T_A = 25C$

6.1 Inspiratory, Expiratory and Flow Pressure (cmH₂O Ranges)

Parameter	Sym	VN025CM/VN130CM			VN026CM			VN131CM			Units	Notes
		Min	Typ	Max	Min	Typ	Max	Min	Typ	Max		
Accuracy	P _{ACC}	-	0.05	0.20	-	0.05	0.20	-	0.05	0.20	% RNG	1
Total Error Band	TEB	-	0.15	0.30	-	0.10	0.25	-	0.10	0.25	% FSS	3
TEB After AZ	TEB _{AZ}	-	0.05	0.20	-	0.05	0.15	-	0.05	0.15	% FSS	7
Long Term Stability	LTS	-	0.10	0.25	-	0.05	0.15	-	0.05	0.15	% FSS/Yr	2
Thermal Hysteresis	T _{HYS}	-	0.05	-	-	0.03	-	-	0.03	-	% FSS	
Pressure Hysteresis	P _{HYS}	-	0.05	-	-	0.05	-	-	0.05	-	% RNG	1
Position Sensitivity	P _{PS}	-	0.03	-	-	0.003	-	-	0.003	-	cmH ₂ O	
Supply Rejection	P _{SR}	-	0.0005	-	-	0.0005	-	-	0.0005	-	% FSS/mV	
Output Resolution	RES _{OUT}	-	24	-	-	24	-	-	24	-	bit	4
Effective Resolution	RES _{EFF}	-	16	-	-	18.5	-	-	18.0	-	Bit _{RMS}	5
Data Update Rate	f _{UPDATE}	1.05	1.09	1.12	1.05	1.09	1.12	1.05	1.09	1.12	kHz	6

6.2 Inlet Pressure (psi Ranges)

Parameter	Sym	VN150D			VN150A			Units	Notes
		Min	Typ	Max	Min	Typ	Max		
Accuracy	P _{ACC}	-	0.05	0.20	-	0.05	0.20	% RNG	1
Total Error Band	TEB	-	0.15	0.30	-	0.25	0.40	% FSS	3
TEB After AZ	TEB _{AZ}	-	0.05	0.20	-	0.05	0.20	% FSS	7
Long Term Stability	LTS	-	0.10	0.25	-	0.15	0.35	% FSS/Yr	2
Thermal Hysteresis	T _{HYS}	-	0.05	-	-	0.10	-	% FSS	
Pressure Hysteresis	P _{HYS}	-	0.05	-	-	0.05	-	% RNG	1
Supply Rejection	P _{SR}	-	0.0005	-	-	0.0007	-	% FSS/mV	
Output Resolution	RES _{OUT}	-	24	-	-	24	-	bit	4
Effective Resolution	RES _{EFF}	-	17.2	-	-	16.2	-	Bit _{RMS}	5
Data Update Rate	f _{UPDATE}	1.05	1.09	1.12	1.05	1.09	1.12	kHz	6

VN Series

Ventilator Pressure Sensors

6.3 Barometric Pressure (mbar Range)

Parameter	Sym	VN-BARO			Units	Notes
		Min	Typ	Max		
Accuracy	P _{ACC}	-	0.05	0.20	% FS	
Total Error Band	TEB	-	0.20	0.50	% FS	3
Long Term Stability	LTS	-	0.10	0.25	% FS/Yr	2
Thermal Hysteresis	T _{HYS}	-	0.10	-	% FS	
Pressure Hysteresis	P _{HYS}	-	0.05	-	% FS	1
Supply Rejection	P _{SR}	-	0.0005	-	% FS/mV	
Output Resolution	RES _{OUT}	-	24	-	bit	4
Effective Resolution	RES _{EFF}	-	16.2	-	Bit _{RMS}	5
Data Update Rate	f _{UPDATE}	1.05	1.09	1.12	kHz	6

- 1) Percentage of selected range.
- 2) YR1 is the first year. The most significant drift occurs during the first year and is lessened for each subsequent year. For each subsequent year, use 25% of the prior years' drift figure to estimate the drift for that year.
- 3) Includes errors of offset, span, hysteresis and thermal effects.
- 4) Each selected range has the specified resolution
- 5) Effective Resolution is stated for f_{BW} set to 100 Hz.
- 6) The internal update rate is fixed and does not change with range or filter settings. Sampling at lower data rates are possible, provided the Nyquist frequency is observed. It is suggested to sample at least 3x the set f_{BW} frequency.
- 7) Total error band within 24 hours of a sensor auto-zero. Includes all error components of TEB.

7 Electrical Characteristics

7.1 Supply Characteristics

Parameter	Sym	VN026CM/VN131CM			VN025CM/VN130CM/ VN-BARO/VN150D/VN150A			Units	Notes
		Min	Typ	Max	Min	Typ	Max		
Supply Current	I _{DD}	-	9.0	11	-	5.5	6.5	mA	
Supply Capacitance	C _{DD}	-	10	-	-	10	-	uF	1

- 1) Supply capacitance is provided within the part however it is recommended to include a 0.1 uF decoupling cap near the supply pads.

VN Series

Ventilator Pressure Sensors

7.2 Reset Characteristics

Parameter	Sym	Condition	All VN Series Parts			Units	Notes
			Min	Typ	Max		
Power-On Reset Threshold	V_{PORR}	Rising Voltage on V_{DD}	-	1.4	-	V	
	V_{PORF}	Falling Voltage on V_{DD}	0.75	-	1.36	V	
Interface Detect Delay	t_{IOD}	From POR or External Reset	-	-	40	ms	
First Response Settling Time	t_{FRD}	From POR or External Reset	-	-	55	ms	1
External Reset Low	t_{RSTL}		15	-	-	us	
Input High Voltage	V_{IH}		$V_{DD}-0.6$	-	-		2
Input Low Voltage	V_{IL}		-	-	0.6		2
Internal Pull-Up Current	I_{PU}	$V_{IN} = 0V$	-	-10	-30	uA	2
Input Capacitance	C_{IN}		-	7	-	pF	2

1) The filter settling time to ensure the first reading is completely settled.

2) Input nRST

7.3 DAV Characteristics

Parameter	Sym	Condition	All VN Series Parts			Units	Notes
			Min	Typ	Max		
Output High Voltage	V_{OH}	$I_o = -3 \text{ mA}$	$V_{DD}-0.7$	-	-	V	
Output Low Voltage	V_{OL}	$I_o = 8 \text{ mA}$	-	-	0.6	V	

7.4 I²C Characteristics

Parameter	Sym	Condition	All VN Series Parts			Units	Notes
			Min	Typ	Max		
SCL Clock Frequency	f_{SCL}		100	-	400	kHz	
Clock Stretch Time	t_{CKSTR}		-	10	25	us	
Input High Voltage	V_{IH}		$V_{DD}-0.6$	-	-		
Input Low Voltage	V_{IL}		-	-	0.6		
Output Low Voltage	V_{OL}	$I_o = 8 \text{ mA}$	-	-	0.6	V	
Input Capacitance	C_{IO}		-	7	-	pF	

VN Series

Ventilator Pressure Sensors

7.5 SPI Characteristics

Parameter	Sym	Condition	All VN Series Parts			Units	Notes
			Min	Typ	Max		
Output High Voltage	V _{OH}	I _O = -3 mA	V _{DD} -0.7	-	-	V	1
Output Low Voltage	V _{OL}	I _O = 8 mA	-	-	0.6	V	1
Input High Voltage	V _{IH}		V _{DD} -0.6	-	-		2, 3
Input Low Voltage	V _{IL}		-	-	0.6		2, 3
Internal Pull-Up Current	I _{PU}	V _{IN} = 0V	-	-10	-30	uA	2, 3
Time nSS to First SCK Edge	t _{SC}		30	-	-	us	
Clock Cycle Time	t _{CC}		1	-	-	us	
Byte to Byte Cycle Time	t _{BC}		25	-	-	us	
Time Last Clock to nSS High	t _{CN}		5	-	-	us	
Cycle Time nSS	t _{CS}		5	-	-	us	
Input Capacitance	C _{IN}		-	7	-	pF	2

- 1) Output MOSI
- 2) Inputs MISO, SCK, nSS
- 3) Inputs are 5V compliant.

8 Materials

8.1 Wetted Materials

Parameter	Sym	VN026CM/VN131CM		VN025CM/VN130CM/ VN-BARO/VN150D/VN150A		Units	Notes
		P _A	P _B	P _A	P _B		
Wetted Materials	MAT _{WET}	Epoxy Nylon RTV Silicon Gold Aluminum	Epoxy Nylon RTV Silicon Gold Aluminum	Epoxy Nylon RTV Silicon	Epoxy Nylon RTV Silicon Gold Aluminum		

8.2 Material Compliance

Parameter	Sym	All VN Series Parts	Units	Notes
RoHS	REG _{RoHS}	RoHS Compliant		
REACH	REG _{REACH}	REACH Compliant		

VN Series

Ventilator Pressure Sensors

9 System Overview

The VN Series pressure sensor is a fully integrated pressure acquisition system in a sensor module. The acquisition system includes anti-alias filters, data acquisition, sensor compensation, bandwidth limiting and I/O functions. Refer to the figure below for the VN Series block diagram.

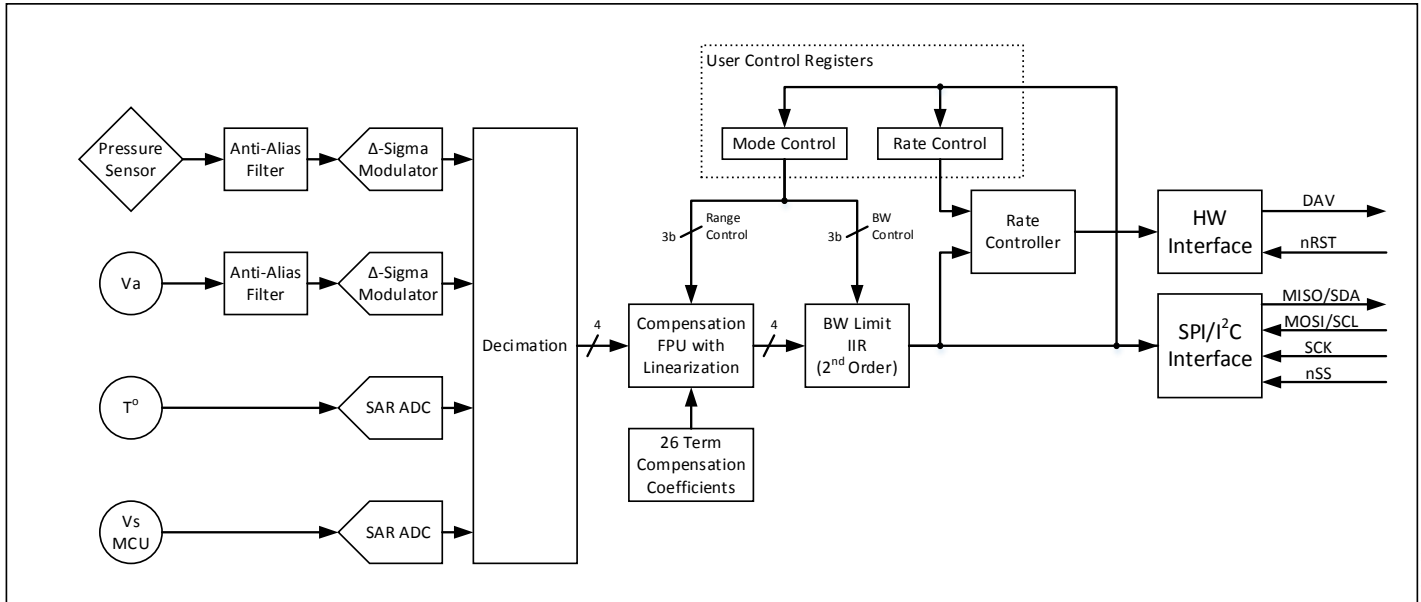

There are also two user controlled registers that tune the sensor to the specific user requirements. The first register is the Mode Control register that determines the output pressure range and the corner frequency of the bandwidth limiting filter.

The second register is the Rate Control register which controls the rate at which the Data Available (DAV) pin is asserted. The internal sensor data update rate of 1.09 kHz is used to generate a rising edge on the DAV line signaling the host there is a new pressure reading that is available. The rate control register is used to divide the update frequency by "n" to slow the DAV indication rate to the host. For example, a divide by one causes the DAV to be set at each internal update. A divide by two will cause a DAV signal to be asserted every second internal update etc. The rate control register maximum value is 255 so using this value will assert the DAV once for every 255 internal updates.

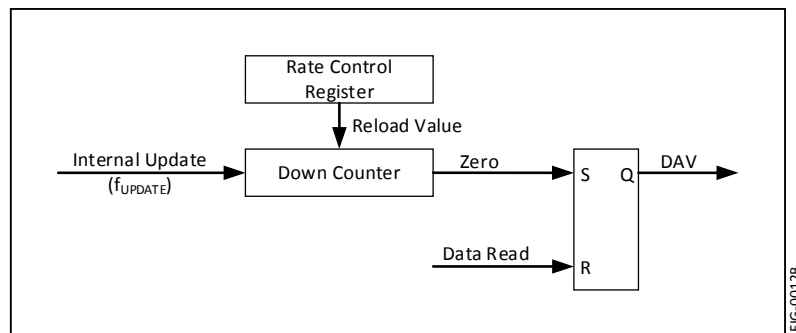

10 Interface

10.1 Reset

Reset timing is shown in the diagram below.

The communications method (SPI or I²C) is established during the time just after reset. During this time (t_{IOD}), no communications should take place.

Also, the internal filters are settling during the time t_{FRD} and data acquired during this time may not be fully settled.

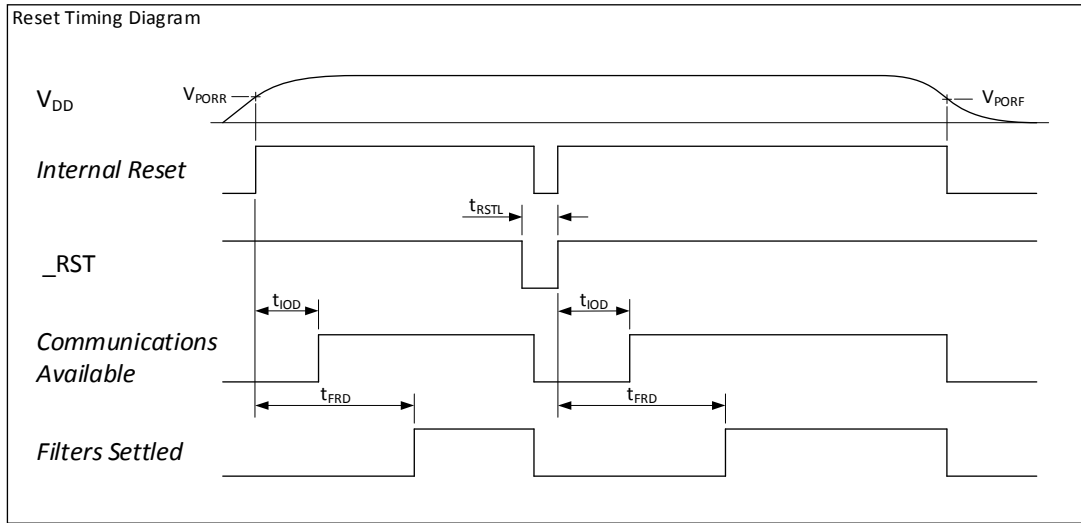

10.2 Communication Interface Selection

The communications interface is selected by interrogating the nSS pin after the internal power on reset delay. If nSS is high, the SPI interface will be selected otherwise (if low) the I²C interface will be selected. Grounding the nSS pin is an acceptable method for selecting the I²C interface. NOTE: The I²C interface supports 10 interface addresses. Refer to section 10.4.1 for the details on I²C address selection.

For both the SPI and I²C interface, all data transfers are MSB first (reading and writing).

10.3 SPI Interface

The SPI interface uses spi mode 1. That is clock idle low with data read on the second (falling) clock edge. Refer to the figure below for specific timing requirements. Note: A two byte transfer is shown for timing purpose only. This is extensible as determined by the desired data to be retrieved from the sensor.

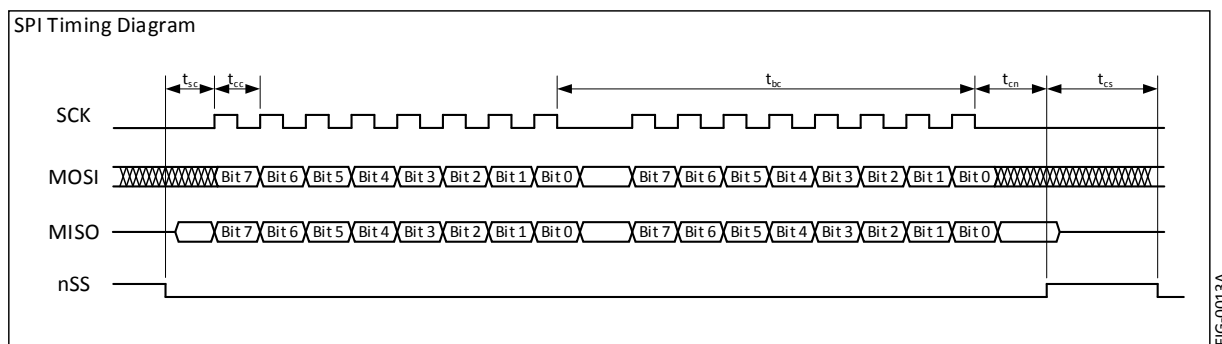

VN Series

Ventilator Pressure Sensors

Each communication cycle consists of master sending the Mode and Rate data to be placed into the sensor Mode Register and Rate Registers respectively. Simultaneously, the sensor sends the pressure data for the master to receive. Refer to the figure below for the data communication model of the VN Series sensor.

The requirement to send the Mode and Rate bytes on each data read cycle is intentional. The purpose is to force the master to send specific data for each communication and prevent inadvertent data from being sent to the sensor. Since a SPI interface will generally re-circulate data through its shift register, the intention is to prevent the pressure output from the sensor from being re-circulated back to the sensor and potentially causing unintended corruption of the internal mode register.

Any number of bytes can be transferred using this model. It is only required that the first two bytes of the transfer include the Mode and Rate bytes being sent via the MOSI line. Subsequent bytes (byte 3, 4 etc) do not require specific data on the MOSI and will be ignored.

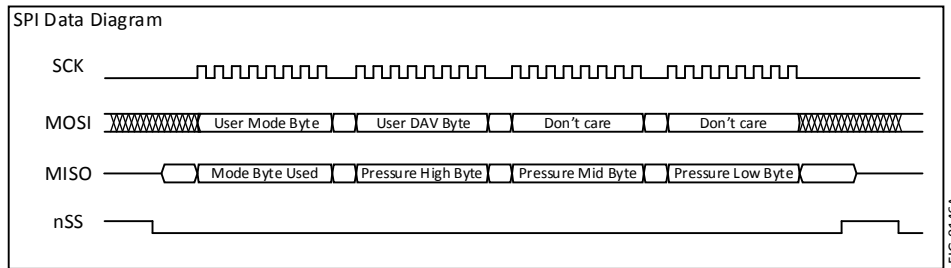

FIG-0146A

10.4 I²C Interface

The VN Series is compatible with the I²C protocol. For detailed information regarding the I²C protocol, please refer to the Philips I²C Bus Specification, Version 2.

10.4.1 I²C Address

I2C Address Selection Table			
R1 (kΩ)	R2 (kΩ)	Address (decimal)	Address (hex)
120	5.6	49	0x31
120	12	48	0x30
120	27	47	0x2F
120	51	46	0x2E
120	100	45	0x2D
56	100	44	0x2C
30	100	43	0x2B
15	100	42	0x2A
5.6	100	41	0x29
0	NoPop	40	0x28

The I²C address is set to 0x28 by grounding the SCK line. Other I²C addresses can be established by applying a voltage to the SCK line by use of a resistor divider across the sensor supply voltage. The suggested resistor values and the respective I²C address are shown in the table to the left.

Note: R1 is the lower resistor of the divider where R2 is the upper resistor of the divider.

10.4.2 I²C Communications Model

The sensor is configured as a slave device and as such, the communicating host must be configured as a master. There are two types of possible data transfers, data transfers from the master transmitter to an addressed sensor (WRITE), and data transfers from an addressed sensor to a master receiver (READ). The master device initiates both types of data transfers and provides the serial clock pulses on SCL.

VN Series

Ventilator Pressure Sensors

The communications model for I²C is similar to that of SPI however, since I²C is a half-duplex protocol, the transfer of information to and from the sensor is separated into two individual communications. This is in contrast to the SPI interface where the transmitted and received data occurs simultaneously to and from the host. Refer to the figure to the right for the data communication model for the VN Series sensors.

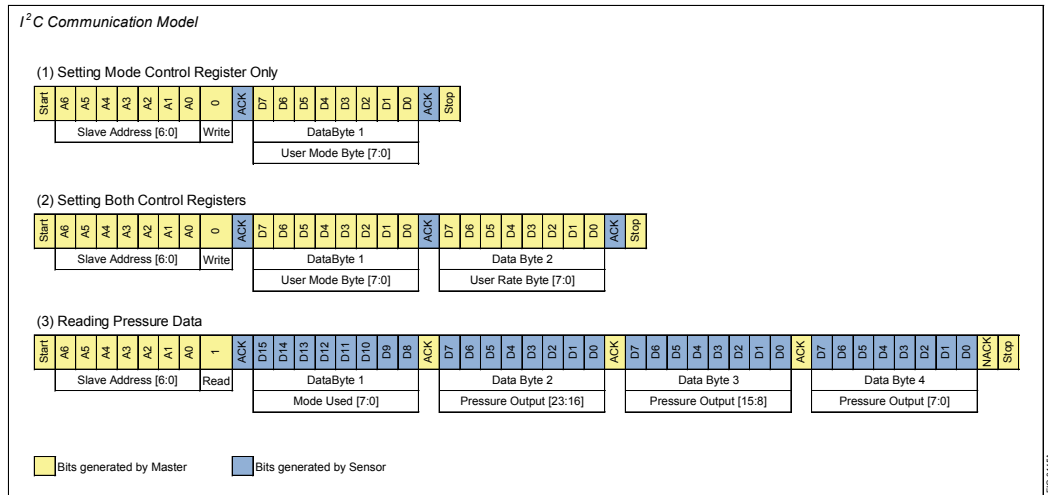

10.4.3 I²C Clock Stretching

The figure to the right illustrates the I²C clock stretching by the sensor. At times, the sensor requires additional time to respond to the host and utilizes the clock stretching feature of the I²C protocol. This is accomplished by holding the SCL low after the ACK cycle of a data transfer. Refer to Section 7.4 for the clock stretching timing. Note, the maximum clock stretch time will generally only occur once during the three ACK cycles of a two byte transfer. That is, the balance of ACK's during a multi-byte transfer will generally include the typical clock stretching time.

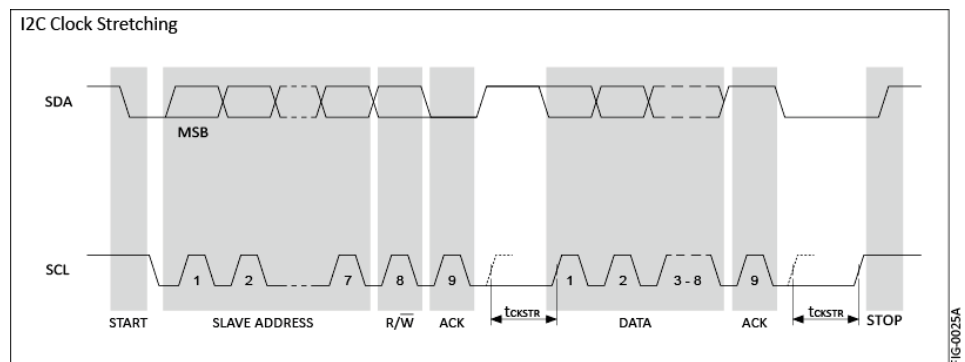

10.4.4 I²C Bus Compatibility

The I²C specification allows any recessive voltage between 3.0 and 5.0 V. Different devices on the bus may operate at different voltage levels. However, the maximum voltage on any port pin must conform to the electrical characteristics specifications (See section 1). The bi-directional SCL (serial clock) and SDA (serial data) lines must be connected to a positive power supply voltage through a pull-up resistor or similar circuit. Every device connected to the bus must have an open-drain or open-collector output for both the SCL and SDA lines, so that both are pulled high (recessive state) when the bus is free.

10.5 Extended Data Acquisition

10.5.1 Available Extended Data

For either the SPI or I²C interface, additional data is available beyond the pressure. The means to access this extended data is to continue reading data (either SPI or I²C) beyond the 24 bits of pressure information. The following table defines the order of the available data and respective format.

Data	Bytes	Format	Interpretation	Example
Mode	1	8 bit, Encoded	See Section 10.6	See Section 10.6
Pressure	2-4	3 byte, Unsigned Int	See Section 10.7	See Section 10.7
Temperature	5-6	2 byte, Signed Int	Fixed Decimal [8.8 bits], Upper 8 bits integer, lower 8 bits fractional. Temperature in °C	1880H (18.80H) = 24.5°C
Model	7-14	8 byte, ASCII, null terminated	Right reading ASCII with null termination	56H,4EH,30H,32H,36H,43H,4DH,00H = VN026CM
Serial Number	15-18	4 byte, Hex	Unique 4 byte serial for each part	2FD627A4H
Build Number	19-24	6 byte, ASCII, null terminated	Right reading ASCII with null termination	30H,31H,39H,37H,41H,00H = 0197A

10.5.2 SPI Extended Data Read

Reading the extended data while using the SPI interface is the same as shown in Section 10.3 with exception that the master continues to read during the same nSS sequence to read all 24 bytes of the extended data. Any portion of the 24 bytes can be read during the transfer. That is, for example, 6 bytes could be read to acquire only the pressure and temperature information. When reading the extended data, only the first two bytes sent to the sensor (User Mode and User Rate) are used to set the internal registers. The subsequent bytes (bytes 5 through 24) are ignored. Data read following the first 24 bytes is undefined.

10.5.3 I²C Extended Data Read

Reading the extended data via the I²C interface is similar to using the SPI interface where the master can simply continue to reading the sensor during the pressure reading transfer. The master continues Ack'ing until the number of desired bytes are read.

10.6 Control Registers

10.6.1 Mode Control Register

Default Value: 0x3F

Details of the Mode Control register are illustrated in the figure to the right.

Bits 0-2 control the output pressure range.

Bits 3-5 control the BW Limit Filter.

Bit 6-7 is reserved.

Please note the available pressure ranges for the different sensor models are indicated in the table. For values where the pressure range is not available for the given sensor, the table is highlighted in light orange and indicates the given full scale value to use for pressure conversion. It is possible to use these values.

It should also be noted that upon changing the Mode Control value, there is a one cycle latency before the new Mode Control value becomes valid. That is, the data of the communication cycle following a change to the Mode Control register will not reflect the change. It is not until the second communication cycle that the change in the Mode Control register will be reflected in the output data.

Mode Control Register Detail

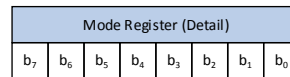
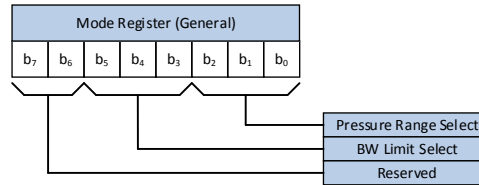

			Pressure Range Select (by Model)						
b ₇	b ₆	b ₅	VN025CM (cmH ₂ O)	VN026CM (cmH ₂ O)	VN130CM (cmH ₂ O)	VN131CM (cmH ₂ O)	VN-BARO (mbar)	VN150A (psia)	VN150D (psid)
0	0	0	± 5.0	±2.5	±80	±60	800-1100	0-80	±80
0	0	1	±5.0	±2.5	±80	±70	800-1100	0-90	±90
0	1	0	±5.0	±5.0	±80	±80	800-1100	0-100	±100
0	1	1	±7.5	±7.5	±90	±90	700-1100	0-110	±110
1	0	0	±10.0	±10.0	±100	±100	600-1100	0-120	±120
1	0	1	±15.0	±15.0	±110	±110	500-1100	0-130	±130
1	1	0	±20.0	±20.0	±120	±120	400-1100	0-140	±140
1	1	1	±25.0	±25.0	±130	±130	350-1100	0-150	±150

			BW Limit Select by Model						
b ₇	b ₆	b ₅	VN025CM	VN026CM	VN130CM	VN131CM	VN-BARO	VN150A	VN150D
0	0	0	20 Hz				1 Hz		
0	0	1	50 Hz				5 Hz		
0	1	0	100 Hz				10 Hz		
0	1	1	200 Hz				25 Hz		
1	0	0	300 Hz				50 Hz		
1	0	1	350 Hz				100 Hz		
1	1	0	400 Hz				200 Hz		
1	1	1	500 Hz				300 Hz		

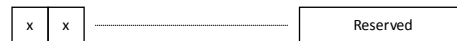

FIG-0143A

VN Series

Ventilator Pressure Sensors

10.6.2 Rate Control Register

Default Value: 0x01

The Rate Control Register controls the rate at which the DAV pin is asserted indicating new data is available. This register is primarily used to throttle down the actual data transfer rate (when using the DAV as the trigger to sample). This can be used to have the sensor interrupt the host at a given data rate and synchronize the sensor data stream to the application.

The function of this register is that it is the reload value of a data rate counter. The value of the Rate Control Register is the divisor of the 1.09 kHz internal data rate. Since a divisor of zero is not possible, a zero value replicated the fastest available data rate (highlighted in orange).

Note: Start-up time (t_{FRD}) for the sensor is approximately 55ms for the first sample to be settled. Requesting data during this time will result in invalid information. However, the time between interface detection (t_{IOD}) and the start-up time (t_{FRD}) can be used for configuring the Mode and Rate registers by performing a transfer with the desired Mode and Rate register values and discarding the received pressure data. After waiting the required start-up time, the sensor will respond with desired data since the Mode and Rate registers have been pre-established.

Rate Control Register Detail

Rate Control Register								
b ₇	b ₆	b ₅	b ₄	b ₃	b ₂	b ₁	b ₀	
0	0	0	0	0	0	0	0	1087.5 Hz
0	0	0	0	0	0	0	1	1087.5 Hz
0	0	0	0	0	0	1	0	543.8 Hz
0	0	0	0	0	0	1	1	363.5 Hz
1	1	1	1	1	1	1	0	4.28 Hz
1	1	1	1	1	1	1	1	4.26 Hz

FIG-0144A

10.7 Computing Pressure

The pressure data is in the form of 24 bit unsigned integer sent in the order of high byte then two lower bytes (big endian).

The selected range of each sensor is scaled into ninety percent (90%) of the digital output range (5% at either end of the 24 bit digital range). Refer to the figure at right for the transfer function of the VN Series by sensor model. Also see Section 10.6.1 for the available pressure ranges of the specific VN Series sensor models.

Examples of converting the digital output for the different sensor types are illustrated below.

For a differential sensor (VN026CM) set to a range of ±20 cmH₂O:

$$Eq 1: P_{cmH_2O} = 20 \text{ cmH}_2\text{O} * \frac{Out_{DIGITAL} - 50\% * (2^{24} - 1)}{90\% * (2^{23} - 1)}$$

For an absolute sensor (VN150A) set to a range of 0-130 psia:

$$Eq 2: P_{psia} = 130 \text{ psia} * \frac{Out_{DIGITAL} - 5\% * (2^{24} - 1)}{90\% * (2^{24} - 1)}$$

For a barometric sensor (VN-BARO) set to a range of 4000-1100 mbar:

$$Eq 3: P_{mbar} = 400 \text{ mbar} + (1100 \text{ mbar} - 400 \text{ mbar}) * \frac{Out_{DIGITAL} - 5\% * (2^{24} - 1)}{90\% * (2^{24} - 1)}$$

Or, a generic model can be used:

$$Eq 4: P_{out} = P_{range \cdot min} + (P_{range \cdot max} - P_{range \cdot min}) * \frac{Out_{DIGITAL} - 5\% * (2^{24} - 1)}{90\% * (2^{24} - 1)}$$

Note: To reduce computation time, only the upper 16 bits can be used (with lower resolution) to compute the pressure. That is, stop reading pressure data after the first two pressure bytes. In this case, substitute 2^{16} for 2^{24} and 2^{15} for 2^{23} respectively in the example equations.

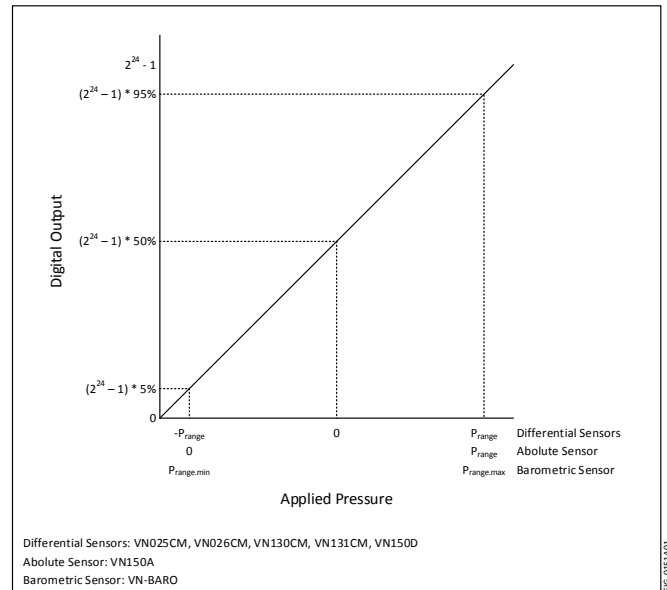

VN Series

Ventilator Pressure Sensors

11 Mechanical and Manufacturing

11.1 Package Dimensions

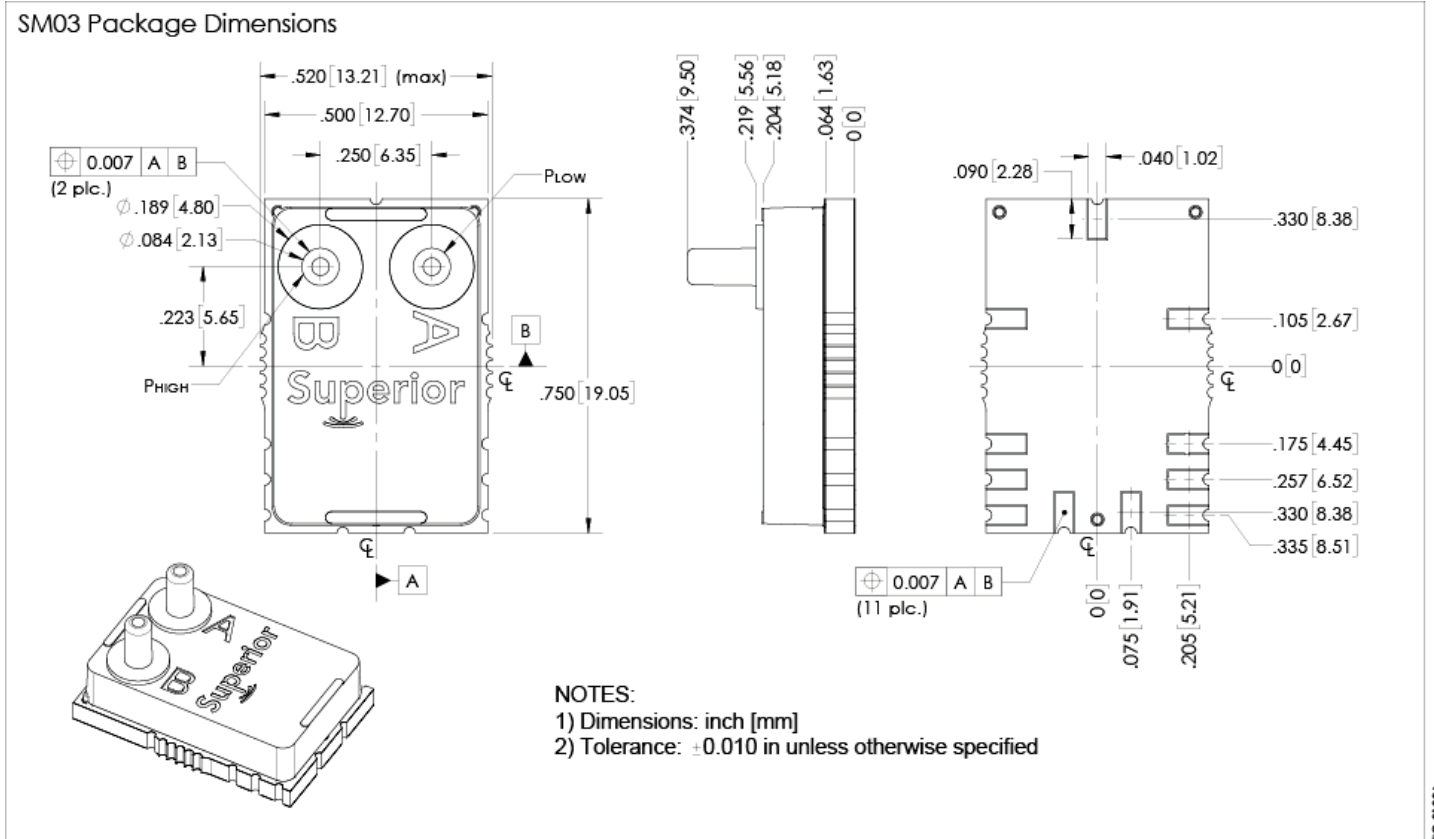

11.2 Suggested Pad Layout

The suggested pad layout is shown in the figure below. An Eagle PCB symbol library is available with the shown pad dimensions. Please consult the factory to obtain the library.

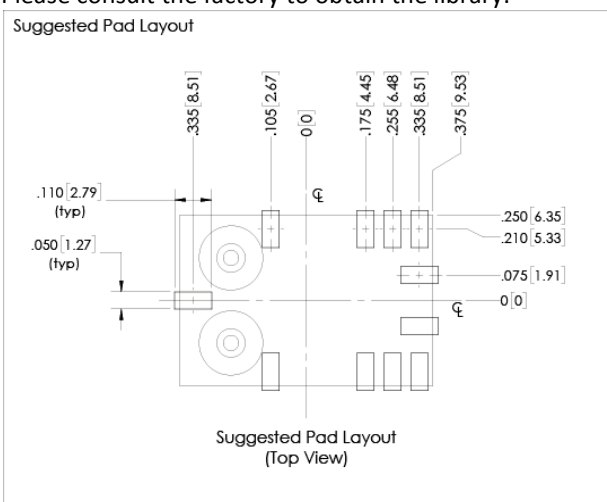

VN Series

Ventilator Pressure Sensors

11.3 Pinout

Pin	Sym	SPI	I ² C
1	nSS	Slave Select (active low)	Tie to Ground
2	MOSI/SCL	MOSI	SCL
3	MISO/SDA	MISO	SDA
4	SCK	Serial Clock	See Section 10.4.1
5	DNC	Do Not Connect	
6	DNC	Do Not Connect	
7	DNC	Do Not Connect	
8	Gnd	Ground	
9	V _{DD}	Sensor Supply	
10	nRST	Reset (active low)	
11	DAV	Data Available	

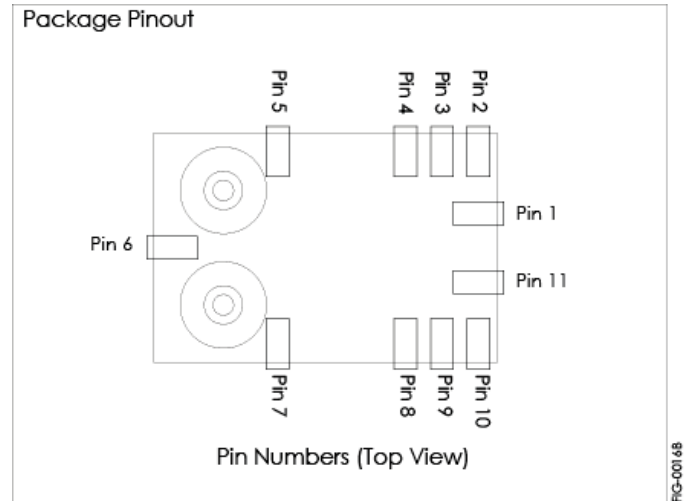

11.4 Reflow Soldering and Handling Conditions

Parameter	Sym	Val	Units
Soldering Specifications (Max) ^{1, 2}			
Preheat Ramp Rate	t _{PHRR}	3	°C/s
Soak Time	t _{SOAK}	3	min
Time Above 217C	t _{GT217}	50	s
Time Above 230C	t _{GT230}	40	s
Time Above 250C	t _{GT250}	15	s
Peak Temperature	t _{PT}	255	°C
Cooling Ramp Rate	t _{CRR}	-4	°C/s
Weight	W _{PRT}	3.5	gm
Moisture Sensitivity	MSL	3	
ESD (Human Body Model)	ESD	2	kV

Note 1) For lowest possible offset shift due to reflow, it is suggested to use a low temperature lead free solder.

Note 2) Pressure ports should not be exposed to cleaning agents. A no-clean solder is recommended.

11.5 Pick and Place Pick-up Zone

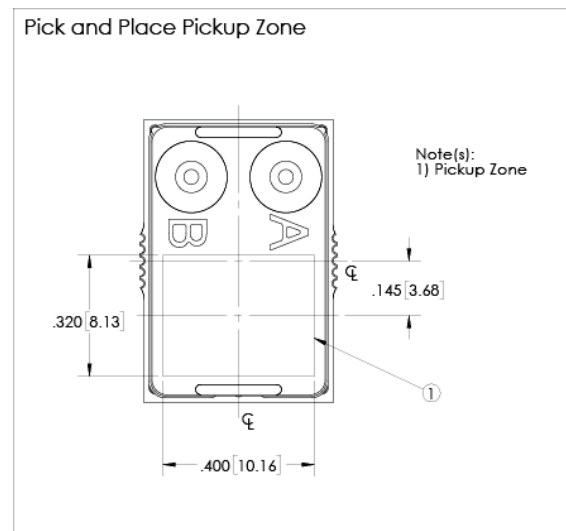

VN Series

Ventilator Pressure Sensors

11.6 Packaging Options

11.6.1 Tray Packaging

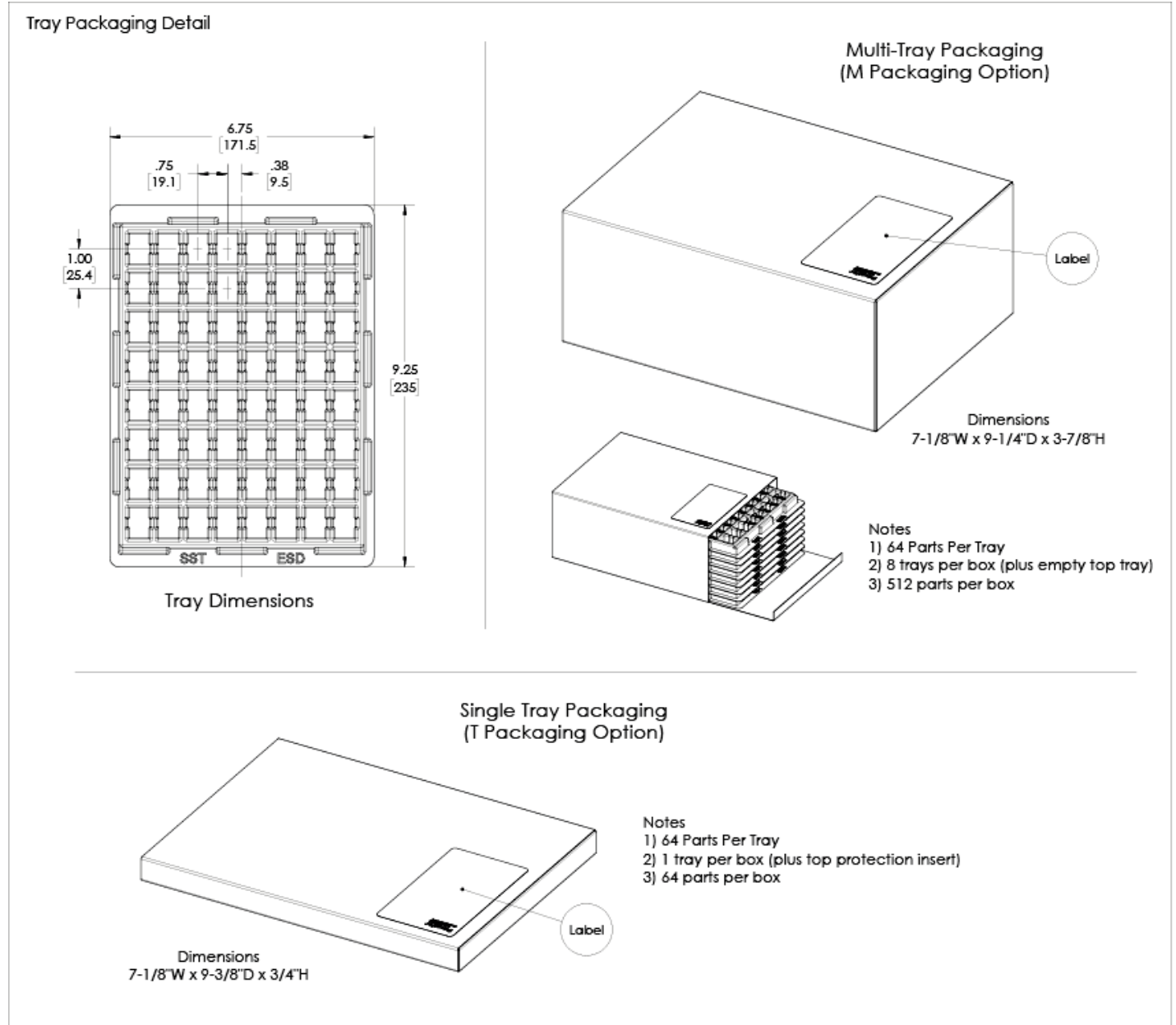
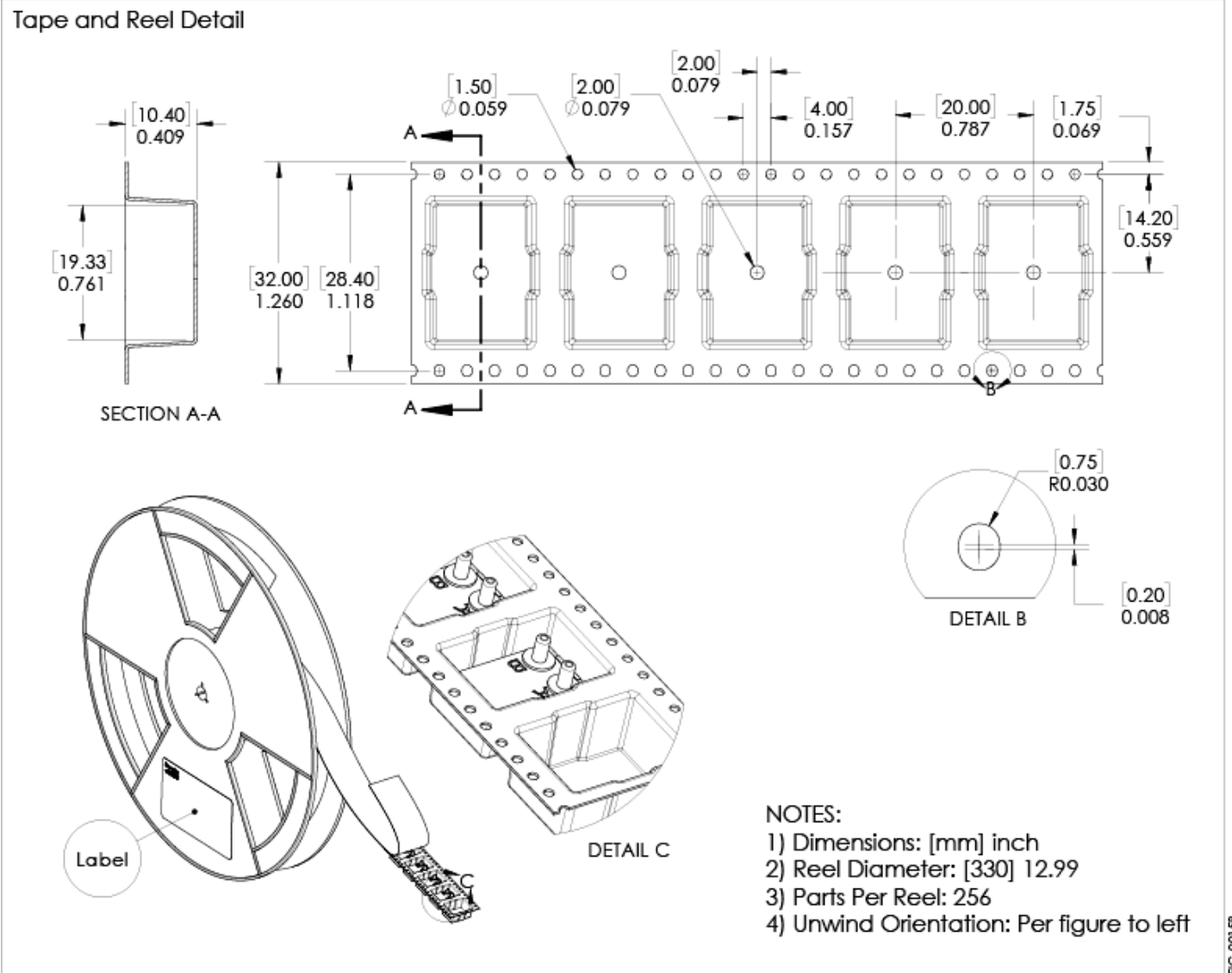

FIG-0022D

VN Series

Ventilator Pressure Sensors

11.6.2 Tape and Reel



11.7 Part Identification

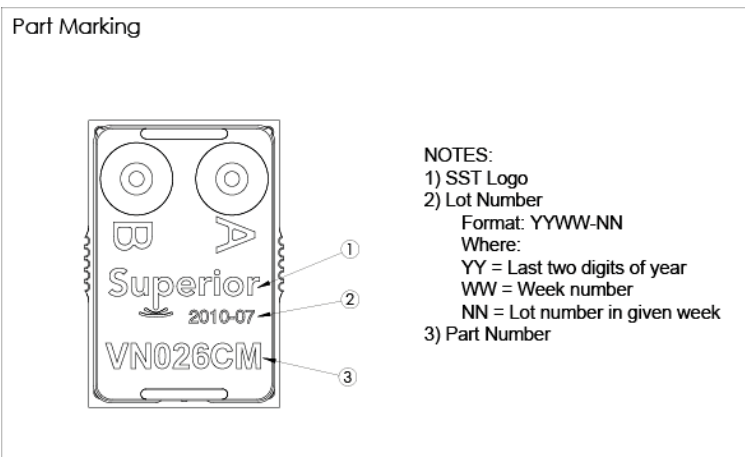

12 Packaging Labeling

Packaging labels are provided with barcode Code 128 symbology. The provided fields are Company Name, Part Number, Packaging ID and Quantity. The Packaging ID traces back to the Lot Number (or Lot Numbers) contained in the package. The purpose is to eliminate multiple labels (one for each included Lot Number) in the event of multiple Lot Numbers within a single package. This is for ease of customer tracking and maintenance. The Packaging ID is a 24 bit value printed in hexadecimal format.



13 Ordering Information

Part Number	Part Package	Packaging	Packaging Qty	Order Number
VN025CM-SM03	SM03	Tape and Reel	256	VN025CM-SM03-R
		Multi-Tray	512	VN025CM-SM03-M
		Single Tray	64	VN025CM-SM03-T
		Quarter Reel	64	VN025CM-SM03-Q
		Cut Tape	1-63	VN025CM-SM03-C
VN026CM-SM03	SM03	Tape and Reel	256	VN026CM-SM03-R
		Multi-Tray	512	VN026CM-SM03-M
		Single Tray	64	VN026CM-SM03-T
		Quarter Reel	64	VN026CM-SM03-Q
		Cut Tape	1-63	VN026CM-SM03-C
VN130CM-SM03	SM03	Tape and Reel	256	VN130CM-SM03-R
		Multi-Tray	512	VN130CM-SM03-M
		Single Tray	64	VN130CM-SM03-T
		Quarter Reel	64	VN130CM-SM03-Q
		Cut Tape	1-63	VN130CM-SM03-C
VN131CM-SM03	SM03	Tape and Reel	256	VN131CM-SM03-R
		Multi-Tray	512	VN131CM-SM03-M
		Single Tray	64	VN131CM-SM03-T
		Quarter Reel	64	VN131CM-SM03-Q
		Cut Tape	1-63	VN131CM-SM03-C
VN-BARO-SM03	SM03	Tape and Reel	256	VN-BARO-SM03-R
		Multi-Tray	512	VN-BARO-SM03-M
		Single Tray	64	VN-BARO-SM03-T
		Quarter Reel	64	VN-BARO-SM03-Q
		Cut Tape	1-63	VN-BARO-SM03-C
VN150A-SM03	SM03	Tape and Reel	256	VN150A-SM03-R
		Multi-Tray	512	VN150A-SM03-M
		Single Tray	64	VN150A-SM03-T
		Quarter Reel	64	VN150A-SM03-Q
		Cut Tape	1-63	VN150A-SM03-C
VN150D-SM03	SM03	Tape and Reel	256	VN150D-SM03-R
		Multi-Tray	512	VN150D-SM03-M
		Single Tray	64	VN150D-SM03-T
		Quarter Reel	64	VN150D-SM03-Q
		Cut Tape	1-63	VN150D-SM03-C

VN Series

Ventilator Pressure Sensors

14 Revisions

Rev	Change Description(s)	Date	By
A	Initial Release	11/22/22	T.S.
B	Revised 24 bit interface from signed to unsigned output. Add recommendation note to soldering profile table. Corrected miscellaneous typos.	3/8/23	T.S.

15 Warranty

Superior Sensor Technology and its subsidiaries warrant goods of its manufacture as being free of defective materials and faulty workmanship during the applicable warranty period. In all cases, Superior Sensor Technology's standard product warranty applies; please refer to your order acknowledgement or consult your local sales office for specific warranty details.

If warranted goods are returned to Superior Sensor Technology during the period of coverage, Superior Sensor Technology will repair or replace, at its option, without charge those items that Superior Sensor Technology, in its sole discretion, finds defective. **The foregoing is buyer's sole remedy and is in lieu of all other warranties, expressed or implied. In no event shall Superior Sensor Technology be liable for consequential, special, or indirect damages.**

While Superior Sensor Technology may provide application assistance personally, through literature or the Superior Sensor Technology web site, it is buyer's sole responsibility to determine the suitability of the product in their application. Superior Sensor Technology assumes no liability for applications assistance or customer product design.

Superior Sensor Technology reserves the right to make corrections, modifications, enhancements, improvements and other changes to its products and services at any time and to discontinue any product or service without notice. Customers should obtain the latest relevant information before placing orders and should verify that such information is current and complete.

Superior SENSOR TECHNOLOGY

103 Cooper Ct
Los Gatos, CA 95032

www.SuperiorSensors.com
info@SuperiorSensors.com
+1.408.703.2950

NimbleSense is a trademark of Superior Sensor Technology