

NOTES:

1. DO NOT SCALE THIS DRAWING.

2. UNLESS OTHERWISE SPECIFIED:

- A. HOLES, SLOTS AND DIAMETERS TO BE PARALLEL AND CONCENTRIC WITHIN .08 T.I.R.
- B. REMOVE ALL BURRS, BREAK ALL SHARP EDGES .13 MAX.
- C. SURFACE FINISH TO BE 1.6 MICROMETERS MAX.

備注:

- 1. 不要直接量測圖面.
- 2. 除非特別標示, 則:
 - A. 孔, 槽和外徑的同心度之總偏轉讀數最大0.08
 - B. 去除所有銳角C0.13 以下.
 - C. 表面粗糙度 Ra:3.2

THIRD ANGLE PROJ.

REVISIONS

REV	DESCRIPTION	DATE	ECO	APPR
A	RELEASE TO MFG.	17-Nov-05		SH
L	UPDATE MATERIAL SPEC.\VRD-DMI0081801S4	24-Aug-10	48246	SH

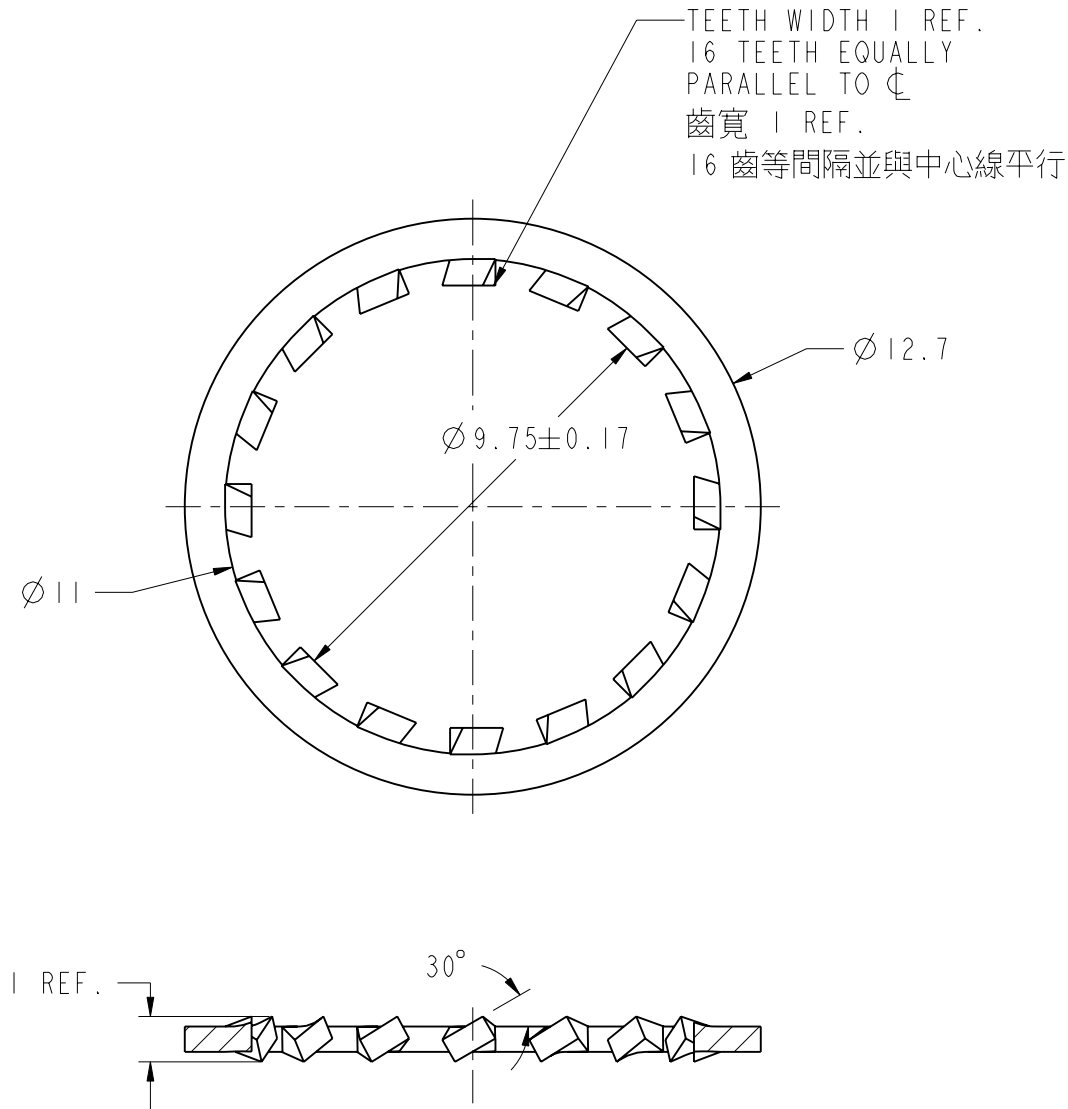

SCALE 3.000

SURFACE AREA = 140.774 SQ. MM.
VOLUME = 23.841 CU. MM.

UNLESS OTHERWISE SPECIFIED, DIMENSIONS ARE IN METRIC AND TOLERANCES ARE:
 <0.5mm ±0.05mm 0.5 - 6mm ±0.1mm 6 - 30mm ±0.2mm 30 - 120mm ±0.3mm ANGLES ±1°

NOTICE - These drawings, specifications, or other data (1) are, and remain the property of Amphenol corp. (2) must be returned upon request; and (3) are confidential and not to be disclosed to any person other than those to whom they are given by Amphenol Corp. the furnishing of these drawings, specifications, or other data by Amphenol Corp., or to any other person to anyone for any purpose is not to be regarded by implication or otherwise in any manner licensing, granting rights to permitting such holder or any other sperson to manufacture, use or sell any product, process or design, patented or otherwise, that may in any way be related to or disclosed by said drawings, specifications, or other data.

MATERIAL
PHOSPHOR BRONZE
JIS H3110-2006 C5191,H

REFERENCE AND CONFIGURATION LEVEL:
FINISH PER KAI JACK SPEC.EP-SS-9700

DRAWN
S.LI

ENGINEER
C.MCGRATH

APPROVED
S.HSIEH

CAD FILE
I:\Hard\5579

DATE
23-Aug-10

DATE
17-Dec-92

DATE
24-Aug-10

TITLE
LOCK WASHER

SCALE: 6.0:1.0

DWG SIZE
B

SHEET 1 OF 1

REV
L

Amphenol RF
Danbury CT USA, Tainan, Taiwan, Shenzhen, China
www.amphenolrf.com

DRAWING NO. 5579

ITEM NO. 5579L

PART NO. 5579