

DP149RSB Evaluation Module

This document describes how to use and configure the DP149RSBEVM along with recommendations for system hardware implementation. These recommendations are only guidelines and it is the designer's responsibility to consider all system characteristics and requirements. Refer to the datasheet for technical details such as device operation, terminal description, and so forth.

Contents

1	Overview	2
	1.1 What is the DP149?	2
	1.2 What is the DP149RSBEVM?	2
	1.3 What is Included in the DP149RSBEVM?	2
	1.4 What Does the EVM Look Like?	3
2	Hardware Description	3
	2.1 Video Connectors for DP149 Ports	4
	2.2 Enable/Reset	4
	2.3 Power	4
	2.4 Jumper Configuration	5
	2.5 Component Population Configuration	6
	2.6 Local I ² C Access through J5	6
	2.7 Local I ² C Access Through USB Interface via TUSB3410	7
	2.8 Rsdj Potentiometer	8
3	Quick Start Guide	8
4	References	8
5	Bill of Materials	9
6	EVM Schematics	11
7	EVM Layout	18

List of Figures

1	DP149RSBEVM	3
2	DP149RSB EVM Block Diagram	3
3	Register Status/Control Tab	7
4	Eyescan Tab	8
5	DP149RSBEVM Input Connectors Schematic	11
6	DP149RSB Schematic	12
7	DP149RSBEVM HDMI Schematic	13
8	DP149RSBEVM Select Options Schematic	14
9	DP149RSBEVM Reset Schematic	15
10	DP149RSBEVM Regulators Schematic	16
11	DP149RSBEVM TUSB3410 Schematic	17
12	Layer 1 (Top)	18
13	Layer 2 (GND)	18
14	Layer 3 (Power)	19
15	Layer 4 (Power)	19
16	Layer 5 (GND)	20

DisplayPort is a trademark of VESA.

17	Layer 6 (Bottom).....	20
----	-----------------------	----

1 Overview

1.1 What is the DP149?

The DP149 is a dual-mode DisplayPort™ to Transition Minimized Differential Signal (TMDS) retimer supporting digital video interface (DVI) 1.0 and high definition multimedia interface (HDMI) 1.4b output signals. The DP149 supports the dual-mode standard version 1.1 type 1 and type 2 through the DDC link. The DP149 supports data rate up to 3.4 Gbps per data lane to support UltraHD (4K×2K/30 Hz) 8 bits per color high resolution video and HDTV with 16-bit color depth at 1080p (1920×1080/60 Hz). The DP149 can automatically configure itself as a redriver at data rates < 1.0 Gbps or as a retimer above this data rate.

1.2 What is the DP149RSBEVM?

The DP149RSBEVM is a printed-circuit board (PCB) created to help customers evaluate the DP149 device for video applications. This EVM can also be used as a hardware reference design for implementation of the DP149 in the RSB package. PCB design/layout files are provided upon request to provide PCB design illustrations of the routing/placement rules.

Please note that the EVM design supports both the standard DP149 application and a DP149-thru-HDMI application, so it contains many components that would not be needed by a typical DP149 application. A separate reference design specific to DP149 is available for customers.

1.3 What is Included in the DP149RSBEVM?

The major components of the EVM are in the following list:

- DP149RSB
- Standard DP sink connector (connects to source)
- Standard HDMI source connector (connects to sink)
- DC power regulators
- I²C programming interface for external I²C host connection
- USB interface (I²C utility available)

1.4 What Does the EVM Look Like?

Figure 1 illustrates the EVM.

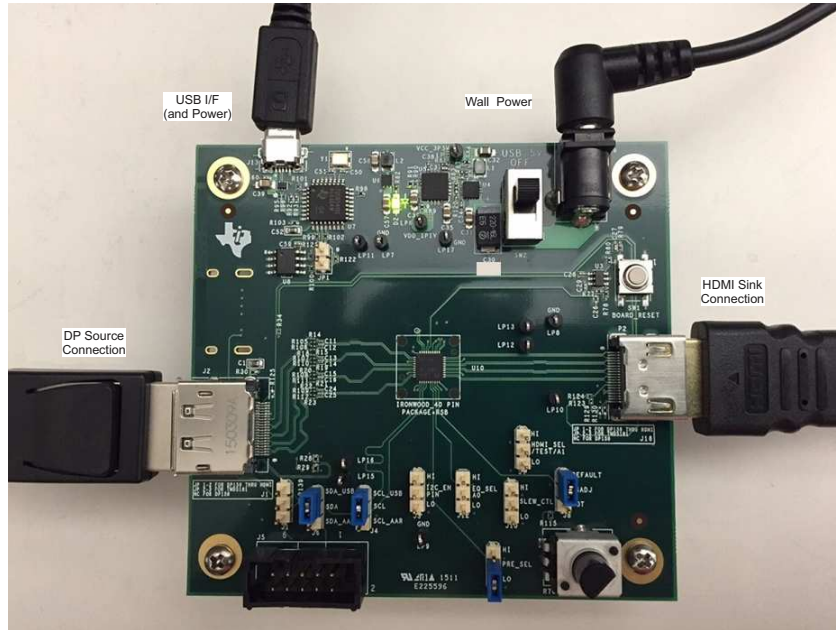
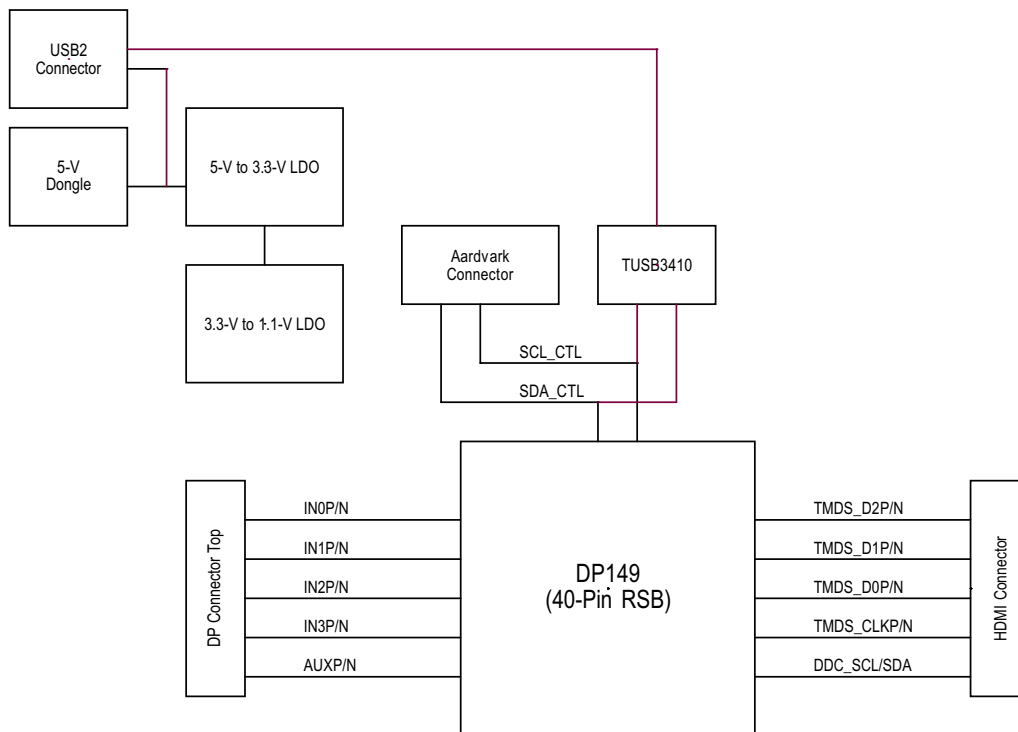

Figure 1. DP149RSBEVM

2 Hardware Description

Figure 2 illustrates the EVM block diagram.



100-Ω differential impedance for HDMI differential pairs.

Figure 2. DP149RSB EVM Block Diagram

2.1 Video Connectors for DP149 Ports

The EVM has a DP connection for the source and an HDMI connection for the sink. J2 is a standard DP connector (Molex 47272-0001). P2 is a standard HDMI connector (Molex 4715-10001). There is a third video connection on the board for an HDMI source (P1), this function is not installed on the DP149RSBEVM.

2.2 Enable/Reset

There are three device enable/reset options to use with the EVM:

- Supervisor circuitry option

This is the default configuration on the DP149RSBEVM. The enable (EN) signal is held low until the power good (PG) from the 3.3-V voltage regulator reaches a stable high voltage level, then released high.

- RC timing option

The C26 external capacitor and internal resistor are used to control the EN ramp time after the device is powered on. C26 is DNI (Do Not Install option) by default. Install C26 and uninstall R77 to enable this option.

- External control option

A push button (SW1) is provided for manual control of the DP149's EN/OE input.

2.3 Power

A DC power jack (J9) to accept a 5-V wall power adapter is provided on the EVM. The DC power jack (CUI Inc. PJ-202AH) has an inner diameter of 2.1 mm and an outer diameter of 5.5 mm. The tip of the 5-V power supply must be positive. A 5-V power supply of at least 1.5 A that meets the above requirements can be used to power the DP149RSBEVM. Power is provided to the EVM from the 5-V wall power adapter when SW2 is set to position 1.

WARNING

To minimize the risk of damage to equipment, care should be taken not to plug in any power source higher than the configured voltage (5 V).

Alternately, it is possible to power the EVM by connecting a USB Micro cable from J13 to a USB host and setting SW2 to position 3.

2.4 Jumper Configuration

Jumpers are provided to operate the device/EVM in different configurations. Jumper settings are listed in [Table 1](#).

Table 1. Jumper Settings

Jumper	Signal Name	Description	Default Configuration
J1	HPD_SRC	JP 1-2 for DP149 thru HDMI	NC
		JP 2-3 for DP149	Allows for 3.3-V to 5-V transition of HPD_SRC signal
		NC for DP149	
J3	I2C_EN_PIN	JP 1-2 for I2C ENABLE	NC
		JP 2-3 for PIN STRAP	Enables device configuration from I2C or pin straps
		NC – PIN STRAP (internal pulldown)	
J4	SCL	JP 1-2 for USB IF TO I2C	JP 1-2
		JP 2-3 for EXT IF TO I2C	USB I ² C Interface
		NC – N/A	
J6	SDA	JP 1-2 for USB IF TO I2C	JP 1-2
		JP 2-3 for EXT IF TO I2C	USB I ² C Interface
		NC – N/A	
J7	HDMI_SEL_A1	JP 1-2 for: <ul style="list-style-type: none"> I2C Addr bit A1 = 1, when I2C_EN = H DVI mode, when I2C_EN = L 	NC
		JP 2-3 for: <ul style="list-style-type: none"> I2C Addr bit A1 = 0, when I2C_EN = H HDMI mode, when I2C_EN = L 	
		NC for weak internal pulldown (Normal mode)	
J8	VSADJ	JP 1-2 for 6.5 kΩ	JP 1-2
		JP 2-3 for Adjustable resistance	Default of 6.5 kΩ
		NC – N/A	
J10	SLEW_CTL	JP 1-2 for Fastest Data Rate	NC
		JP 2-3 for 20 ps slow	
		NC for 40 ps slow	
J12	EQ_SEL_A0	JP 1-2 for: <ul style="list-style-type: none"> I2C Addr bit A0 = 1, when I2C_EN = H Fixed EQ at 14 dB, when I2C_EN = L 	NC
		JP 2-3 for: <ul style="list-style-type: none"> I2C Addr bit A0 = 0, when I2C_EN = H Fixed EQ at 7.5 dB, when I2C_EN = L 	
		NC for Adaptive EQ	
J15	PRE_SEL	JP 1-2 for N/A	JP 2-3
		JP 2-3 for –2.5 dB	
		NC for 0 dB	

2.5 Component Population Configuration

2.5.1 HPD Snoop Option

To accommodate systems that do not properly resend DDC commands after HPD goes low, an HPD snoop mode option is implemented on the DP149RSBEVM. This mode allows the HPD line to be routed around the DP149, but remain connected to the DP149 on the sink side to allow the DP149 to snoop its state. This snoop mode is disabled by default on the DP149RSBEVMs.

- Pop R131, no pop R129, R130, R139 for HPD on
- No pop R131, pop R129, R130, R139 for HPD snoop only

2.5.2 DDC Snoop Option

To accommodate systems that do not properly support clock stretching on the DDC lines, we have implemented a snoop mode on the DP149RSBEVM. This mode allows the DDC lines to be routed around the DP149RSB, but remain connected to the DP149RSB on the sink side to allow the DP149RSB to snoop the DDC traffic. This snoop mode is disabled by default on the DP149RSBEVMs.

Please note that snoop mode will connect the 3.3-V DDC lines on the DP interface to the 5.0-V DDC lines of the HDMI interface. Only enable this mode if the DP source can accept 5-V DDC signaling.

- Pop R28, R29, R31, R32. No pop R126, R136, R140, R141- DP149RSB, DDC on
- Pop R126, R136, R140, R141. No pop R28, R29, R31, R32 – DP149RSB, DDC snoop only

2.6 Local I²C Access through J5

Access to DP149's local I²C signals is provided via the J5 input connector. Note that I²C signal levels should be at 3.3 V when the I²C interface is accessed through the connector.

A standalone external I²C host can be connected via J5 for debug and control purposes. An example of an external I²C Host controller is the Total Phase Aardvark I²C/SPI Host Adapter (Total Phase Part#: [TP240141](#)). Sample scripts for this I²C Host controller are provided by request.

Table 2. Aardvark I²C (J5) Pin-Out

J5 pin #	Description	J5 pin #	Description
1	SCL_CTL	2	GND
3	SDA_CTL	4	NC
5	NC	6	NC
7	NC	8	NC
9	NC	10	GND

Table 3. DP149 Target I²C Address⁽¹⁾

DP149 I ² C Target Address							Bit 0 (W/R)
Bit 7 (MSB) A6	Bit 6 A5	Bit 5 A4	Bit 4 A3	Bit 3 A2	Bit 2 A1	Bit 1 A0	
1	0	1	1	1	1	0	0/1

⁽¹⁾ 7 Bit Address = 5Eh

NOTE: The target I²C address for DP149 can be modified with the EVM jumper settings.

2.7 Local PC Access Through USB Interface via TUSB3410

Access to DP149's local I²C signals is also provided through the TUSB3410 on the DP149RSBEVM using a USB TI Utility called Eye Scan. To use the utility:

- Install the Eye Scan software from Texas Instruments
- Set J6 to SDA – SDA_USB
- Set J4 to SCL – SCL_USB
- Attach a USB micro cable to J13 and to the host computer
Please note that the USB connection should be made prior to installing any DP or HDMI cables.
- Start the Eye Scan software

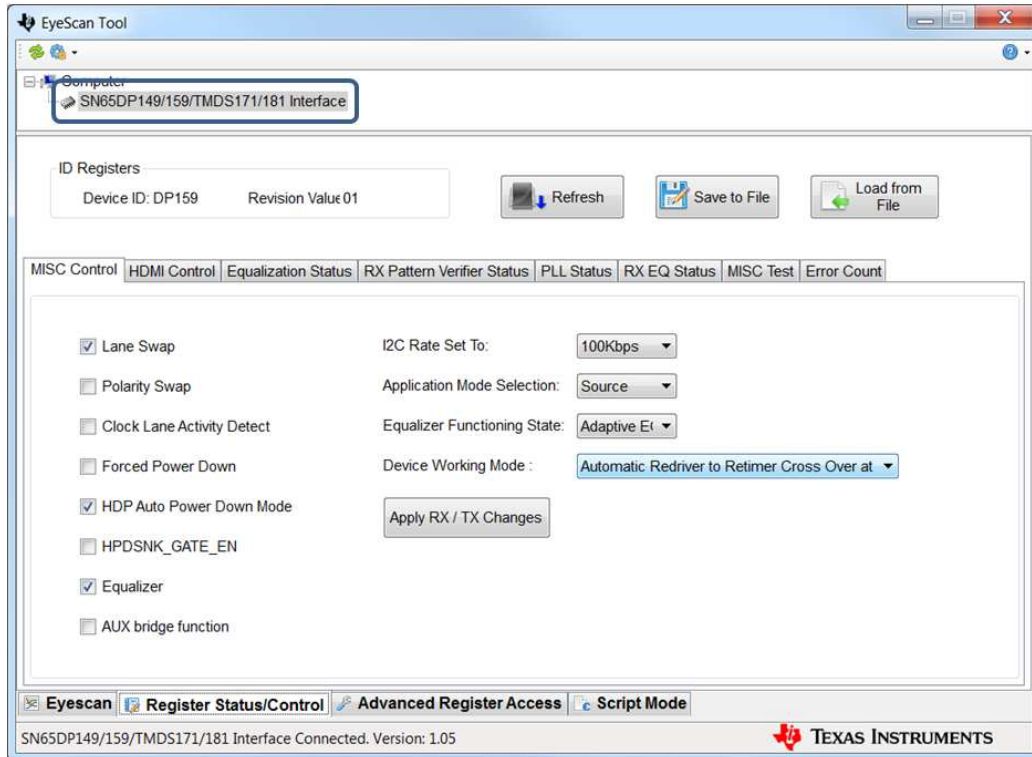

Figure 3. Register Status/Control Tab

Confirm that the SN65DP149/159/TMDS171/181 interface is present and selected at the top. If it is not, check the USB connection and confirm that the driver is loaded in *Device Manager*. It may take a moment for the USB driver to load. If the DP149RSB does not appear, hit the *Refresh* button. This tab can be used to read and write the status and control registers of the device.

To run an Eye Scan, select the *Eyescan* tab, select the relevant lanes, and press scan. Please note that Eye Scan cannot be performed when the device is in retimer mode, it does not function in redriver mode.

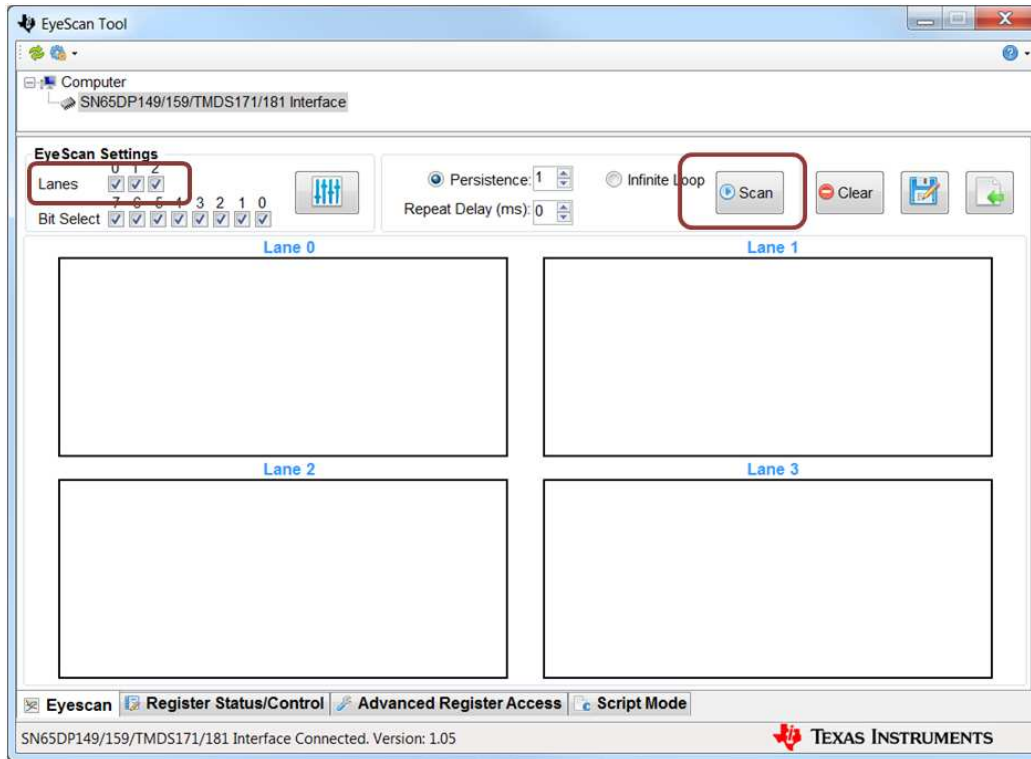

Figure 4. Eyescan Tab

2.8 Rsadj Potentiometer

The default Rsadj value on the DP149RSBEVM is 6.5 kΩ. The optimal value for an application may vary from 4.7 kΩ to 7 kΩ. To allow customers to test the effects of various Rsadj values, there is a potentiometer on the EVM at R76. The Rsadj value can be varied by turning the knob and setting J8 to [2,3].

3 Quick Start Guide

The following list provides the quick-start steps:

1. Connect USB cable from J13 to a USB host, set SW2 to 3. LED D2 should light up.
Option: Apply 5-V power to J9, set SW2 to 1. LED D2 should light up.
2. If using external I2C adapter instead of pin straps, please configure the DP149 at this step using J5 or through the USB interface.
3. Plug in a DP source using a standard DP cable into J2 (Standard DP connector).
4. Plug an HDMI video sink device into P2 (Standard HDMI connector) using a standard HDMI cable.
5. Video output on HDMI sink should be observed.

4 References

1. DP149 Datasheet
2. [Aardvark Adapter User's Guide](#)
3. High-Definition Multimedia Interface Specification Version 1.4b
4. High-Definition Multimedia Interface Specification Version 2.0

5 Bill of Materials

Table 4 lists the DP149RSB bill of materials (BOM).

Table 4. DP149RSBEVM Bill of Materials

Item	Quantity	Reference	Part	PCB Footprint	Manufacturer	Part Number
1	2	C1,C52	1uF	603	Taiyo Yuden	LMK107B7105KA-T
2	12	C9,C10,C17,C18,C19,C21,C23,C29,C40,C46,C59,C60	0.1uF	402	Yageo	CC0402KRX5R6BB104
3	5	C8,C20,C35,C36,C57	10uF	805	TDK	C2012X5R1A106K125AB
4	8	C11,C12,C13,C14,C15,C16,C24,C25	0.1uF	201	TDK	C0603X5R0J104M030BC
5	5	C22,C37,C41,C42,C47	0.01uF	402	Murata	GRM155R71H103KA88D
6	1	C26 - DNI	DNI - 200nF	402	Taiyo Yuden	LMK105BJ224KV-F
7	1	C27	18pF	402	AVX	04025A180JAT2A
8	1	C28	220pF	402	Taiyo Yuden	UMK105B7221KV-F
9	1	C30	220uF	7343	Kemet	T491D227K016AT
10	1	C34	3.3nF	402	Samsung	CL05B332KB5NNNC
11	1	C32	22uF	805	Murata	GRM21BR60J226ME39L
12	2	C39,C58	2.2uF	805	Taiyo Yuden	EMK212BJ225KG-T
13	1	C38 - DNI	1nF - DNI	402	Murata	GRM155R71H102KA01D
14	2	C45,C49	22pF	402	Murata	GRM1555C1H220JA01D
15	2	C50,C51	33pF	402	Murata	GRM1555C1H330JA01D
16	1	D1	Zener 6V	SOT23	Diodes Inc.	MMBZ5233B-FDICT-ND
17	1	D2	LED Green 0805	805	Lite On	LTST-C171GKT
18	1	JP1	JUMPER	HDR_THVT_1x2_100	3M	961102-6404-AR
19	9	J1,J3,J4,J6,J7,J8,J10,J12,J15	HDR3X1 M .1	HDR_THVT_1x3_100	3M	961103-6404-AR
20	1	J2	Display_Port_Connector_Sink_0	DISPLAYPORT	Molex	WM19271CT-ND
21	1	J5	Header 5x2 0.1" thru-hole	con_thvt_shrd_2x5_100_m	3M	N2510-6002-RB
22	1	J9	2.1mm x 5.5mm	CP-202AH-ND	CUI Inc.	CP-202AH-ND
23	1	J13	USB Micro B	USB Micro B	FCI	10103592-0001LF
24	12	LP5,LP6,LP7,LP8,LP9,LP10,LP11,LP12,LP13,LP15,LP16,LP17	LP	TESTLOOP	Keystone Electronics	5006
25	1	L1	2.2 uH	1008	TDK	VLS252010ET-2R2M
26	1	L2	1 uH	1008	TDK	NLCV25T-1R0M-EFR
27	4	L3, L4, L5, L6	CHOKE	805	Murata	DLW21SN900HQ2L
28	1	P1 - DNI	HDMI_IN - DNI	CON_HDMI_RT_19_0p50mm	Molex	WM19086CT-ND
29	1	P2	HDMI_OUT	CON_HDMI_RT_19_0p50mm	Molex	WM19086CT-ND
30	2	Q1,Q2	FDV301N_NFET_8V	SOT23	Fairchild Semiconductor	FDV301N
31	8	R1,R2,R3,R4,R6,R7,R8,R9	49.9	201	Panasonic	ERJ-1GEF49R9C
32	1	R5	100	402	Yageo	RC0402FR-07100RL
33	6	R10,R11,R99,R100,R101,R121	1K	402	Yageo	RC0402JR-071KL
34	3	R12,R27,R81	100K	402	Yageo	RC0402JR-07100KL
35	1	R13	10	402	Yageo	RC0402JR-0710RL
36	12	R31,R32,R33,R105,R106,R107,R108,R109,R110,R111,R112,R124	0	201	Panasonic	ERJ-1GN0R00C
37	6	R28,R29,R45,R46,R58,R59	2K	402	Yageo	RC0402JR-072KL

Table 4. DP149RSBEVM Bill of Materials (continued)

Item	Quantity	Reference	Part	PCB Footprint	Manufacturer	Part Number
38	7	R77,R80,R83,R84,R89,R122,R131	0	402	Panasonic	ERJ-2GE0R00X
39	1	R30	1M	402	Yageo	RC0402JR-071ML
40	10	R57,R60,R63,R64,R65,R66,R67,R68,R69,R70	64.9K	402	Yageo	RC0402FR-0764K9L
41	1	R75	6.49K	402	Panasonic	ERJ-2RKF6491X
42	1	R76	PTV09 10K POT	THRUHOLE	Bourns	PTV09A-4015F-B103
43	3	R78,R98,R102	10K	402	Yageo	RC0402JR-0710KLL
44	2	R79,R88	4.7K	402	Yageo	RC0402JR-074K7L
45	1	R82	499	402	Vishay Dale	CRCW0402499RDHEDP
46	1	R85	750K	402	Vishay Dale	CRCW0402750KJNED
47	1	R86	240K	402	Vishay Dale	CRCW0402240KJNED
48	1	R90	1.87K	402	Stackpole	RMCF0402FT1K87
49	1	R91	4.99K	402	Yageo	RC0402FR-074K99L
50	1	R94	1.5K	402	Yageo	RC0402JR-071K5L
51	2	R95,R96	33	201	Yageo	RC0201JR-0733RL
52	1	R103	15K	402	Yageo	RC0402JR-0715KLL
53	1	R115	47K	402	Rohm	MCR01MRTJ473
54	2	R16,R17 - DNI	2K - DNI	402	Yageo	RC0402JR-072KLL
55	1	R87 - DNI	10K - DNI	402	Yageo	RC0402JR-0710KLL
56	1	R92 - DNI	90.9K - DNI	402	Yageo	RC0402FR-0790K9L
57	1	R93 - DNI	100K - DNI	402	Yageo	RC0402FR-07100KLL
58	1	R130 - DNI	1K - DNI	402	Yageo	RC0402JR-071KLL
59	19	R14,R15,R18,R19,R20,R21,R22,R23,R24,R25,R34,R123,R126,R136,R134,R135,R139,R140,R141 - DNI	0 - DNI	201	Panasonic	ERJ-1GN0R00C
60	4	R104,R120,R125,R129 - DNI	0 - DNI	402	Panasonic	ERJ-2GE0R00X
61	1	SW1	PB_SWITCH	SW_MOM_2NO	OMRON	B3SN-3012P
62	1	SW2	3POS_SPDT	THRUHOLE_3POS	NKK Switches	MS13ANW03
63	1	U10	DP149RSB	40_RSB	TI	SN75DP149RSB
64	1	U3	TPS3808G30DBVT	6DBV	TI	TPS3808G30DBVT
65	1	U4	TPS62150ARGTT	RGT16	TI	TPS62150ARGTT
66	1	U6	TPS61240DRV	6DRV	TI	TPS61240DRV
67	1	U5	TPS74201RGWT	RGW20	TI	TPS74201RGWT
68	1	U7	TUSB3410VF	LQFP32	TI	TUSB3410VF
69	1	U8	CAT24C256WI-GT3	8SOIC	ON Semiconductor	CAT24C256WI-GT3
70	1	C31	10uF	805	TDK	C2012X5R1C106K085AC
71	1	U16	TPD2E001DRLR	dr1_5pin	TI	TPD2E001DRLR
72	1	Y1	12 MHz Crystal	ECX-32	ECS Inc.	ECS-120-20-33-TR
73	4	EVM Assembly	0.75" Standoff	4-40 - F/F	Keystone Electronics	2029
74	4	EVM Assembly	0.25" - Stainless Steel Screws	4-40 Phillips Panhead	Building Fasteners	PMSSS 440 0025 PH
75	4	Shunts	Shunt	SHUNT	3M	969102-0000-DA
76	1	PCB	DP149RSBEVM		ANY	INT023

6 EVM Schematics

Figure 5 through Figure 11 show the EVM schematics.

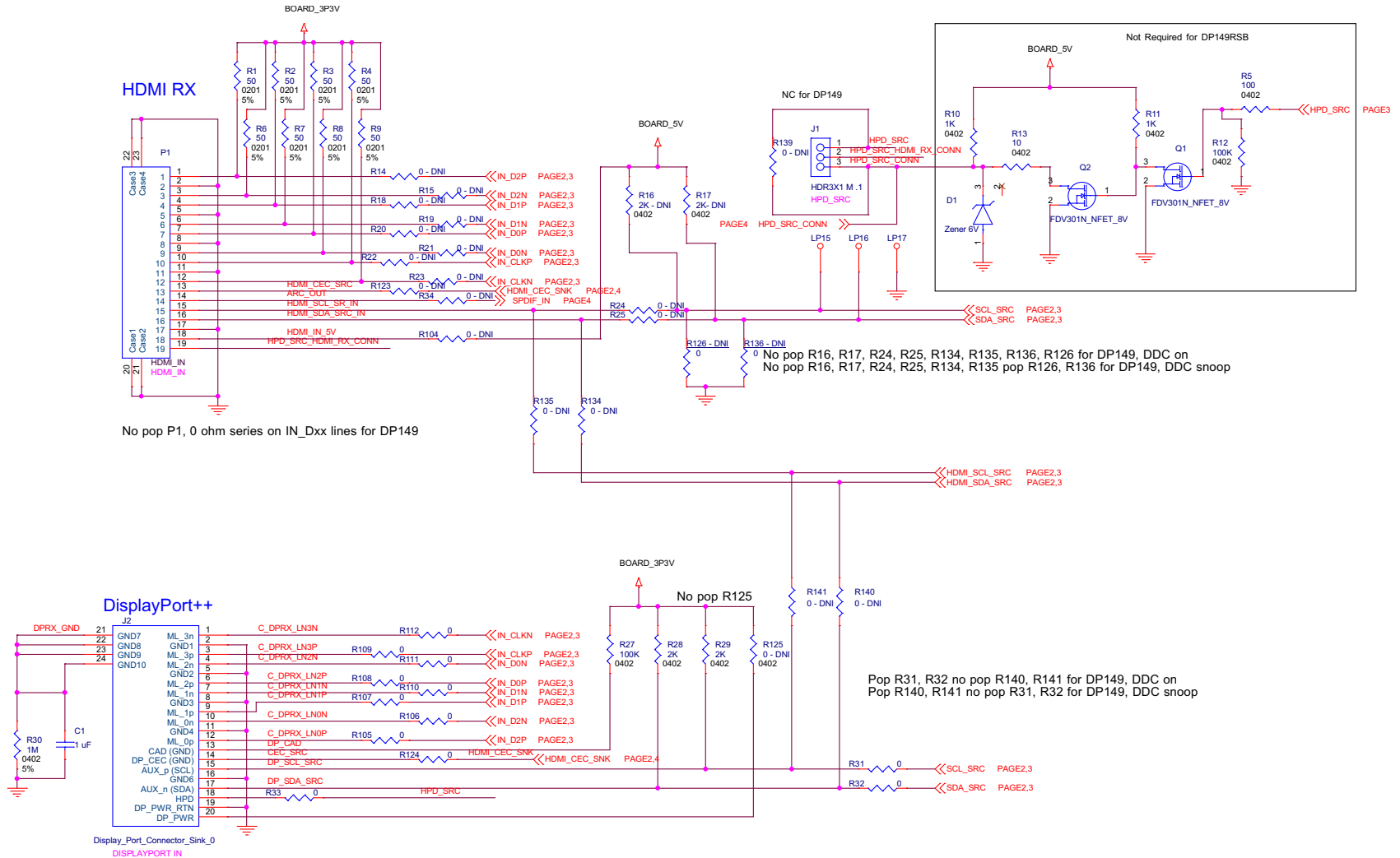

Figure 5. DP149RSBEVM Input Connectors Schematic

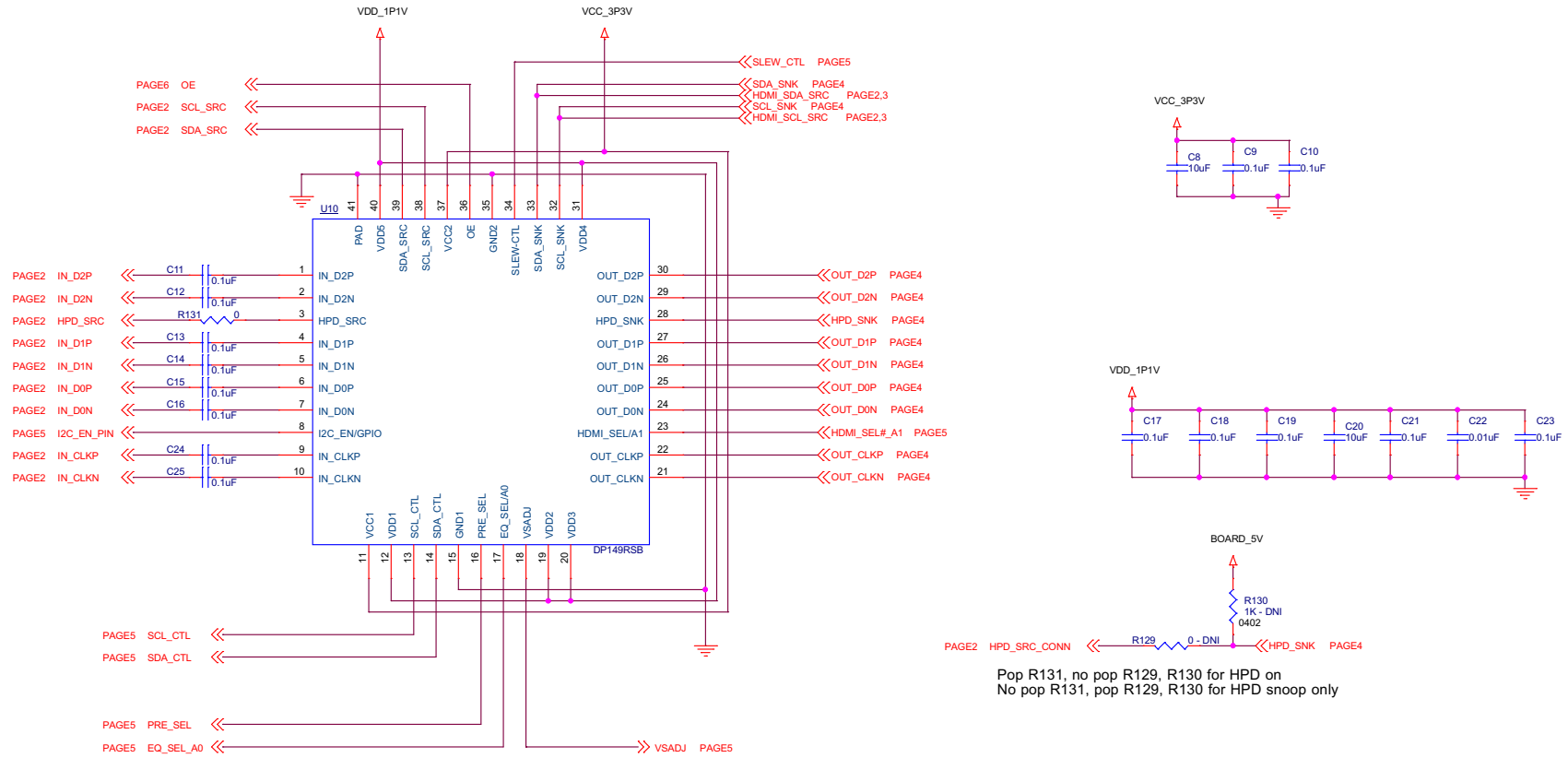

Figure 6. DP149RSB Schematic

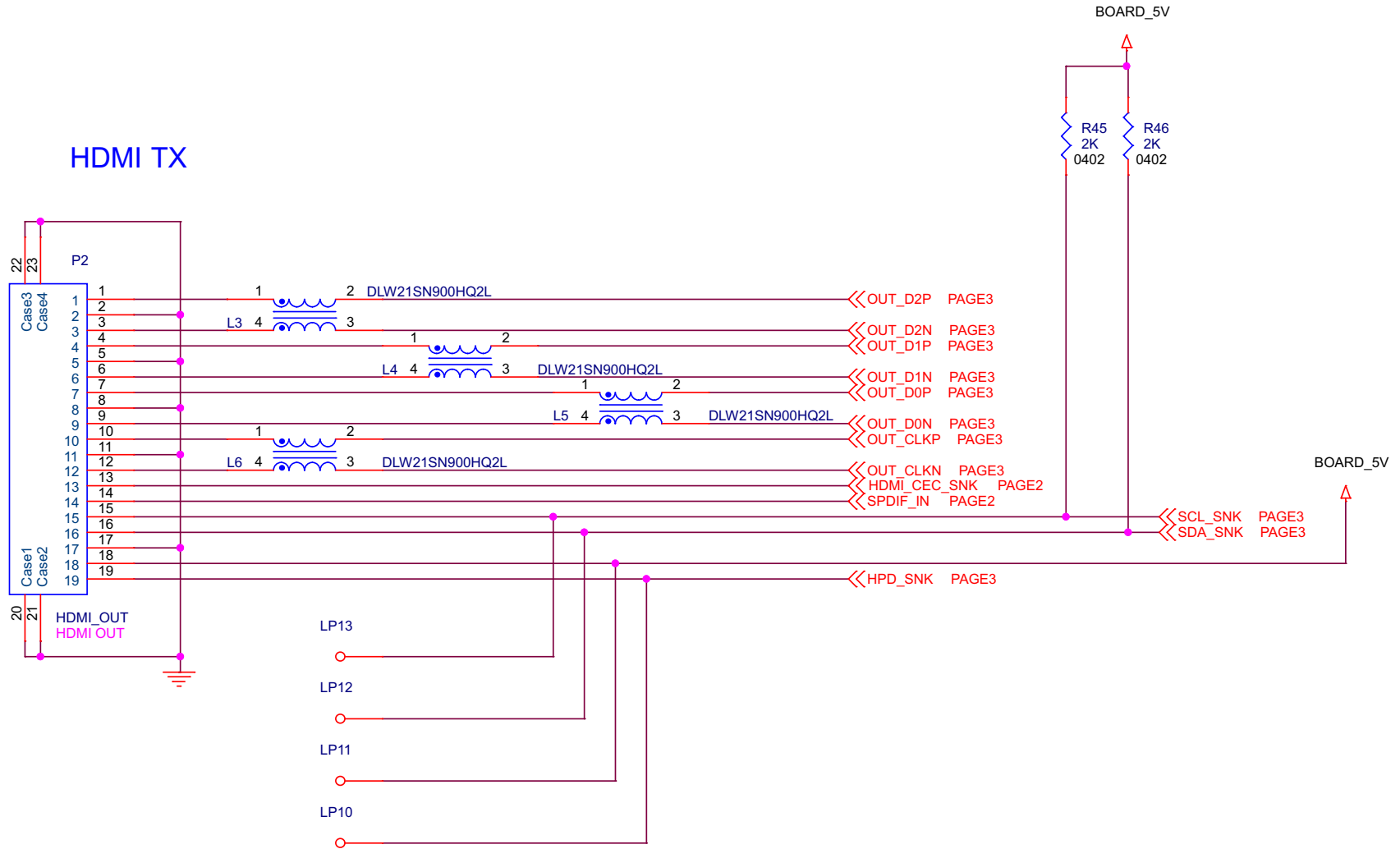

Figure 7. DP149RSBEVM HDMI Schematic

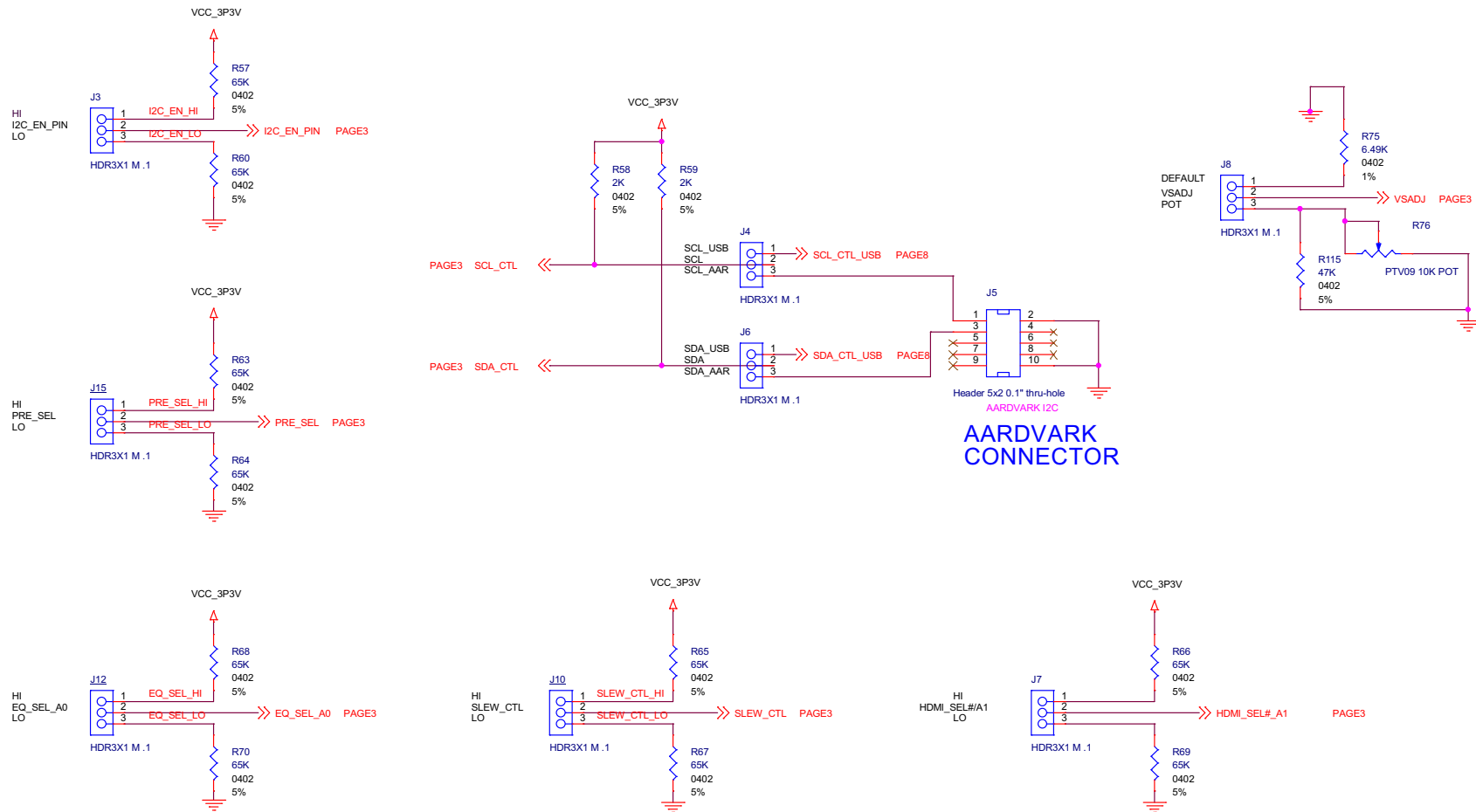

Figure 8. DP149RSBEVM Select Options Schematic

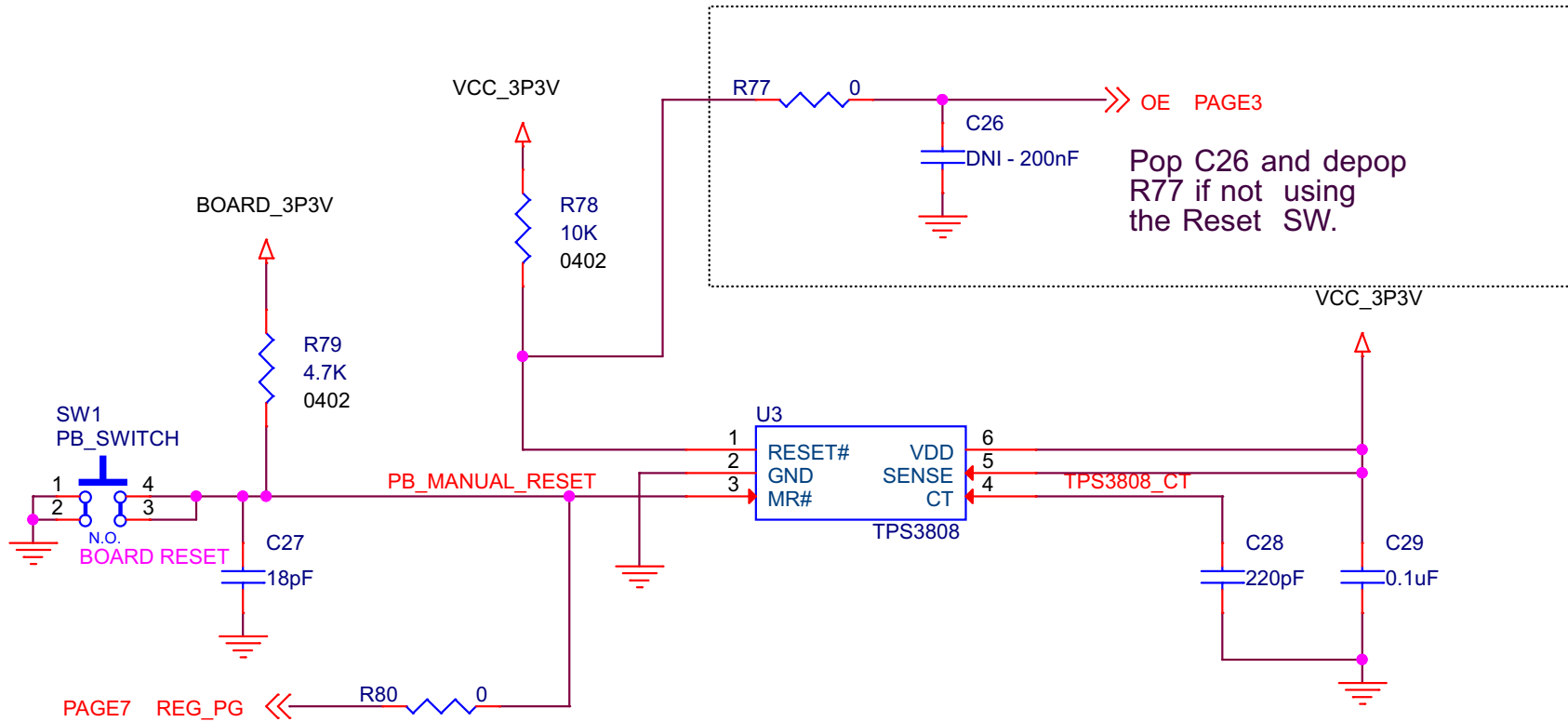

Figure 9. DP149RSBEVM Reset Schematic

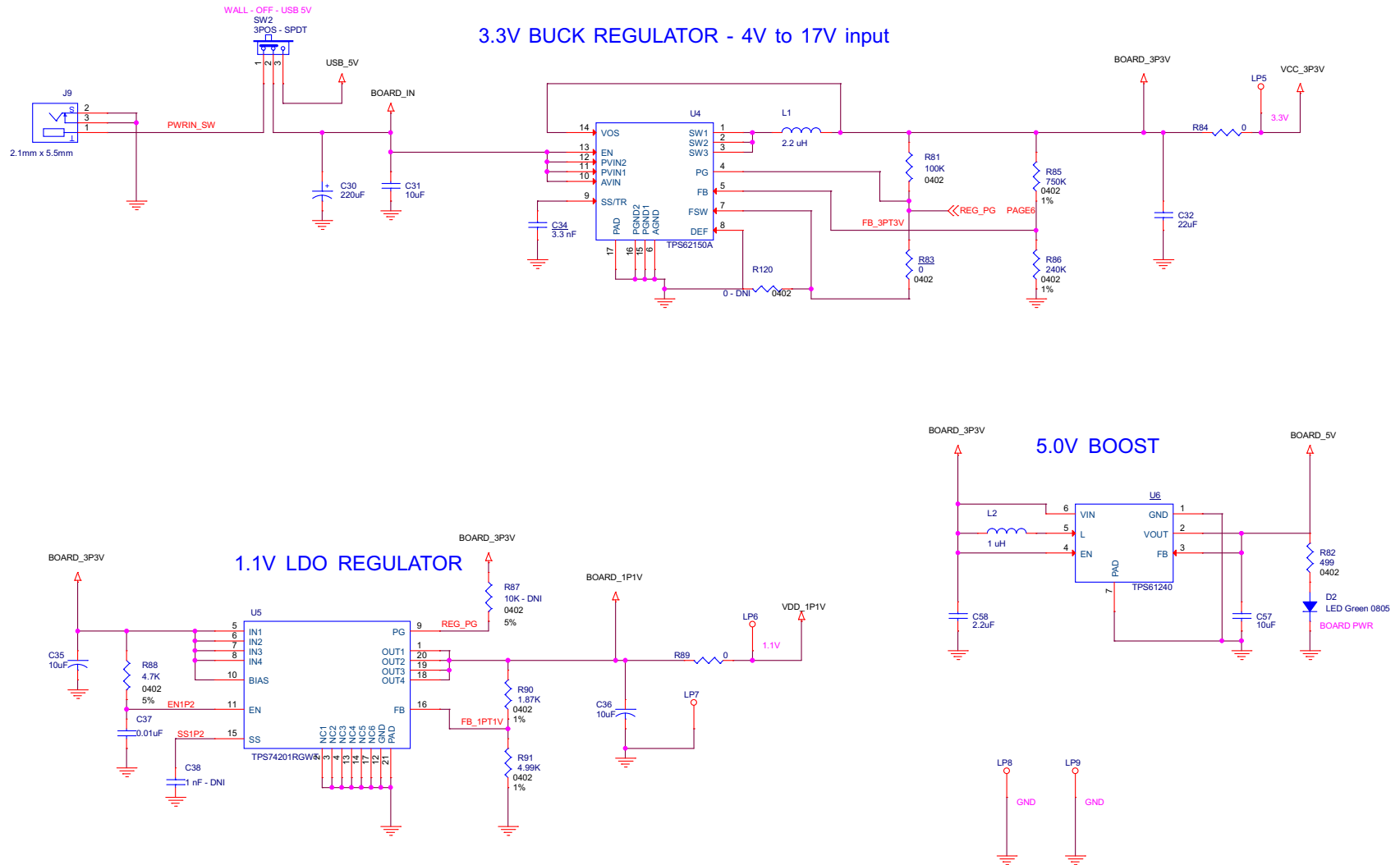

Figure 10. DP149RSBEVM Regulators Schematic

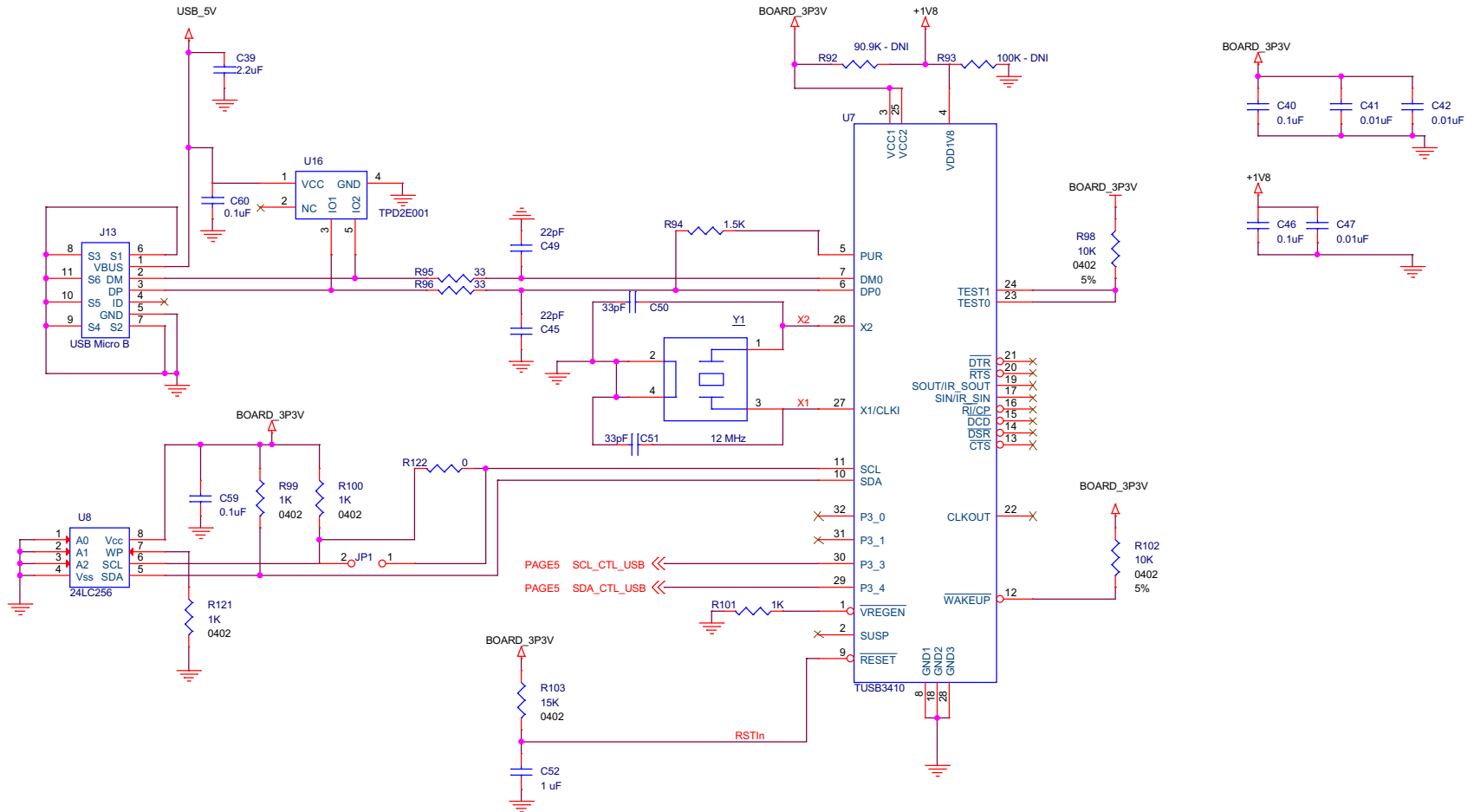

Figure 11. DP149RSBEVM TUSB3410 Schematic

7 EVM Layout

This section illustrates the PCB layouts in [Figure 12](#) through [Figure 17](#).

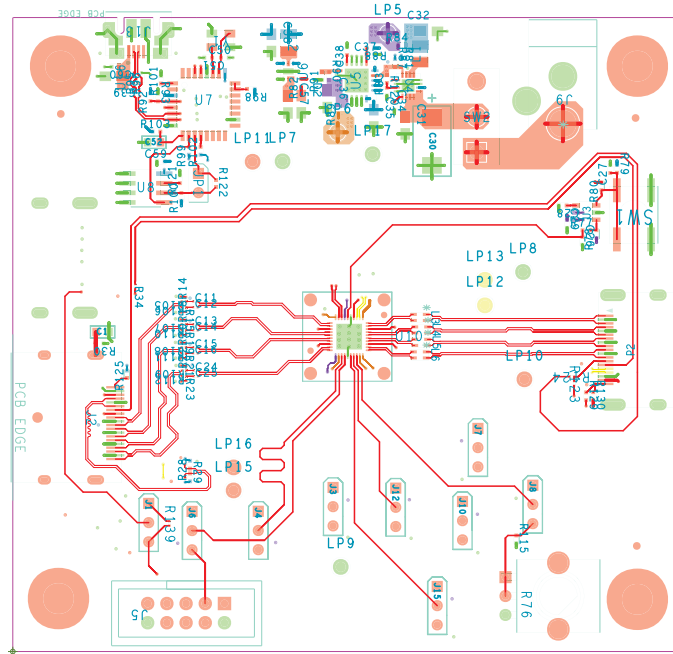

Figure 12. Layer 1 (Top)

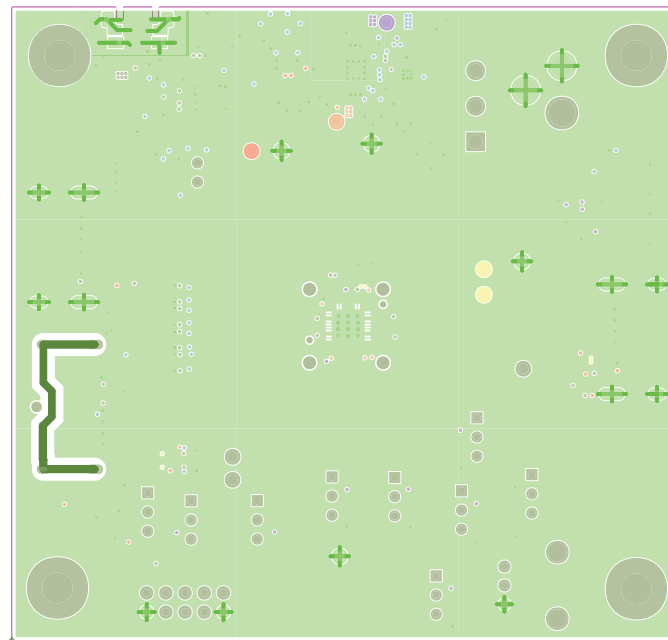

Figure 13. Layer 2 (GND)

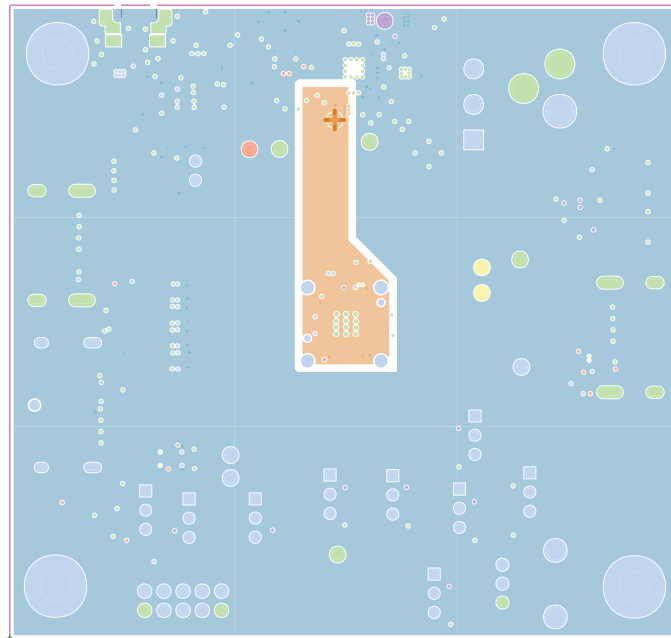

Figure 14. Layer 3 (Power)

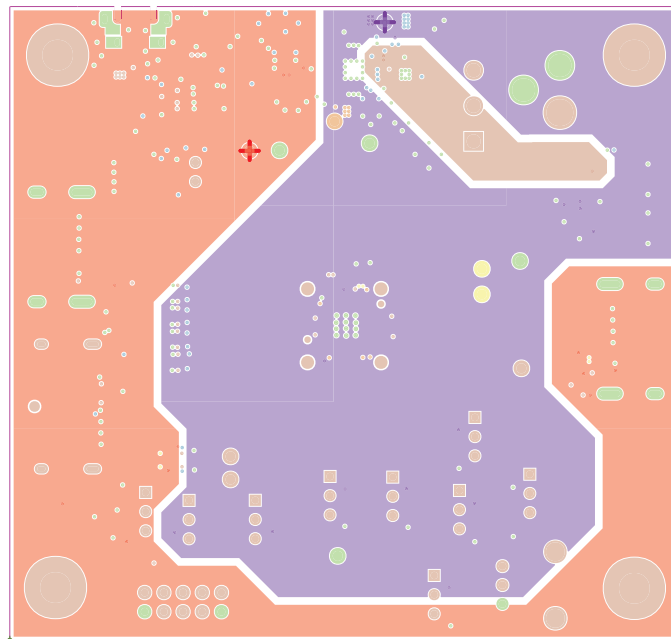

Figure 15. Layer 4 (Power)

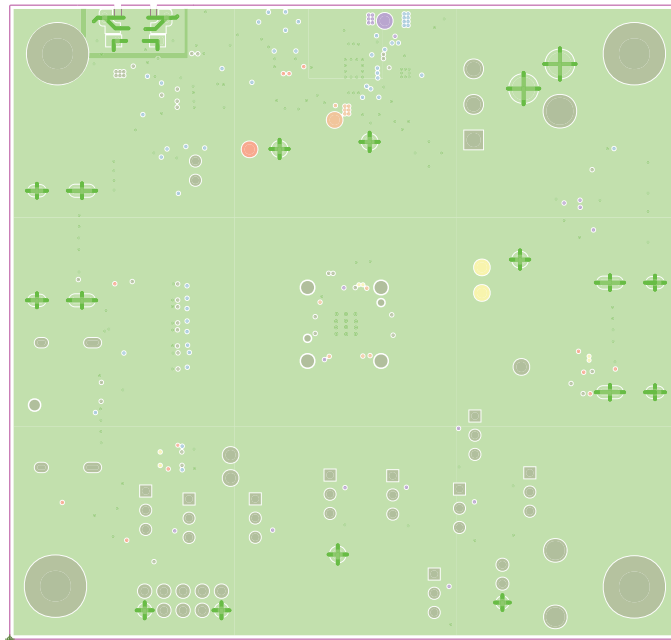

Figure 16. Layer 5 (GND)

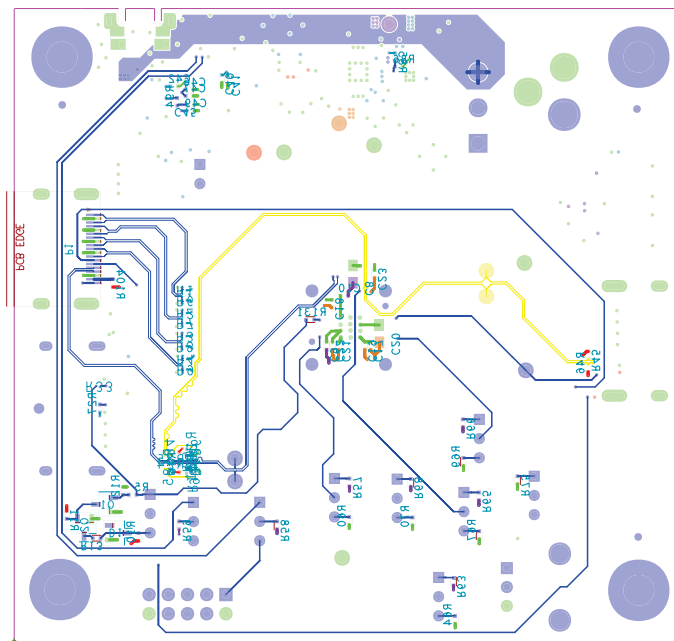

Figure 17. Layer 6 (Bottom)

STANDARD TERMS AND CONDITIONS FOR EVALUATION MODULES

1. *Delivery:* TI delivers TI evaluation boards, kits, or modules, including any accompanying demonstration software, components, or documentation (collectively, an "EVM" or "EVMs") to the User ("User") in accordance with the terms and conditions set forth herein. Acceptance of the EVM is expressly subject to the following terms and conditions.
 - 1.1 EVMs are intended solely for product or software developers for use in a research and development setting to facilitate feasibility evaluation, experimentation, or scientific analysis of TI semiconductors products. EVMs have no direct function and are not finished products. EVMs shall not be directly or indirectly assembled as a part or subassembly in any finished product. For clarification, any software or software tools provided with the EVM ("Software") shall not be subject to the terms and conditions set forth herein but rather shall be subject to the applicable terms and conditions that accompany such Software
 - 1.2 EVMs are not intended for consumer or household use. EVMs may not be sold, sublicensed, leased, rented, loaned, assigned, or otherwise distributed for commercial purposes by Users, in whole or in part, or used in any finished product or production system.
2. *Limited Warranty and Related Remedies/Disclaimers:*
 - 2.1 These terms and conditions do not apply to Software. The warranty, if any, for Software is covered in the applicable Software License Agreement.
 - 2.2 TI warrants that the TI EVM will conform to TI's published specifications for ninety (90) days after the date TI delivers such EVM to User. Notwithstanding the foregoing, TI shall not be liable for any defects that are caused by neglect, misuse or mistreatment by an entity other than TI, including improper installation or testing, or for any EVMs that have been altered or modified in any way by an entity other than TI. Moreover, TI shall not be liable for any defects that result from User's design, specifications or instructions for such EVMs. Testing and other quality control techniques are used to the extent TI deems necessary or as mandated by government requirements. TI does not test all parameters of each EVM.
 - 2.3 If any EVM fails to conform to the warranty set forth above, TI's sole liability shall be at its option to repair or replace such EVM, or credit User's account for such EVM. TI's liability under this warranty shall be limited to EVMs that are returned during the warranty period to the address designated by TI and that are determined by TI not to conform to such warranty. If TI elects to repair or replace such EVM, TI shall have a reasonable time to repair such EVM or provide replacements. Repaired EVMs shall be warranted for the remainder of the original warranty period. Replaced EVMs shall be warranted for a new full ninety (90) day warranty period.
3. *Regulatory Notices:*
 - 3.1 *United States*
 - 3.1.1 *Notice applicable to EVMs not FCC-Approved:*

This kit is designed to allow product developers to evaluate electronic components, circuitry, or software associated with the kit to determine whether to incorporate such items in a finished product and software developers to write software applications for use with the end product. This kit is not a finished product and when assembled may not be resold or otherwise marketed unless all required FCC equipment authorizations are first obtained. Operation is subject to the condition that this product not cause harmful interference to licensed radio stations and that this product accept harmful interference. Unless the assembled kit is designed to operate under part 15, part 18 or part 95 of this chapter, the operator of the kit must operate under the authority of an FCC license holder or must secure an experimental authorization under part 5 of this chapter.
 - 3.1.2 *For EVMs annotated as FCC – FEDERAL COMMUNICATIONS COMMISSION Part 15 Compliant:*

CAUTION

This device complies with part 15 of the FCC Rules. Operation is subject to the following two conditions: (1) This device may not cause harmful interference, and (2) this device must accept any interference received, including interference that may cause undesired operation.

Changes or modifications not expressly approved by the party responsible for compliance could void the user's authority to operate the equipment.

FCC Interference Statement for Class A EVM devices

NOTE: This equipment has been tested and found to comply with the limits for a Class A digital device, pursuant to part 15 of the FCC Rules. These limits are designed to provide reasonable protection against harmful interference when the equipment is operated in a commercial environment. This equipment generates, uses, and can radiate radio frequency energy and, if not installed and used in accordance with the instruction manual, may cause harmful interference to radio communications. Operation of this equipment in a residential area is likely to cause harmful interference in which case the user will be required to correct the interference at his own expense.

FCC Interference Statement for Class B EVM devices

NOTE: This equipment has been tested and found to comply with the limits for a Class B digital device, pursuant to part 15 of the FCC Rules. These limits are designed to provide reasonable protection against harmful interference in a residential installation. This equipment generates, uses and can radiate radio frequency energy and, if not installed and used in accordance with the instructions, may cause harmful interference to radio communications. However, there is no guarantee that interference will not occur in a particular installation. If this equipment does cause harmful interference to radio or television reception, which can be determined by turning the equipment off and on, the user is encouraged to try to correct the interference by one or more of the following measures:

- Reorient or relocate the receiving antenna.
- Increase the separation between the equipment and receiver.
- Connect the equipment into an outlet on a circuit different from that to which the receiver is connected.
- Consult the dealer or an experienced radio/TV technician for help.

3.2 Canada

3.2.1 For EVMs issued with an Industry Canada Certificate of Conformance to RSS-210

Concerning EVMs Including Radio Transmitters:

This device complies with Industry Canada license-exempt RSS standard(s). Operation is subject to the following two conditions: (1) this device may not cause interference, and (2) this device must accept any interference, including interference that may cause undesired operation of the device.

Concernant les EVMs avec appareils radio:

Le présent appareil est conforme aux CNR d'Industrie Canada applicables aux appareils radio exempts de licence. L'exploitation est autorisée aux deux conditions suivantes: (1) l'appareil ne doit pas produire de brouillage, et (2) l'utilisateur de l'appareil doit accepter tout brouillage radioélectrique subi, même si le brouillage est susceptible d'en compromettre le fonctionnement.

Concerning EVMs Including Detachable Antennas:

Under Industry Canada regulations, this radio transmitter may only operate using an antenna of a type and maximum (or lesser) gain approved for the transmitter by Industry Canada. To reduce potential radio interference to other users, the antenna type and its gain should be so chosen that the equivalent isotropically radiated power (e.i.r.p.) is not more than that necessary for successful communication. This radio transmitter has been approved by Industry Canada to operate with the antenna types listed in the user guide with the maximum permissible gain and required antenna impedance for each antenna type indicated. Antenna types not included in this list, having a gain greater than the maximum gain indicated for that type, are strictly prohibited for use with this device.

Concernant les EVMs avec antennes détachables

Conformément à la réglementation d'Industrie Canada, le présent émetteur radio peut fonctionner avec une antenne d'un type et d'un gain maximal (ou inférieur) approuvé pour l'émetteur par Industrie Canada. Dans le but de réduire les risques de brouillage radioélectrique à l'intention des autres utilisateurs, il faut choisir le type d'antenne et son gain de sorte que la puissance isotrope rayonnée équivalente (p.i.r.e.) ne dépasse pas l'intensité nécessaire à l'établissement d'une communication satisfaisante. Le présent émetteur radio a été approuvé par Industrie Canada pour fonctionner avec les types d'antenne énumérés dans le manuel d'usage et ayant un gain admissible maximal et l'impédance requise pour chaque type d'antenne. Les types d'antenne non inclus dans cette liste, ou dont le gain est supérieur au gain maximal indiqué, sont strictement interdits pour l'exploitation de l'émetteur.

3.3 Japan

3.3.1 *Notice for EVMs delivered in Japan:* Please see http://www.tij.co.jp/lstds/ti_ja/general/eStore/notice_01.page 日本国内に輸入される評価用キット、ボードについては、次のところをご覧ください。
http://www.tij.co.jp/lstds/ti_ja/general/eStore/notice_01.page

3.3.2 *Notice for Users of EVMs Considered "Radio Frequency Products" in Japan:* EVMs entering Japan may not be certified by TI as conforming to Technical Regulations of Radio Law of Japan.

If User uses EVMs in Japan, not certified to Technical Regulations of Radio Law of Japan, User is required by Radio Law of Japan to follow the instructions below with respect to EVMs:

1. Use EVMs in a shielded room or any other test facility as defined in the notification #173 issued by Ministry of Internal Affairs and Communications on March 28, 2006, based on Sub-section 1.1 of Article 6 of the Ministry's Rule for Enforcement of Radio Law of Japan,
2. Use EVMs only after User obtains the license of Test Radio Station as provided in Radio Law of Japan with respect to EVMs, or
3. Use of EVMs only after User obtains the Technical Regulations Conformity Certification as provided in Radio Law of Japan with respect to EVMs. Also, do not transfer EVMs, unless User gives the same notice above to the transferee. Please note that if User does not follow the instructions above, User will be subject to penalties of Radio Law of Japan.

【無線電波を送信する製品の開発キットをお使いになる際の注意事項】 開発キットの中には技術基準適合証明を受けていないものがあります。技術適合証明を受けていないもののご使用に際しては、電波法遵守のため、以下のいずれかの措置を取っていただく必要がありますのでご注意ください。

1. 電波法施行規則第6条第1項第1号に基づく平成18年3月28日総務省告示第173号で定められた電波暗室等の試験設備でご使用いただく。
2. 実験局の免許を取得後ご使用いただく。
3. 技術基準適合証明を取得後ご使用いただく。

なお、本製品は、上記の「ご使用にあたっての注意」を譲渡先、移転先に通知しない限り、譲渡、移転できないものとします。

上記を遵守頂けない場合は、電波法の罰則が適用される可能性があることをご留意ください。日本テキサス・インスツルメンツ株式会社
東京都新宿区西新宿 6 丁目 2 4 番 1 号
西新宿三井ビル

3.3.3 *Notice for EVMs for Power Line Communication:* Please see http://www.tij.co.jp/llds/ti_ja/general/eStore/notice_02.page
電力線搬送波通信についての開発キットをお使いになる際の注意事項については、次のところをご覧ください。http://www.tij.co.jp/llds/ti_ja/general/eStore/notice_02.page

4 *EVM Use Restrictions and Warnings:*

4.1 EVMS ARE NOT FOR USE IN FUNCTIONAL SAFETY AND/OR SAFETY CRITICAL EVALUATIONS, INCLUDING BUT NOT LIMITED TO EVALUATIONS OF LIFE SUPPORT APPLICATIONS.

4.2 User must read and apply the user guide and other available documentation provided by TI regarding the EVM prior to handling or using the EVM, including without limitation any warning or restriction notices. The notices contain important safety information related to, for example, temperatures and voltages.

4.3 *Safety-Related Warnings and Restrictions:*

4.3.1 User shall operate the EVM within TI's recommended specifications and environmental considerations stated in the user guide, other available documentation provided by TI, and any other applicable requirements and employ reasonable and customary safeguards. Exceeding the specified performance ratings and specifications (including but not limited to input and output voltage, current, power, and environmental ranges) for the EVM may cause personal injury or death, or property damage. If there are questions concerning performance ratings and specifications, User should contact a TI field representative prior to connecting interface electronics including input power and intended loads. Any loads applied outside of the specified output range may also result in unintended and/or inaccurate operation and/or possible permanent damage to the EVM and/or interface electronics. Please consult the EVM user guide prior to connecting any load to the EVM output. If there is uncertainty as to the load specification, please contact a TI field representative. During normal operation, even with the inputs and outputs kept within the specified allowable ranges, some circuit components may have elevated case temperatures. These components include but are not limited to linear regulators, switching transistors, pass transistors, current sense resistors, and heat sinks, which can be identified using the information in the associated documentation. When working with the EVM, please be aware that the EVM may become very warm.

4.3.2 EVMs are intended solely for use by technically qualified, professional electronics experts who are familiar with the dangers and application risks associated with handling electrical mechanical components, systems, and subsystems. User assumes all responsibility and liability for proper and safe handling and use of the EVM by User or its employees, affiliates, contractors or designees. User assumes all responsibility and liability to ensure that any interfaces (electronic and/or mechanical) between the EVM and any human body are designed with suitable isolation and means to safely limit accessible leakage currents to minimize the risk of electrical shock hazard. User assumes all responsibility and liability for any improper or unsafe handling or use of the EVM by User or its employees, affiliates, contractors or designees.

4.4 User assumes all responsibility and liability to determine whether the EVM is subject to any applicable international, federal, state, or local laws and regulations related to User's handling and use of the EVM and, if applicable, User assumes all responsibility and liability for compliance in all respects with such laws and regulations. User assumes all responsibility and liability for proper disposal and recycling of the EVM consistent with all applicable international, federal, state, and local requirements.

5. *Accuracy of Information:* To the extent TI provides information on the availability and function of EVMs, TI attempts to be as accurate as possible. However, TI does not warrant the accuracy of EVM descriptions, EVM availability or other information on its websites as accurate, complete, reliable, current, or error-free.

6. *Disclaimers:*
- 6.1 EXCEPT AS SET FORTH ABOVE, EVMS AND ANY WRITTEN DESIGN MATERIALS PROVIDED WITH THE EVM (AND THE DESIGN OF THE EVM ITSELF) ARE PROVIDED "AS IS" AND "WITH ALL FAULTS." TI DISCLAIMS ALL OTHER WARRANTIES, EXPRESS OR IMPLIED, REGARDING SUCH ITEMS, INCLUDING BUT NOT LIMITED TO ANY IMPLIED WARRANTIES OF MERCHANTABILITY OR FITNESS FOR A PARTICULAR PURPOSE OR NON-INFRINGEMENT OF ANY THIRD PARTY PATENTS, COPYRIGHTS, TRADE SECRETS OR OTHER INTELLECTUAL PROPERTY RIGHTS.
- 6.2 EXCEPT FOR THE LIMITED RIGHT TO USE THE EVM SET FORTH HEREIN, NOTHING IN THESE TERMS AND CONDITIONS SHALL BE CONSTRUED AS GRANTING OR CONFERRING ANY RIGHTS BY LICENSE, PATENT, OR ANY OTHER INDUSTRIAL OR INTELLECTUAL PROPERTY RIGHT OF TI, ITS SUPPLIERS/LICENSORS OR ANY OTHER THIRD PARTY, TO USE THE EVM IN ANY FINISHED END-USER OR READY-TO-USE FINAL PRODUCT, OR FOR ANY INVENTION, DISCOVERY OR IMPROVEMENT MADE, CONCEIVED OR ACQUIRED PRIOR TO OR AFTER DELIVERY OF THE EVM.
7. *USER'S INDEMNITY OBLIGATIONS AND REPRESENTATIONS.* USER WILL DEFEND, INDEMNIFY AND HOLD TI, ITS LICENSORS AND THEIR REPRESENTATIVES HARMLESS FROM AND AGAINST ANY AND ALL CLAIMS, DAMAGES, LOSSES, EXPENSES, COSTS AND LIABILITIES (COLLECTIVELY, "CLAIMS") ARISING OUT OF OR IN CONNECTION WITH ANY HANDLING OR USE OF THE EVM THAT IS NOT IN ACCORDANCE WITH THESE TERMS AND CONDITIONS. THIS OBLIGATION SHALL APPLY WHETHER CLAIMS ARISE UNDER STATUTE, REGULATION, OR THE LAW OF TORT, CONTRACT OR ANY OTHER LEGAL THEORY, AND EVEN IF THE EVM FAILS TO PERFORM AS DESCRIBED OR EXPECTED.
8. *Limitations on Damages and Liability:*
- 8.1 *General Limitations.* IN NO EVENT SHALL TI BE LIABLE FOR ANY SPECIAL, COLLATERAL, INDIRECT, PUNITIVE, INCIDENTAL, CONSEQUENTIAL, OR EXEMPLARY DAMAGES IN CONNECTION WITH OR ARISING OUT OF THESE TERMS AND CONDITIONS OR THE USE OF THE EVMS PROVIDED HEREUNDER, REGARDLESS OF WHETHER TI HAS BEEN ADVISED OF THE POSSIBILITY OF SUCH DAMAGES. EXCLUDED DAMAGES INCLUDE, BUT ARE NOT LIMITED TO, COST OF REMOVAL OR REINSTALLATION, ANCILLARY COSTS TO THE PROCUREMENT OF SUBSTITUTE GOODS OR SERVICES, RETESTING, OUTSIDE COMPUTER TIME, LABOR COSTS, LOSS OF GOODWILL, LOSS OF PROFITS, LOSS OF SAVINGS, LOSS OF USE, LOSS OF DATA, OR BUSINESS INTERRUPTION. NO CLAIM, SUIT OR ACTION SHALL BE BROUGHT AGAINST TI MORE THAN ONE YEAR AFTER THE RELATED CAUSE OF ACTION HAS OCCURRED.
- 8.2 *Specific Limitations.* IN NO EVENT SHALL TI'S AGGREGATE LIABILITY FROM ANY WARRANTY OR OTHER OBLIGATION ARISING OUT OF OR IN CONNECTION WITH THESE TERMS AND CONDITIONS, OR ANY USE OF ANY TI EVM PROVIDED HEREUNDER, EXCEED THE TOTAL AMOUNT PAID TO TI FOR THE PARTICULAR UNITS SOLD UNDER THESE TERMS AND CONDITIONS WITH RESPECT TO WHICH LOSSES OR DAMAGES ARE CLAIMED. THE EXISTENCE OF MORE THAN ONE CLAIM AGAINST THE PARTICULAR UNITS SOLD TO USER UNDER THESE TERMS AND CONDITIONS SHALL NOT ENLARGE OR EXTEND THIS LIMIT.
9. *Return Policy.* Except as otherwise provided, TI does not offer any refunds, returns, or exchanges. Furthermore, no return of EVM(s) will be accepted if the package has been opened and no return of the EVM(s) will be accepted if they are damaged or otherwise not in a resalable condition. If User feels it has been incorrectly charged for the EVM(s) it ordered or that delivery violates the applicable order, User should contact TI. All refunds will be made in full within thirty (30) working days from the return of the components(s), excluding any postage or packaging costs.
10. *Governing Law:* These terms and conditions shall be governed by and interpreted in accordance with the laws of the State of Texas, without reference to conflict-of-laws principles. User agrees that non-exclusive jurisdiction for any dispute arising out of or relating to these terms and conditions lies within courts located in the State of Texas and consents to venue in Dallas County, Texas. Notwithstanding the foregoing, any judgment may be enforced in any United States or foreign court, and TI may seek injunctive relief in any United States or foreign court.

Mailing Address: Texas Instruments, Post Office Box 655303, Dallas, Texas 75265
Copyright © 2015, Texas Instruments Incorporated

IMPORTANT NOTICE

Texas Instruments Incorporated and its subsidiaries (TI) reserve the right to make corrections, enhancements, improvements and other changes to its semiconductor products and services per JESD46, latest issue, and to discontinue any product or service per JESD48, latest issue. Buyers should obtain the latest relevant information before placing orders and should verify that such information is current and complete. All semiconductor products (also referred to herein as "components") are sold subject to TI's terms and conditions of sale supplied at the time of order acknowledgment.

TI warrants performance of its components to the specifications applicable at the time of sale, in accordance with the warranty in TI's terms and conditions of sale of semiconductor products. Testing and other quality control techniques are used to the extent TI deems necessary to support this warranty. Except where mandated by applicable law, testing of all parameters of each component is not necessarily performed.

TI assumes no liability for applications assistance or the design of Buyers' products. Buyers are responsible for their products and applications using TI components. To minimize the risks associated with Buyers' products and applications, Buyers should provide adequate design and operating safeguards.

TI does not warrant or represent that any license, either express or implied, is granted under any patent right, copyright, mask work right, or other intellectual property right relating to any combination, machine, or process in which TI components or services are used. Information published by TI regarding third-party products or services does not constitute a license to use such products or services or a warranty or endorsement thereof. Use of such information may require a license from a third party under the patents or other intellectual property of the third party, or a license from TI under the patents or other intellectual property of TI.

Reproduction of significant portions of TI information in TI data books or data sheets is permissible only if reproduction is without alteration and is accompanied by all associated warranties, conditions, limitations, and notices. TI is not responsible or liable for such altered documentation. Information of third parties may be subject to additional restrictions.

Resale of TI components or services with statements different from or beyond the parameters stated by TI for that component or service voids all express and any implied warranties for the associated TI component or service and is an unfair and deceptive business practice. TI is not responsible or liable for any such statements.

Buyer acknowledges and agrees that it is solely responsible for compliance with all legal, regulatory and safety-related requirements concerning its products, and any use of TI components in its applications, notwithstanding any applications-related information or support that may be provided by TI. Buyer represents and agrees that it has all the necessary expertise to create and implement safeguards which anticipate dangerous consequences of failures, monitor failures and their consequences, lessen the likelihood of failures that might cause harm and take appropriate remedial actions. Buyer will fully indemnify TI and its representatives against any damages arising out of the use of any TI components in safety-critical applications.

In some cases, TI components may be promoted specifically to facilitate safety-related applications. With such components, TI's goal is to help enable customers to design and create their own end-product solutions that meet applicable functional safety standards and requirements. Nonetheless, such components are subject to these terms.

No TI components are authorized for use in FDA Class III (or similar life-critical medical equipment) unless authorized officers of the parties have executed a special agreement specifically governing such use.

Only those TI components which TI has specifically designated as military grade or "enhanced plastic" are designed and intended for use in military/aerospace applications or environments. Buyer acknowledges and agrees that any military or aerospace use of TI components which have **not** been so designated is solely at the Buyer's risk, and that Buyer is solely responsible for compliance with all legal and regulatory requirements in connection with such use.

TI has specifically designated certain components as meeting ISO/TS16949 requirements, mainly for automotive use. In any case of use of non-designated products, TI will not be responsible for any failure to meet ISO/TS16949.

Products

Audio	www.ti.com/audio
Amplifiers	amplifier.ti.com
Data Converters	dataconverter.ti.com
DLP® Products	www.dlp.com
DSP	dsp.ti.com
Clocks and Timers	www.ti.com/clocks
Interface	interface.ti.com
Logic	logic.ti.com
Power Mgmt	power.ti.com
Microcontrollers	microcontroller.ti.com
RFID	www.ti-rfid.com
OMAP Applications Processors	www.ti.com/omap
Wireless Connectivity	www.ti.com/wirelessconnectivity

Applications

Automotive and Transportation	www.ti.com/automotive
Communications and Telecom	www.ti.com/communications
Computers and Peripherals	www.ti.com/computers
Consumer Electronics	www.ti.com/consumer-apps
Energy and Lighting	www.ti.com/energy
Industrial	www.ti.com/industrial
Medical	www.ti.com/medical
Security	www.ti.com/security
Space, Avionics and Defense	www.ti.com/space-avionics-defense
Video and Imaging	www.ti.com/video

TI E2E Community

e2e.ti.com