

Mosaic Core Specification

Core Number: C312NPX		Starter Kit Number: S312NPX		Rev. 3	11/05/2021
Product Specifications:		Description			
Microbolometer	Uncooled Vanadium Oxide				
Pixel Pitch	12 Microns				
Spectral Response	7.8 - 14 Microns				
Sensor Resolution (Array Format)	320 (h) x 240 (v); 76,800 pixels				
Frame Rate	Fast Frame - up to <32Hz				
Non-Uniformity Correction (NUC)	Automatic NUC (with shutter)				
Video Output Interfaces	USB				
Power:					
Power Requirement	3.3-5.0V, <50mW (Core only), 300mW (Core + Coprocessor Board)				
Optical & Mechanical:					
Focal Length	2.2mm EFL				
F-number (Focal Length/aperture)	f/1.05				
Spatial Resolution (IFOV, center)	5.23				
Field of View (FOV)	105° Horizontal x 75° Vertical				
Detection Range	186m (based on Johnson Criteria)				
Recognition Range	46m (based on Johnson Criteria)				
Identification Range	27m (based on Johnson Criteria)				
Distance to Spot Ratio	31:1				
Core Size/ Core Weight	10mm x 20mm x 21mm			Core Weight: 8 g	
Seek Software Development Kit:					
Supported Platforms	USB: Seek Linux, Windows, & Android SDK				
Output Formates (User selectable)	Linux / Windows SDK		Android SDK		
	16-bit filtered pre AGC		16-bit filtered pre AGC		
	32-bit ARGB post colorization.		32-bit ARGB post colorization in the bitmap image.		
	32-bit floating point or 16-bit fixed point		32-bit floating point or 16-bit fixed point thermography		
Imaging Specifications:		Calibrated Output in °C, °F, K			
Imaging Range	-40°C to +330°C at ambient operating temprature				
Thermography Accuracy	Thermal Image only. No temperature specification				
Sensor Sensitivity	65 mK (typical), <100 mK (max) @ 25°C				
Emmissivity	Factory default emissivity is set to 0.97. Emissivity is adjustable using the SDK.				
Environmental Conditions:					
Operating Temperature Range	-10°C to +60°C (-14°F to 140°F)				
Storage Temperature Range	-40°C to +80°C (-40°F to 176°F)				
Solar Protection	Yes				
Humidity	10%~95%RH, non-condensing				
Regulatory	ROHS, WEEE, REACH				
Accessories:					
Cushion	Yes	<p>Provided by Seek or receive design files for integration into other electronics</p>			
Bracket	Yes				
Sensor Flex	Yes				
Coprocessor Board	Yes				
USB Flex	Yes				
Customer Responsibilities:					
IP Rating	N/A				
Shock/Vibe	Customer responsibility with proper integration into final product housing				

THIS DRAWING COVERS
THE FOLLOWING SKUS:

- C2*2*
- C3*2*
- S2*2*
- S3*2*

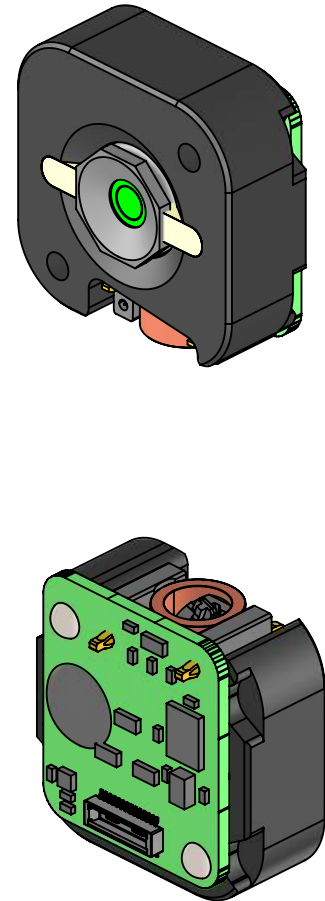

NO COPROCESSOR BOARD

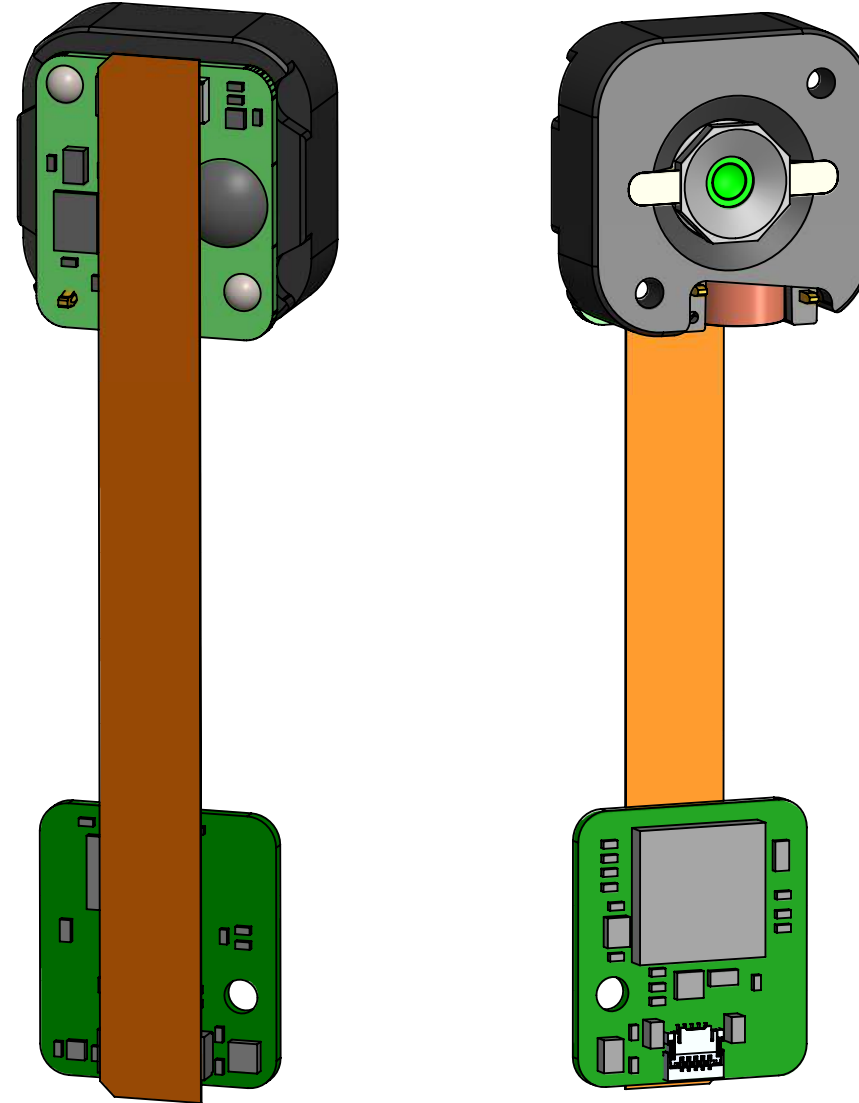

"P" OPTION WITH COPROCESSOR BOARD



NOTES:

1. SEE 3D CAD FILE FOR FULL GEOMETRY.
2.  KEYPPOINT FOR SHUTTER CLEARANCE.
3.  LENS ADHESIVE DOES NOT EXTEND ABOVE FRONT FACE.
2. THIS DESIGN IS NOT IPxx RATED.
5.  ADHESIVE BUMP PRESENT ON <9Hz CORES.
3. COPROCESSOR BOARD AND FLEX INCLUDED WITH "P" OPTION CORES.

MATERIAL	SEE NOTES	DRAWN	DLM	27MAR2019
FINISH	SEE NOTES	APPR.		
UNLESS OTHERWISE SPECIFIED: DIMENSIONS ARE IN MM (IN) IN ACCORDANCE WITH ASME Y14.5-2009		THIRD ANGLE PROJECTION		
GENERAL TOLERANCES 0.5 TO 6 ±0.1 [.004] > 6 TO 30 ±0.2 [.008] > 30 TO 120 ±0.2 [.008] > 120 TO 400 ±0.3 [.012] ANGLES ±1°		THE INFORMATION CONTAINED IN THIS DRAWING IS THE SOLE PROPERTY OF SEEK THERMAL. ANY REPRODUCTION IN PART OR AS A WHOLE WITHOUT WRITTEN PERMISSION IS PROHIBITED.		



TITLE: DOC, INTERFACE CONTROL DRAWING, MECH, 2.2MM MOSAIC		
SIZE	DWG. NO.	REV
B	DOC_233	4
SCALE: 2:1		SHEET 1 OF 2

8 7 6 5 4 3 2 1

D
C
B
A

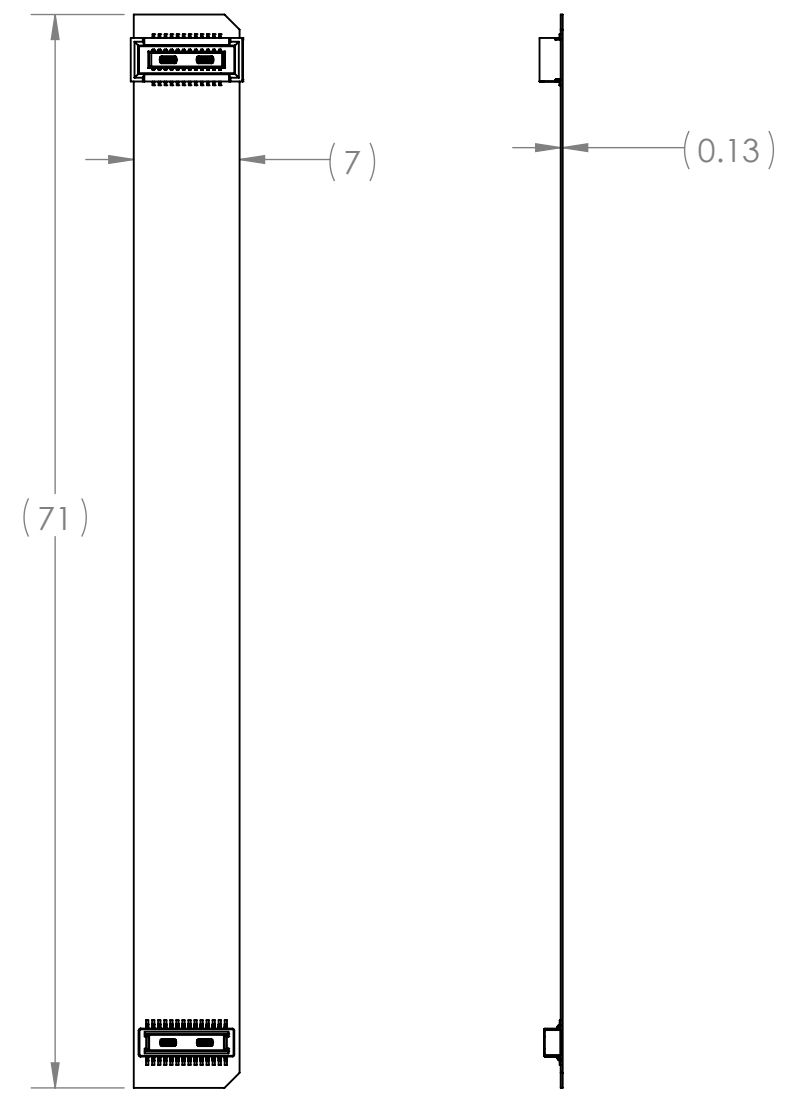

FLEX CABLE

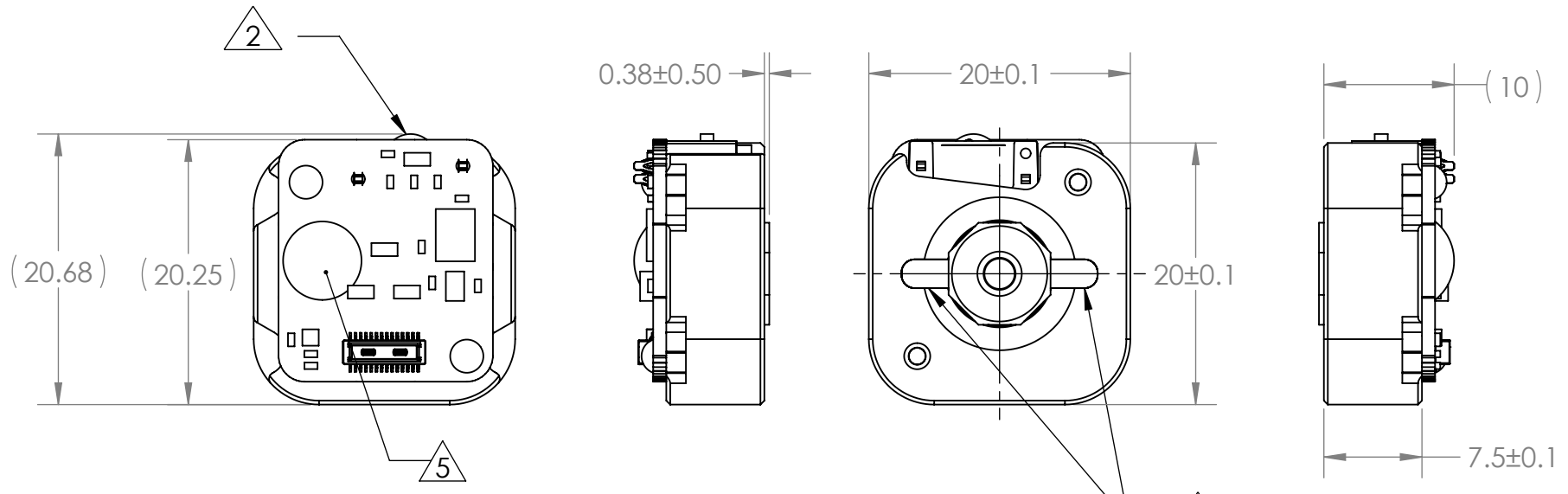

THERMAL IMAGING CORE

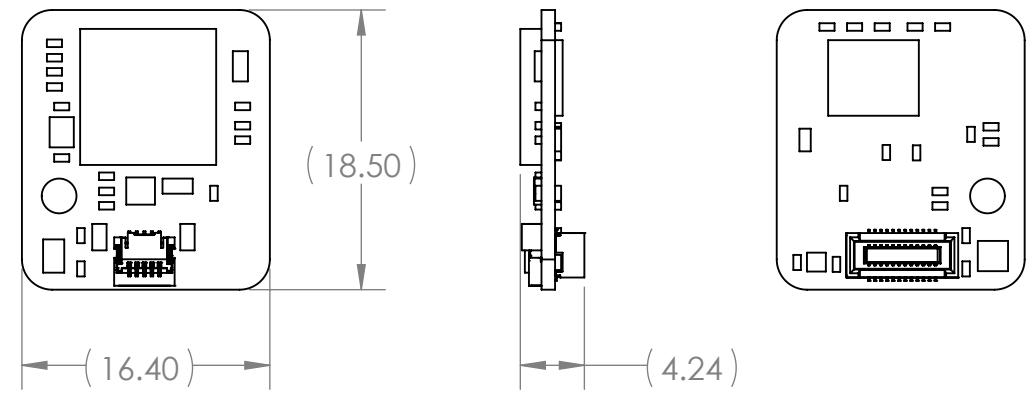

COPROCESSOR BOARD

THE INFORMATION CONTAINED
IN THIS DRAWING IS THE SOLE
PROPERTY OF SEEK THERMAL.
ANY REPRODUCTION IN PART OR
AS A WHOLE WITHOUT WRITTEN
PERMISSION IS PROHIBITED.

Seek[™]
thermal

TITLE: DOC, INTERFACE CONTROL
DRAWING, MECH, 2.2MM MOSAIC

SIZE	DWG. NO.	REV
B	DOC_233	4
SCALE: 2:1		SHEET 2 OF 2

8 7 6 5 4 3 2 1