

This drawing contains designs and other information which are the property of NEW ENGLAND INSTRUMENT COMPANY. Except for rights expressly granted by contract to the United States Government, this drawing may not, in whole or in part, be duplicated or disclosed or used for manufacture of the part disclosed herein, without the prior written permission of NEW ENGLAND INSTRUMENT COMPANY.

REVISIONS

LTR	ECO NUMBER	DATE	APPROVED
A	ECN-0513	4/17/73	Hughes
B	ECN-0567	6/12/73	Hughes
C	ECN-0683	12-11-73	RM
D	ECN-1961	9/9/76	APL
E	ECN-2244	76-12-29	D.F.
F	ECN-2562	7-5-77	RM
G	ECN-2627	9-6-77	J.T
H	ECN-2832	2-20-78	RM
J	ECN-2851	3-2-78	RM
K	ECN-3043	7-21-78	B.W.
L	ECN-8372	3-4-86	R.Hayma
M	ECN-9490	8-19-87	LMD
N	ECN-9751	7-6-88	MEH
P	ECN-11572	1-14-92	DB

1. SCOPE

1.1 Scope. This specification covers the detail requirements for a precision potentiometer, New England Instrument Co. (hereinafter called NEI) type number 34FL2-113, equivalent to General Electric Co., Avionic Controls Dept. 114D1369, Rev. K

2. APPLICABLE DOCUMENTS

2.1 The following document, of the issue in effect on the date of issue of the applicable NEI sales order forms part of this specification to the extent specified herein:

SPECIFICATIONS

NEW ENGLAND INSTRUMENT COMPANY
1216-0000
1-0020

3. REQUIREMENTS

3.1 General specifications. The potentiometers shall be as specified in NEI specification 1216-0000 except as modified or elaborated on herein. In the event of any conflict between this specification and the general specification, this specification shall govern.

UNLESS OTHERWISE SPECIFIED DIMENSIONS ARE IN INCHES	DRAWN V. Hughes	DATE 6/12/73	NEW ENGLAND INSTRUMENT COMPANY NATICK, MASSACHUSETTS	
TOLERANCES: FRACTIONS ± 1/64 DECIMALS ± .005 ANGLES ± 2°	CHECKED Tom	DATE 6/14/73	PRODUCT DEFINITION SPECIFICATION PRECISION POTENTIOMETER 34FL2-113	
MFG APPROVED, DATE	APPROVED Tom	DATE 6/14/73	SIZE A	CODE IDENT NO. 08015
Q.C. APPROVED, DATE	APPROVED FOR NEI D. Hughes	DATE 1973-06-14	DRAWING NUMBER 1216-0113-00	
SALES APPROVED, DATE	APPROVED FOR	DATE	SCALE:	SHEET 1 OF 6

3.2 GENERAL CHARACTERISTICS			QA CLASS	
			Requirement Source	
	CHARACTERISTICS	REQUIREMENT		AQL
1.	NO. OF CUPS	2	0	A
2.	NO. OF SECTIONS	2	0	A
3.	ELEMENT TYPE	Conductive Film	0	A
4.	BEARING TYPE	Ball	N	A
5.	MATERIAL - MOUNTING PLATE	Anodized aluminum	N	Q
6.	MATERIAL-HOUSING	Anodized aluminum	N	Q
7.	MATERIAL-SHAFT	Stainless Steel	N	Q
8.	WEIGHT	N/R	-	-

3.3 MECHANICAL PARAMETERS			QA CLASS	
			Requirement Source	
	PARAMETER	REQUIREMENT		AQL
1.	LATERAL RUNOUT	.001 T.I.R. max.	0	A
2.	PILOT SURFACE RUNOUT	.001 T.I.R. max.	0	A
3.	SHAFT RUNOUT	.001 T.I.R. max.	0	A
4.	END PLAY	.002 T.I.R. max.	0	A
5.	RADIAL PLAY	.001 T.I.R. max.	0	A
6.	STARTING TORQUE	0.35 oz.-in. max.	N	A
7.	RUNNING TORQUE	0.35 oz.-in. max.	N	A
8.	MOMENT OF INERTIA	N/R	-	-
9.	STATIC STOP STRENGTH	N/A	-	-
10.	DYNAMIC STOP STRENGTH	N/A	-	-
11.	MECHANICAL TRAVEL	360° continuous	0	A

LEGEND:

Requirement Source — N = NEI; O = OEM
 Q.A. Class — A = Acceptance Test;
 P = Preproduction Test; Q = Qualification Test

SIZE CODE IDENT NO.

A 08815

DRAWING NUMBER

1216-0113-00

SCALE:

REV 0

SHEET 2

3.4 ELECTRICAL AND ELECTROMECHANICAL PARAMETERS			QA CLASS		AQL
			Requirement Source		
	PARAMETER	REQUIREMENT			
1.	DIELECTRIC WITH-STANDING VOLTAGE	750 VRMS	0	A	
2.	INSULATION RESISTANCE	1000 Megohm min.	0	A	
3.	RESISTANCE - TEMPERATURE CHARACTERISTIC	500 PPM/°C max.	0	A	
4.	POWER RATING	10 milliwatt @ 110°C section 1 10 milliwatt @ 110°C section 2	0	A	
5.	EXCITATION FREQ. FOR AC CHARACTERISTICS	N/A	-	-	
6.	QUADRATURE VOLTAGE	N/A	-	-	
7.	PHASE SHIFT	N/A	-	-	
8.	CONFORMITY OF IN-PHASE COMPONENT	N/A	-	-	
9.	TOTAL INPUT IMPEDANCE	N/A	-	-	
10.	OUTPUT SMOOTHNESS	± 0.10% max.	N	A	
11.	Theoretical ELECTRICAL TRAVEL	251°	0	A	
12.	ELECTRICAL OVERTRAVEL	Section 1, 4° min. CW end, 15° min. CCW end Section 2, 0° min., both ends	0	A	
13.	MECHANICAL OVERTRAVEL	N/A	-	-	
14.	CONTINUITY TRAVEL	358° max.	-	-	
15.	INDEX POINT	On section 1 @ $\theta = 90^\circ$ Output ratio limits .26693/.27693	N	A	
16.	CONFORMITY DEFINITION	Absolute linearity	0	A	
17.	PHASING	Simultaneous conformity	0	A	
18.	TAP LOCATION	N/A	-	-	
19.	EFFECTIVE TAP WIDTH	N/A	-	-	
20.	BACKLASH	N/R	-	-	
21.	RESOLUTION	Virtually Infinite	N	A	
22.	MINIMUM VOLTAGE	N/A	-	-	
23.	END VOLTAGE	N/A	-	-	

SIZE	CODE IDENT NO.	DRAWING NUMBER
A	08815	1216-0113-00
SCALE:	REV: 0	SHEET 3

3.5 REQUIREMENTS OF INDIVIDUAL SECTIONS

3.5.1 Total Resistance

20 kohm \pm 10% each section

3.5.2 Function Characteristic

When measured as shown in the schematic below, the output ratio (e/E) shall conform to the characteristic shown below.

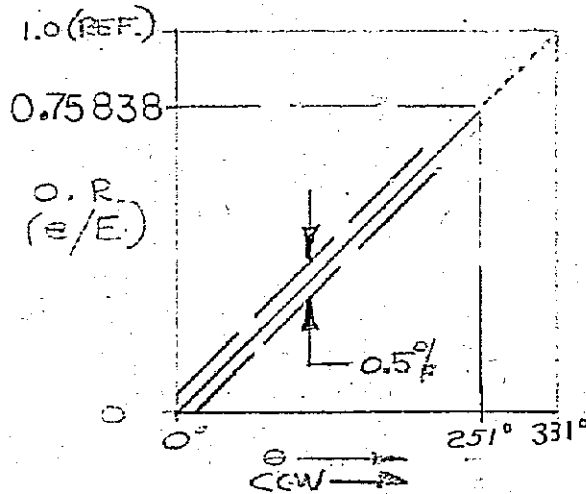

SECTION 1

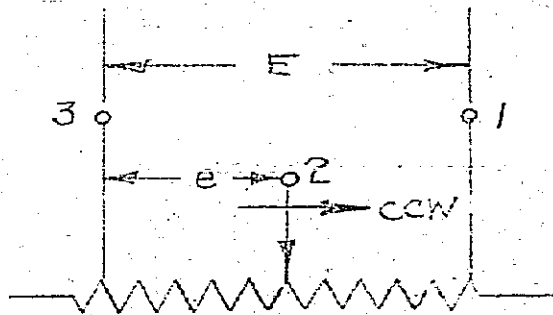

SECTION 2

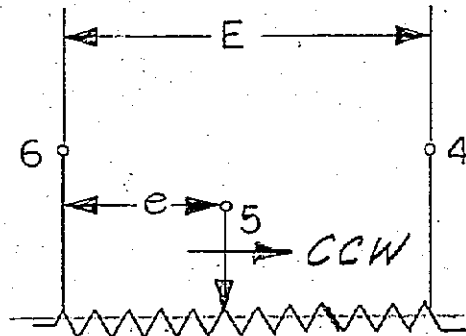

SIZE	CODE IDENT NO.	DRAWING NUMBER
A	08815	1216-0113-00
SCALE:	REV. P	SHEET 4

3.6. MARKING The potentiometer shall be permanently legibly marked as follows:

3.6.1 Unless otherwise specified below, the size and color of the marking shall be as follows:

- (A) size (height) - 3/64 min. 5/64 max.
- (B) color - white

3.6.2 The markings on the cylindrical surface of section 1 shall consist of the following:

- (A) Terminal identification (see fig. 1)
- (B) @ $\theta=90^\circ, 0$.
- (C) NEI logotype

3.6.3 The marking on the cylindrical surface of section 2 shall consist of the following:

- (A) 89954SOCN114D1369P108815-34FL2-113
- (B) Terminal identification
- (C) Serial number date code per 1-0020

3.6.4 Scribe line on shaft to be aligned with line on case within $\pm 10^\circ$ when wiper is at 90° .

FOTOBEAM/BROOKSIDE 165660

SIZE	CODE IDENT NO.	DRAWING NUMBER
A	08815	1216-0113-00
SCALE:	REV. P	SHEET 5

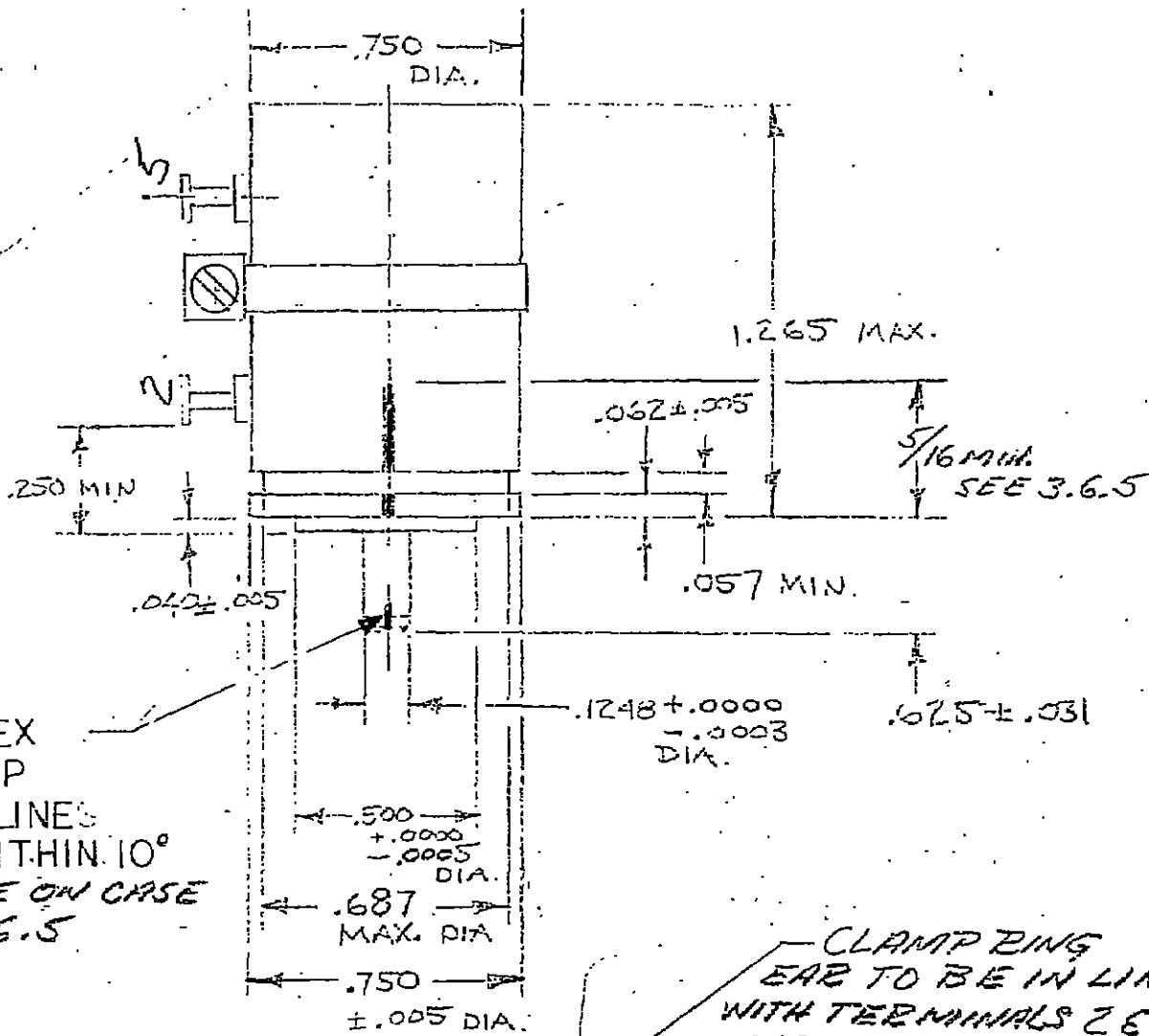

.015 WIDEX
.010 DEEP
SCRIBE LINES
TO BE WITHIN 10°
OF LINE ON CASE
SEE 3.6.5

CLAMP BING
EAR TO BE IN LINE
WITH TERMINALS 2 & 5
WITHIN $\pm 10^\circ$

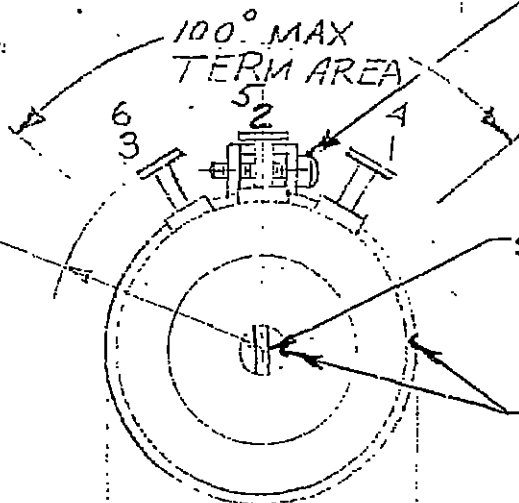

FIG. 1

VIEW ROTATED 90° TO
SHOW TERMINALS

SIZE	CODE IDENT NO.	DRAWING NUMBER
A	08815	1216-0113-00
SCALE:	REV. P	SHEET 6