

Data Sheet

Description

The Moonstone™ Tri-Color Power LED Light Source is a high-performance energy efficient device that can handle high thermal and high driving current. The exposed pad design enables excellent heat transfer from the package to the motherboard.

The low-profile package design is suitable for a wide variety of applications especially where height is a constraint.

The package is compatible with reflow soldering process. This provides more freedom and flexibility to the light source designer.

Applications

- Contour lighting
- Cove lighting
- Architectural lighting
- Garden lighting
- Decorative lighting
- Commercial lighting
- Mood lighting

Features

- Available in Tri-color.
- Energy efficient.
- Exposed pad for excellent heat transfer.
- Suitable for reflow soldering process.
- High current operation.
- Long operation life.
- Wide viewing angle.
- Silicone encapsulation.
- Non-ESD sensitive (threshold > 16 KV).
- MSL 5a products.

Specifications

- 3.5V (max) at 350 mA for InGaN
- 2.3V (max) at 350 mA for AlInGaP
- 120° viewing angle

Figure 1 Package Drawing

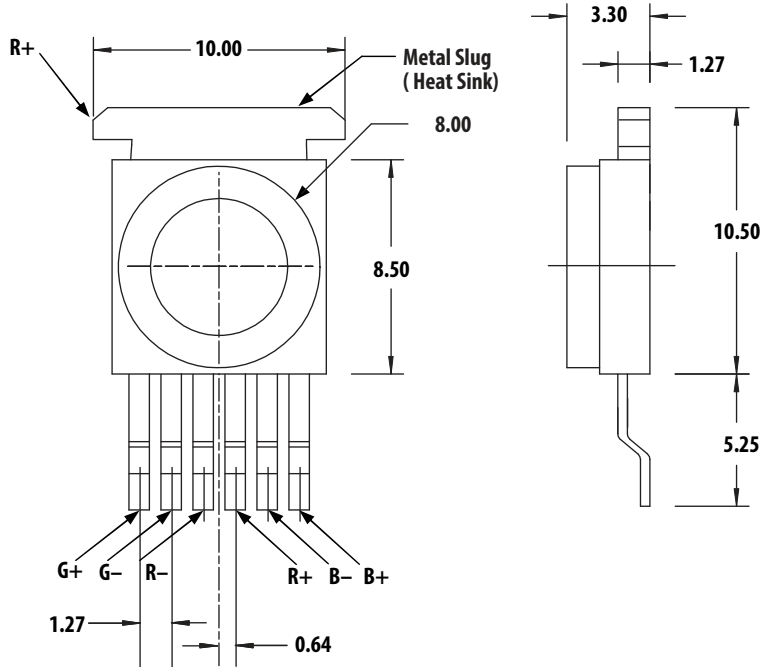

NOTE

1. All dimensions in millimeters.
2. Tolerance is ± 0.1 mm unless otherwise specified.
3. Metal slug is connected to the anode of Red.

Device Selection Guide ($T_J = 25^\circ\text{C}$)

Part Number	Color	Luminous Flux, Φ_V (lm) ^{a, b}			Test Current (mA)	Dice Technology
		Min.	Typ.	Max.		
ASMT-MT00	Red	33.0	40.0	56.0	350	AllInGaP
	Green	73.0	85.0	124.0		InGaN
	Blue	15.0	22.0	33.0		InGaN

- a. Luminous flux, Φ_V , is the total flux output as measured with an integrating sphere at 25-ms mono pulse condition.
 b. Flux tolerance is $\pm 10\%$.

Absolute Maximum Ratings

Parameter	AllnGaP	InGaN	Unit
DC Forward Current ^a	350	350	mA
Peak Pulsing Current ^b	1000	1000	mA
Power Dissipation	805	1225	mW
LED Junction Temperature	125	125	°C
Operating Metal Slug Temperature Range at 350 mA	-40 to +105	-40 to +105	°C
Storage Temperature Range	-40 to +120	-40 to +120	°C
Soldering Temperature	See Figure 11.		

- a. Derate linearly based on Figure 8 for InGaN and Figure 9 for AllnGaP.
 b. Pulse condition duty factor = 10%, frequency = 1 kHz.

Optical Characteristics at 350 mA ($T_J = 25^\circ\text{C}$)

Part Number	Color	Peak Wavelength, λ_p (nm)	Dominant Wavelength, λ_d (nm) ^a	Viewing Angle, $2\theta_{1/2}$ (°) ^b	Luminous Efficiency (lm/W)
		Typ.	Typ.	Typ.	Typ.
ASMT-MT00	Red	635	625	120	54
	Green	519	525	120	76
	Blue	454	460	120	12

- a. The dominant wavelength, λ_d , is derived from the CIE Chromaticity Diagram and represents the color of the lamp.
 b. $\theta_{1/2}$ is the off-axis angle where the luminous intensity is $1/2$ the peak intensity.

Electrical Characteristics at 350 mA ($T_J = 25^\circ\text{C}$)

Device Type	Forward Voltage, V_F (V) at $I_F = 350$ mA			Reverse Voltage, V_R (V) ^a	Thermal Resistance, $R_{\theta_{J-M5}}$ (°C/W) ^b
	Min.	Typ.	Max.		Typ.
AllnGaP	1.7	2.1	2.3	Not Recommended	23
InGaN	2.8	3.2	3.5		20

- a. Not designed for reverse bias operation.
 b. $R_{\theta_{J-M5}}$ is thermal resistance from LED junction to metal slug. All 3 colors are lighted simultaneously during measurement.

Figure 2 Relative Intensity vs. Wavelength

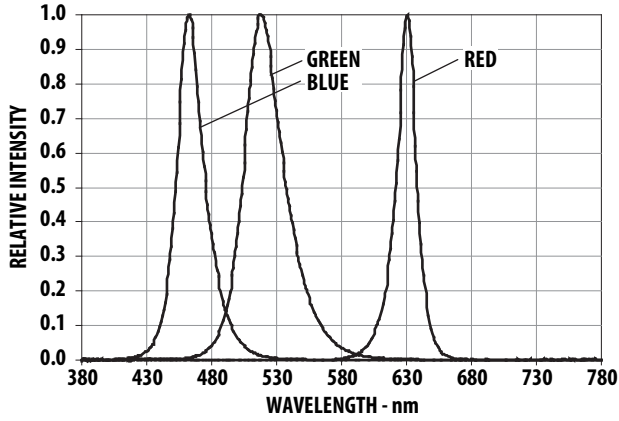

Figure 3 Relative Luminous Flux vs. Mono Pulse Current

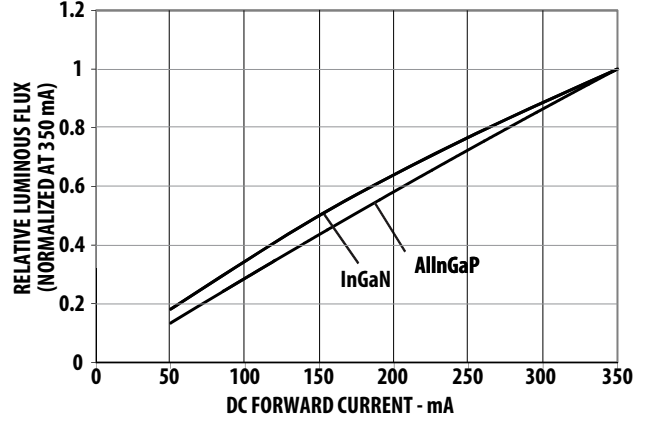

Figure 4 Forward Current vs. Forward Voltage

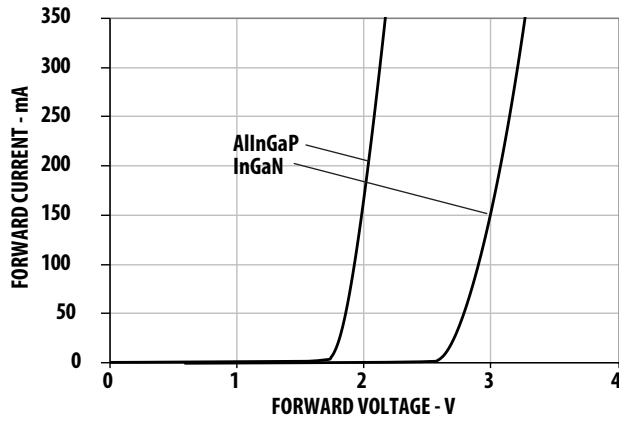

Figure 5 Radiation Pattern

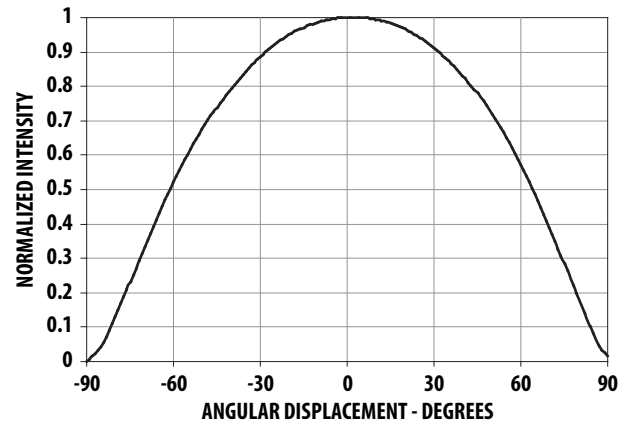

Figure 6 Forward Voltage Shift vs. Junction Temperature

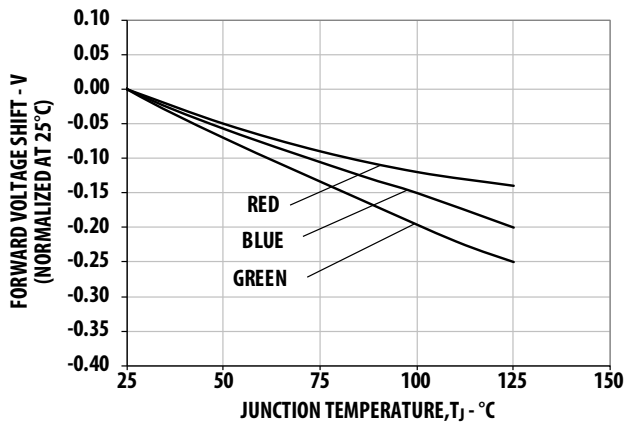

Figure 7 Relative Light Output vs. Junction Temperature

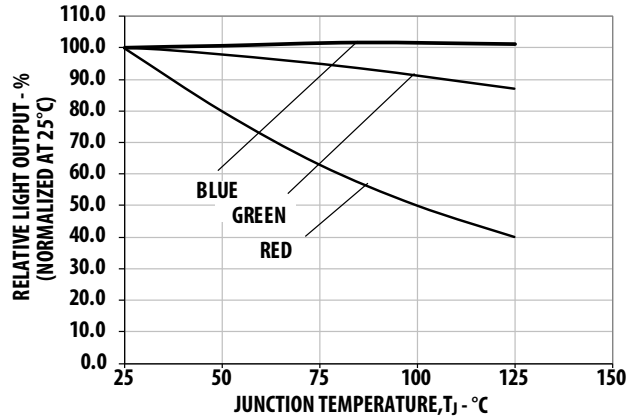

Figure 8 Maximum Forward Current vs. Ambient Temperature for InGaN (Derated based on $T_{JMAX} = 125^{\circ}C$, $R_{\theta J-A} = 30^{\circ}C/W$, $40^{\circ}C/W$, and $50^{\circ}C/W$)

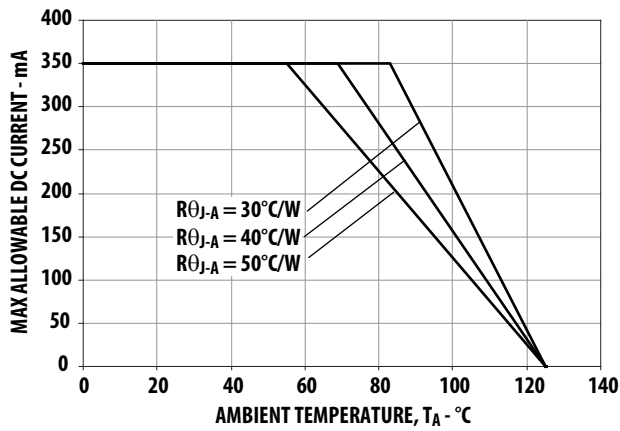

Figure 9 Maximum Forward Current vs. Ambient Temperature for AllnGaP (Derated based on $T_{JMAX} = 125^{\circ}C$, $R_{\theta J-A} = 30^{\circ}C/W$, $40^{\circ}C/W$, and $50^{\circ}C/W$)

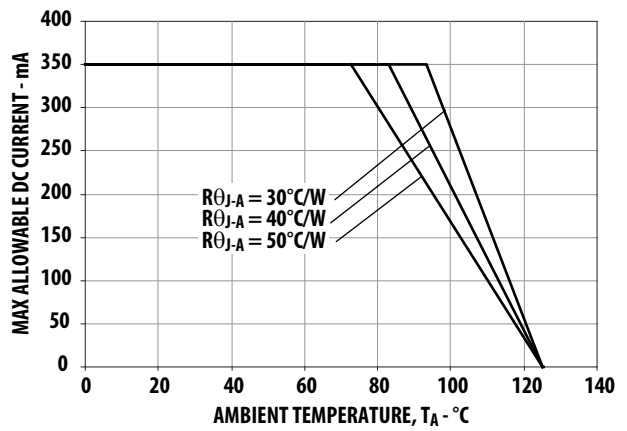

Figure 10 Maximum Forward Current vs. Metal Slug Temperature (Derated based on $T_{JMAX} = 125^{\circ}C$, $R_{\theta J-MS} = 20^{\circ}C/W$ for InGaN and $R_{\theta J-MS} = 23^{\circ}C/W$ for AllnGaP)

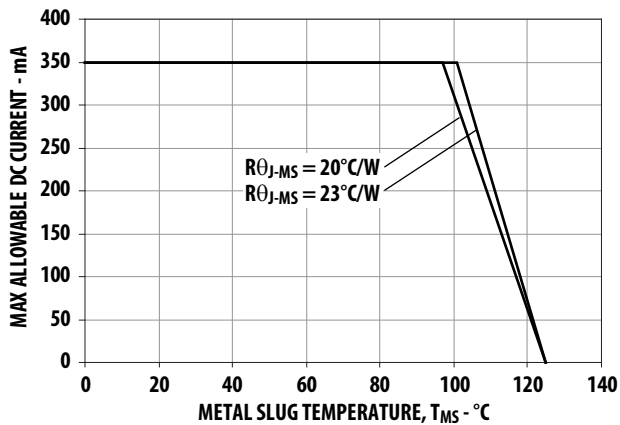
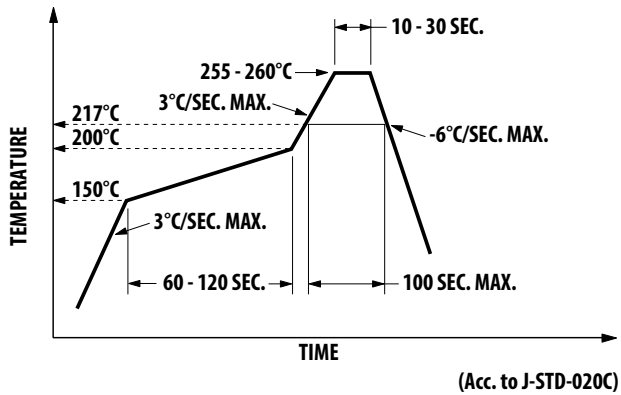
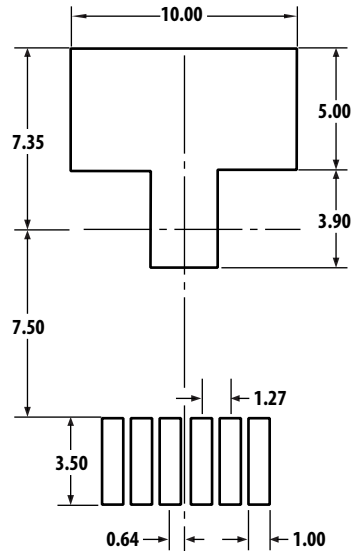

Figure 11 Recommended Reflow Soldering



NOTE For detail information on reflow soldering of Broadcom surface mount LEDs, refer to Broadcom Application Note AN1060, *Surface Mounting SMT LED Indicator Components*.

Figure 12 Recommended Soldering Land Pattern



Part Numbering System

A S M T - M T 0 0 - 0

X1	X2	X3	X4
----	----	----	----

Code	Description	Option
X ₁	Minimum Flux Bin	0 Full distribution
X ₂	Number of Flux Bins Starting from x ₁	0 Full distribution
X ₃	Color Bin Selection	0 Red — Full distribution Green — Bins A, B, C, or D Blue — Bins A, B, C, or D
X ₄	Packaging Option	1 Tape and Reel

Bin Information

Flux Bin Selection (x_1, x_2)

Individual reel contains the part from 1 bin only.

x_1	Minimum Flux Bin		
	Red	Green	Blue
0	Full Distribution		
A	H	L	E

x_2	Number of Flux Bins Starting from Selected x_1		
	Red	Green	Blue
0	Full Distribution		
A	2	2	2
B	2	2	3
D	2	3	3

Color Bin Selection (x_3)

Individual reel contains the part from 1 bin only.

x_3	Color Bin Combination		
	Red	Green	Blue
0	Full Distribution	A, B, C, and D	A, B, C, and D

Packaging Option (x_4)

Selection	Option
1	Tape and Reel

Flux Bin Limit

Bin ID	Luminous Flux (lm) at $I_F = 350$ mA	
	Min.	Max.
A	5.5	7.0
B	7.0	9.0
C	9.0	11.5
D	11.5	15.0
E	15.0	19.5
F	19.5	25.5
G	25.5	33.0
H	33.0	43.0
J	43.0	56.0
K	56.0	73.0
L	73.0	95.0
M	95.0	124.0

Tolerance for each bin limits is $\pm 10\%$.

Color Bin Limit

Color	Bin ID	Min.	Max.
Red	Full Distribution	620.0	635.0
Green	A	515.0	520.0
	B	520.0	525.0
	C	525.0	530.0
	D	530.0	535.0
Blue	A	455.0	460.0
	B	460.0	465.0
	C	465.0	470.0
	D	470.0	475.0

Tolerance: ± 1 nm.

Example:

ASMT-MT00-00001

- $x_1 = 0$ — Full Distribution
- $x_2 = 0$ — Full Distribution
- $x_3 = 0$ — Red (Full Distribution),
Green (A, B, C, and D),
Blue (A, B, C, and D)
- $x_4 = 1$ — Tape and Reel Option

Figure 13 CIE 1931 Chromaticity Diagram

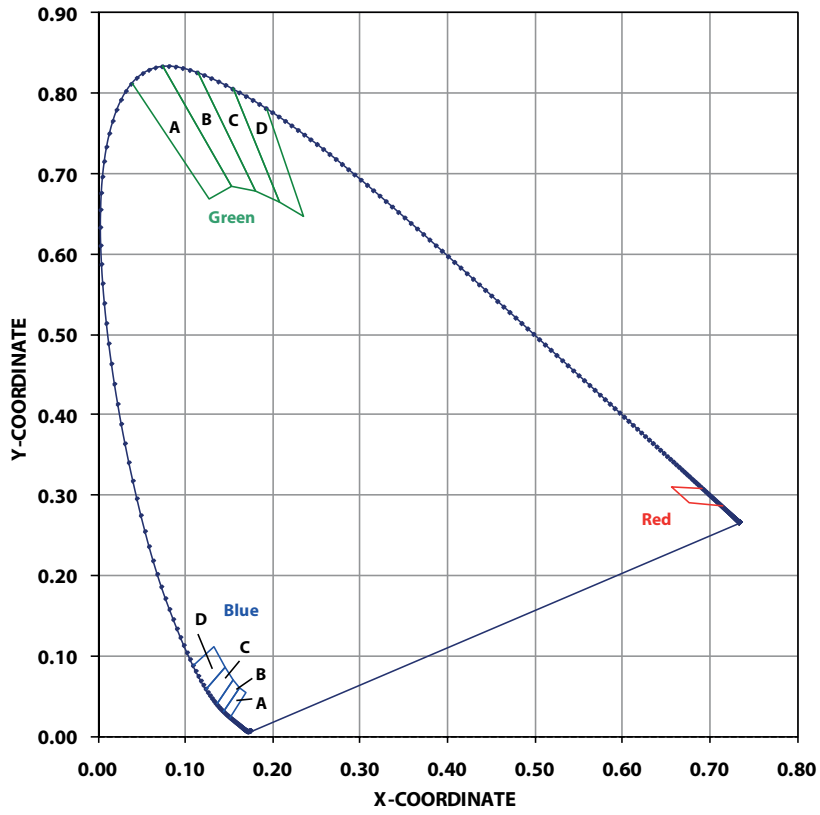

Tape and Reel — Option 1

Figure 14 Carrier Tape Dimensions

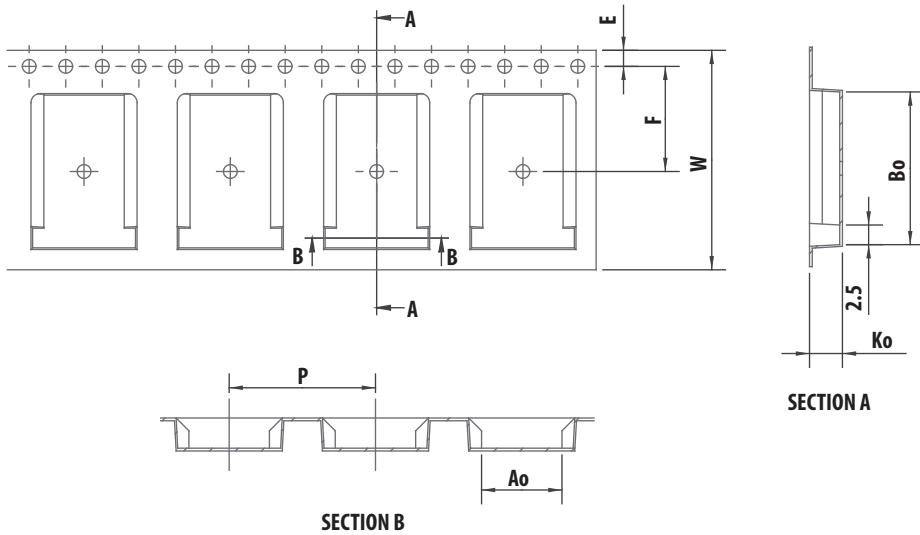

Dim	Value
A ₀	8.80 ± 0.10
B ₀	16.45 ± 0.10
K ₀	3.60 ± 0.1
E	1.75 ± 0.10
F	11.50 ± 0.10
W	24.0 ± 0.10
P	16.0 ± 0.10
Quantity/Reel	250 units

Note: All dimensions are in millimeters.

Figure 15 Carrier Tape Leader and Trailer Dimensions

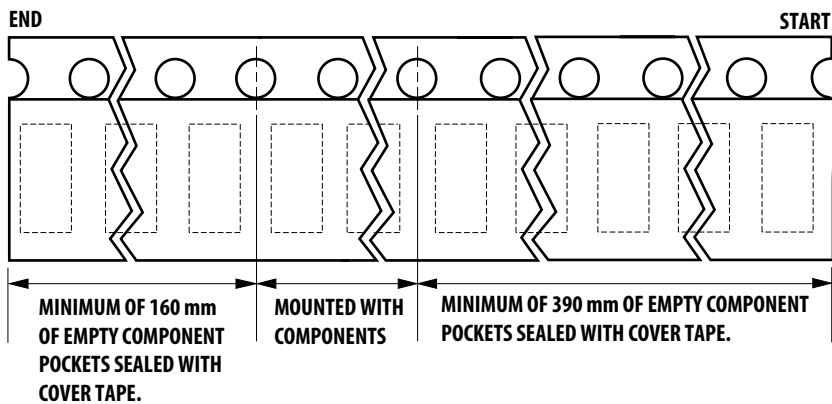
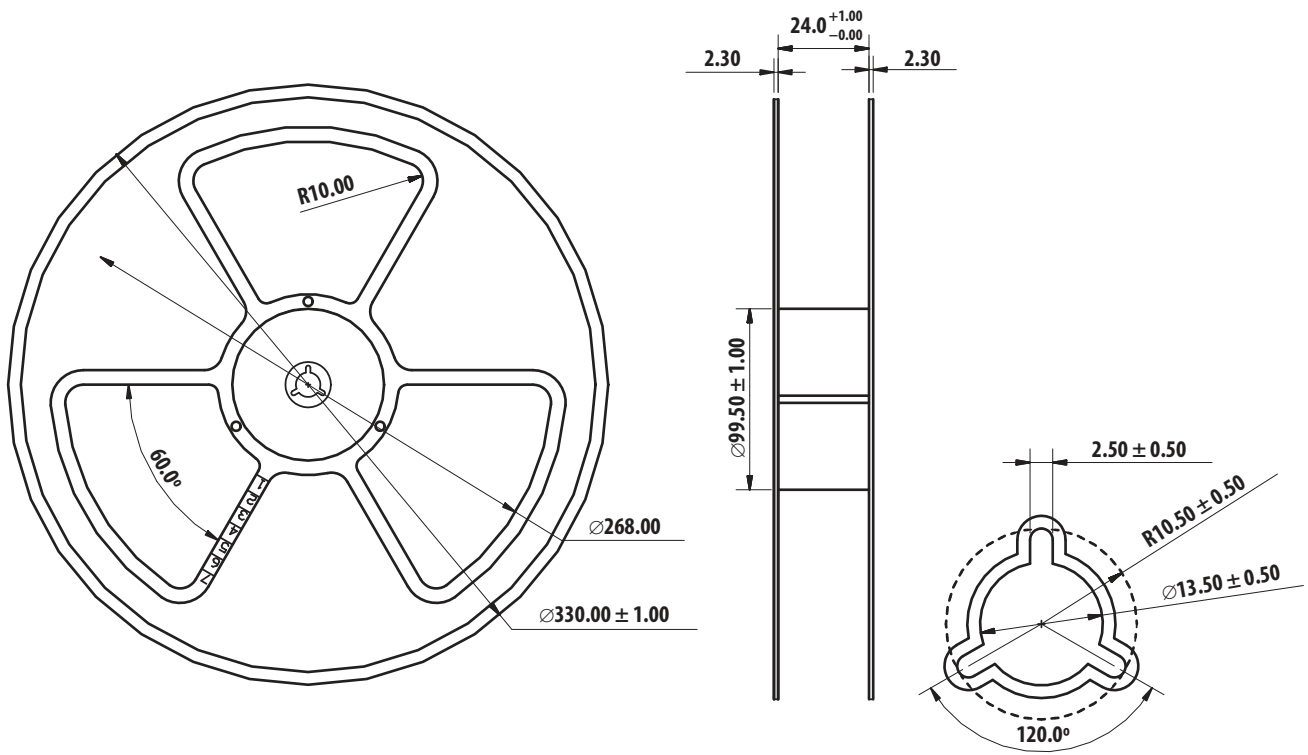

Figure 16 Reel Dimensions



Note: All dimensions are in millimeters.

Handling Precautions

The encapsulation material of the product is made of silicone for better reliability of the product. As silicone is a soft material, do not press on the silicone or poke a sharp object onto the silicone. This might damage the product and cause premature failure. During assembly or handling, the unit should be held on the body only. Refer to Broadcom Application Note AN5288 for detailed information.

Moisture Sensitivity

This product is qualified as Moisture Sensitive Level 5a per JEDEC J-STD-020. Precautions when handling this moisture sensitive product are important to ensure the reliability of the product. Refer to Broadcom Application Note AN5305, *Handling of Moisture Sensitive Surface Mount Devices* for details.

- Storage before use:
 - Unopened moisture barrier bag (MBB) can be stored at <math><40^{\circ}\text{C}</math>/90% RH for 12 months. If the actual shelf life has exceeded 12 months and the humidity indicator card (HIC) indicates that baking is not required, then it is safe to reflow the LEDs per the original MSL rating.
 - It is not recommended to open the (MBB) prior to assembly (e.g., for IQC).
- Control after opening the MBB:
 - The humidity indicator card (HIC) shall be read immediately upon opening of MBB.
 - The LEDs must be kept at <math><30^{\circ}\text{C}</math>/60% RH at all times, and all high temperature related processes including soldering, curing, or rework need to be completed within 24 hours.
- Control for unfinished reel:
 - Any unused LEDs need to be stored in sealed MBB with desiccant or desiccator at <math><5\%</math> RH.
- Control of assembled boards:
 - If the PCB soldered with the LEDs is to be subjected to other high temperature processes, the PCB needs to be stored in sealed MBB with desiccant or desiccator at <math><5\%</math> RH to ensure no LEDs have exceeded their floor life of 24 hours.
- Baking is required if:
 - HIC 10% indicator is not blue and 5% indicator is pink.
 - The LEDs are exposed to condition of $>30^{\circ}\text{C}$/60% RH at any time.
 - The LEDs floor life exceeded 24 hours.

Recommended baking condition: $60 \pm 5^{\circ}\text{C}$ for 20 hrs.

For product information and a complete list of distributors, please go to our web site: www.broadcom.com.

Broadcom, the pulse logo, Connecting everything, Avago Technologies, Avago, and the A logo are among the trademarks of Broadcom in the United States, certain other countries and/or the EU.

Copyright © 2005-2017 Broadcom. All Rights Reserved.

The term "Broadcom" refers to Broadcom Limited and/or its subsidiaries. For more information, please visit www.broadcom.com.

Broadcom reserves the right to make changes without further notice to any products or data herein to improve reliability, function, or design.

Information furnished by Broadcom is believed to be accurate and reliable. However, Broadcom does not assume any liability arising out of the application or use of this information, nor the application or use of any product or circuit described herein, neither does it convey any license under its patent rights nor the rights of others.

AV02-1693EN – April 12, 2017

