

### Solder Instruction b

1. Cable should be prepared for soldering. The cable/wires must be pretinned.
2. Insert cable/wire into solder cup.
3. Operate the soldering iron at 350°C, 50 Watt max. and use a pencil tip.
4. Put tip to wire in solder cup.
5. After 1 second bring in solder.
6. Heat for 3 seconds longer. Do not heat contact more than 4 seconds in total.
7. Remove soldering iron.
8. Wait until solder gets rigid again.
9. Do not solder adjacent contacts consecutively, alternate position within the connector to minimize heat build up.

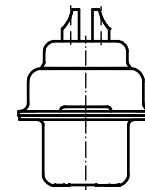
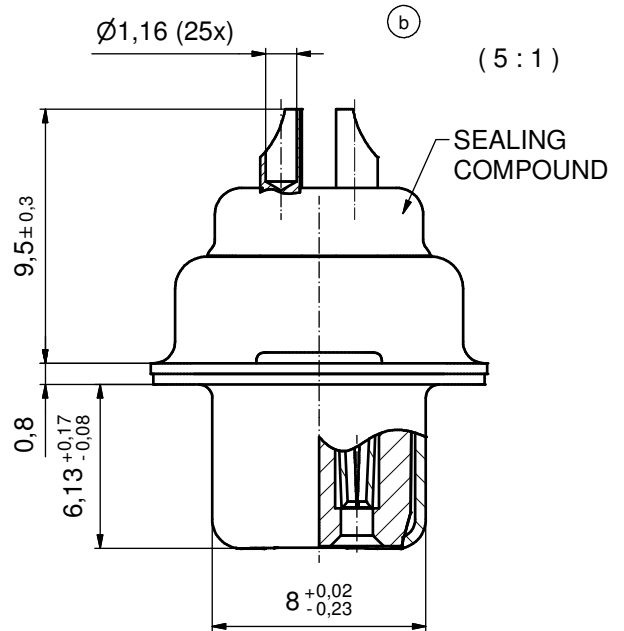
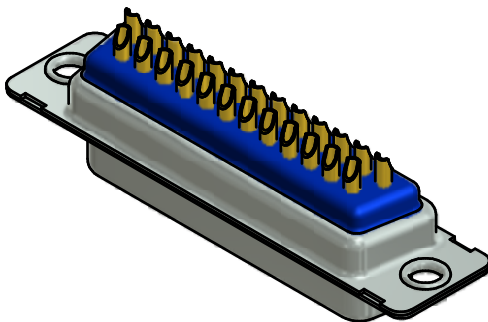
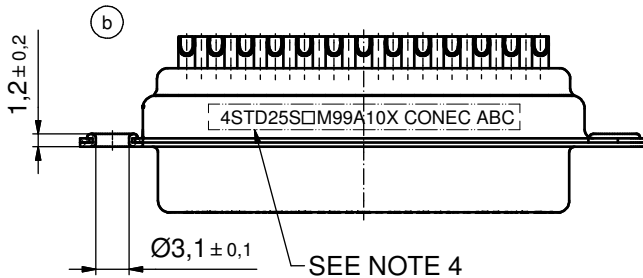
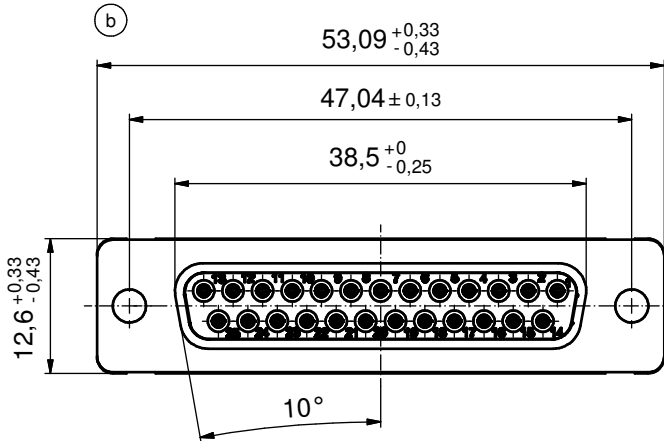

### NOTES:

1. METALSHELLS: COPPER ALLOY; min.315µin TIN over 40-80µin NICKEL
2. INSULATORS: PBT GF UL 94 V-0; BLACK
- b 3. CONTACTS: COPPER ALLOY; PLATING (SEE PART NO.):
  - PLEASE ADD C for 30µin HARD GOLD over min. 50µin NICKEL
  - PLEASE ADD B for 20µin HARD GOLD over min. 50µin NICKEL
  - PLEASE ADD A for GOLD FLASH over NICKEL (PREFERRED TYPE)
 SOLDER CUP ACCEPTS CABLE AWG 20
4. CONNECTOR IS PART MARKED: 4STD25S□M99A10X CONEC ABC (see note 3)

Directive 2002/95/EC RoHS compliant

THIS DRAWING MAY NOT BE COPIED OR REPRODUCED IN ANY WAY, AND MAY NOT BE PASSED ON TO A THIRD PARTY WITHOUT WRITTEN PERMISSION. OWNERSHIP AND COPYRIGHT OF CONEC GmbH DO NOT ALTER CAD DRAWING BY HAND				tolerance		scale: 2:1 (5:1)
				date	name	material: SEE NOTES
				drawn	03.08.12	Henneboel
				appd.	03.08.12	Fischer
				norm		
				d-old	18K11B2A/18K21B2A	
6 x b	Ä4411	03.08.2012	K.H.	title: <b>D-SUB FEMALE</b> 25pos. SOLDER CUP for installation into water resistant hood dwg no: <span style="border: 1px solid black; border-radius: 50%; padding: 0 2px;">b</span> DIN-A3 sh: 1		
a	Original					
rev.	description	date	name			
						part no: <span style="border: 1px solid black; padding: 0 2px;">b</span> 15K1A1111 (see note 3)