

NOTES:

1. MATERIAL:

HOUSING:HIGH TEMPERATURE THERMAL PLASTIC BLACK 30% GLASS FILLED,UL94V-0.
 GUIDE:HIGH TEMPERATURE THERMAL PLASTIC BLACK 30% GLASS FILLED,UL94V-0.
 TERMINAL: COPPER ALLOY
 SHELL: COPPER ALLOY

2.PLATING:

TERMINAL:CONTACT AREA 0.76MICROMETER GOLD PLATING AND SOLDER TAIL 1.27MIN. MICROMETER MATTE TIN
 UNDER PLATING 1-3 MICROMETER NICKEL PLATING OVERALL
 SHELL:1.27MIN. MICROMETER SOLDERABLE NICKEL PLATING OVERALL

3. PRODUCT COMPLANT TO ROHS DIERTIVE 2002/95/EC AND ELV DIRECTIVE 2000/53/EC 16.50 ±0.05

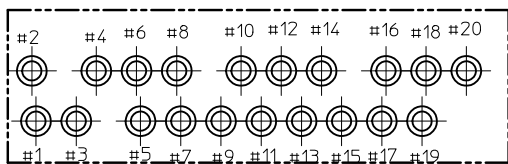
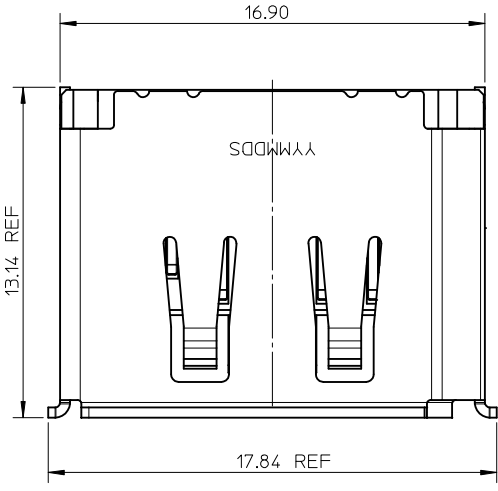

DETAIL 1

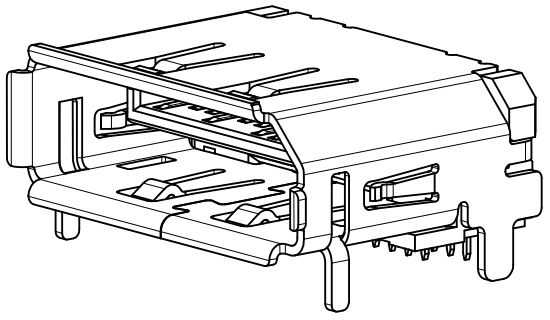
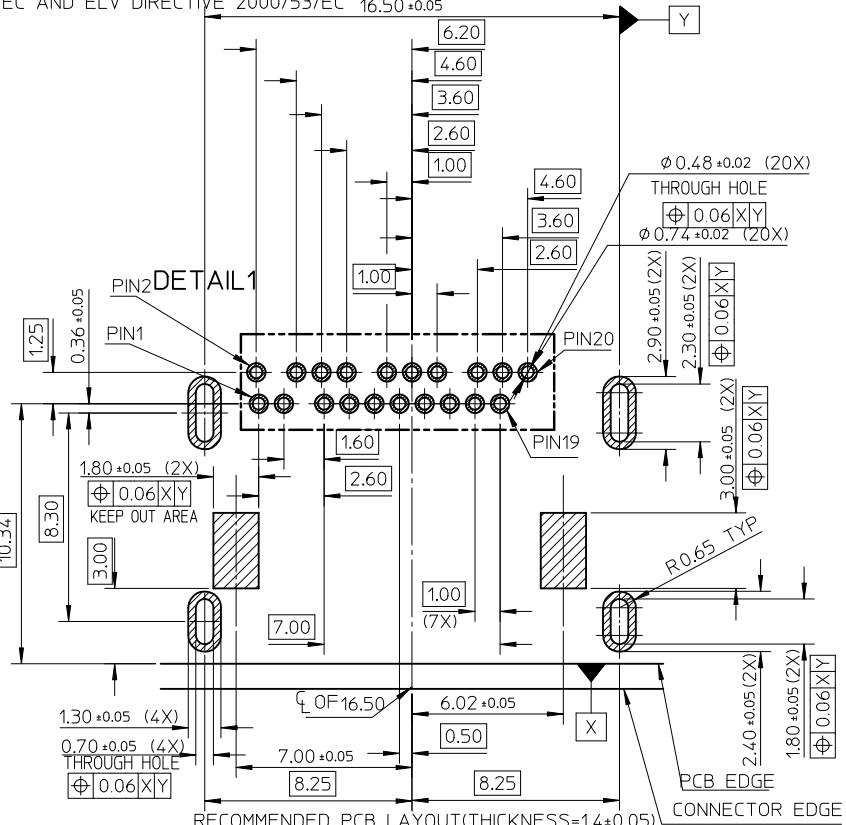
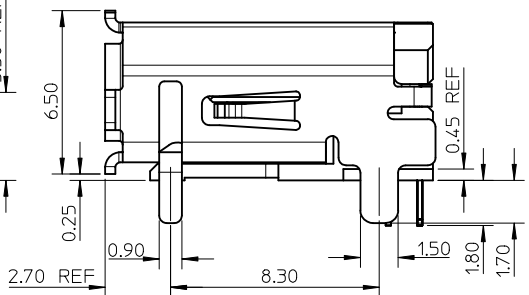
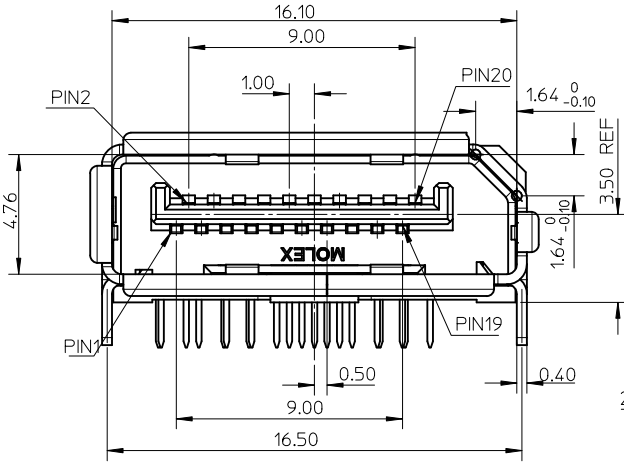

NEW RELEASE	EC NO: SH2010-0299	2010/01/19	QUALITY SYMBOLS
	DRW: HHE	2009/02/05	
	CHK: RZHANG	2010/02/26	
	APP: RZHANG		
A	REV	DESCRIPTION	<p>▽=0</p> <p>▽=0</p>

GENERAL TOLERANCES (UNLESS SPECIFIED)	
mm	INCH
4 PLACES	± --- ± ---
3 PLACES	± --- ± ---
2 PLACES	± 0.25 ± ---
1 PLACE	± 0.30 ± ---
ANGULAR ± 2 °	
DRAFT WHERE APPLICABLE MUST REMAIN WITHIN DIMENSIONS	

DIMENSION STYLE		SCALE	DESIGN UNITS	THIRD ANGLE PROJECTION
MM ONLY		5:1	METRIC	
DRAWN BY	DATE	TITLE		
HHE	2009/02/05	1.0MM PITCH REVERSE DIP DISPLAYPORT RECEPTACLE -LEAD FREE-		
CHECKED BY	DATE	MOLEX INCORPORATED		
RZHANG	2009/02/05	DOCUMENT NO. SD-105088-001		
APPROVED BY	DATE	SHEET NO. 1 OF 1		
RZHANG	2010/02/02			
MATERIAL NO. 105088-0001				

THIS DRAWING CONTAINS INFORMATION THAT IS PROPRIETARY TO MOLEX INCORPORATED AND SHOULD NOT BE USED WITHOUT WRITTEN PERMISSION