

P	LTR	DESCRIPTION	DATE	DWN	APVD
	B2	REVISED BY ECR-20-009210	09DEC2020	H. X	W. H

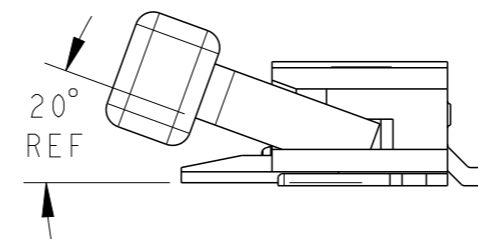

NOTES:

- 1 MATERIAL:
  - HOUSING : HIGH TEMP. THERMOPLSATIC, UL94 V-0
  - COLOUR : NATURAL
  - ACTUATOR : HIGH TEMP. THERMOPLSATIC, UL94 V-0
  - COLOUR : BLACK
  - CONTACT : COPPER ALLOY
  - SOLDER PEG : COPPER ALLOY
- 2 FINISH:
  - CONTACT :
  - UNDERPLATE : 1.27um MIN. NICKEL PLATING
  - OVERPLATE : 0.05um MIN SELECTIVE GOLD FLASH OVER CONTACT ON MATING AND SOLDER TAIL AREA.
- 3 SOLDER TAILS AND SOLDER PEG COPLANARITY : 0.1mm MAX
- 4. PACKAGING SPECIFICATION: TAPE AND REEL  
PRIMARY PACK QTY: 1800PCS/REEL
- 5. OBSOLETE PART: 1-1735842-2

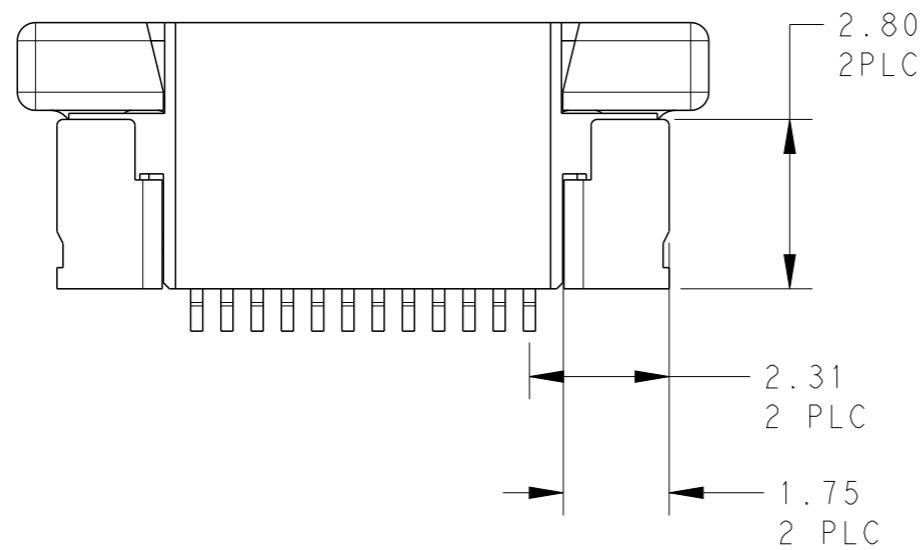
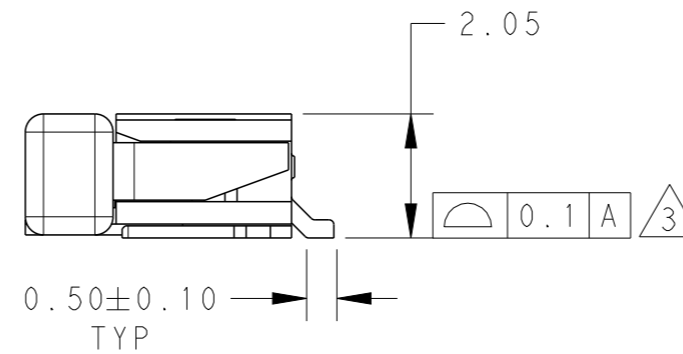
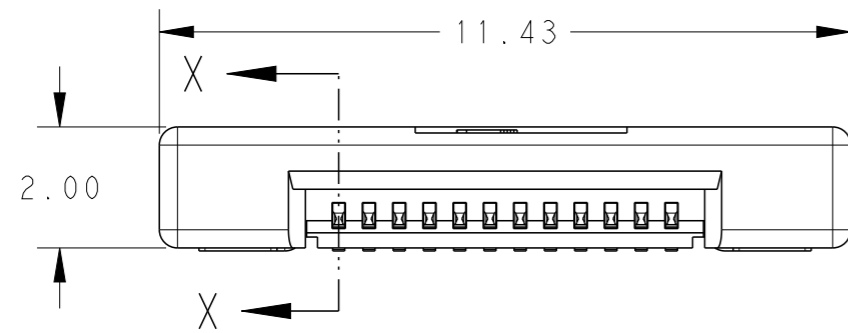
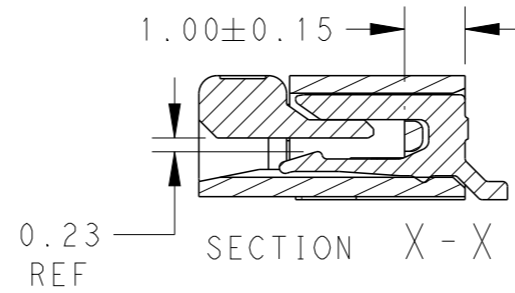
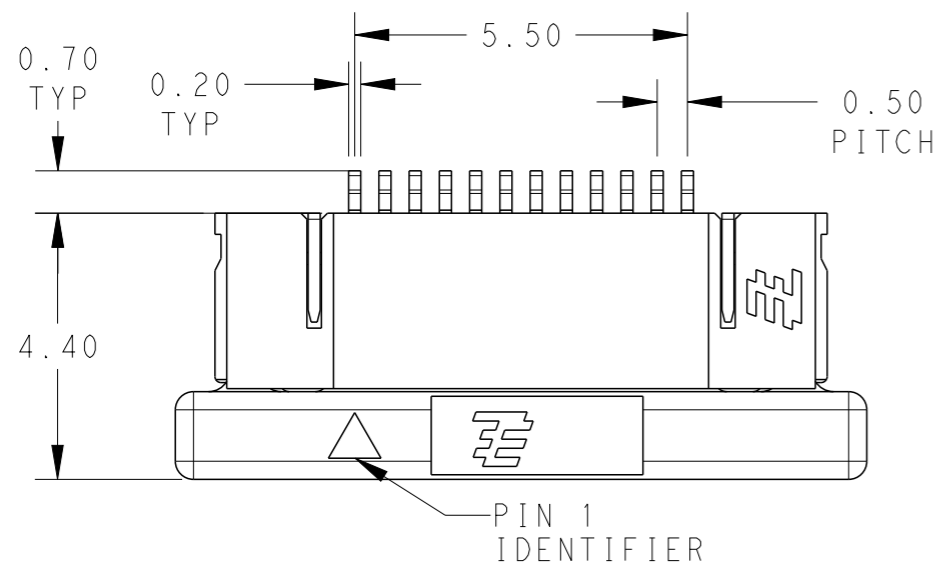
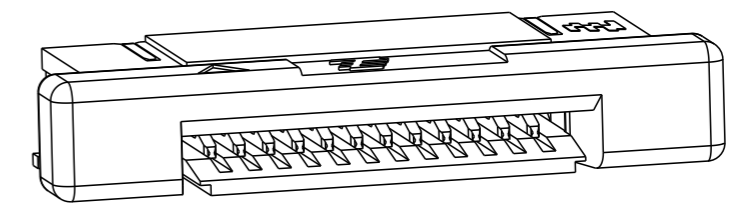

ISOMETRIC VIEW

1-1735842-2 AS SHOWN

THIS DRAWING IS A CONTROLLED DOCUMENT.		DWN	10MAR2010	TE Connectivity	
		CHK	10MAR2010		
		APVD	03MAY2010		
		NAME	SELFONG		
DIMENSIONS:		TOLERANCES UNLESS OTHERWISE SPECIFIED:		PRODUCT SPEC	
mm				108-51107	
		0 PLC ±-		APPLICATION SPEC	
		1 PLC ±0.1		-	
		2 PLC ±0.1		WEIGHT	
		3 PLC ±0.1		-	
		4 PLC ±-		A300779	
		ANGLES ±1°		C=1735842	
MATERIAL		FINISH		RESTRICTED TO	
-		-		-	
CUSTOMER DRAWING				SCALE	8:1
				SHEET	1 OF 3
				REV	B2

P	LTR	DESCRIPTION	DATE	DWN	APVD
		SEE SHEET 1			

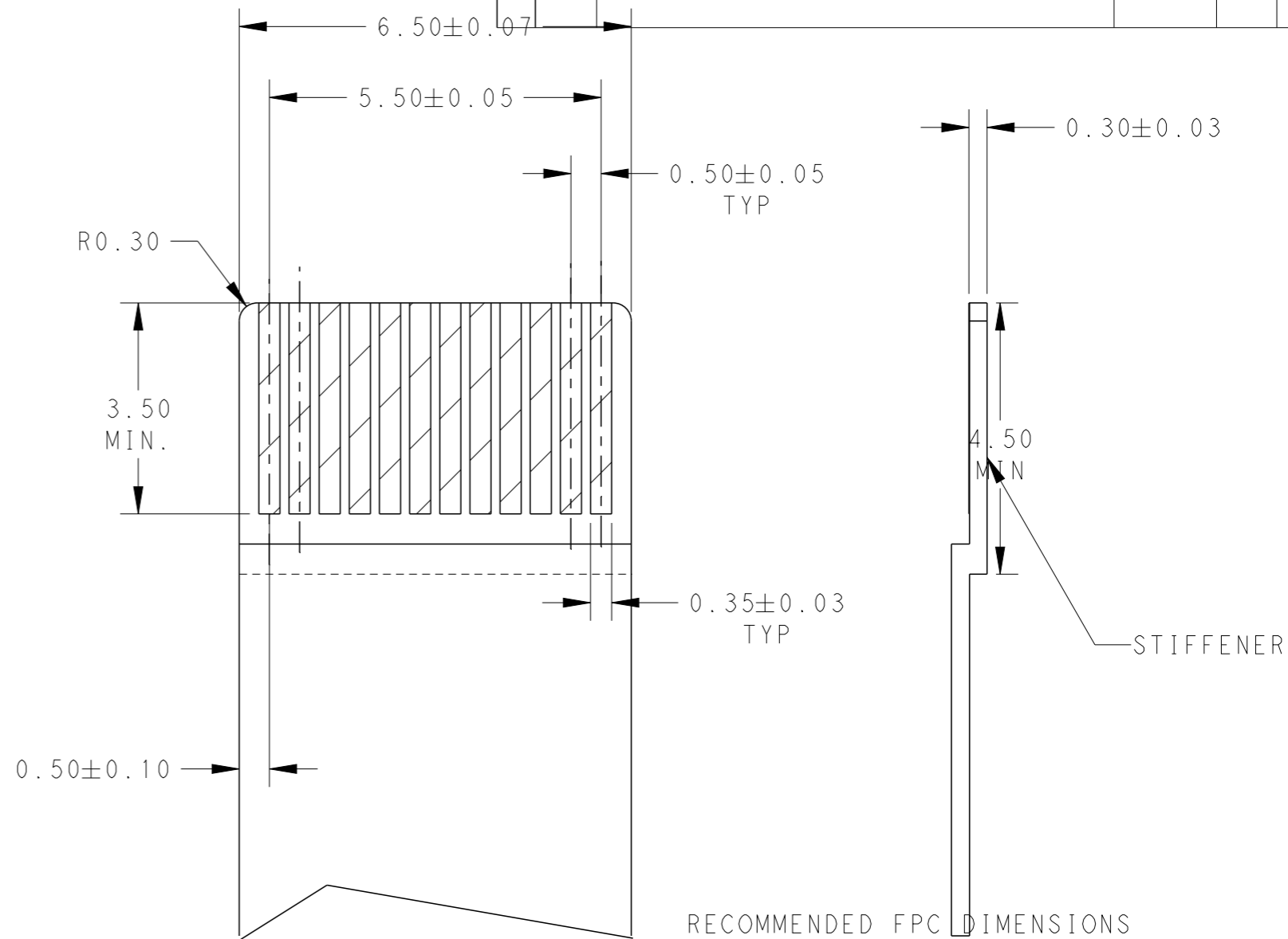
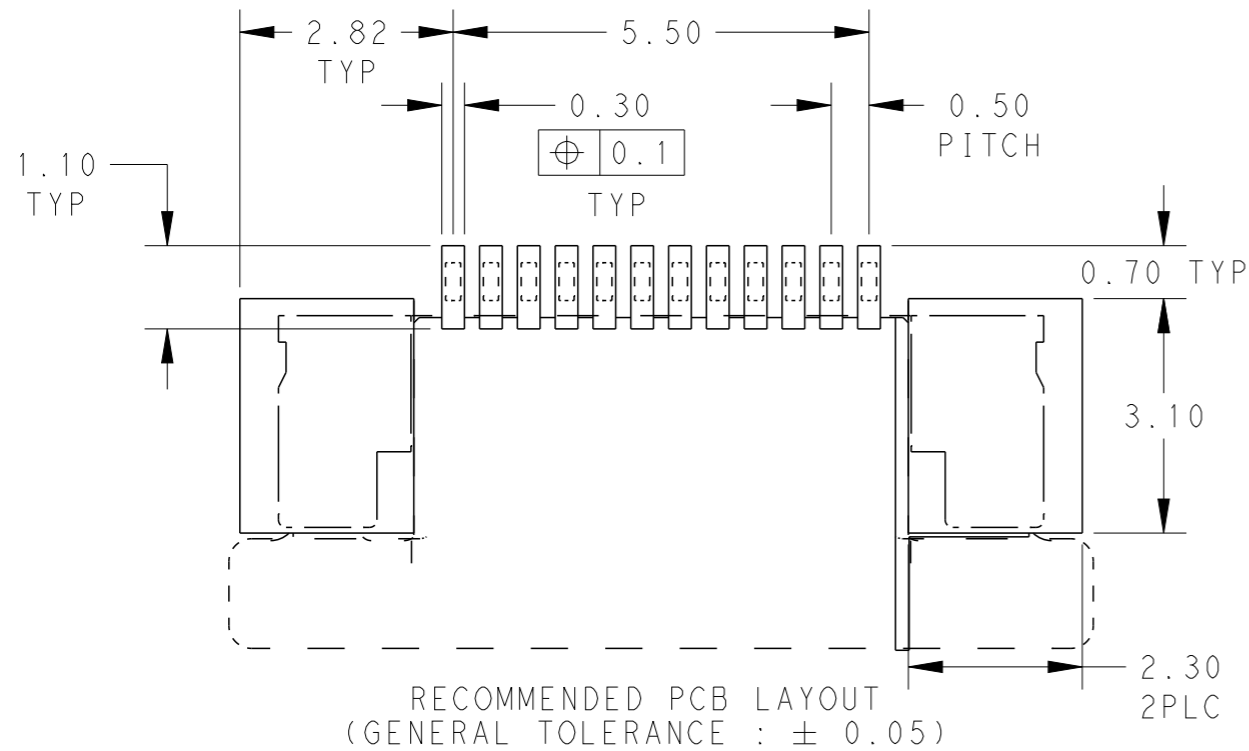

THIS DRAWING IS A CONTROLLED DOCUMENT.		DWN	10MAR2010		<b>STE</b> TE Connectivity
		CHK	10MAR2010		
		APVD	03MAY2010		
		NAME	SIFLEONG		
DIMENSIONS: mm		TOLERANCES UNLESS OTHERWISE SPECIFIED:		ASSEMBLY, 0.5mm PITCH FPC BOTTOM CONTACT, SMT TYPE	
		0 PLC ± -		SIZE	
		1 PLC ± 0.1		CAGE CODE	
		2 PLC ± 0.1		DRAWING NO	
		3 PLC ± 0.1		RESTRICTED TO	
4 PLC ± 0.1		4 ANGLES ± -		A3 00779C-1735842	
MATERIAL		FINISH		SCALE 8:1 SHEET 2 OF 3 REV B2	
				CUSTOMER DRAWING	

P	LTR	DESCRIPTION	DATE	DWN	APVD
		SEE SHEET 1			

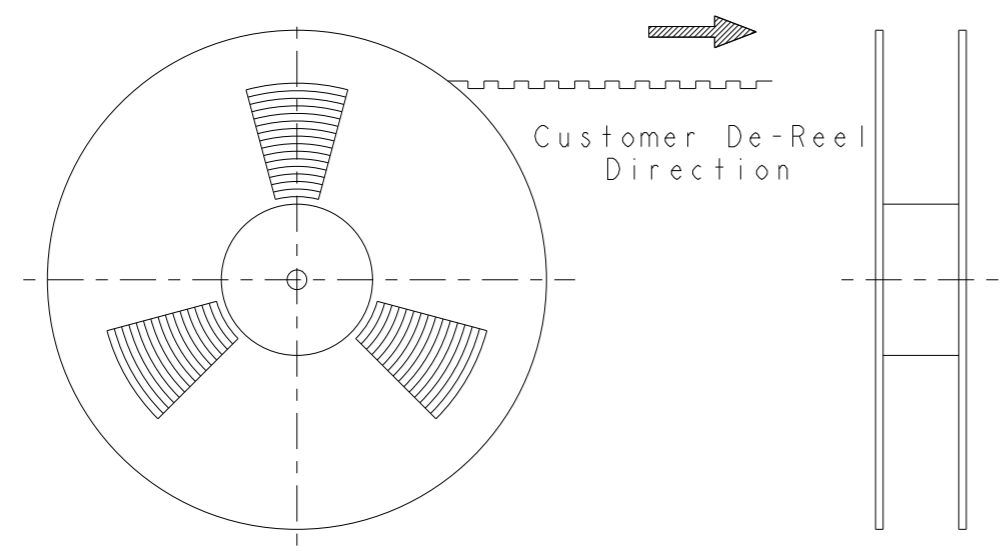
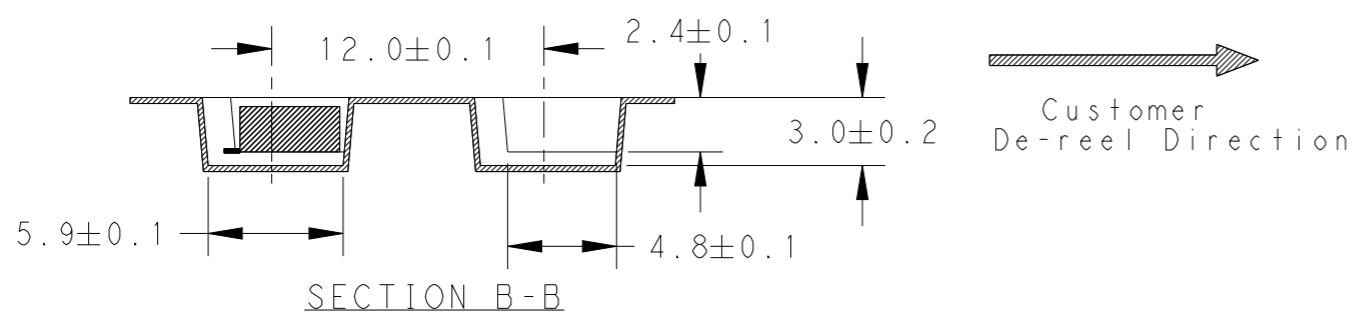
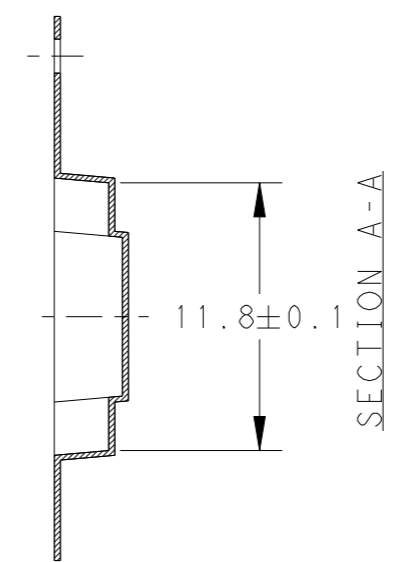
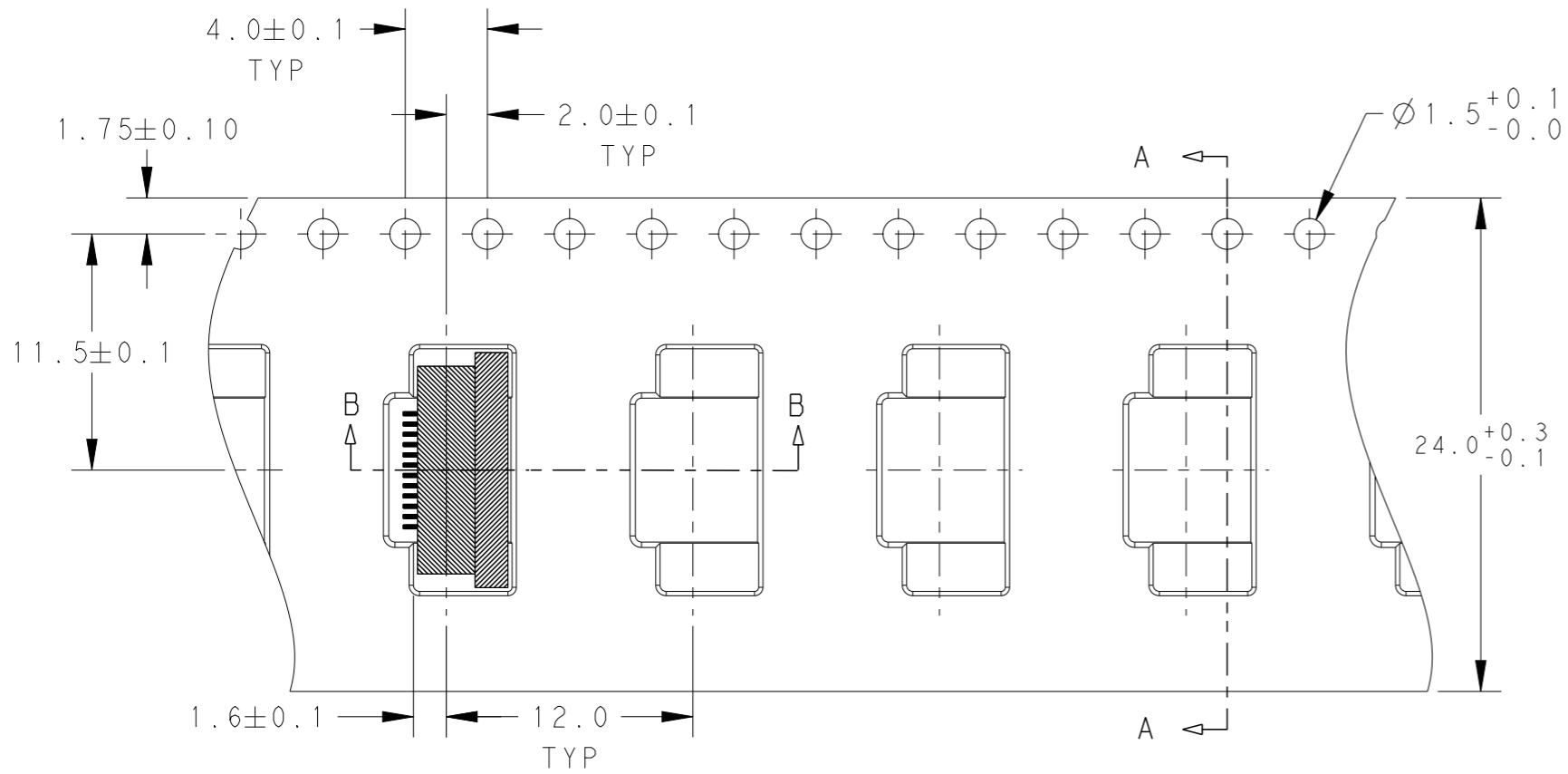

THIS DRAWING IS A CONTROLLED DOCUMENT.

DIMENSIONS: mm	TOLERANCES UNLESS OTHERWISE SPECIFIED:
	0 PLC ± -
	1 PLC ± 0.1
	2 PLC ± 0.1
	3 PLC ± 0.1
	4 PLC ± -
	ANGLES ± 1°
MATERIAL	FINISH
-	-

DWN	10MAR2010
VINCENT TAN	
CHK	10MAR2010
VINCENT TAN	
APVD	03MAY2010
SFLEONG	
PRODUCT SPEC	-
APPLICATION SPEC	-
WEIGHT	-
CUSTOMER DRAWING	

**STE** TE Connectivity

NAME: ASSEMBLY, 0.5mm PITCH FPC BOTTOM CONTACT, SMT TYPE

SIZE	CAGE CODE	DRAWING NO	RESTRICTED TO
A3	00779	C= 1735842	-

SCALE 8:1 SHEET 3 OF 3 REV B2