

ENG. NO. SD35426-9*02

EDP NO.

SIMILAR ITEM

PROJECT NO.

8 7 6 5 4 3 2 1

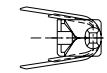
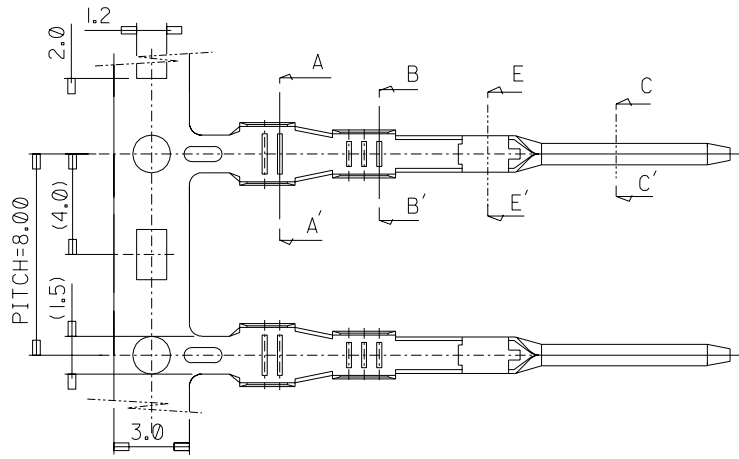

- NOTES
1. MATERIAL: BRASS(C2600R), T=0.20
 2. FINISH: PRE-TIN PLATE
 3. RECOMMENDED LENGTH OF WIRE STRIP: 3.5-4.0
 4. APPLICATION OF WIRE:
 - CAVS, CAVUS: 0.3-0.5sq (ø/1.1-1.7)
 - CAVUS: 0.85 sq (ø/1.5-1.6)

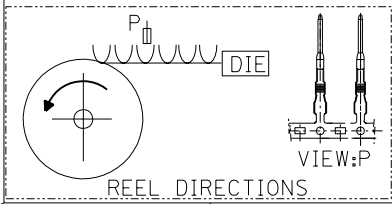
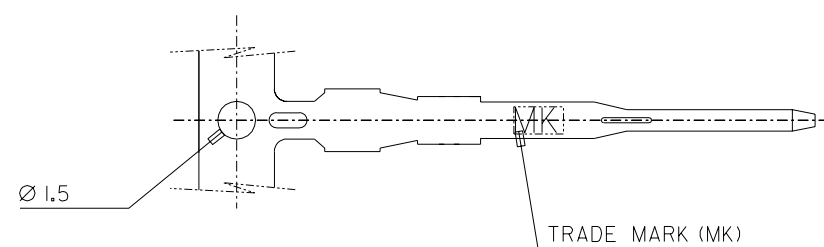
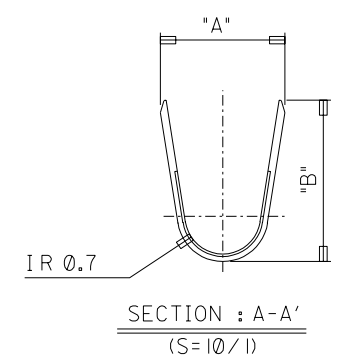
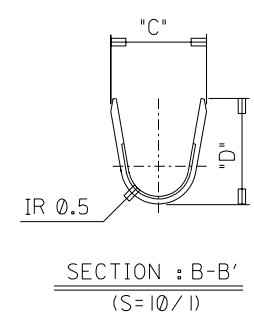
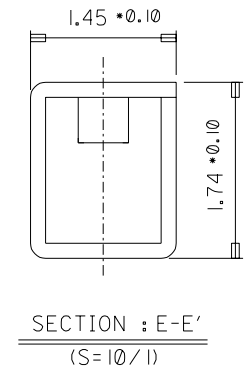
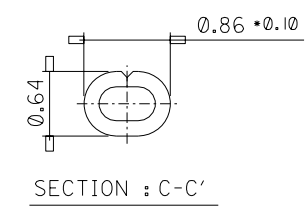
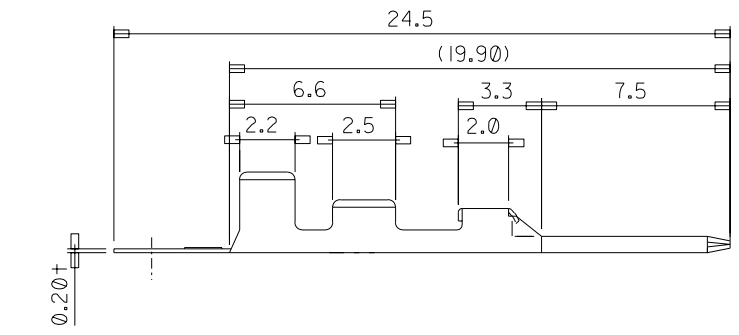

ENG NO.	A	B	C	D	WIRE SIZE
35426-9702	2.5	3.23	1.95	2.47	0.85sq.
35426-9602	2.5	3.23	1.95	2.15	0.3-05sq.

		MATERIAL		SEE NOTES		molex MOLEX-KOREA CO.,LTD.	
		GENERAL TOLERANCE		DIMENSION : 0.20		DRAWN BY CHOI	
		ANGLE :				CHK'D BY B.K.CHOI	
B	REVISED			97.12.11		APP'D BY	
A	NEW RELEASED			97.11.28		SCALE 5/1(10/1,20/1)	
LTR REVISION RECORD		ECN	DATE	ASS'Y PART		TITLE:	
				DESCRIPTION		DUOMATE MALE TER'L	
				ENG. NO.		SHEET	
				REVISE ONLY ON CAD SYSTEM		1/1	
						ENG. NO. SD35426-9*02	
						REV B	

F
E
D
C
B
S35426