

Mini Mighty Punch

Precision Punch for Professional Results

Cheval



Cheval Mini Mighty hand punch is an essential addition to every workshop.

- Stripper plate and back gauge to ensure precision punching.
- Heavy duty steel construction with tough scratch resistant powder coat finish.
- Easy to change and align punches.

Perfect companion to enable your work on our System SA and PF-19 enclosures.

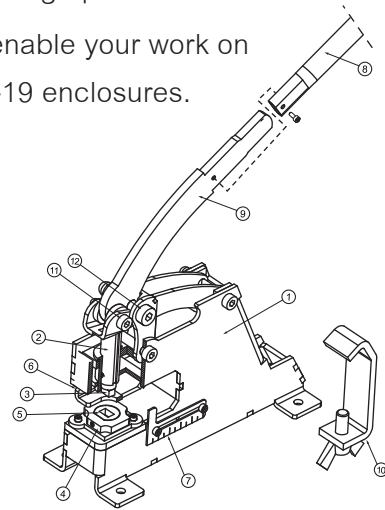

Part Number: ACCMMP1500

Specifications

Largest Tool Dimension

- Rectangle  5x10 mm
- Round  10 mm

Maximum Punch Force (P_m) 1,500 kgf

Maximum Materials Thickness (in mm.)*

Materials	Punch	
	Rectangle 3x7	Round 4.0
Aluminium	3.0	3.5
Zinc	2.5	3.0
Copper	1.6	2.5
Brass	1.6	2.5
Steel	1.2	1.8
Stainless Steel	0.9	1.2

* Based on punch sizes specified. Other punches can be used, refer to maximum materials calculation in Users Guide.













Overall Dimension (WxLxH)

- Mini Mighty Punch 72x89x148 mm
- Box 365x110x110 mm

Weight

- Net weight 1.7 kg
- Gross weight 2.2 kg

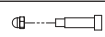
Contents of Kit

Item	Description	QTY.	Image
1	Mini Hand Punch Body	1	
2	Punch Holder	1	
3	Punch Tip 3.1 Rectangle 3x7 mm 3.2 Round 4.0 mm	2 1 1	
4	Die Holder	1	
5	Die 5.1 Rectangle 3x7 mm 5.2 Round 4.0 mm	2 1 1	
6	Stripper	1	
7	Back Gauge	1	
8	Handle Extension Tube	1	
9	Handle	1	
10	Table Clamp	1	
11	Pin 6 mm	1	
12	Pin 8 mm	1	

For more information about Mini Mighty Punch, please contact:
Cheval Electronic Enclosure Co., Ltd.
 Email: commce@chevalgrp.com Tel: +662 315 1504-5

www.chevalgrp.com