

# C-Clip Connector

Pulse Part Number W9909

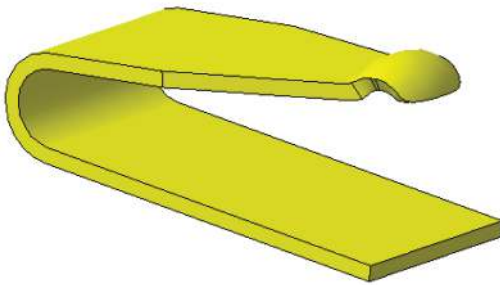

Ideal for board-to-antenna applications  
Spring contact for positive connection  
Surface mount technology; solder reflowable



### Features

- PWB Footprint 3.2 x 1.7 mm
- Tape & Reel Packaging
- RoHS Compliant Product

### Applications

- Antenna Contacts
- W3530 Antenna RF Contacts

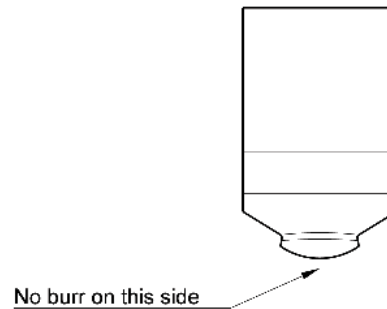
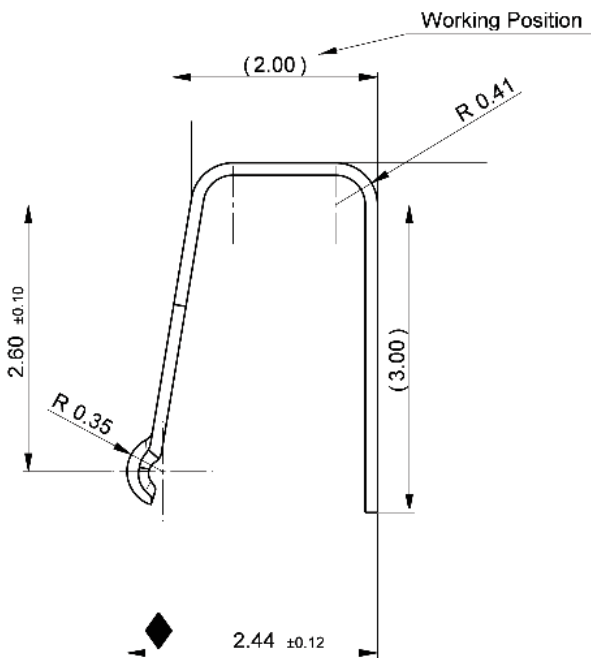

# C-Clip Connector

Pulse Part Number W9909

## W9909 C-Clip Configuration and Dimensions

PWB Pad Dimensions and C-Clip Position for W9909

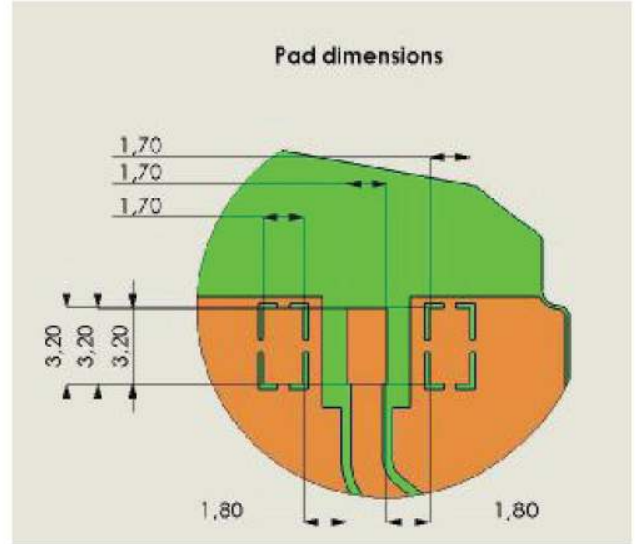
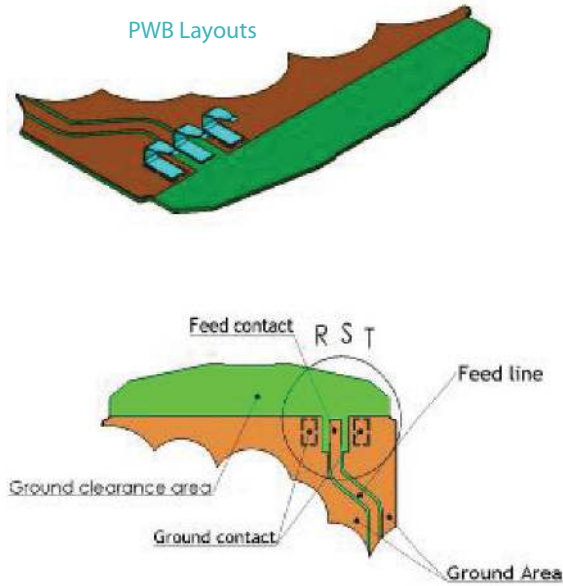

Ground Clearance Area for W9909 C-Clip

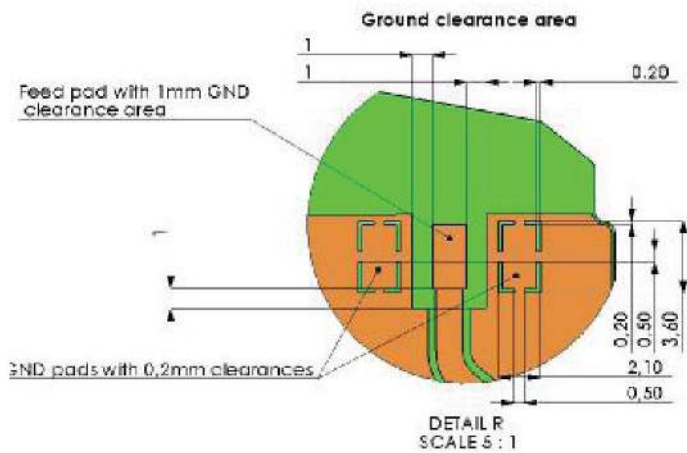

C-clip position on PWB layout

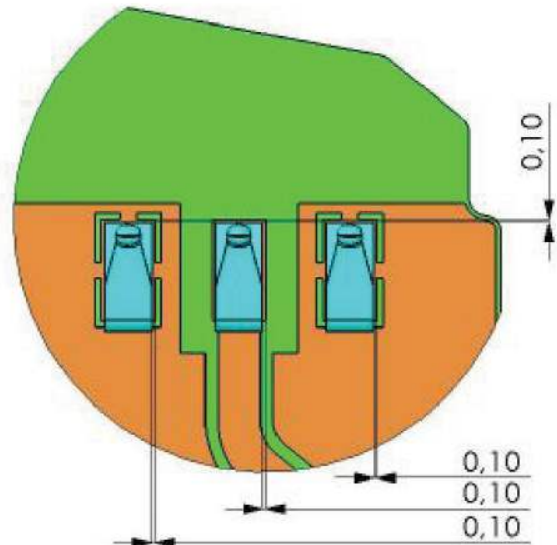

# C-Clip Connector

Pulse Part Number W9909

Reel packing is used for the C-clip.

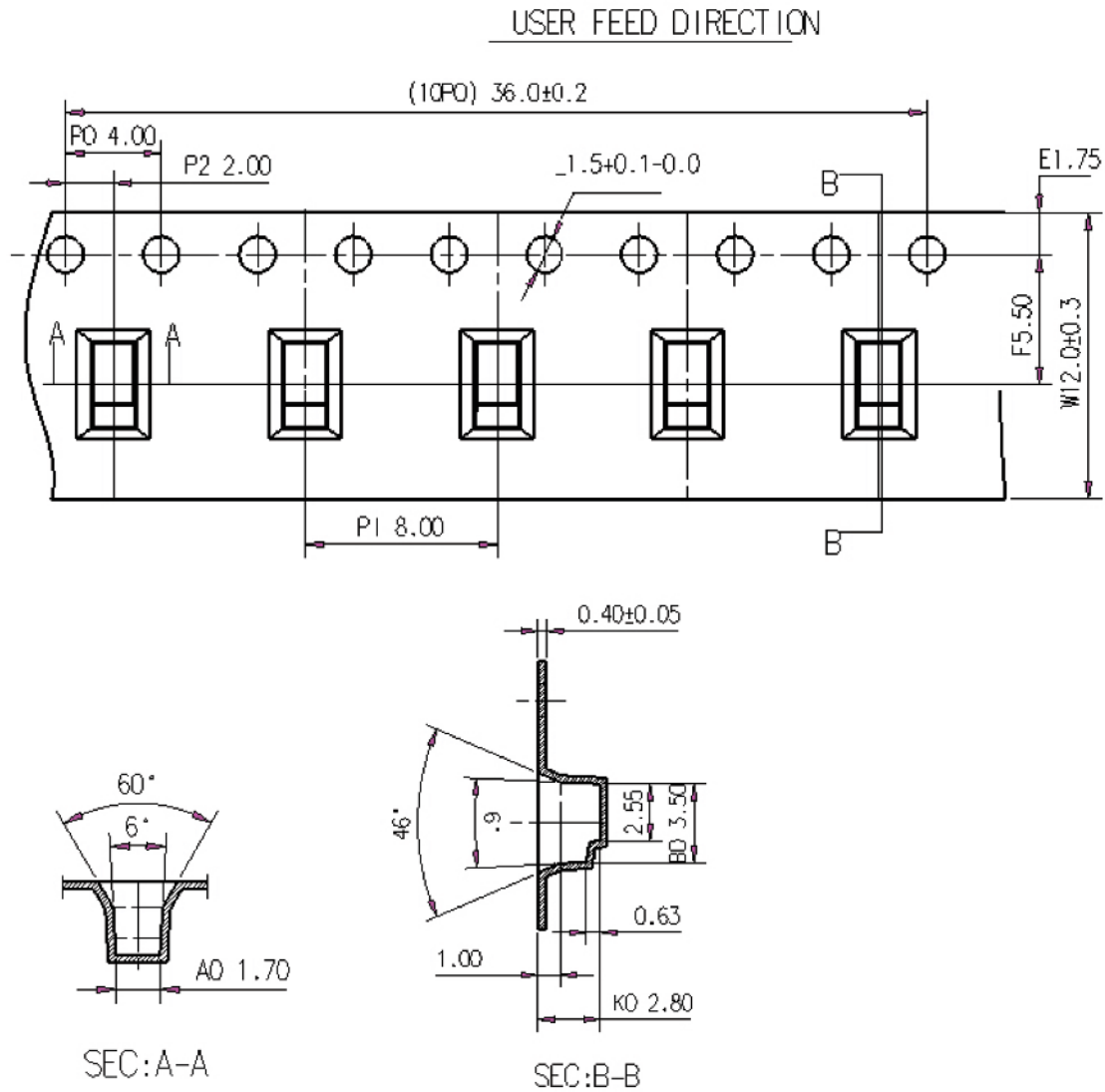

- NOTE:
1. MATERIAL:PS Clear-Thickness: $0.40 \pm 0.05$ mm
  2. Packing Length Per 22" Reel: 60 Meters
  3. Component Load Per 13" Reel: 5000 Pcs
  4. 10 SPROCKET HOLE CUMULATIVE TOLERANCE:  $\pm 0.2$
  5. CARRIER CAMBER IS WITHIN 1mm IN 100mm

Figure 2. Connector packing.

# C-Clip Connector

Pulse Part Number W9909

## W9909 Connector Soldering

### Recommendation for reflow soldering process

Printing stencil thickness 0.15 to 0.25 mm is recommended for the solder paste. The maximum soldering temperature should not exceed 260°C.

The temperature profile recommendations for reflow solder process are presented in Figure 1 and 2. The reflow profile presented in Figure 2 describes maximum reflow temperatures.

Figure 1 - Minimum temperature profile recommendation for reflow soldering process

	Method of heat transfer	Controlled hot air convection
1	Average temperature gradient in preheating	2.5°C/s
2	Soak time	2-3 minutes
3	Max temperature gradient in reflow	3°C/s
4	Time above 217°C	Max 30 sec
5	Peak temperature in reflow	230°C for 10 seconds
6	Temperature gradient in cooling	Max -5°C/s

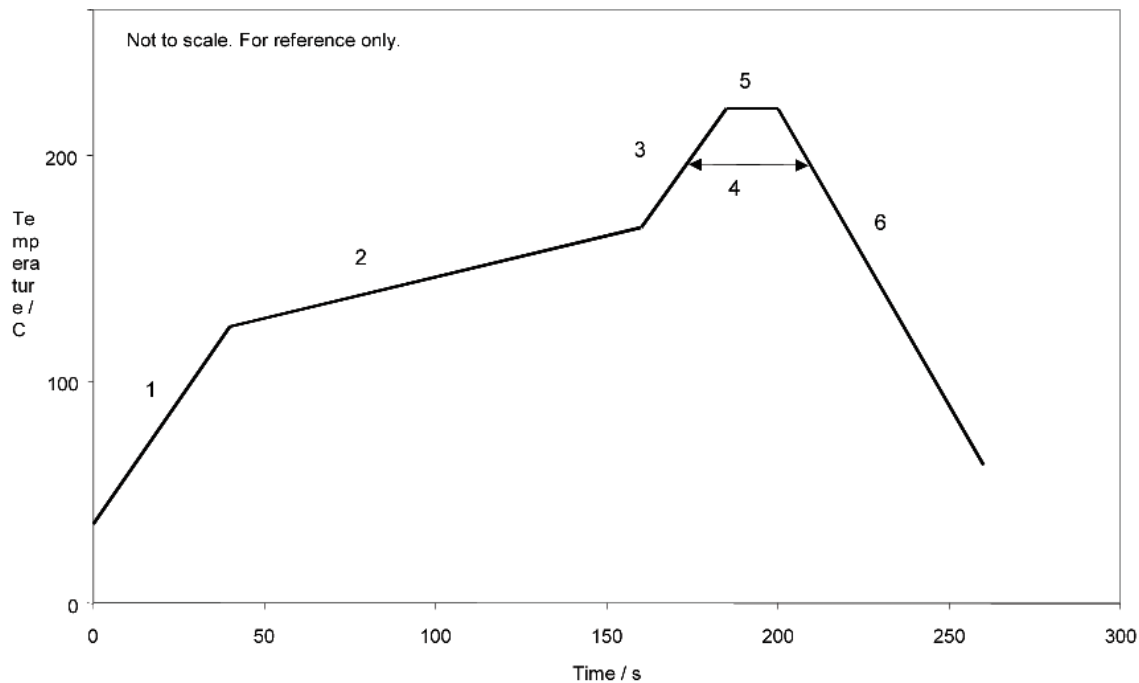

# C-Clip Connector

Pulse Part Number W9909

Figure 2 - Maximum temperature profile recommendation for reflow soldering process

	Method of heat transfer	Controlled hot air convection
1	Average temperature gradient in preheating	2.5°C/s
2	Soak time	2-3 minutes
3	Max temperature gradient in reflow	3°C/s
4	Time above 217°C	Max 60 sec
5	Time above 230°C	Max 50 sec
6	Time above 250°C	Max 10 sec
7	Peak temperature in reflow	260°C for 5 seconds
8	Temperature gradient in cooling	Max -5°C/s

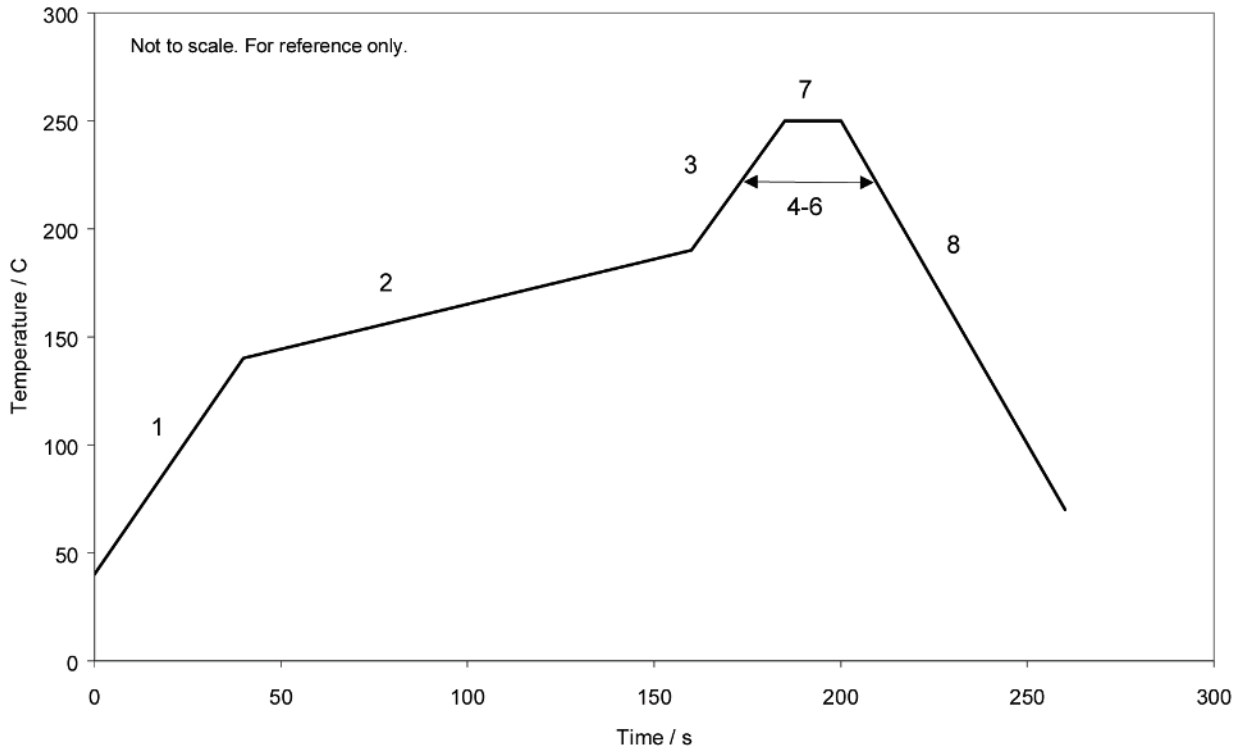

# C-Clip Connector

Pulse Part Number W9909

## SMT notes

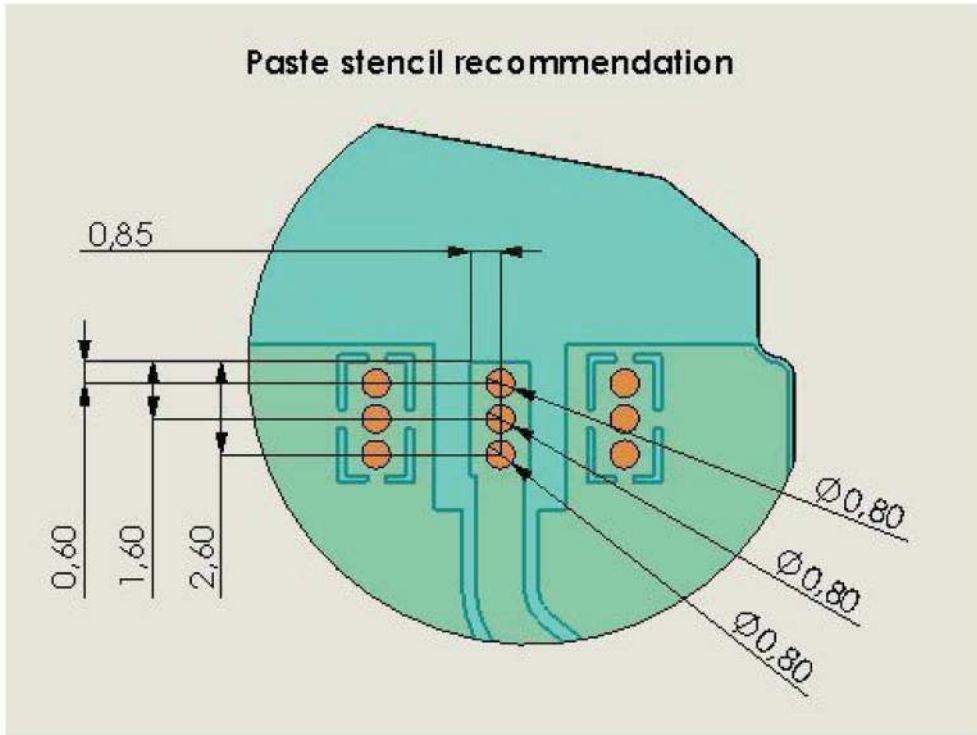

## Pick & Place area

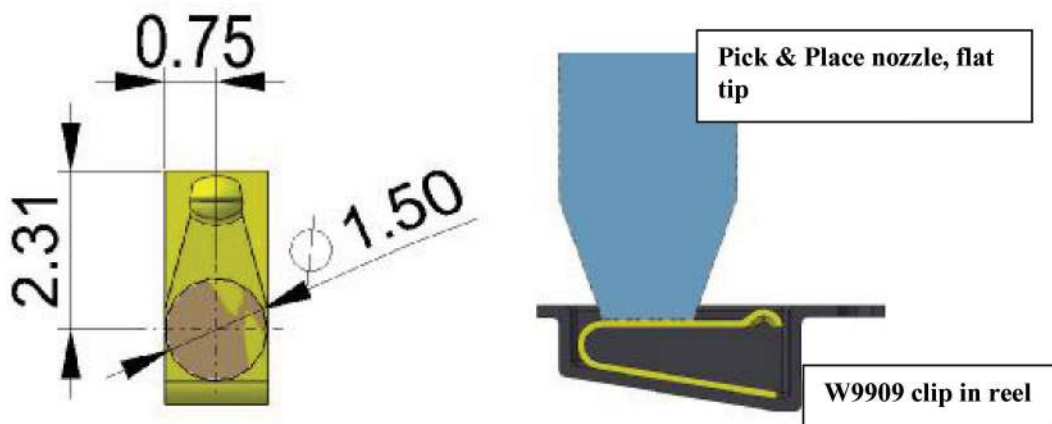

# C-Clip Connector

Pulse Part Number W9909

## SMT setup recommendation

