

LM10 Operational Amplifier and Voltage Reference

1 Features

- Input Offset Voltage: 2 mV (Maximum)
- Input Offset Current: 0.7 nA (Maximum)
- Input Bias Current: 20 nA (Maximum)
- Reference Regulation: 0.1% (Maximum)
- Offset Voltage Drift: 2 $\mu\text{V}/^\circ\text{C}$
- Reference Drift: 0.002%/ $^\circ\text{C}$

2 Applications

- Remote Amplifiers
- Battery-Level Indicators
- Thermocouple Transmitters
- Voltage and Current regulators

3 Description

The LM10 series are monolithic linear ICs consisting of a precision reference, an adjustable reference buffer and an independent, high-quality operational amplifier.

The unit can operate from a total supply voltage as low as 1.1 V or as high as 40 V, drawing only 270 μA . A complementary output stage swings within 15 mV of the supply terminals or will deliver $\pm 20\text{-mA}$ output current with $\pm 0.4\text{-V}$ saturation. Reference output can be as low as 200 mV.

The circuit is recommended for portable equipment and is completely specified for operation from a single power cell. In contrast, high output-drive capability, both voltage and current, along with thermal overload protection, suggest it in demanding general-purpose applications.

The device is capable of operating in a floating mode, independent of fixed supplies. It can function as a remote comparator, signal conditioner, SCR controller or transmitter for analog signals, delivering the processed signal on the same line used to supply power. It is also suited for operation in a wide range of voltage and current regulator applications, from low voltages to several hundred volts, providing greater precision than existing ICs.

This series is available in the three standard temperature ranges, with the commercial part having relaxed limits. In addition, a low-voltage specification (suffix L) is available in the limited temperature ranges at a cost savings.

Device Information⁽¹⁾

PART NUMBER	PACKAGE	BODY SIZE (NOM)
LM10	SOIC (14)	8.992 mm x 7.498 mm
	SDIP (8)	8.255 mm x 8.255 mm
	PDIP (8)	9.81 mm x 6.35 mm

(1) For all available packages, see the orderable addendum at the end of the data sheet.

Operational Amplifier Schematic

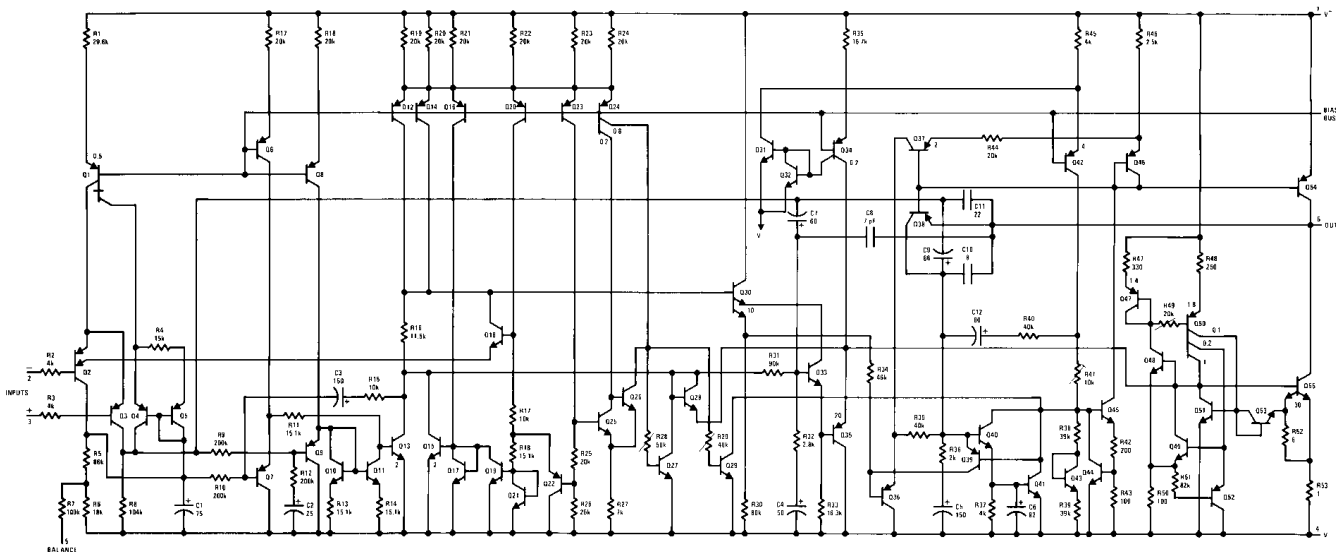

(Pin numbers are for 8-pin packages)



Table of Contents

1 Features 1 2 Applications 1 3 Description 1 4 Revision History 2 5 Pin Configuration and Functions 3 6 Specifications 4 6.1 Absolute Maximum Ratings 4 6.2 Recommended Operating Conditions 4 6.3 Thermal Information 4 6.4 Electrical Characteristics LM10/LM10B 5 6.5 Electrical Characteristics, LM10C 6 6.6 Electrical Characteristics, LM10BL 8 6.7 Electrical Characteristics, LM10CL 9 6.8 Typical Characteristics 11 7 Detailed Description 17 7.1 Overview 17 7.2 Functional Block Diagram 17 7.3 Feature Description 17	7.4 Device Functional Modes 17 8 Application and Implementation 18 8.1 Application Information 18 8.2 Typical Application 18 8.3 System Examples 19 9 Power Supply Recommendations 27 10 Layout 27 10.1 Layout Guidelines 27 10.2 Layout Example 27 11 Device and Documentation Support 28 11.1 Device Support 28 11.2 Documentation Support 28 11.3 Community Resources 28 11.4 Trademarks 29 11.5 Electrostatic Discharge Caution 29 11.6 Glossary 29 12 Mechanical, Packaging, and Orderable Information 29
---	---

4 Revision History

NOTE: Page numbers for previous revisions may differ from page numbers in the current version.

Changes from Revision D (March 2013) to Revision E	Page
<ul style="list-style-type: none"> • Added <i>Pin Configuration and Functions</i> section, <i>ESD Ratings</i> table, <i>Feature Description</i> section, <i>Device Functional Modes</i>, <i>Application and Implementation</i> section, <i>Power Supply Recommendations</i> section, <i>Layout</i> section, <i>Device and Documentation Support</i> section, and <i>Mechanical, Packaging, and Orderable Information</i> section 1 	1

Changes from Revision C (March 2013) to Revision D	Page
<ul style="list-style-type: none"> • Changed layout of National Data Sheet to TI format 26 	26

5 Pin Configuration and Functions

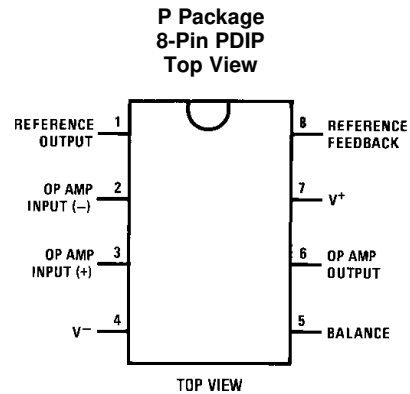
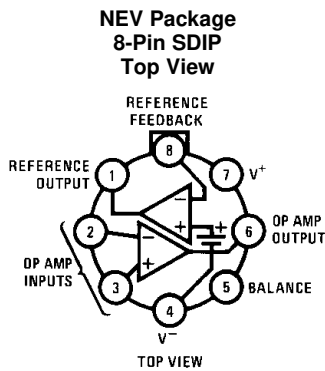

Pin Functions — 8-Pin SDIP or PDIP

PIN		I/O	DESCRIPTION
NAME	NO.		
Balance	5	I	Used for offset nulling
Op Amp Input (+)	3	I	Noninverting input of operational amplifier
Op Amp Input (-)	2	I	Inverting input of operational amplifier
Op Amp Output	6	O	Output terminal of operational amplifier
Reference Feedback	8	I	Feedback terminal of reference
Reference Output	1	O	Output terminal of reference
V+	7	I	Positive supply voltage
V-	4	I	Negative supply voltage

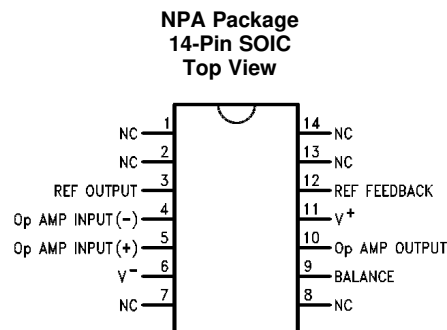

Pin Functions — 14-Pin SOIC

PIN		I/O	DESCRIPTION
NAME	NO.		
Balance	9	I	Used for offset nulling
NC	1, 2, 7, 8, 14, 13	—	No connection
Op Amp Input (-)	4	I	Inverting input of operational amplifier
Op Amp Input (+)	5	I	Noninverting input of operational amplifier
Op Amp Output	10	O	Output terminal of operational amplifier
Reference Feedback	12	I	Feedback terminal of reference
Reference Output	3	O	Output terminal of reference
V+	11	I	Positive supply voltage
V-	6	I	Negative supply voltage

6 Specifications

6.1 Absolute Maximum Ratings

 See ⁽¹⁾⁽²⁾⁽³⁾

		MIN	MAX	UNIT
Total supply voltage	LM10/LM10B/LM10C		45	V
	LM10BL/LM10CL		7	V
Differential input voltage ⁽⁴⁾	LM10/LM10B/LM10C		±40	V
	LM10BL/LM10CL		±7	V
Power dissipation ⁽⁵⁾		Internally limited		
Output short-circuit duration ⁽⁶⁾		Continuous		
Lead temperature	TO	Soldering (10 seconds)		300 °C
	DIP	Soldering (10 seconds)		260 °C
		Vapor phase (60 seconds)		215 °C
		Infrared (15 seconds)		220 °C
Maximum junction temperature	LM10			150 °C
	LM10B			100 °C
	LM10C			85 °C
Storage temperature, T _{stg}		-55	150	°C

- Refer to RETS10X for LM10H military specifications.
- Stresses beyond those listed under *Absolute Maximum Ratings* may cause permanent damage to the device. These are stress ratings only, and functional operation of the device at these or any other conditions beyond those indicated under *Recommended Operating Conditions* is not implied. Exposure to absolute-maximum-rated conditions for extended periods may affect device reliability.
- If Military/Aerospace specified devices are required, please contact the TI Sales Office/Distributors for availability and specifications.
- The Input voltage can exceed the supply voltages provided that the voltage from the input to any other terminal does not exceed the maximum differential input voltage and excess dissipation is accounted for when $V_{IN} < V^-$.
- The maximum, operating-junction temperature is 150°C for the LM10, 100°C for the LM10B(L) and 85°C for the LM10C(L). At elevated temperatures, devices must be derated based on package thermal resistance.
- Internal thermal limiting prevents excessive heating that could result in sudden failure, but the IC can be subjected to accelerated stress with a shorted output and worst-case conditions.

6.2 Recommended Operating Conditions

over operating free-air temperature range (unless otherwise noted)

		MIN	NOM	MAX	UNIT
V _S	Supply input voltage range (V ⁻) – (V ⁺)	1.2		40	V
V _{CM}	Common-mode voltage	(V ⁻)		(V ⁺) – 0.85	V
V _{REF}	Reference voltage		0.2		V
I _{REF}	Reference current	0		1	mA

6.3 Thermal Information

THERMAL METRIC ⁽¹⁾	LM10			UNIT
	NEV (SDIP)	NPA (SOIC)	P (PDIP)	
	8 PINS	14 PINS	8 PINS	
R _{θJA}	Junction-to-ambient thermal resistance			°C/W
R _{θJC(top)}	Junction-to-case (top) thermal resistance			°C/W

- For more information about traditional and new thermal metrics, see the *Semiconductor and IC Package Thermal Metrics* application report, [SPRA953](#).

6.4 Electrical Characteristics LM10/LM10B

 $T_J = 25^\circ\text{C}$ unless otherwise specified⁽¹⁾

PARAMETER	TEST CONDITIONS	MIN	TYP	MAX	UNIT
Input offset voltage	$T_J = 25^\circ\text{C}$		0.3	2	mV
	$T_{\text{MIN}} \leq T_J \leq T_{\text{MAX}}$ (see ⁽¹⁾)			3	mV
Input offset current ⁽²⁾	$T_J = 25^\circ\text{C}$		0.25	0.7	nA
	$T_{\text{MIN}} \leq T_J \leq T_{\text{MAX}}$ (see ⁽¹⁾)			1.5	nA
Input bias current	$T_J = 25^\circ\text{C}$		10	20	nA
	$T_{\text{MIN}} \leq T_J \leq T_{\text{MAX}}$ (see ⁽¹⁾)			30	nA
Input resistance	$T_J = 25^\circ\text{C}$	250	500		k Ω
	$T_{\text{MIN}} \leq T_J \leq T_{\text{MAX}}$ (see ⁽¹⁾)	150			k Ω
Large signal voltage gain	$V_S = \pm 20\text{ V}$, $I_{\text{OUT}} = 0$	120	400		V/mV
	$V_{\text{OUT}} = \pm 19.95\text{ V}$, $T_{\text{MIN}} \leq T_J \leq T_{\text{MAX}}$ (see ⁽¹⁾)	80			V/mV
	$V_S = \pm 20\text{ V}$, $V_{\text{OUT}} = \pm 19.4\text{ V}$	50	130		V/mV
	$I_{\text{OUT}} = \pm 20\text{ mA}$, $T_{\text{MIN}} \leq T_J \leq T_{\text{MAX}}$ (see ⁽¹⁾)	20			V/mV
	$I_{\text{OUT}} = \pm 15\text{ mA}$, $T_{\text{MIN}} \leq T_J \leq T_{\text{MAX}}$ (see ⁽¹⁾)	20			V/mV
	$V_S = \pm 0.6\text{ V}$, $I_{\text{OUT}} = \pm 2\text{ mA}$	1.5	3		V/mV
	$V_S = \pm 0.65\text{ V}$, $I_{\text{OUT}} = \pm 2\text{ mA}$, $T_{\text{MIN}} \leq T_J \leq T_{\text{MAX}}$ (see ⁽¹⁾)	1.5	3		V/mV
	$V_{\text{OUT}} = \pm 0.4\text{ V}$, $T_{\text{MIN}} \leq T_J \leq T_{\text{MAX}}$ (see ⁽¹⁾)	0.5			V/mV
Shunt gain ⁽³⁾	$V_{\text{OUT}} = \pm 0.3\text{ V}$, $V_{\text{CM}} = -0.4\text{ V}$, $T_{\text{MIN}} \leq T_J \leq T_{\text{MAX}}$ (see ⁽¹⁾)	0.5			V/mV
	$1.2\text{ V} \leq V_{\text{OUT}} \leq 40\text{ V}$, $R_L = 1.1\text{ k}\Omega$	14	33		V/mV
	$1.3\text{ V} \leq V_{\text{OUT}} \leq 40\text{ V}$, $R_L = 1.1\text{ k}\Omega$, $T_{\text{MIN}} \leq T_J \leq T_{\text{MAX}}$ (see ⁽¹⁾)	14	33		V/mV
	$0.1\text{ mA} \leq I_{\text{OUT}} \leq 5\text{ mA}$, $T_{\text{MIN}} \leq T_J \leq T_{\text{MAX}}$ (see ⁽¹⁾)	6			V/mV
	$1.5\text{ V} \leq V^+ \leq 40\text{ V}$, $R_L = 250\ \Omega$	8	25		V/mV
Common-mode rejection	$0.1\text{ mA} \leq I_{\text{OUT}} \leq 20\text{ mA}$, $T_{\text{MIN}} \leq T_J \leq T_{\text{MAX}}$ (see ⁽¹⁾)	4			V/mV
	$-20\text{ V} \leq V_{\text{CM}} \leq 19.15\text{ V}$	93	102		dB
	$-20\text{ V} \leq V_{\text{CM}} \leq 19\text{ V}$, $T_{\text{MIN}} \leq T_J \leq T_{\text{MAX}}$ (see ⁽¹⁾)	93	102		dB
Supply-voltage rejection	$V_S = \pm 20\text{ V}$, $T_{\text{MIN}} \leq T_J \leq T_{\text{MAX}}$ (see ⁽¹⁾)	87			dB
	$-0.2\text{ V} \geq V^- \geq -39\text{ V}$	90	96		dB
	$V^+ = 1\text{ V}$, $T_{\text{MIN}} \leq T_J \leq T_{\text{MAX}}$ (see ⁽¹⁾)	84			dB
	$V^+ = 1.1\text{ V}$, $T_{\text{MIN}} \leq T_J \leq T_{\text{MAX}}$ (see ⁽¹⁾)	84			dB
	$1\text{ V} \leq V^+ \leq 39.8\text{ V}$	96	106		dB
Offset voltage drift	$1.1\text{ V} \leq V^+ \leq 39.8\text{ V}$, $T_{\text{MIN}} \leq T_J \leq T_{\text{MAX}}$ (see ⁽¹⁾)	96	106		dB
	$V^- = -0.2\text{ V}$, $T_{\text{MIN}} \leq T_J \leq T_{\text{MAX}}$ (see ⁽¹⁾)	90			dB
Offset current drift			2		$\mu\text{V}/^\circ\text{C}$
Bias current drift			2		$\text{pA}/^\circ\text{C}$
Line regulation	$T_C < 100^\circ\text{C}$		60		$\text{pA}/^\circ\text{C}$
	$1.2\text{ V} \leq V_S \leq 40\text{ V}$		0.001	0.003	%/V
	$1.3\text{ V} \leq V_S \leq 40\text{ V}$, $T_{\text{MIN}} \leq T_J \leq T_{\text{MAX}}$ (see ⁽¹⁾)		0.001	0.003	%/V
Load regulation	$0 \leq I_{\text{REF}} \leq 1\text{ mA}$, $V_{\text{REF}} = 200\text{ mV}$, $T_{\text{MIN}} \leq T_J \leq T_{\text{MAX}}$ (see ⁽¹⁾)			0.006	%/V
	$0 \leq I_{\text{REF}} \leq 1\text{ mA}$		0.01%	0.1%	
	$V^+ - V_{\text{REF}} \geq 1\text{ V}$, $T_{\text{MIN}} \leq T_J \leq T_{\text{MAX}}$ (see ⁽¹⁾)			0.15%	
	$V^+ - V_{\text{REF}} \geq 1.1\text{ V}$, $T_{\text{MIN}} \leq T_J \leq T_{\text{MAX}}$ (see ⁽¹⁾)			0.15%	

(1) These specifications apply for $V^- \leq V_{\text{CM}} \leq V^+ - 0.85\text{ V}$, 1 V ($T_{\text{MIN}} \leq T_J \leq T_{\text{MAX}}$), 1.2 V , 1.3 V ($T_{\text{MIN}} \leq T_J \leq T_{\text{MAX}}$) $< V_S \leq V_{\text{MAX}}$, $V_{\text{REF}} = 0.2\text{ V}$ and $0 \leq I_{\text{REF}} \leq 1\text{ mA}$, unless otherwise specified: $V_{\text{MAX}} = 40\text{ V}$ for the standard part and 6.5 V for the low voltage part. The full-temperature-range operation is -55°C to 125°C for the LM10, -25°C to 85°C for the LM10B(L) and 0°C to 70°C for the LM10C(L). The specifications do not include the effects of thermal gradients ($\tau_1 \approx 20\text{ ms}$), die heating ($\tau_2 \approx 0.2\text{ s}$) or package heating. Gradient effects are small and tend to offset the electrical error (see curves).

(2) For $T_J > 90^\circ\text{C}$, I_{OS} may exceed 1.5 nA for $V_{\text{CM}} = V^-$. With $T_J = 125^\circ\text{C}$ and $V^- \leq V_{\text{CM}} \leq V^- + 0.1\text{ V}$, $I_{\text{OS}} \leq 5\text{ nA}$.

(3) This defines operation in floating applications such as the bootstrapped regulator or two-wire transmitter. Output is connected to the V^+ terminal of the IC and input common mode is referred to V^- (see [System Examples](#)). Effect of larger output-voltage swings with higher load resistance can be accounted for by adding the positive-supply rejection error.

Electrical Characteristics LM10/LM10B (continued)
 $T_J = 25^\circ\text{C}$ unless otherwise specified⁽¹⁾

PARAMETER	TEST CONDITIONS	MIN	TYP	MAX	UNIT
Amplifier gain	$0.2\text{ V} \leq V_{\text{REF}} \leq 35\text{ V}$	$T_J = 25^\circ\text{C}$	50	75	V/mV
		$T_{\text{MIN}} \leq T_J \leq T_{\text{MAX}}$ (see ⁽¹⁾)	23		V/mV
Feedback sense voltage	$T_J = 25^\circ\text{C}$	195	200	205	mV
	$T_{\text{MIN}} \leq T_J \leq T_{\text{MAX}}$ (see ⁽¹⁾)	194		206	mV
Feedback current	$T_J = 25^\circ\text{C}$		20	50	nA
	$T_{\text{MIN}} \leq T_J \leq T_{\text{MAX}}$ (see ⁽¹⁾)			65	nA
Reference drift			0.002		%/°C
Supply current	$T_J = 25^\circ\text{C}$		270	400	μA
	$T_{\text{MIN}} \leq T_J \leq T_{\text{MAX}}$ (see ⁽¹⁾)			500	μA
Supply current change	$1.2\text{ V} \leq V_S \leq 40\text{ V}$	$T_J = 25^\circ\text{C}$	15		μA
		$T_{\text{MIN}} \leq T_J \leq T_{\text{MAX}}$ (see ⁽¹⁾)			75
	$1.3\text{ V} \leq V_S \leq 40\text{ V}$	$T_J = 25^\circ\text{C}$	15		μA
		$T_{\text{MIN}} \leq T_J \leq T_{\text{MAX}}$ (see ⁽¹⁾)			75

6.5 Electrical Characteristics, LM10C
 $T_J = 25^\circ\text{C}$ unless otherwise specified⁽¹⁾

PARAMETER	TEST CONDITIONS	MIN	TYP	MAX	UNIT
Input offset voltage	$T_J = 25^\circ\text{C}$		0.5	4	mV
	$T_{\text{MIN}} \leq T_J \leq T_{\text{MAX}}$ (see ⁽¹⁾)			5	mV
Input offset current ⁽²⁾	$T_J = 25^\circ\text{C}$		0.4	2	nA
	$T_{\text{MIN}} \leq T_J \leq T_{\text{MAX}}$ (see ⁽¹⁾)			3	nA
Input bias current	$T_J = 25^\circ\text{C}$		12	30	nA
	$T_{\text{MIN}} \leq T_J \leq T_{\text{MAX}}$ (see ⁽¹⁾)			40	nA
Input resistance	$T_J = 25^\circ\text{C}$	150	400		kΩ
	$T_{\text{MIN}} \leq T_J \leq T_{\text{MAX}}$ (see ⁽¹⁾)	115			kΩ
Large signal voltage gain	$V_S = \pm 20\text{ V}$, $I_{\text{OUT}} = 0$	80	400		V/mV
	$V_{\text{OUT}} = \pm 19.95\text{ V}$, $T_{\text{MIN}} \leq T_J \leq T_{\text{MAX}}$ (see ⁽¹⁾)	50			V/mV
	$V_S = \pm 20\text{ V}$, $V_{\text{OUT}} = \pm 19.4\text{ V}$	25	130		V/mV
	$I_{\text{OUT}} = \pm 20\text{ mA}$, $T_{\text{MIN}} \leq T_J \leq T_{\text{MAX}}$ (see ⁽¹⁾)	15			V/mV
	$I_{\text{OUT}} = \pm 15\text{ mA}$, $T_{\text{MIN}} \leq T_J \leq T_{\text{MAX}}$ (see ⁽¹⁾)	15			V/mV
	$V_S = \pm 0.6\text{ V}$, $I_{\text{OUT}} = \pm 2\text{ mA}$	1	3		V/mV
	$V_S = 0.65\text{ V}$, $I_{\text{OUT}} = \pm 2\text{ mA}$, $T_{\text{MIN}} \leq T_J \leq T_{\text{MAX}}$ (see ⁽¹⁾)	1	3		V/mV
	$V_{\text{OUT}} = \pm 0.4\text{ V}$, $T_{\text{MIN}} \leq T_J \leq T_{\text{MAX}}$ (see ⁽¹⁾)	0.75			V/mV
Shunt gain ⁽³⁾	$V_{\text{OUT}} = \pm 0.3\text{ V}$, $V_{\text{CM}} = -0.4\text{ V}$, $T_{\text{MIN}} \leq T_J \leq T_{\text{MAX}}$ (see ⁽¹⁾)	0.75			V/mV
	$1.2\text{ V} \leq V_{\text{OUT}} \leq 40\text{ V}$, $R_L = 1.1\text{ k}\Omega$	10	33		V/mV
	$1.3\text{ V} \leq V_{\text{OUT}} \leq 40\text{ V}$, $R_L = 1.1\text{ k}\Omega$, $T_{\text{MIN}} \leq T_J \leq T_{\text{MAX}}$ (see ⁽¹⁾)	10	33		V/mV
	$0.1\text{ mA} \leq I_{\text{OUT}} \leq 5\text{ mA}$, $T_{\text{MIN}} \leq T_J \leq T_{\text{MAX}}$ (see ⁽¹⁾)	6			V/mV
	$1.5\text{ V} \leq V^+ \leq 40\text{ V}$, $R_L = 250\text{ }\Omega$	6	25		V/mV
	$0.1\text{ mA} \leq I_{\text{OUT}} \leq 20\text{ mA}$, $T_{\text{MIN}} \leq T_J \leq T_{\text{MAX}}$ (see ⁽¹⁾)	4			V/mV

(1) These specifications apply for $V^- \leq V_{\text{CM}} \leq V^+ - 0.85\text{ V}$, 1 V ($T_{\text{MIN}} \leq T_J \leq T_{\text{MAX}}$), 1.2 V , 1.3 V ($T_{\text{MIN}} \leq T_J \leq T_{\text{MAX}}$) $< V_S \leq V_{\text{MAX}}$, $V_{\text{REF}} = 0.2\text{ V}$ and $0 \leq I_{\text{REF}} \leq 1\text{ mA}$, unless otherwise specified: $V_{\text{MAX}} = 40\text{ V}$ for the standard part and 6.5 V for the low voltage part. The full-temperature-range operation is -55°C to 125°C for the LM10, -25°C to 85°C for the LM10B(L) and 0°C to 70°C for the LM10C(L). The specifications do not include the effects of thermal gradients ($\tau_1 \approx 20\text{ ms}$), die heating ($\tau_2 \approx 0.2\text{ s}$) or package heating. Gradient effects are small and tend to offset the electrical error (see curves).

(2) For $T_J > 90^\circ\text{C}$, I_{OS} may exceed 1.5 nA for $V_{\text{CM}} = V^-$. With $T_J = 125^\circ\text{C}$ and $V^- \leq V_{\text{CM}} \leq V^- + 0.1\text{ V}$, $I_{\text{OS}} \leq 5\text{ nA}$.

(3) This defines operation in floating applications such as the bootstrapped regulator or two-wire transmitter. Output is connected to the V^+ terminal of the IC and input common mode is referred to V^- (see [System Examples](#)). Effect of larger output-voltage swings with higher load resistance can be accounted for by adding the positive-supply rejection error.

Electrical Characteristics, LM10C (continued)
 $T_J = 25^\circ\text{C}$ unless otherwise specified⁽¹⁾

PARAMETER	TEST CONDITIONS	MIN	TYP	MAX	UNIT
Common-mode rejection	$-20\text{ V} \leq V_{CM} \leq 19.15\text{ V}$	90	102		dB
	$-20\text{ V} \leq V_{CM} \leq 19\text{ V}$	90	102		dB
	$V_S = \pm 20\text{ V}$, $T_{MIN} \leq T_J \leq T_{MAX}$ (see ⁽¹⁾)	87			dB
Supply-voltage rejection	$-0.2\text{ V} \geq V^- \geq -39\text{ V}$	87	96		dB
	$V^+ = 1\text{ V}$, $T_{MIN} \leq T_J \leq T_{MAX}$ (see ⁽¹⁾)	84			dB
	$V^+ = 1.1\text{ V}$, $T_{MIN} \leq T_J \leq T_{MAX}$ (see ⁽¹⁾)	84			dB
	$1\text{ V} \leq V^+ \leq 39.8\text{ V}$	93	106		dB
	$1.1\text{ V} \leq V^+ \leq 39.8\text{ V}$, $T_{MIN} \leq T_J \leq T_{MAX}$ (see ⁽¹⁾)	93	106		dB
	$V^- = -0.2\text{ V}$, $T_{MIN} \leq T_J \leq T_{MAX}$ (see ⁽¹⁾)	90			dB
Offset voltage drift			5		$\mu\text{V}/^\circ\text{C}$
Offset current drift			5		$\text{pA}/^\circ\text{C}$
Bias current drift	$T_C < 100^\circ\text{C}$		90		$\text{pA}/^\circ\text{C}$
Line regulation	$1.2\text{ V} \leq V_S \leq 40\text{ V}$		0.001	0.008	%/V
	$1.3\text{ V} \leq V_S \leq 40\text{ V}$, $T_{MIN} \leq T_J \leq T_{MAX}$ (see ⁽¹⁾)		0.001	0.008	%/V
	$0 \leq I_{REF} \leq 1\text{ mA}$, $V_{REF} = 200\text{ mV}$, $T_{MIN} \leq T_J \leq T_{MAX}$ (see ⁽¹⁾)			0.01	%/V
Load regulation	$0 \leq I_{REF} \leq 1\text{ mA}$		0.01%	0.15%	
	$V^+ - V_{REF} \geq 1\text{ V}$, $T_{MIN} \leq T_J \leq T_{MAX}$ (see ⁽¹⁾)			0.2%	
	$V^+ - V_{REF} \geq 1.1\text{ V}$, $T_{MIN} \leq T_J \leq T_{MAX}$ (see ⁽¹⁾)			0.2%	
Amplifier gain	$0.2\text{ V} \leq V_{REF} \leq 35\text{ V}$	$T_J = 25^\circ\text{C}$	25	70	V/mV
		$T_{MIN} \leq T_J \leq T_{MAX}$ (see ⁽¹⁾)	15		V/mV
Feedback sense voltage	$T_J = 25^\circ\text{C}$	190	200	210	mV
	$T_{MIN} \leq T_J \leq T_{MAX}$ (see ⁽¹⁾)	189		211	mV
Feedback current	$T_J = 25^\circ\text{C}$		22	75	nA
	$T_{MIN} \leq T_J \leq T_{MAX}$ (see ⁽¹⁾)			90	nA
Reference drift			0.003		%/°C
Supply current	$T_J = 25^\circ\text{C}$		300	500	μA
	$T_{MIN} \leq T_J \leq T_{MAX}$ (see ⁽¹⁾)			570	μA
Supply current change	$1.2\text{ V} \leq V_S \leq 40\text{ V}$	$T_J = 25^\circ\text{C}$	15		μA
		$T_{MIN} \leq T_J \leq T_{MAX}$ (see ⁽¹⁾)			75
	$1.3\text{ V} \leq V_S \leq 40\text{ V}$	$T_J = 25^\circ\text{C}$	15		μA
		$T_{MIN} \leq T_J \leq T_{MAX}$ (see ⁽¹⁾)			75

6.6 Electrical Characteristics, LM10BL

 $T_J = 25^\circ\text{C}$ unless otherwise specified. ⁽¹⁾

PARAMETER	TEST CONDITIONS	MIN	TYP	MAX	UNIT
Input offset voltage	$T_J = 25^\circ\text{C}$		0.3	2	mV
	$T_{\text{MIN}} \leq T_J \leq T_{\text{MAX}}$ (see ⁽¹⁾)			3	mV
Input offset current ⁽²⁾	$T_J = 25^\circ\text{C}$		0.1	0.7	nA
	$T_{\text{MIN}} \leq T_J \leq T_{\text{MAX}}$ (see ⁽¹⁾)			1.5	nA
Input bias current	$T_J = 25^\circ\text{C}$		10	20	nA
	$T_{\text{MIN}} \leq T_J \leq T_{\text{MAX}}$ (see ⁽¹⁾)			30	nA
Input resistance	$T_J = 25^\circ\text{C}$	250	500		k Ω
	$T_{\text{MIN}} \leq T_J \leq T_{\text{MAX}}$ (see ⁽¹⁾)	150			k Ω
Large signal voltage gain	$V_S = \pm 3.25\text{ V}$, $I_{\text{OUT}} = 0$	60	300		V/mV
	$V_{\text{OUT}} = \pm 3.2\text{ V}$, $T_{\text{MIN}} \leq T_J \leq T_{\text{MAX}}$ (see ⁽¹⁾)	40			V/mV
	$V_S = \pm 3.25\text{ V}$, $I_{\text{OUT}} = 10\text{ mA}$	10	25		V/mV
	$V_{\text{OUT}} = \pm 2.75\text{ V}$, $T_{\text{MIN}} \leq T_J \leq T_{\text{MAX}}$ (see ⁽¹⁾)	4			V/mV
	$V_S = \pm 0.6\text{ V}$, $I_{\text{OUT}} = \pm 2\text{ mA}$	1.5	3		V/mV
	$V_S = 0.65\text{ V}$, $I_{\text{OUT}} = \pm 2\text{ mA}$, $T_{\text{MIN}} \leq T_J \leq T_{\text{MAX}}$ (see ⁽¹⁾)	1.5	3		V/mV
	$V_{\text{OUT}} = \pm 0.4\text{ V}$, $V_{\text{CM}} = -0.4\text{ V}$, $T_{\text{MIN}} \leq T_J \leq T_{\text{MAX}}$ (see ⁽¹⁾)	0.5			V/mV
	$V_{\text{OUT}} = \pm 0.3\text{ V}$, $V_{\text{CM}} = -0.4\text{ V}$, $T_{\text{MIN}} \leq T_J \leq T_{\text{MAX}}$ (see ⁽¹⁾)	0.5			V/mV
Shunt gain ⁽³⁾	$1.5\text{ V} \leq V^+ \leq 6.5\text{ V}$, $R_L = 500\ \Omega$	8	30		V/mV
	$0.1\text{ mA} \leq I_{\text{OUT}} \leq 10\text{ mA}$, $T_{\text{MIN}} \leq T_J \leq T_{\text{MAX}}$ (see ⁽¹⁾)	4			V/mV
Common-mode rejection	$-3.25\text{ V} \leq V_{\text{CM}} \leq 2.4\text{ V}$	89	102		dB
	$-3.25\text{ V} \leq V_{\text{CM}} \leq 2.25\text{ V}$, $T_{\text{MIN}} \leq T_J \leq T_{\text{MAX}}$ (see ⁽¹⁾)				
	$V_S = \pm 3.25\text{ V}$, $T_{\text{MIN}} \leq T_J \leq T_{\text{MAX}}$ (see ⁽¹⁾)	83			
Supply-voltage rejection	$-0.2\text{ V} \geq V^- \geq -5.4\text{ V}$	86	96		dB
	$V^+ = 1\text{ V}$, $T_{\text{MIN}} \leq T_J \leq T_{\text{MAX}}$ (see ⁽¹⁾)	80			dB
	$V^+ = 1.2\text{ V}$, $T_{\text{MIN}} \leq T_J \leq T_{\text{MAX}}$ (see ⁽¹⁾)	80			dB
	$1\text{ V} \leq V^+ \leq 6.3\text{ V}$	94	106		dB
	$1.1\text{ V} \leq V^+ \leq 6.3\text{ V}$, $T_{\text{MIN}} \leq T_J \leq T_{\text{MAX}}$ (see ⁽¹⁾)	94	106		dB
	$V^- = 0.2\text{ V}$, $T_{\text{MIN}} \leq T_J \leq T_{\text{MAX}}$ (see ⁽¹⁾)	88			dB
Offset voltage drift			2		$\mu\text{V}/^\circ\text{C}$
Offset current drift			2		$\text{pA}/^\circ\text{C}$
Bias current drift			60		$\text{pA}/^\circ\text{C}$
Line regulation	$1.2\text{ V} \leq V_S \leq 6.5\text{ V}$		0.001	0.01	%/V
	$1.3\text{ V} \leq V_S \leq 6.5\text{ V}$, $T_{\text{MIN}} \leq T_J \leq T_{\text{MAX}}$ (see ⁽¹⁾)		0.001	0.01	%/V
	$0 \leq I_{\text{REF}} \leq 0.5\text{ mA}$, $V_{\text{REF}} = 200\text{ mV}$, $T_{\text{MIN}} \leq T_J \leq T_{\text{MAX}}$ (see ⁽¹⁾)			0.02	%/V
Load regulation	$0 \leq I_{\text{REF}} \leq 0.5\text{ mA}$		0.01%	0.1%	
	$V^+ - V_{\text{REF}} \geq 1\text{ V}$, $T_{\text{MIN}} \leq T_J \leq T_{\text{MAX}}$ (see ⁽¹⁾)			0.15%	
	$V^+ - V_{\text{REF}} \geq 1.1\text{ V}$, $T_{\text{MIN}} \leq T_J \leq T_{\text{MAX}}$ (see ⁽¹⁾)			0.15%	
Amplifier gain	$0.2\text{ V} \leq V_{\text{REF}} \leq 5.5\text{ V}$	$T_J = 25^\circ\text{C}$	30	70	V/mV
		$T_{\text{MIN}} \leq T_J \leq T_{\text{MAX}}$ (see ⁽¹⁾)	20		V/mV
Feedback sense voltage	$T_J = 25^\circ\text{C}$	195	200	205	mV
	$T_{\text{MIN}} \leq T_J \leq T_{\text{MAX}}$ (see ⁽¹⁾)	194		206	mV

(1) These specifications apply for $V^- \leq V_{\text{CM}} \leq V^+ - 0.85\text{ V}$, 1 V ($T_{\text{MIN}} \leq T_J \leq T_{\text{MAX}}$), 1.2 V , 1.3 V ($T_{\text{MIN}} \leq T_J \leq T_{\text{MAX}}$) $< V_S \leq V_{\text{MAX}}$, $V_{\text{REF}} = 0.2\text{ V}$ and $0 \leq I_{\text{REF}} \leq 1\text{ mA}$, unless otherwise specified: $V_{\text{MAX}} = 40\text{ V}$ for the standard part and 6.5 V for the low voltage part. The full-temperature-range operation is -55°C to 125°C for the LM10, -25°C to 85°C for the LM10B(L) and 0°C to 70°C for the LM10C(L). The specifications do not include the effects of thermal gradients ($\tau_1 \approx 20\text{ ms}$), die heating ($\tau_2 \approx 0.2\text{ s}$) or package heating. Gradient effects are small and tend to offset the electrical error (see curves).

(2) For $T_J > 90^\circ\text{C}$, I_{OS} may exceed 1.5 nA for $V_{\text{CM}} = V^-$. With $T_J = 125^\circ\text{C}$ and $V^- \leq V_{\text{CM}} \leq V^- + 0.1\text{ V}$, $I_{\text{OS}} \leq 5\text{ nA}$.

(3) This defines operation in floating applications such as the bootstrapped regulator or two-wire transmitter. Output is connected to the V^+ terminal of the IC and input common mode is referred to V^- (see [System Examples](#)). Effect of larger output-voltage swings with higher load resistance can be accounted for by adding the positive-supply rejection error.

Electrical Characteristics, LM10BL (continued)

 $T_J = 25^\circ\text{C}$ unless otherwise specified.⁽¹⁾

PARAMETER	TEST CONDITIONS	MIN	TYP	MAX	UNIT
Feedback current	$T_J = 25^\circ\text{C}$		20	50	nA
	$T_{\text{MIN}} \leq T_J \leq T_{\text{MAX}}$ (see ⁽¹⁾)			65	nA
Reference drift			0.002		%/°C
Supply current	$T_J = 25^\circ\text{C}$		260	400	μA
	$T_{\text{MIN}} \leq T_J \leq T_{\text{MAX}}$ (see ⁽¹⁾)			500	μA

6.7 Electrical Characteristics, LM10CL

 $T_J = 25^\circ\text{C}$ unless otherwise specified.⁽¹⁾

PARAMETER	TEST CONDITIONS	MIN	TYP	MAX	UNIT
Input offset voltage	$T_J = 25^\circ\text{C}$		0.5	4	mV
	$T_{\text{MIN}} \leq T_J \leq T_{\text{MAX}}$ (see ⁽¹⁾)			5	mV
Input offset current ⁽²⁾	$T_J = 25^\circ\text{C}$		0.2	2	nA
	$T_{\text{MIN}} \leq T_J \leq T_{\text{MAX}}$ (see ⁽¹⁾)			3	nA
Input bias current	$T_J = 25^\circ\text{C}$		12	30	nA
	$T_{\text{MIN}} \leq T_J \leq T_{\text{MAX}}$ (see ⁽¹⁾)			40	nA
Input resistance	$T_J = 25^\circ\text{C}$	150	400		kΩ
	$T_{\text{MIN}} \leq T_J \leq T_{\text{MAX}}$ (see ⁽¹⁾)	115			kΩ
Large signal voltage gain	$V_S = \pm 3.25\text{ V}$, $I_{\text{OUT}} = 0$	40	300		V/mV
	$V_{\text{OUT}} = \pm 3.2\text{ V}$, $T_{\text{MIN}} \leq T_J \leq T_{\text{MAX}}$ (see ⁽¹⁾)	25			V/mV
	$V_S = \pm 3.25\text{ V}$, $I_{\text{OUT}} = 10\text{ mA}$	5	25		V/mV
	$V_{\text{OUT}} = \pm 2.75\text{ V}$, $T_{\text{MIN}} \leq T_J \leq T_{\text{MAX}}$ (see ⁽¹⁾)	3			V/mV
	$V_S = \pm 0.6\text{ V}$, $I_{\text{OUT}} = \pm 2\text{ mA}$	1	3		V/mV
	$V_S = 0.65\text{ V}$, $I_{\text{OUT}} = \pm 2\text{ mA}$, $T_{\text{MIN}} \leq T_J \leq T_{\text{MAX}}$ (see ⁽¹⁾)	1	3		V/mV
	$V_{\text{OUT}} = \pm 0.4\text{ V}$, $V_{\text{CM}} = -0.4\text{ V}$, $T_{\text{MIN}} \leq T_J \leq T_{\text{MAX}}$ (see ⁽¹⁾)	0.75			V/mV
Shunt gain ⁽³⁾	$1.5\text{ V} \leq V^+ \leq 6.5\text{ V}$, $R_L = 500\ \Omega$	6	30		V/mV
	$0.1\text{ mA} \leq I_{\text{OUT}} \leq 10\text{ mA}$, $T_{\text{MIN}} \leq T_J \leq T_{\text{MAX}}$ (see ⁽¹⁾)	4			V/mV
Common-mode rejection	$-3.25\text{ V} \leq V_{\text{CM}} \leq 2.4\text{ V}$	80	102		dB
	$-3.25\text{ V} \leq V_{\text{CM}} \leq 2.25\text{ V}$, $T_{\text{MIN}} \leq T_J \leq T_{\text{MAX}}$ (see ⁽¹⁾)	80	102		dB
	$V_S = \pm 3.25\text{ V}$, $T_{\text{MIN}} \leq T_J \leq T_{\text{MAX}}$ (see ⁽¹⁾)	74			dB
Supply-voltage rejection	$-0.2\text{ V} \geq V^- \geq -5.4\text{ V}$	80	96		dB
	$V^+ = 1\text{ V}$, $T_{\text{MIN}} \leq T_J \leq T_{\text{MAX}}$ (see ⁽¹⁾)	74			dB
	$V^+ = 1.2\text{ V}$, $T_{\text{MIN}} \leq T_J \leq T_{\text{MAX}}$ (see ⁽¹⁾)	74			dB
	$1\text{ V} \leq V^+ \leq 6.3\text{ V}$	80	106		dB
	$1.1\text{ V} \leq V^+ \leq 6.3\text{ V}$, $T_{\text{MIN}} \leq T_J \leq T_{\text{MAX}}$ (see ⁽¹⁾)	80	106		dB
	$V^- = 0.2\text{ V}$, $T_{\text{MIN}} \leq T_J \leq T_{\text{MAX}}$ (see ⁽¹⁾)	74			dB
Offset voltage drift			5		μV/°C
Offset current drift			5		pA/°C
Bias current drift			90		pA/°C

(1) These specifications apply for $V^- \leq V_{\text{CM}} \leq V^+ - 0.85\text{ V}$, 1 V ($T_{\text{MIN}} \leq T_J \leq T_{\text{MAX}}$), 1.2 V , 1.3 V ($T_{\text{MIN}} \leq T_J \leq T_{\text{MAX}}$) $< V_S \leq V_{\text{MAX}}$, $V_{\text{REF}} = 0.2\text{ V}$ and $0 \leq I_{\text{REF}} \leq 1\text{ mA}$, unless otherwise specified: $V_{\text{MAX}} = 40\text{ V}$ for the standard part and 6.5 V for the low voltage part. The full-temperature-range operation is -55°C to 125°C for the LM10, -25°C to 85°C for the LM10B(L) and 0°C to 70°C for the LM10C(L). The specifications do not include the effects of thermal gradients ($\tau_1 \approx 20\text{ ms}$), die heating ($\tau_2 \approx 0.2\text{ s}$) or package heating. Gradient effects are small and tend to offset the electrical error (see curves).

(2) For $T_J > 90^\circ\text{C}$, I_{OS} may exceed 1.5 nA for $V_{\text{CM}} = V^-$. With $T_J = 125^\circ\text{C}$ and $V^- \leq V_{\text{CM}} \leq V^- + 0.1\text{ V}$, $I_{\text{OS}} \leq 5\text{ nA}$.

(3) This defines operation in floating applications such as the bootstrapped regulator or two-wire transmitter. Output is connected to the V^+ terminal of the IC and input common mode is referred to V^- (see [System Examples](#)). Effect of larger output-voltage swings with higher load resistance can be accounted for by adding the positive-supply rejection error.

Electrical Characteristics, LM10CL (continued)
 $T_J = 25^\circ\text{C}$ unless otherwise specified.⁽¹⁾

PARAMETER	TEST CONDITIONS	MIN	TYP	MAX	UNIT
Line regulation	$1.2\text{ V} \leq V_S \leq 6.5\text{ V}$		0.001	0.02	%/V
	$1.3\text{ V} \leq V_S \leq 6.5\text{ V}$, $T_{\text{MIN}} \leq T_J \leq T_{\text{MAX}}$ (see ⁽¹⁾)		0.001	0.02	%/V
	$0 \leq I_{\text{REF}} \leq 0.5\text{ mA}$, $V_{\text{REF}} = 200\text{ mV}$, $T_{\text{MIN}} \leq T_J \leq T_{\text{MAX}}$ (see ⁽¹⁾)			0.03	%/V
Load regulation	$0 \leq I_{\text{REF}} \leq 0.5\text{ mA}$		0.01%	0.15%	
	$V^+ - V_{\text{REF}} \geq 1\text{ V}$, $T_{\text{MIN}} \leq T_J \leq T_{\text{MAX}}$ (see ⁽¹⁾)			0.2%	
	$V^+ - V_{\text{REF}} \geq 1.1\text{ V}$, $T_{\text{MIN}} \leq T_J \leq T_{\text{MAX}}$ (see ⁽¹⁾)			0.2%	
Amplifier gain	$0.2\text{ V} \leq V_{\text{REF}} \leq 5.5\text{ V}$	$T_J = 25^\circ\text{C}$	20	70	V/mV
		$T_{\text{MIN}} \leq T_J \leq T_{\text{MAX}}$ (see ⁽¹⁾)	15		V/mV
Feedback sense voltage	$T_J = 25^\circ\text{C}$	190	200	210	mV
	$T_{\text{MIN}} \leq T_J \leq T_{\text{MAX}}$ (see ⁽¹⁾)	189		211	mV
Feedback current	$T_J = 25^\circ\text{C}$		22	75	nA
	$T_{\text{MIN}} \leq T_J \leq T_{\text{MAX}}$ (see ⁽¹⁾)			90	nA
Reference drift			0.003		%/°C
Supply current	$T_J = 25^\circ\text{C}$		280	500	μA
	$T_{\text{MIN}} \leq T_J \leq T_{\text{MAX}}$ (see ⁽¹⁾)			570	μA

6.8 Typical Characteristics

6.8.1 Typical Characteristics (Op Amp)

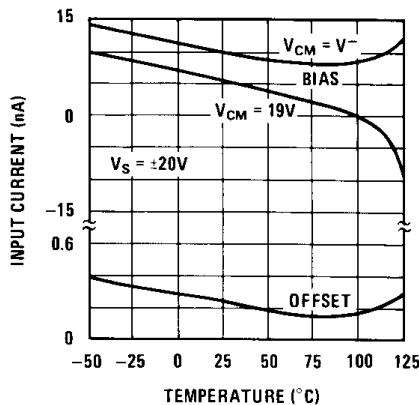

Figure 1. Input Current

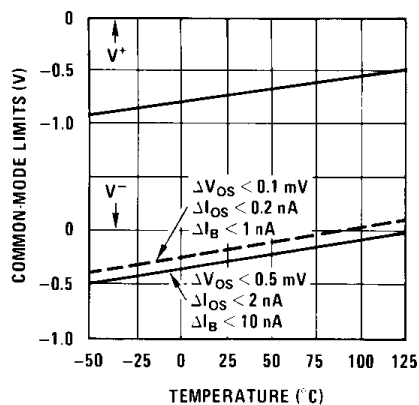

Figure 2. Common-Mode Limits

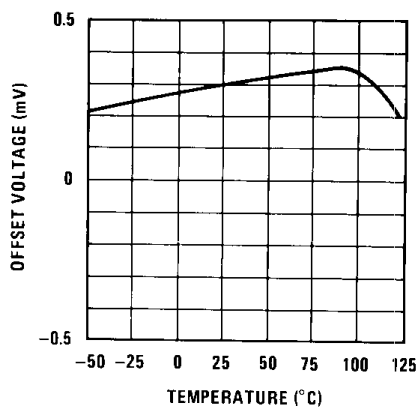

Figure 3. Output Voltage Drift

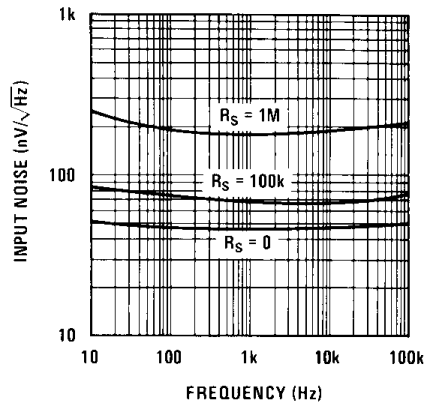

Figure 4. Input Noise Voltage

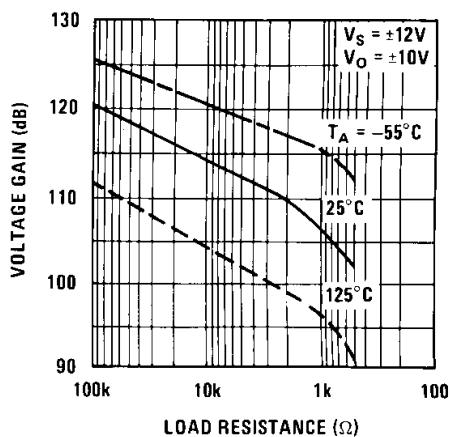

Figure 5. DC Voltage Gain

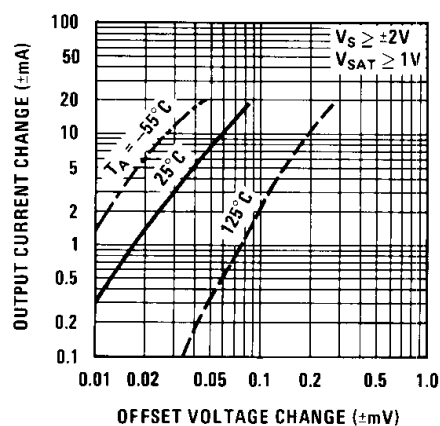

Figure 6. Transconductance

Typical Characteristics (Op Amp) (continued)

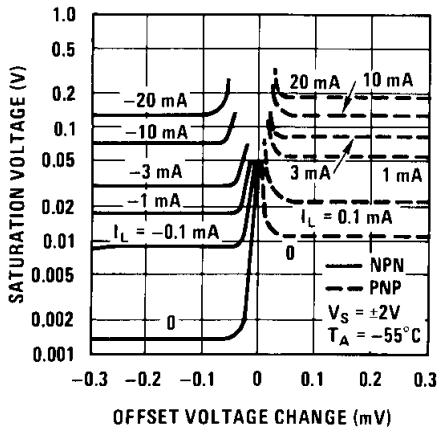

Figure 7. Output Saturation Characteristics

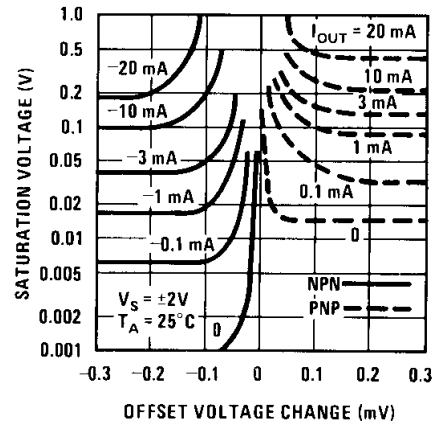

Figure 8. Output Saturation Characteristics

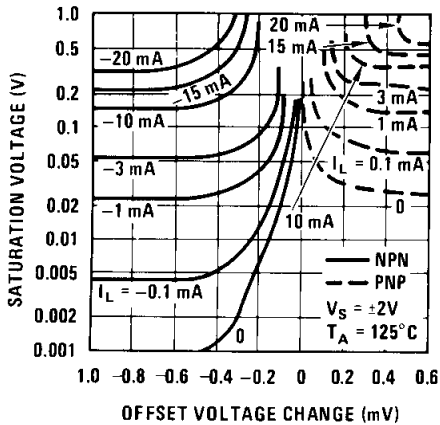

Figure 9. Output Saturation Characteristics

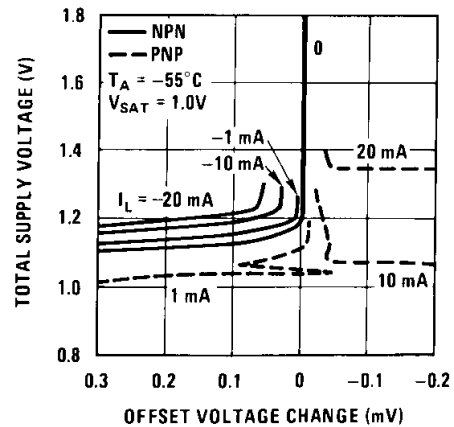

Figure 10. Minimum Supply Voltage

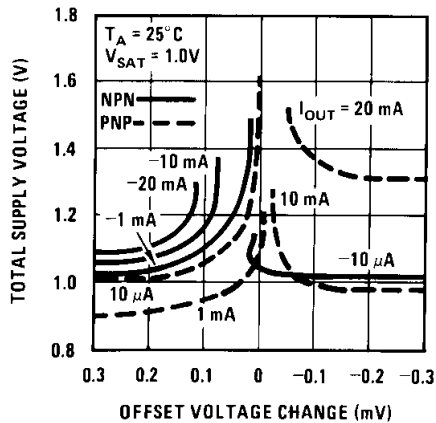

Figure 11. Minimum Supply Voltage

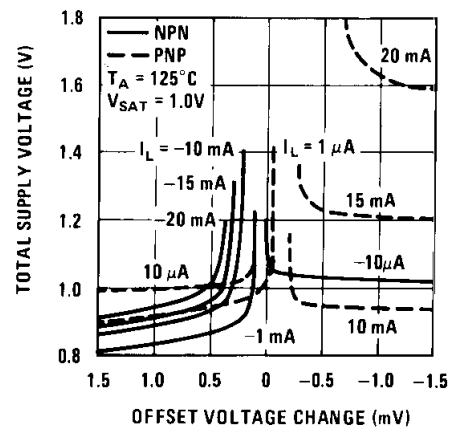

Figure 12. Minimum Supply Voltage

Typical Characteristics (Op Amp) (continued)

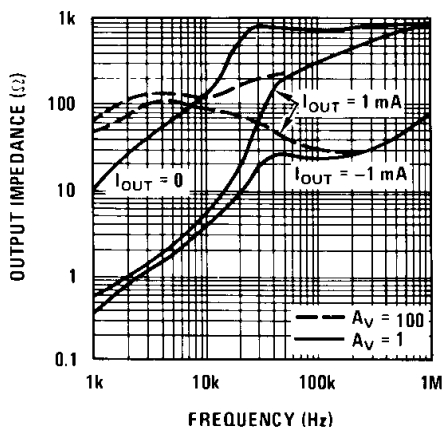

Figure 13. Output Impedance

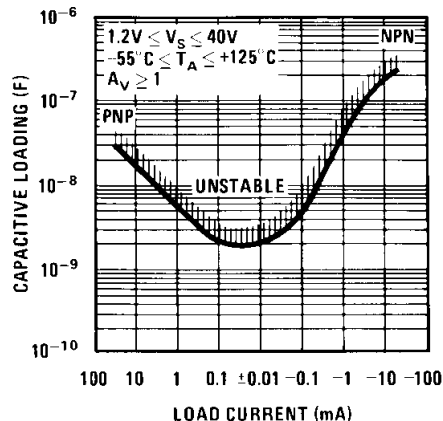

Figure 14. Typical Stability Range

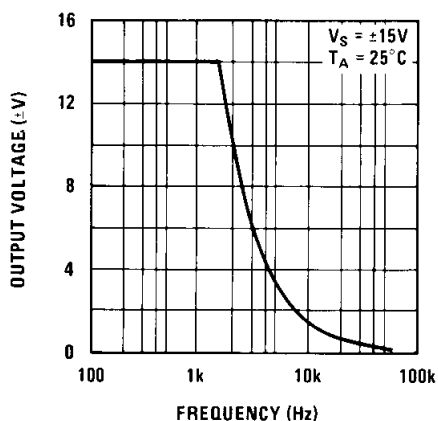

Figure 15. Large Signal Response

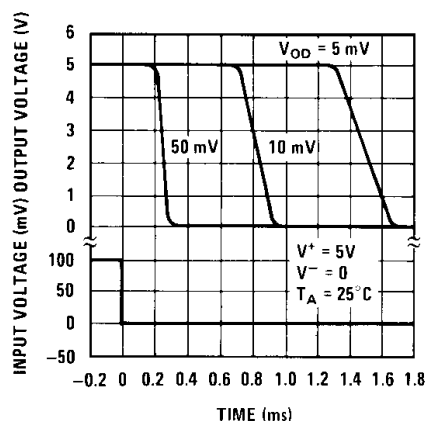

Figure 16. Comparator Response Time For Various Input Overdrives

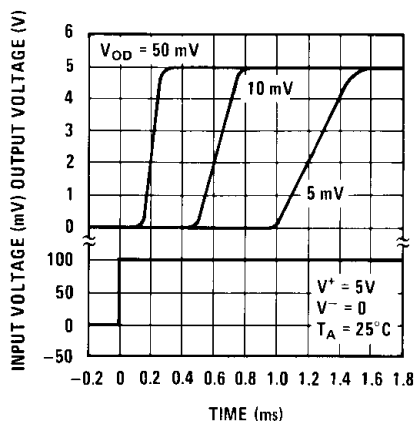

Figure 17. Comparator Response Time For Various Input Overdrives

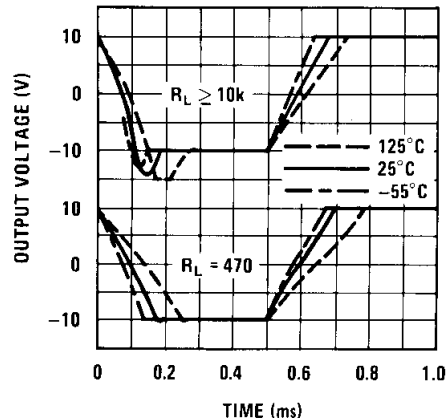

Figure 18. Follower Pulse Response

Typical Characteristics (Op Amp) (continued)

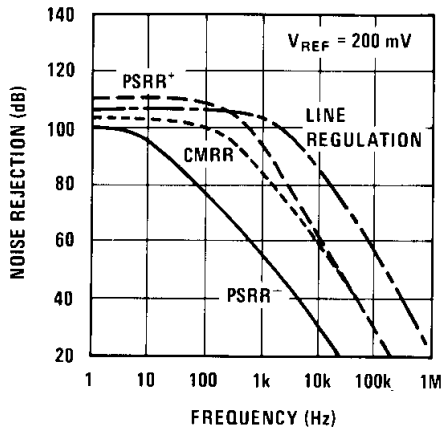

Figure 19. Noise Rejection

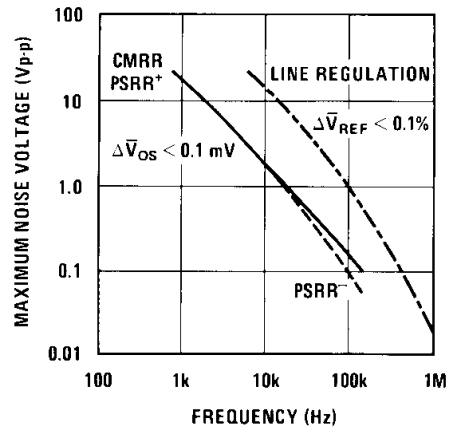

Figure 20. Rejection Slew Limiting

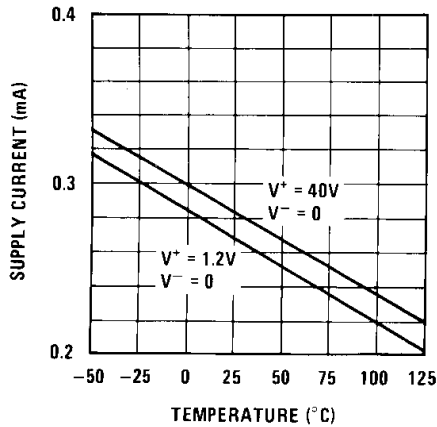

Figure 21. Supply Current

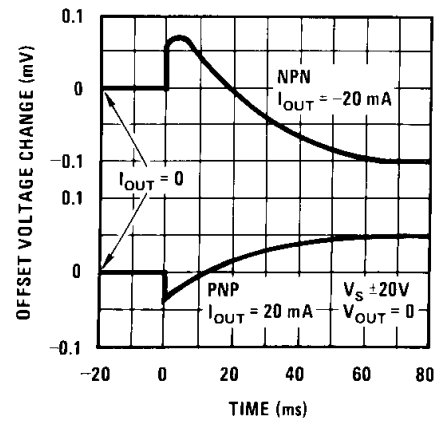

Figure 22. Thermal Gradient Feedback

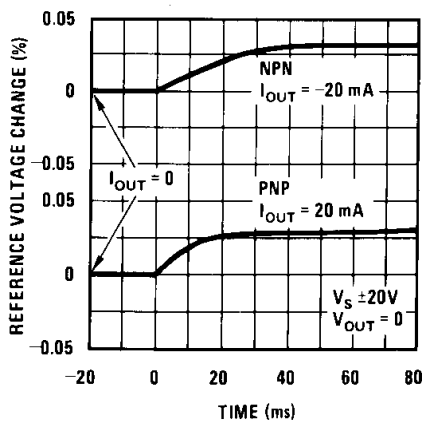

Figure 23. Thermal Gradient Cross-Coupling

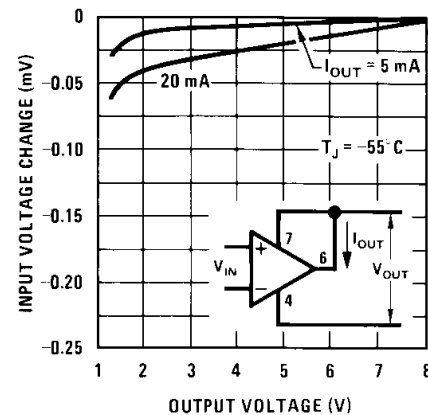

Figure 24. Shunt Gain

Typical Characteristics (Op Amp) (continued)

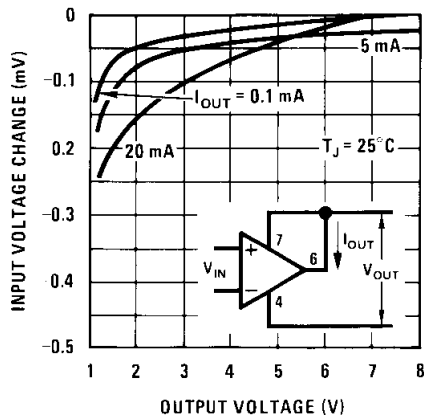

Figure 25. Shunt Gain

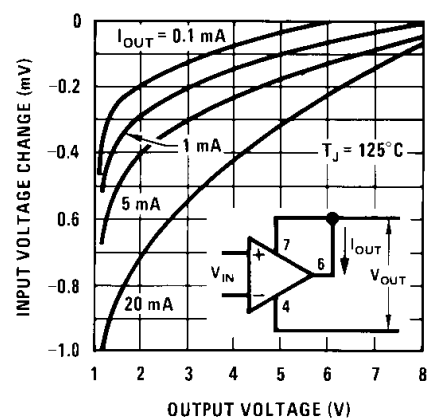

Figure 26. Shunt Gain

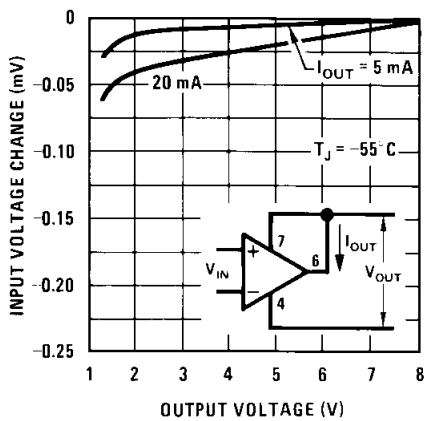

Figure 27. Shunt Gain

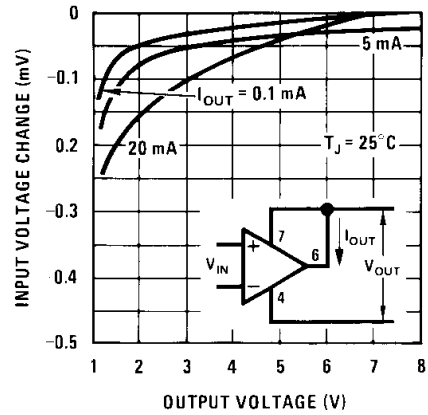

Figure 28. Shunt Gain

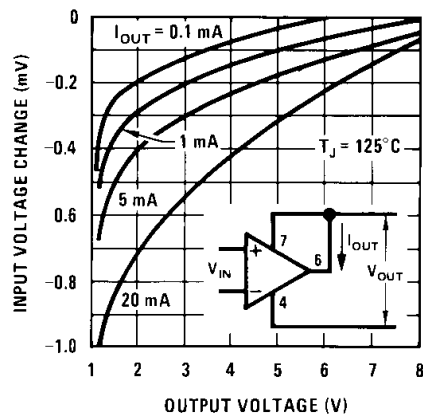

Figure 29. Shunt Gain

6.8.2 Typical Characteristics (Reference)

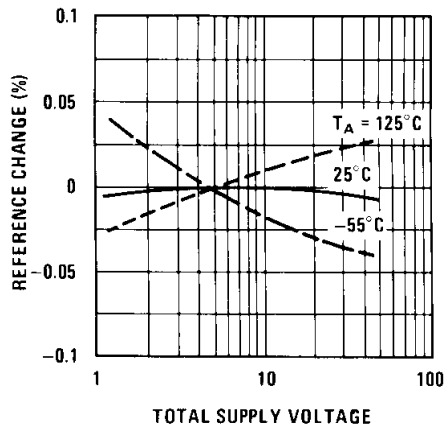

Figure 30. Line Regulation

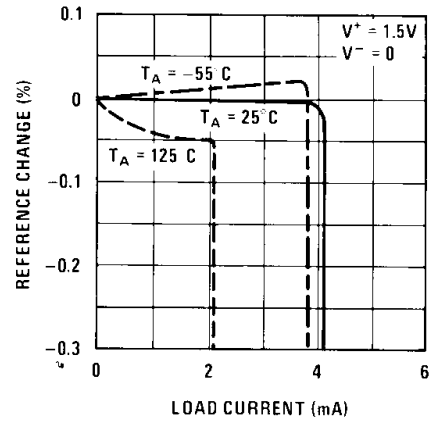

Figure 31. Load Regulation

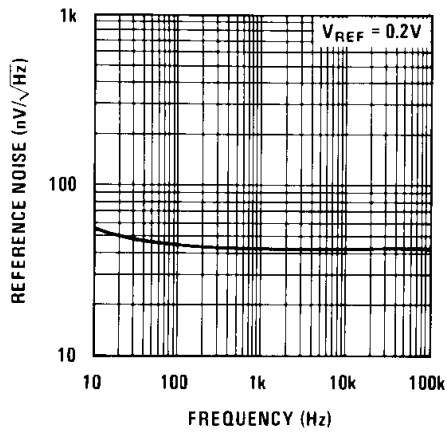

Figure 32. Reference Noise Voltage

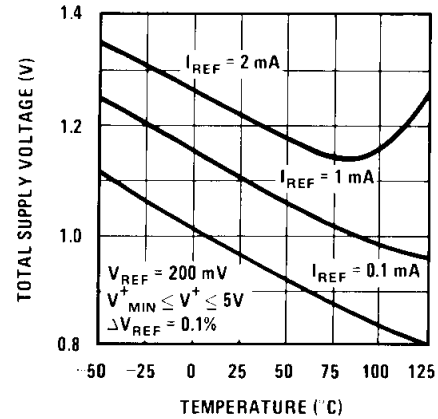

Figure 33. Minimum Supply Voltage

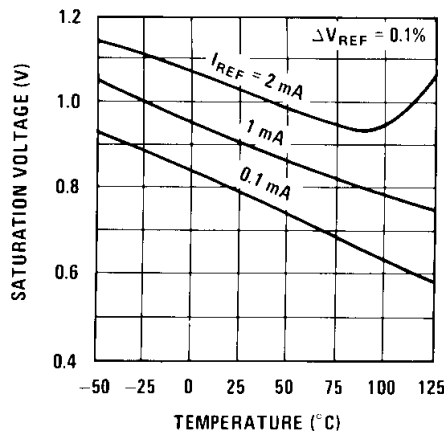

Figure 34. Output Saturation

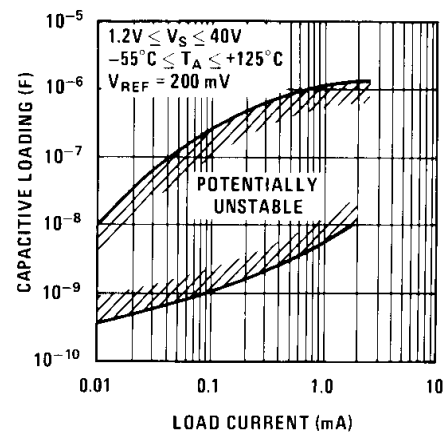

Figure 35. Typical Stability Range

7 Detailed Description

7.1 Overview

The LM10 is a dual-operational amplifier combined with a voltage reference capable of a single-supply operation down to 1.1 V. It provides high overall performance, making it ideal for many general-purpose applications. The circuit can also operate in a floating mode, powered by residual voltage, independent of fixed supplies and it is well-protected from temperature drift.

7.2 Functional Block Diagram

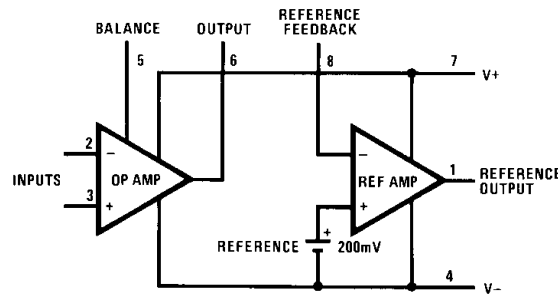

7.3 Feature Description

7.3.1 Operating Characteristics

The LM10 is specified for operation from 1.2 V to 40 V. Many of the specifications apply from -55°C to 125°C . Parameters that can exhibit significant variance with regard to operating voltage or temperature are presented in electrical characteristics tables under [Specifications](#) and in the [Typical Characteristics](#) section.

7.3.2 Common-Mode Voltage Range

The input common-mode voltage range of the LM10 extends from the negative rail to 0.85 V less than the positive rail.

7.3.3 Operational Amplifier

The minimum operating voltage is reduced to nearly one volt and the current gain is less affected by temperature, resulting in a fairly flat bias current over temperature.

7.3.4 Voltage Reference

Second-order nonlinearities are compensated for which eliminates the bowed characteristics of conventional designs, resulting in better temperature stability.

7.4 Device Functional Modes

7.4.1 Floating Mode

To use the device in a floating mode, the operational amplifier output is shorted to V_{+} which disables the PNP portion of the output stage. Thus, with a positive input signal, neither halves of the output conducts and the current between the supply terminals is equal to the quiescent supply current. With negative input signals, the NPN portion of the output begins to turn on, reaching the short circuit current for a few hundred microvolts overdrive.

7.4.2 Linear Operation

This device can also operate linearly while in the floating mode. An example of this is shown in the [Typical Application](#) section.

8 Application and Implementation

NOTE

Information in the following applications sections is not part of the TI component specification, and TI does not warrant its accuracy or completeness. TI's customers are responsible for determining suitability of components for their purposes. Customers should validate and test their design implementation to confirm system functionality.

8.1 Application Information

With heavy amplifier loading to V^- , resistance drops in the V^- lead can adversely affect reference regulation. Lead resistance can approach $1\ \Omega$. Therefore, the common to the reference circuitry should be connected as close as possible to the package.

8.2 Typical Application

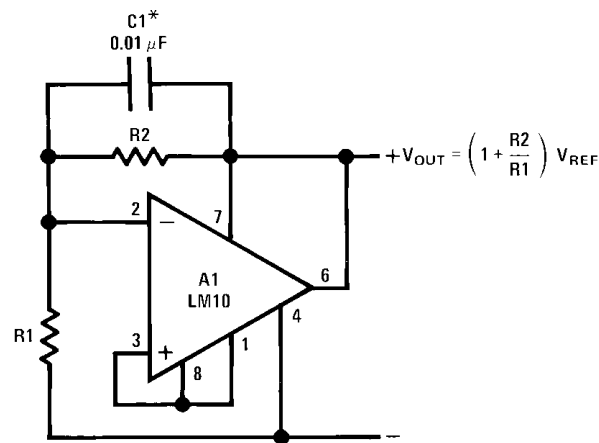

* required for capacitive loading

Figure 36. Shunt Voltage Regulator

8.2.1 Design Requirements

Table 1 lists the design parameters for this example.

Table 1. Design Parameters

DESIGN PARAMETERS	EXAMPLE VALUE
Ambient Temperature Range	-55°C to 125°C
Supply Voltage Range	1.2 V to 40 V
Common-Mode Input Range	(V^-) to $(V^+) - 0.85\ \text{V}$

8.2.2 Detailed Design Procedure

Given that the transfer function of this circuit is:

$$V_{OUT} = \left(1 + \frac{R_2}{R_1}\right) V_{REF} \quad (1)$$

the output can be set between 0.2 V and the breakdown voltage of the IC by selecting an appropriate value for R2. The circuit regulates for input voltages within a saturation drop of the output (typically 0.4 V at 20 mA and 0.15 V at 5 mA). The regulator is protected from shorts or overloads by current limiting and thermal shutdown.

Typical regulation is about 0.05% load and 0.003%/V line. A substantial improvement in regulation can be effected by connecting the operational amplifier as a follower and setting the reference to the desired output voltage. This has the disadvantage that the minimum input-output differential is increased to a little more than a diode drop. If the operational amplifier were connected for a gain of 2, the output could again saturate. But this requires an additional pair of precision resistors.

The regulator in Figure 36 could be made adjustable to zero by connecting the operational amplifier to a potentiometer on the reference output. This has the disadvantage that the regulation at the lower voltage settings is not as good as it might otherwise be.

8.2.3 Application Curve

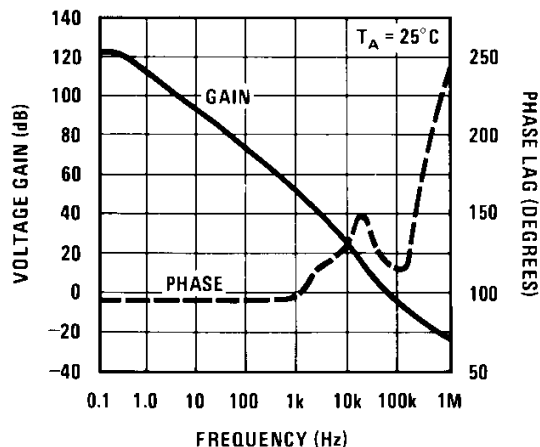

Figure 37. Frequency Response

8.3 System Examples

Circuit descriptions available in application note AN-211 ([SNOA638](#)).

8.3.1 Operational Amplifier Offset Adjustment

(Pin numbers are for 8-pin packages)

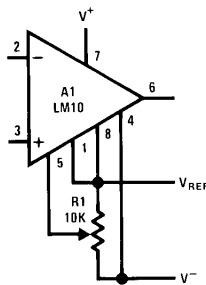

Figure 38. Standard

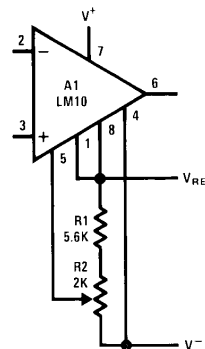

Figure 39. Limited Range

System Examples (continued)

(Pin numbers are for 8-pin packages)

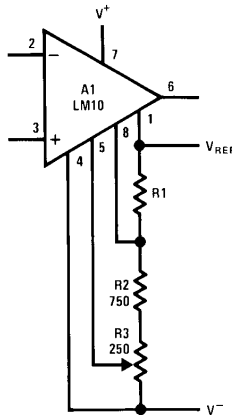

Figure 40. Limited Range With Boosted Reference

8.3.2 Positive Regulators

(Pin numbers are for 8-pin packages)

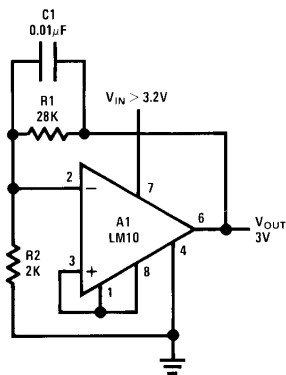

Figure 41. Low Voltage

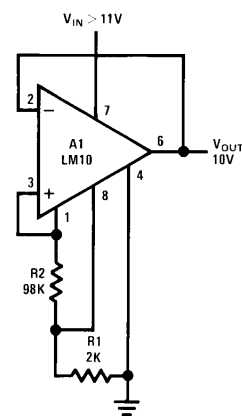
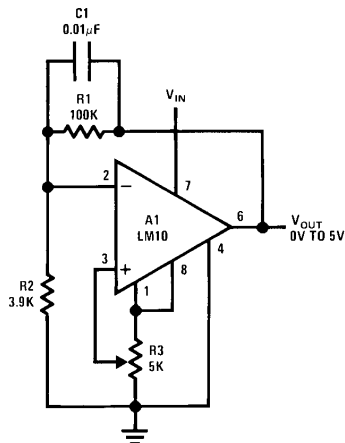

Figure 42. Best Regulation



Use only electrolytic output capacitors.

Figure 43. Zero Output

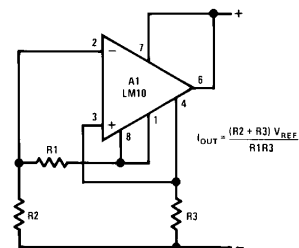
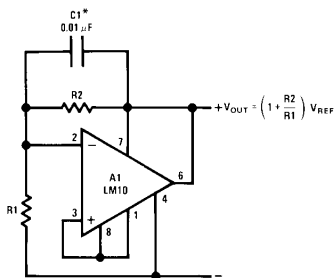

Figure 44. Current Regulator

System Examples (continued)

(Pin numbers are for 8-pin packages)



Required For Capacitive Loading

Figure 45. Shunt Regulator

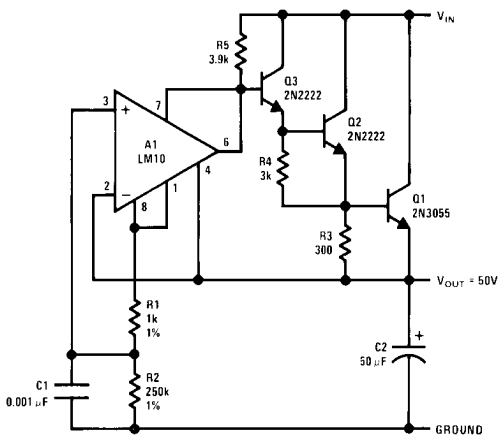
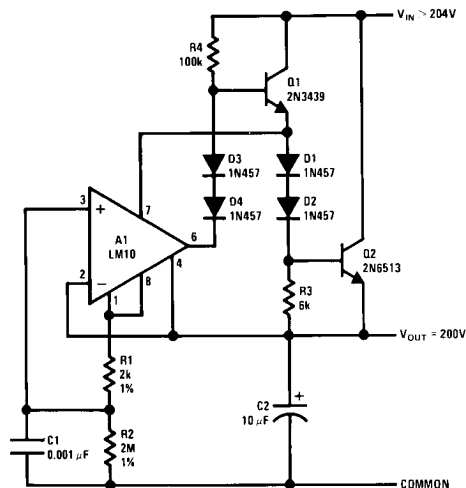
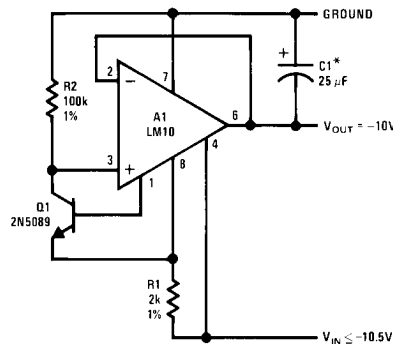

Figure 47. Precision Regulator



$$V_{OUT} = \frac{R_2}{R_1} V_{REF}$$

Figure 49. HV Regulator



*Electrolytic

Figure 46. Negative Regulator

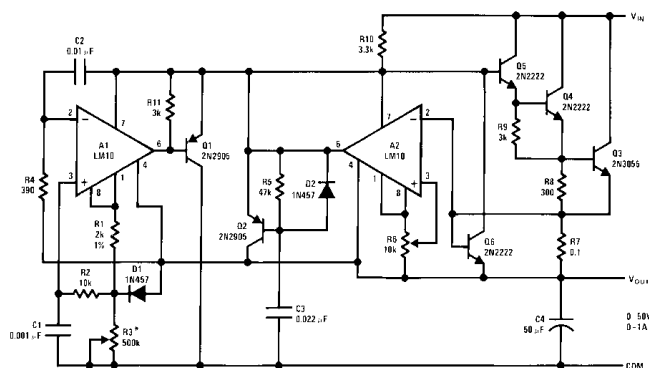

$$*V_{OUT} = 10^{-4} R_3$$

Figure 48. Laboratory Power Supply

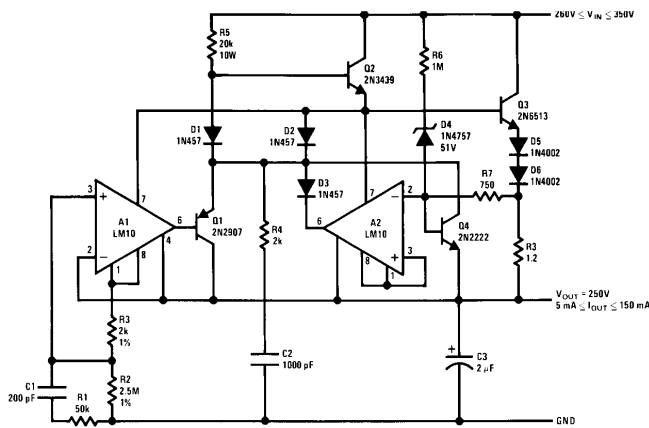

Figure 50. Protected HV Regulator

LM10

SNOSBH4E – MAY 1998 – REVISED OCTOBER 2015

www.ti.com

System Examples (continued)

(Pin numbers are for 8-pin packages)

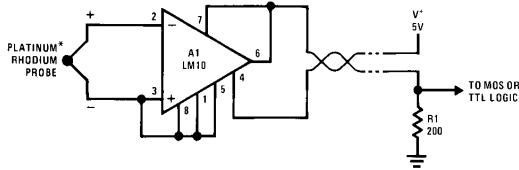

*800°C Threshold Is Established By Connecting Balance To V_{REF} .

Figure 51. Flame Detector

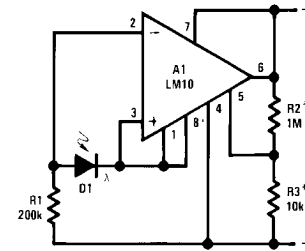

*Provides Hysteresis

Figure 52. Light Level Sensor

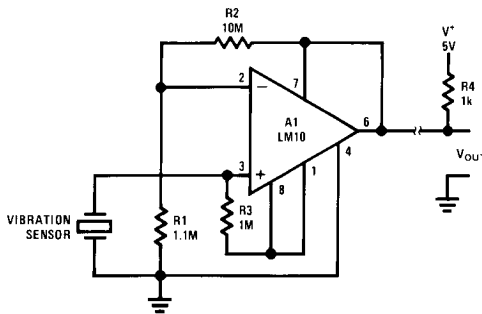

Figure 53. Remote Amplifier

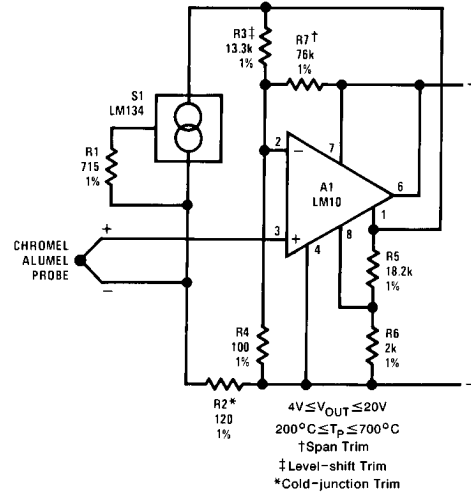

Figure 54. Remote Thermocouple Amplifier

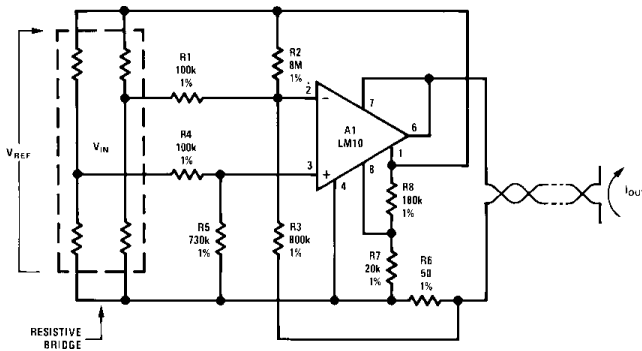

Figure 55. Transmitter for Bridge Sensor

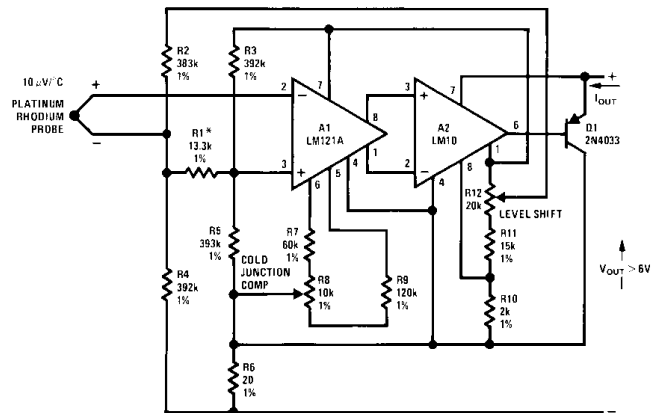

Figure 56. Precision Thermocouple Transmitter

System Examples (continued)

(Pin numbers are for 8-pin packages)

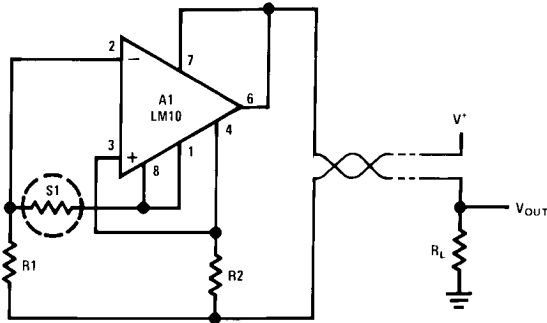
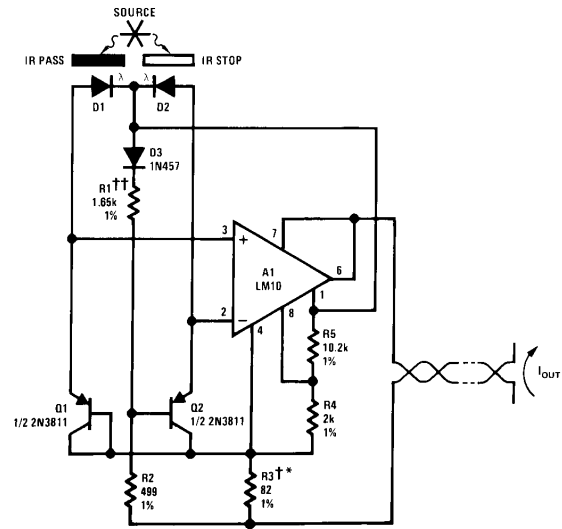
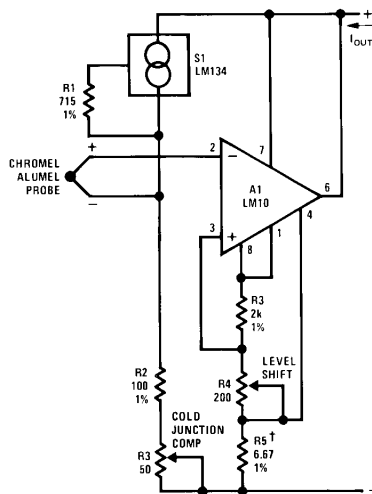

Figure 57. Resistance Thermometer Transmitter



††Level-shift Trim
*Scale Factor Trim
†Copper Wire Wound
 $1 \text{ mA} \leq I_{OUT} \leq 5 \text{ mA}$
 $0.01 \leq \frac{I_{D2}}{I_{D1}} \leq 100$

Figure 58. Optical Pyrometer



$200^{\circ}\text{C} \leq T_p \leq 700^{\circ}\text{C}$
 $1 \text{ mA} \leq I_{OUT} \leq 5 \text{ mA}$
†Gain Trim

Figure 59. Thermocouple Transmitter

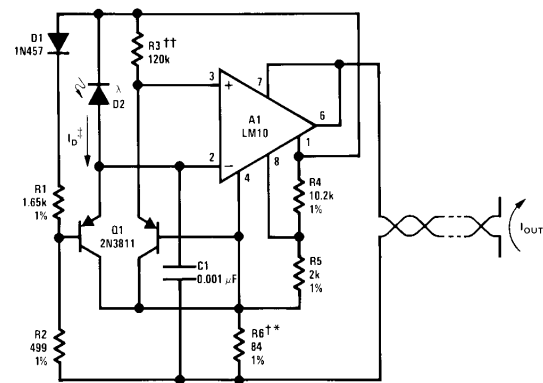

$1 \text{ mA} \leq I_{OUT} \leq 5 \text{ mA}$
 $\pm 50 \mu\text{A} \leq I_D \leq 500 \mu\text{A}$
††Center Scale Trim
†Scale Factor Trim
*Copper Wire Wound

Figure 60. Logarithmic Light Sensor

System Examples (continued)

(Pin numbers are for 8-pin packages)

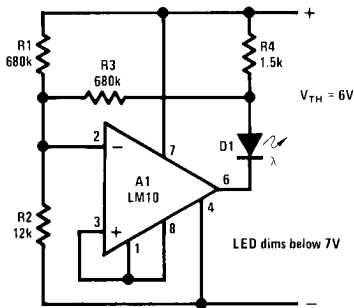

Figure 61. Battery-level Indicator

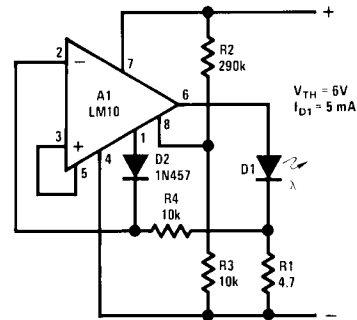
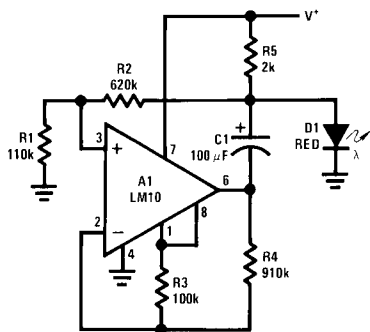
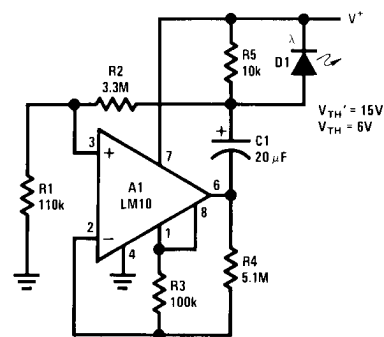

Figure 62. Battery-threshold Indicator



Flashes Above 1.2V
Rate Increases With
Voltage

Figure 63. Single-cell Voltage Monitor



Flash Rate Increases
Above 6V and Below 15V

Figure 64. Double-ended Voltage Monitor

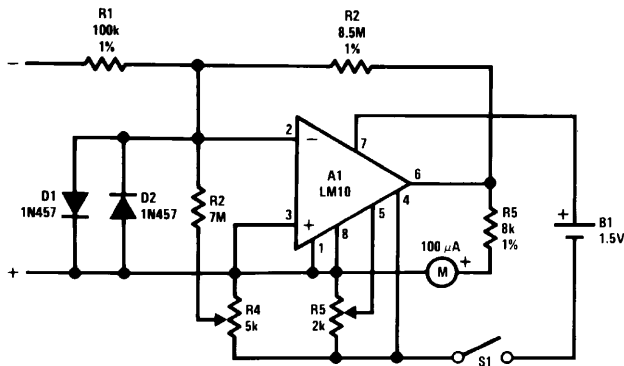

INPUT
10 mV, 100nA
FULL-SCALE

Figure 65. Meter Amplifier

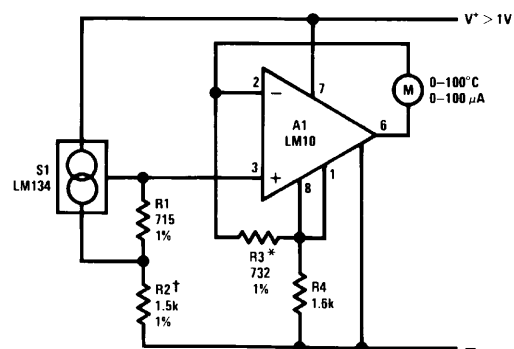

*Trim For Span
†Trim For Zero

Figure 66. Thermometer

System Examples (continued)

(Pin numbers are for 8-pin packages)

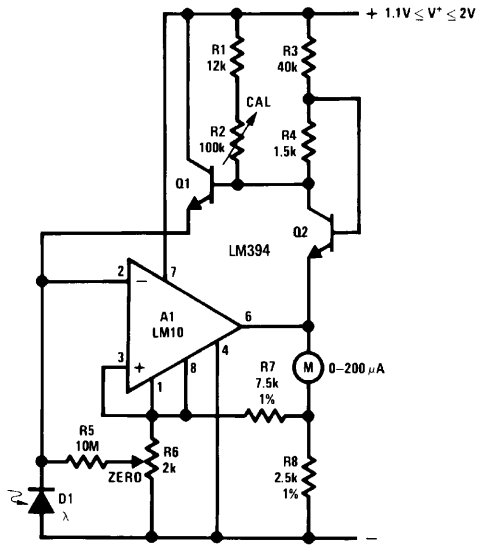

$1 \leq \lambda/\lambda_0 \leq 10^5$

Figure 67. Light Meter

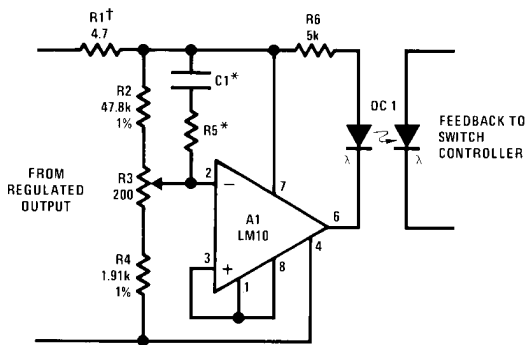

†Controls "Loop Gain"
*Optional Frequency Shaping

Figure 69. Isolated Voltage Sensor

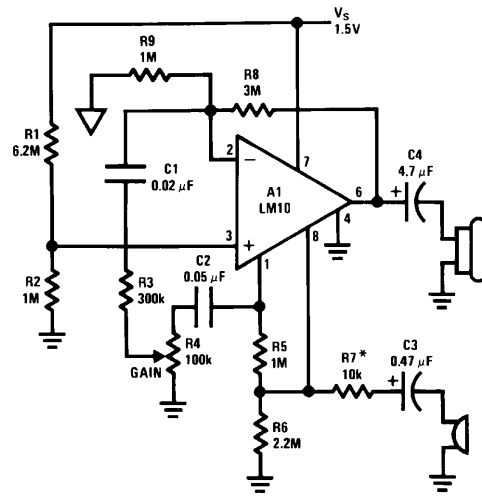

$Z_{OUT} \sim 680\Omega @ 5\text{ kHz}$
 $A_V \leq 1k$
 $f_1 \sim 100\text{ Hz}$
 $f_2 \sim 5\text{ kHz}$
 $R_L \sim 500$
*Max Gain Trim

Figure 68. Microphone Amplifier

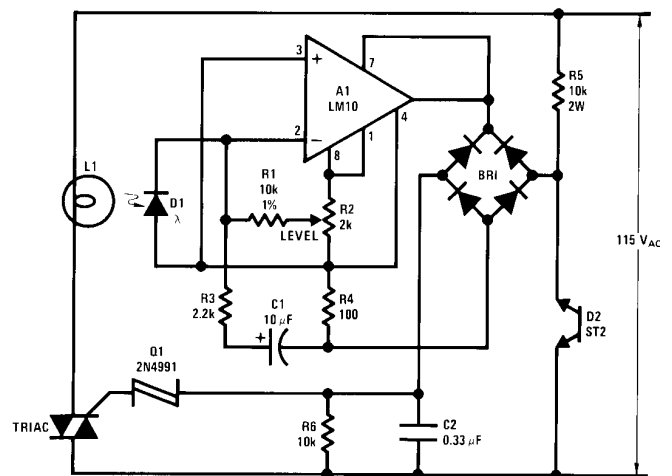

Figure 70. Light-Level Controller

System Examples (continued)

(Pin numbers are for 8-pin packages)

8.3.3 Reference and Internal Regulator

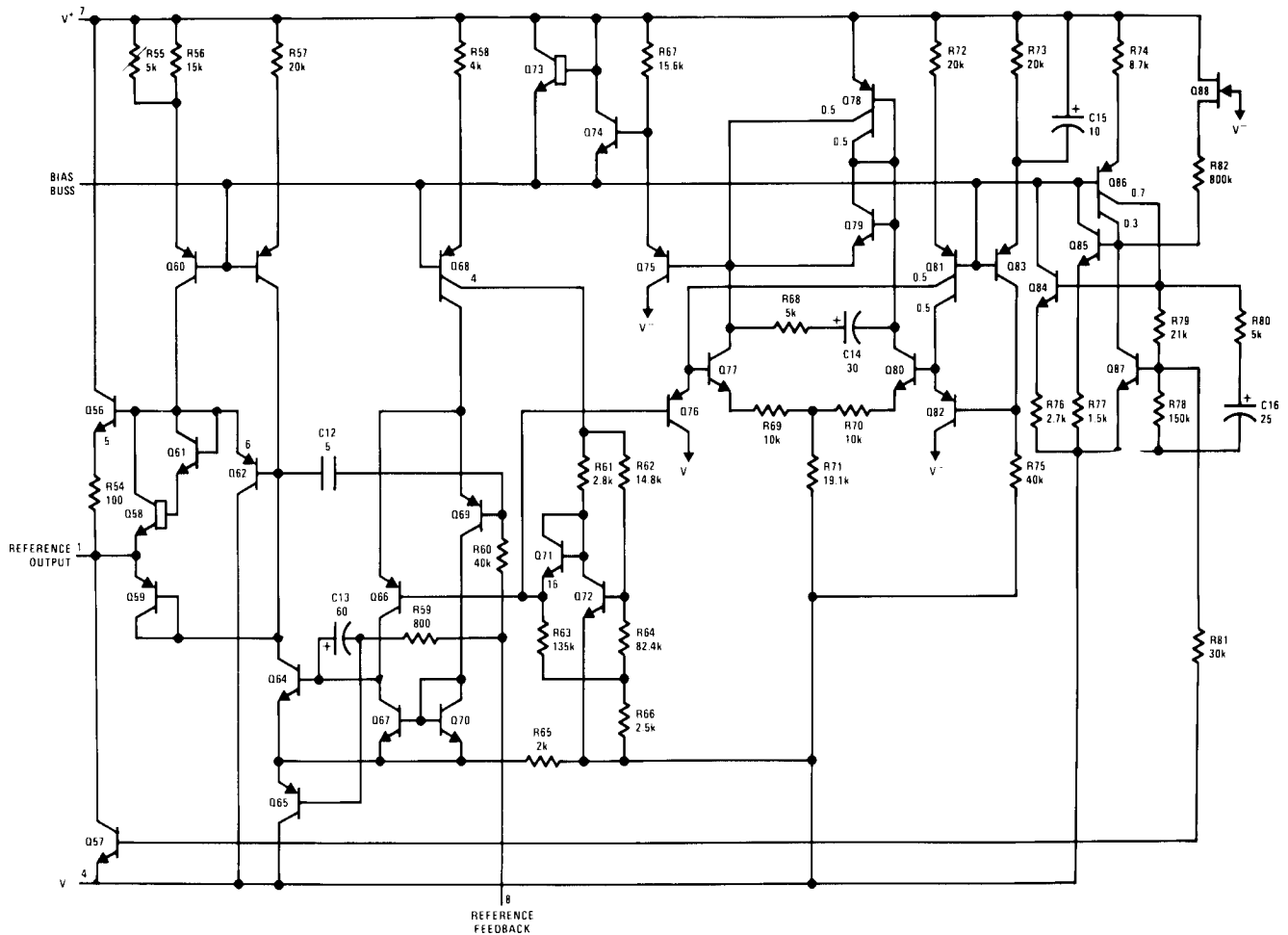

Figure 71. Reference and Internal Regulator

9 Power Supply Recommendations

The LM10 is specified for operation from 1.2 V to 40 V unless otherwise stated. Many specifications apply from -55°C to 125°C . Parameters that can exhibit significant variance with regard to operating voltage or temperature are presented in the *Specifications* section.

CAUTION

Supply voltages larger than 40 V can permanently damage the device; see the *Absolute Maximum Ratings* table.

10 Layout

10.1 Layout Guidelines

For best operational performance of the device, good printed-circuit board (PCB) layout practices are recommended. Low-loss, 0.1- μF bypass capacitors should be connected between each supply pin and ground, placed as close to the device as possible. A single bypass capacitor from $V+$ to ground is applicable to single-supply applications.

10.2 Layout Example

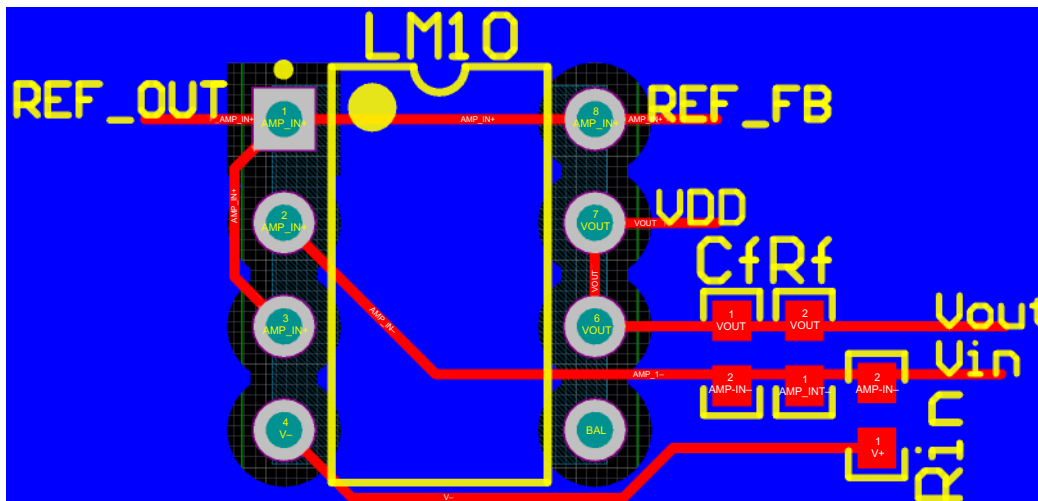

Figure 72. Layout Example

11 Device and Documentation Support

11.1 Device Support

11.1.1 Device Nomenclature

11.1.1.1 Definition of Terms

Input offset voltage: That voltage which must be applied between the input terminals to bias the unloaded output in the linear region.

Input offset current: The difference in the currents at the input terminals when the unloaded output is in the linear region.

Input bias current: The absolute value of the average of the two input currents.

Input resistance: The ratio of the change in input voltage to the change in input current on either input with the other grounded.

Large signal voltage gain: The ratio of the specified output voltage swing to the change in differential input voltage required to produce it.

Shunt gain: The ratio of the specified output voltage swing to the change in differential input voltage required to produce it with the output tied to the V^+ terminal of the IC. The load and power source are connected between the V^+ and V^- terminals, and input common-mode is referred to the V^- terminal.

Common-mode rejection: The ratio of the input voltage range to the change in offset voltage between the extremes.

Supply-voltage rejection: The ratio of the specified supply-voltage change to the change in offset voltage between the extremes.

Line regulation: The average change in reference output voltage over the specified supply voltage range.

Load regulation: The change in reference output voltage from no load to that load specified.

Feedback sense voltage: The voltage, referred to V^- , on the reference feedback terminal while operating in regulation.

Reference amplifier gain: The ratio of the specified reference output change to the change in feedback sense voltage required to produce it.

Feedback current: The absolute value of the current at the feedback terminal when operating in regulation.

Supply current: The current required from the power source to operate the amplifier and reference with their outputs unloaded and operating in the linear range.

11.2 Documentation Support

11.2.1 Related Documentation

For related documentation, see the following:

AN-211 New Op Amp Ideas, [SNOA638](#)

11.3 Community Resources

The following links connect to TI community resources. Linked contents are provided "AS IS" by the respective contributors. They do not constitute TI specifications and do not necessarily reflect TI's views; see TI's [Terms of Use](#).

TI E2E™ Online Community *TI's Engineer-to-Engineer (E2E) Community*. Created to foster collaboration among engineers. At [e2e.ti.com](#), you can ask questions, share knowledge, explore ideas and help solve problems with fellow engineers.

Design Support *TI's Design Support* Quickly find helpful E2E forums along with design support tools and contact information for technical support.

11.4 Trademarks

E2E is a trademark of Texas Instruments.
All other trademarks are the property of their respective owners.

11.5 Electrostatic Discharge Caution



These devices have limited built-in ESD protection. The leads should be shorted together or the device placed in conductive foam during storage or handling to prevent electrostatic damage to the MOS gates.

11.6 Glossary

[SLYZ022](#) — *TI Glossary*.

This glossary lists and explains terms, acronyms, and definitions.

12 Mechanical, Packaging, and Orderable Information

The following pages include mechanical, packaging, and orderable information. This information is the most current data available for the designated devices. This data is subject to change without notice and revision of this document. For browser-based versions of this data sheet, refer to the left-hand navigation.

PACKAGING INFORMATION

Orderable Device	Status (1)	Package Type	Package Drawing	Pins	Package Qty	Eco Plan (2)	Lead/Ball Finish (6)	MSL Peak Temp (3)	Op Temp (°C)	Device Marking (4/5)	Samples
LM10BH	ACTIVE	TO-99	LMC	8	500	TBD	Call TI	Call TI	-40 to 85	(LM10BH ~ LM10BH)	Samples
LM10BH/NOPB	ACTIVE	TO-99	LMC	8	500	Green (RoHS & no Sb/Br)	Call TI	Level-1-NA-UNLIM	-40 to 85	(LM10BH ~ LM10BH)	Samples
LM10CH	ACTIVE	TO-99	LMC	8	500	TBD	Call TI	Call TI	0 to 70	(LM10CH ~ LM10CH)	Samples
LM10CH/NOPB	ACTIVE	TO-99	LMC	8	500	Green (RoHS & no Sb/Br)	Call TI	Level-1-NA-UNLIM	0 to 70	(LM10CH ~ LM10CH)	Samples
LM10CLN/NOPB	ACTIVE	PDIP	P	8	40	Green (RoHS & no Sb/Br)	CU SN	Level-1-NA-UNLIM	0 to 70	LM10CLN	Samples
LM10CN/NOPB	ACTIVE	PDIP	P	8	40	Green (RoHS & no Sb/Br)	CU SN	Level-1-NA-UNLIM	0 to 70	LM 10CN	Samples
LM10CWM	NRND	SOIC	NPA	14	50	TBD	Call TI	Call TI	0 to 70	LM10CWM	
LM10CWM/NOPB	ACTIVE	SOIC	NPA	14	50	Green (RoHS & no Sb/Br)	CU SN	Level-3-260C-168 HR	0 to 70	LM10CWM	Samples
LM10CWMX/NOPB	ACTIVE	SOIC	NPA	14	1000	Green (RoHS & no Sb/Br)	CU SN	Level-3-260C-168 HR	0 to 70	LM10CWM	Samples

(1) The marketing status values are defined as follows:

ACTIVE: Product device recommended for new designs.

LIFEBUY: TI has announced that the device will be discontinued, and a lifetime-buy period is in effect.

NRND: Not recommended for new designs. Device is in production to support existing customers, but TI does not recommend using this part in a new design.

PREVIEW: Device has been announced but is not in production. Samples may or may not be available.

OBSOLETE: TI has discontinued the production of the device.

(2) Eco Plan - The planned eco-friendly classification: Pb-Free (RoHS), Pb-Free (RoHS Exempt), or Green (RoHS & no Sb/Br) - please check <http://www.ti.com/productcontent> for the latest availability information and additional product content details.

TBD: The Pb-Free/Green conversion plan has not been defined.

Pb-Free (RoHS): TI's terms "Lead-Free" or "Pb-Free" mean semiconductor products that are compatible with the current RoHS requirements for all 6 substances, including the requirement that lead not exceed 0.1% by weight in homogeneous materials. Where designed to be soldered at high temperatures, TI Pb-Free products are suitable for use in specified lead-free processes.

Pb-Free (RoHS Exempt): This component has a RoHS exemption for either 1) lead-based flip-chip solder bumps used between the die and package, or 2) lead-based die adhesive used between the die and leadframe. The component is otherwise considered Pb-Free (RoHS compatible) as defined above.

Green (RoHS & no Sb/Br): TI defines "Green" to mean Pb-Free (RoHS compatible), and free of Bromine (Br) and Antimony (Sb) based flame retardants (Br or Sb do not exceed 0.1% by weight in homogeneous material)

(3) MSL, Peak Temp. - The Moisture Sensitivity Level rating according to the JEDEC industry standard classifications, and peak solder temperature.

(4) There may be additional marking, which relates to the logo, the lot trace code information, or the environmental category on the device.

(5) Multiple Device Markings will be inside parentheses. Only one Device Marking contained in parentheses and separated by a "~" will appear on a device. If a line is indented then it is a continuation of the previous line and the two combined represent the entire Device Marking for that device.

(6) Lead/Ball Finish - Orderable Devices may have multiple material finish options. Finish options are separated by a vertical ruled line. Lead/Ball Finish values may wrap to two lines if the finish value exceeds the maximum column width.

Important Information and Disclaimer:The information provided on this page represents TI's knowledge and belief as of the date that it is provided. TI bases its knowledge and belief on information provided by third parties, and makes no representation or warranty as to the accuracy of such information. Efforts are underway to better integrate information from third parties. TI has taken and continues to take reasonable steps to provide representative and accurate information but may not have conducted destructive testing or chemical analysis on incoming materials and chemicals. TI and TI suppliers consider certain information to be proprietary, and thus CAS numbers and other limited information may not be available for release.

In no event shall TI's liability arising out of such information exceed the total purchase price of the TI part(s) at issue in this document sold by TI to Customer on an annual basis.

TAPE AND REEL INFORMATION

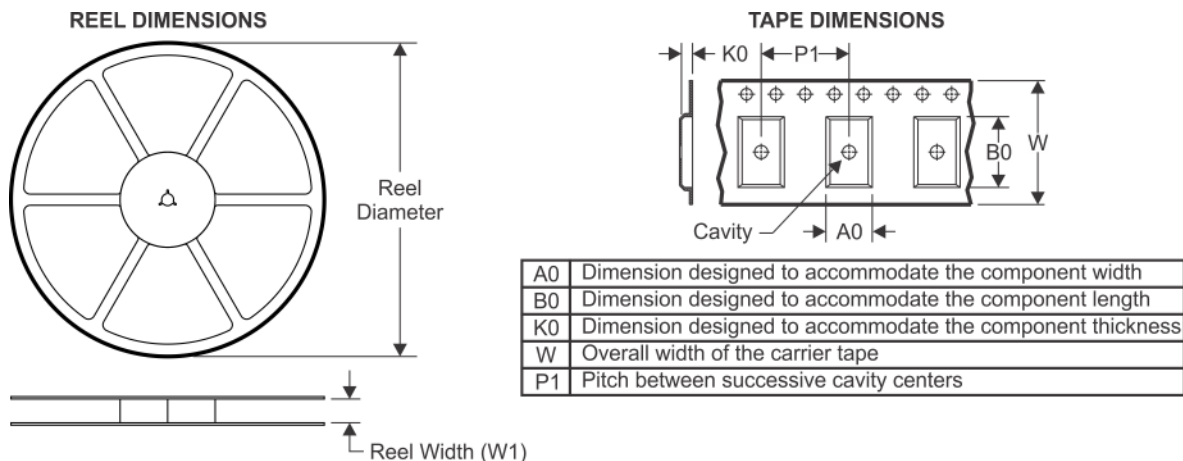

QUADRANT ASSIGNMENTS FOR PIN 1 ORIENTATION IN TAPE

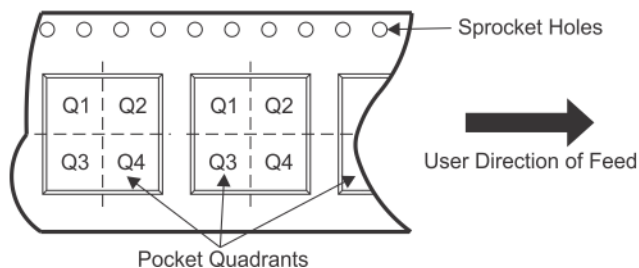

*All dimensions are nominal

Device	Package Type	Package Drawing	Pins	SPQ	Reel Diameter (mm)	Reel Width W1 (mm)	A0 (mm)	B0 (mm)	K0 (mm)	P1 (mm)	W (mm)	Pin1 Quadrant
LM10CWMX/NOPB	SOIC	NPA	14	1000	330.0	16.4	10.9	9.5	3.2	12.0	16.0	Q1

TAPE AND REEL BOX DIMENSIONS



*All dimensions are nominal

Device	Package Type	Package Drawing	Pins	SPQ	Length (mm)	Width (mm)	Height (mm)
LM10CWMX/NOPB	SOIC	NPA	14	1000	367.0	367.0	38.0

LMC (O-MBCY-W8)

METAL CYLINDRICAL PACKAGE

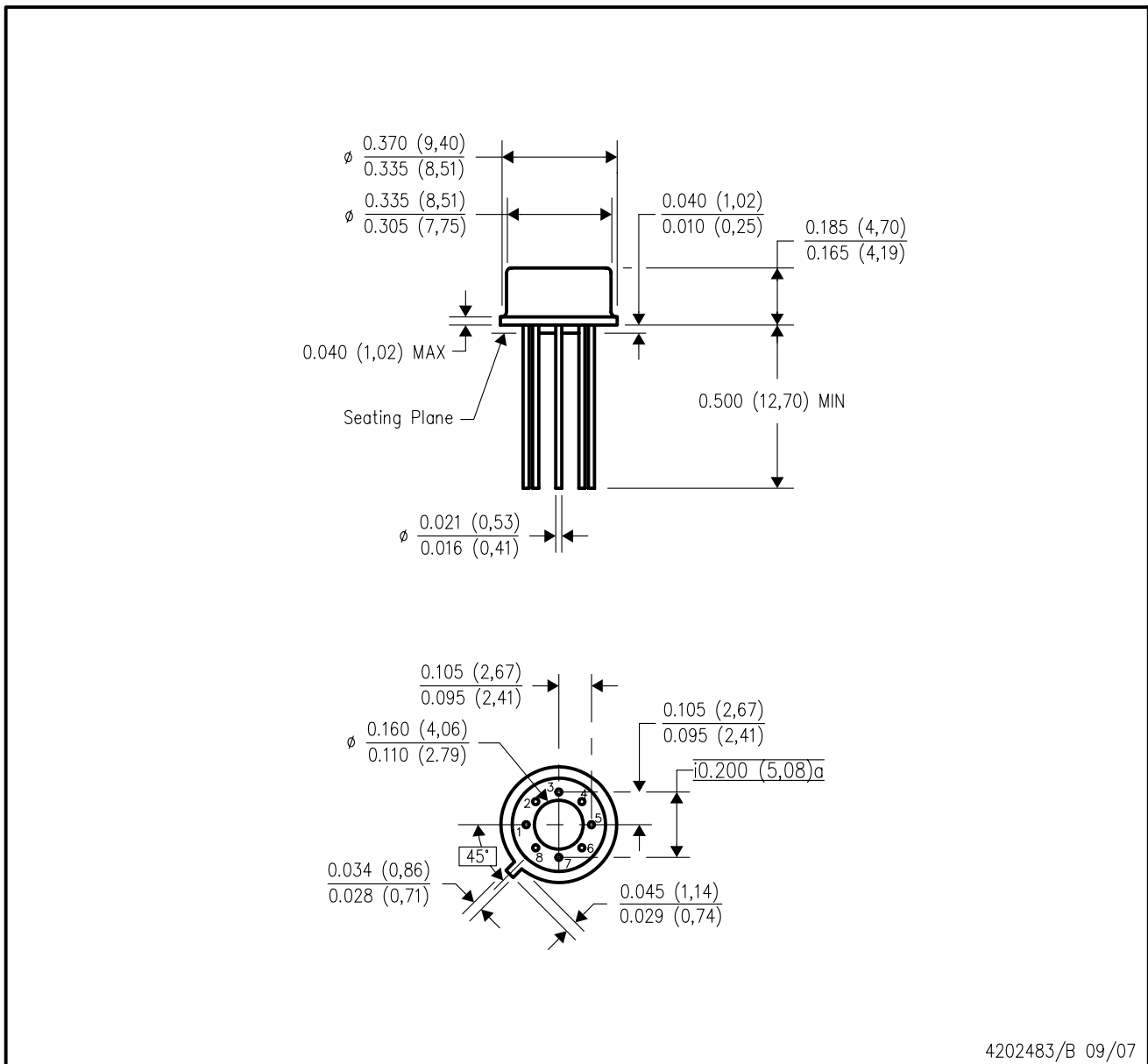

- NOTES:
- A. All linear dimensions are in inches (millimeters).
 - B. This drawing is subject to change without notice.
 - C. Leads in true position within 0.010 (0,25) R @ MMC at seating plane.
 - D. Pin numbers shown for reference only. Numbers may not be marked on package.
 - E. Falls within JEDEC MO-002/TO-99.

P (R-PDIP-T8)

PLASTIC DUAL-IN-LINE PACKAGE

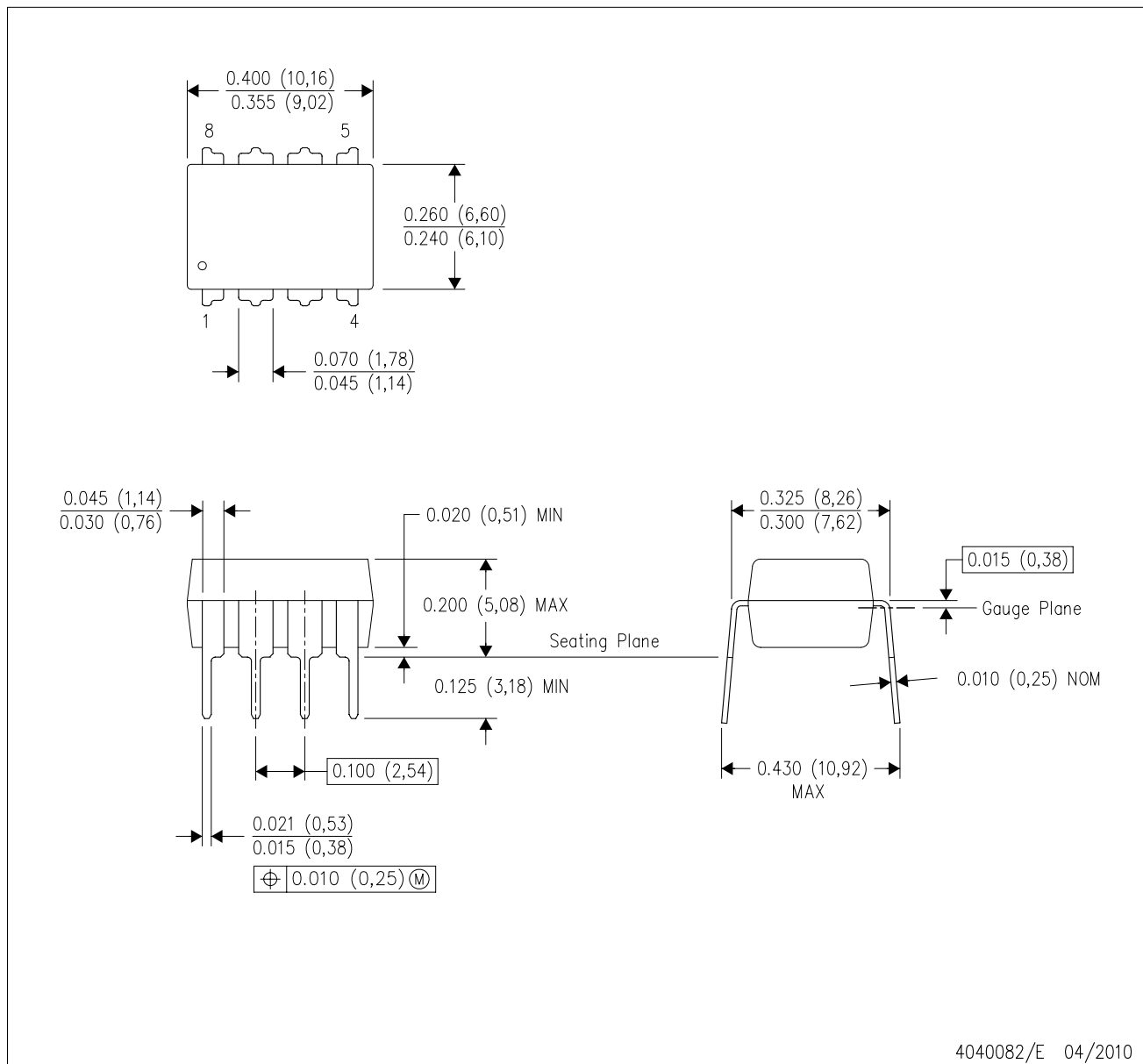

4040082/E 04/2010

- NOTES:
- A. All linear dimensions are in inches (millimeters).
 - B. This drawing is subject to change without notice.
 - C. Falls within JEDEC MS-001 variation BA.

NPA0014B

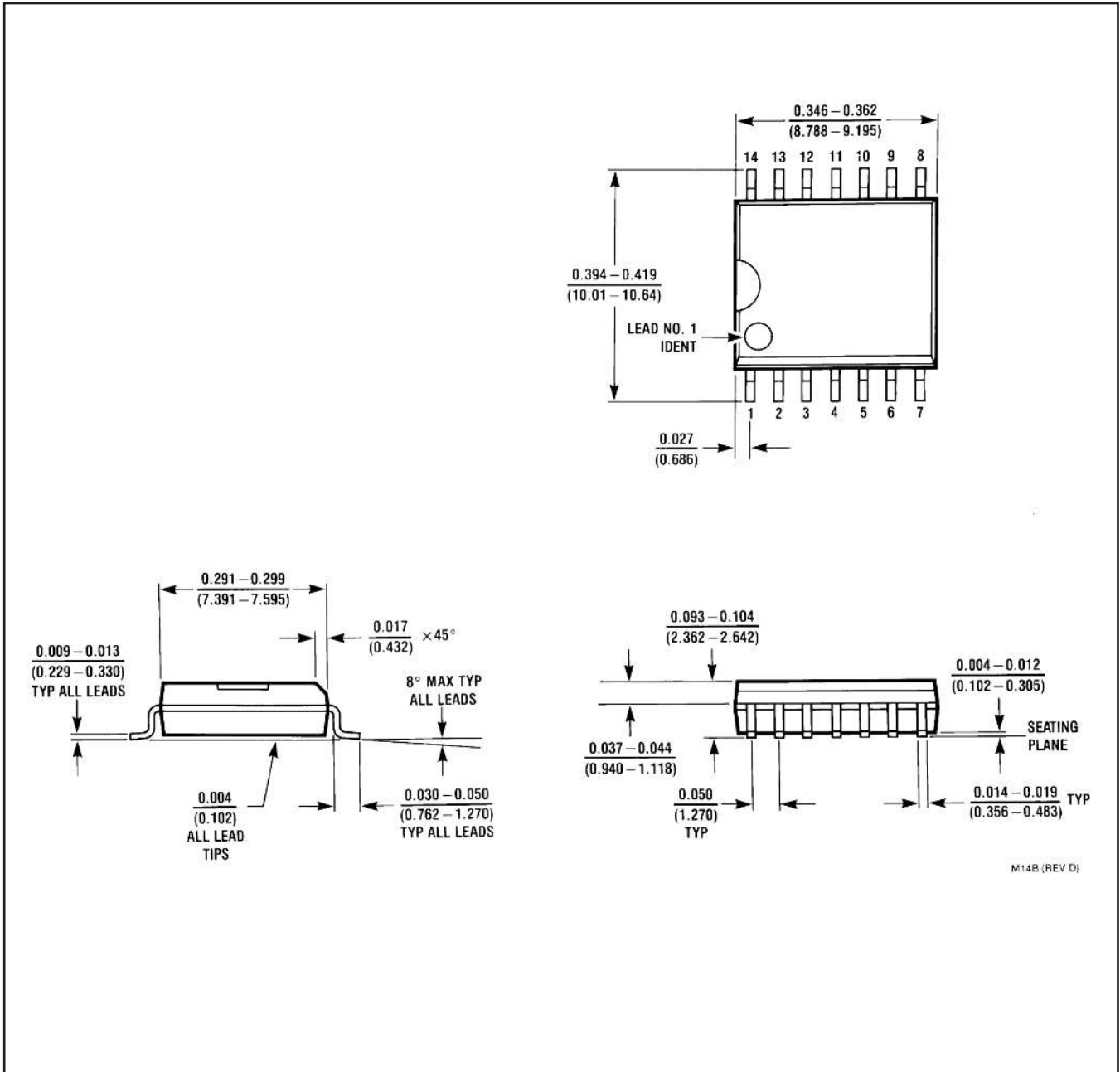

IMPORTANT NOTICE

Texas Instruments Incorporated and its subsidiaries (TI) reserve the right to make corrections, enhancements, improvements and other changes to its semiconductor products and services per JESD46, latest issue, and to discontinue any product or service per JESD48, latest issue. Buyers should obtain the latest relevant information before placing orders and should verify that such information is current and complete. All semiconductor products (also referred to herein as "components") are sold subject to TI's terms and conditions of sale supplied at the time of order acknowledgment.

TI warrants performance of its components to the specifications applicable at the time of sale, in accordance with the warranty in TI's terms and conditions of sale of semiconductor products. Testing and other quality control techniques are used to the extent TI deems necessary to support this warranty. Except where mandated by applicable law, testing of all parameters of each component is not necessarily performed.

TI assumes no liability for applications assistance or the design of Buyers' products. Buyers are responsible for their products and applications using TI components. To minimize the risks associated with Buyers' products and applications, Buyers should provide adequate design and operating safeguards.

TI does not warrant or represent that any license, either express or implied, is granted under any patent right, copyright, mask work right, or other intellectual property right relating to any combination, machine, or process in which TI components or services are used. Information published by TI regarding third-party products or services does not constitute a license to use such products or services or a warranty or endorsement thereof. Use of such information may require a license from a third party under the patents or other intellectual property of the third party, or a license from TI under the patents or other intellectual property of TI.

Reproduction of significant portions of TI information in TI data books or data sheets is permissible only if reproduction is without alteration and is accompanied by all associated warranties, conditions, limitations, and notices. TI is not responsible or liable for such altered documentation. Information of third parties may be subject to additional restrictions.

Resale of TI components or services with statements different from or beyond the parameters stated by TI for that component or service voids all express and any implied warranties for the associated TI component or service and is an unfair and deceptive business practice. TI is not responsible or liable for any such statements.

Buyer acknowledges and agrees that it is solely responsible for compliance with all legal, regulatory and safety-related requirements concerning its products, and any use of TI components in its applications, notwithstanding any applications-related information or support that may be provided by TI. Buyer represents and agrees that it has all the necessary expertise to create and implement safeguards which anticipate dangerous consequences of failures, monitor failures and their consequences, lessen the likelihood of failures that might cause harm and take appropriate remedial actions. Buyer will fully indemnify TI and its representatives against any damages arising out of the use of any TI components in safety-critical applications.

In some cases, TI components may be promoted specifically to facilitate safety-related applications. With such components, TI's goal is to help enable customers to design and create their own end-product solutions that meet applicable functional safety standards and requirements. Nonetheless, such components are subject to these terms.

No TI components are authorized for use in FDA Class III (or similar life-critical medical equipment) unless authorized officers of the parties have executed a special agreement specifically governing such use.

Only those TI components which TI has specifically designated as military grade or "enhanced plastic" are designed and intended for use in military/aerospace applications or environments. Buyer acknowledges and agrees that any military or aerospace use of TI components which have **not** been so designated is solely at the Buyer's risk, and that Buyer is solely responsible for compliance with all legal and regulatory requirements in connection with such use.

TI has specifically designated certain components as meeting ISO/TS16949 requirements, mainly for automotive use. In any case of use of non-designated products, TI will not be responsible for any failure to meet ISO/TS16949.

Products

Audio	www.ti.com/audio
Amplifiers	amplifier.ti.com
Data Converters	dataconverter.ti.com
DLP® Products	www.dlp.com
DSP	dsp.ti.com
Clocks and Timers	www.ti.com/clocks
Interface	interface.ti.com
Logic	logic.ti.com
Power Mgmt	power.ti.com
Microcontrollers	microcontroller.ti.com
RFID	www.ti-rfid.com
OMAP Applications Processors	www.ti.com/omap
Wireless Connectivity	www.ti.com/wirelessconnectivity

Applications

Automotive and Transportation	www.ti.com/automotive
Communications and Telecom	www.ti.com/communications
Computers and Peripherals	www.ti.com/computers
Consumer Electronics	www.ti.com/consumer-apps
Energy and Lighting	www.ti.com/energy
Industrial	www.ti.com/industrial
Medical	www.ti.com/medical
Security	www.ti.com/security
Space, Avionics and Defense	www.ti.com/space-avionics-defense
Video and Imaging	www.ti.com/video

TI E2E Community

e2e.ti.com