

THIS COPY IS PROVIDED ON A RESTRICTED BASIS AND IS NOT TO BE USED IN ANY WAY DETRIMENTAL TO THE INTERESTS OF PANDUIT CORP.

PANDUIT PART#	WEIGHT
NKUSBAA**	.02 LB/EACH PC (9.17 g/EACH PC)
IAPNKUSBAAWH	



NOTES:

1. SEE CURRENT CATALOG FOR ADDITIONAL PART NUMBER SUFFIXES TO INDICATE COLOR AND OR PACKAGE QUANTITY.
2. SEE CATALOG FOR COMPLETE LIST OF PARTS APPLICABLE FOR USE WITH THIS PART.
3. DIMENSIONS IN [] ARE METRIC.

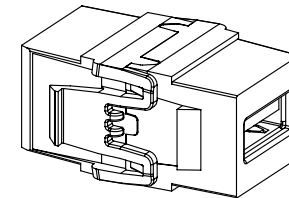
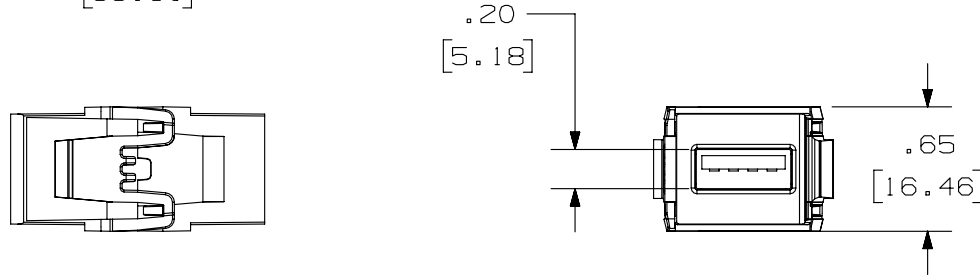
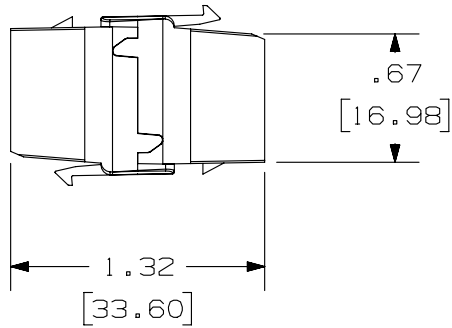

PART NUMBER		SEE TABLE	
TITLE			
NETKEY USB 2.0 FEMALE A TO FEMALE A COUPLER MODULE			
CUSTOMER DRAWING			
ITEM REVISION NAME		M03197AA/00	
DATASET FILE NAME		M03197AA_DC14/00C	
UNLESS OTHERWISE SPECIFIED, DIMENSIONAL TOLERANCES ARE: IN [mm]		MATERIAL:	
.x ± .xxx ± .010 [.3]		DRAWING NUMBER:	
.xx ± .03 [.8]		03197-14	
ANGLES ±		THIRD ANGLE PROJECTION	
DRAWN BY		CHK	
MDJR		HMK	
DATE		SCALE	
8-18-09		FULL	
DESCRIPTION		SHT 1 OF 1	
ECN		SIZE	
		A	

REV	DATE	BY	CHK	APR	DESCRIPTION	ECN
2	5-21-14	MDJR	REFR	JCK	B. UPDATED TITLE BLOCK.	03197-14
1	6-6-11	BJN	JCO	JCO	A. ADDED SUPPLEMENTAL P/N IAPNKUSBAAWH.	03197-14
R	9-17-09	MDJR	HMK	HMK	RELEASED TO PRODUCTION	03197-14

D10100DA/14