

1

2

3

4

5

6

7

A

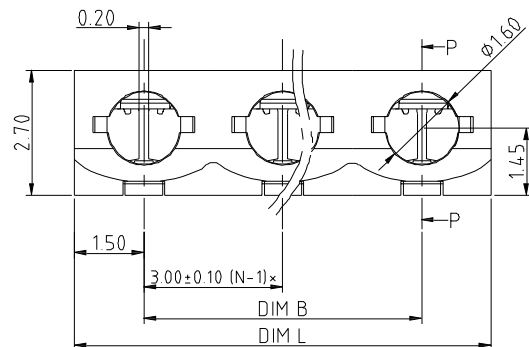

A

B

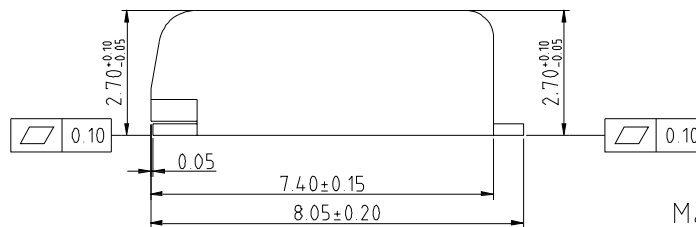

B

C

Material

- Item ①: Spring: PHBZ, Matte Tin plated over Nickel plated
- ② ● Item ②: Body: LCP (UL94V-0) Natural color
- Electrical UL(1977)
- Voltage rating: 150V
- Current rating: 3A
- Wire range:
- Solid wire(AWG): 22-26
- Wire strip length: 5-6mm
- Withstanding Voltage: 1.3KV
- Operating temperature: -40°C to +130°C
- Reflow Soldering temperature: 260°C/10 Sec max
- Safety Approval:
- Packing: tape reel

C

D

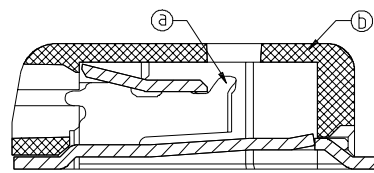

SECTION P-P

D

E

N=Number of poles

Dim.L	$(N-1) \times 3.0 + 3.0$
Dim.B	$(N-1) \times 3.0$

E

F

POLES	DIM B	DIM L
1P	/	+/-0.10
2P	+/-0.10	+/-0.15
3P	+/-0.20	+/-0.20

F

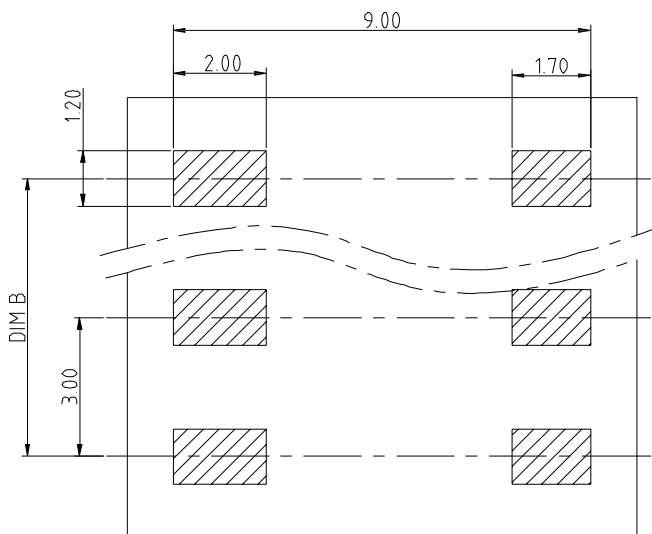

P.C.B. LAYOUT

TOLERANCE

RoHS compliant

Unit: mm



File No.: E198287

Scale	Free					Date	Name	Customer-No.
TOLERANCE						Drawn	13.12.2016	Winnie
X.	±0.50					Approved	11.04.2018	Winnie
X.X	±0.30							ASSMANN WSW-No.
X.XX	±0.10	②	Add the color of insulator	11.04.2018	Winnie			AWBR-300-xx-SR2
DIM	TOL	①	Add the UL File No.	25.07.2017	Winnie			Drawing-No.
		③	Drawn	13.12.2016	Winnie			ASS 7431 CO
X.°	±1°							Replace
Angle	TOL	Id.	Modification	Date	Name			Sheet

G

H

H

1

2

3

4

5

6

7