

NHD-C12864WC-FSW-FBW-3V3

COG (Chip-On-Glass) Liquid Crystal Display Module

NHD-	Newhaven Display
C12864-	128 x 64 Pixels
WM-	Model
F-	Transflective
SW-	Side White LED Backlight
F-	FSTN (+)
B-	6:00 Optimal View
W-	Wide Temp.
3V3-	3.0V LCD, 3.0V Backlight
	RoHS Compliant

Newhaven Display International, Inc.

2661 Galvin Court

Elgin IL, 60124

Ph: 847-844-8795

Fax: 847-844-8796

www.newhavendisplay.com

nhtech@newhavendisplay.com

nhsales@newhavendisplay.com

Document Revision History

Revision	Date	Description	Changed by
0	10/12/10	Initial Release	MC
1	5/25/10	Electrical characteristics updated	AK
2	4/4/13	Backlight mating connector part number updated	AK
3	3/16/15	Pin Description updated	RM
4	9/30/15	Wiring Diagram Updated, backlight max current rating added	SB
5	9/13/16	Capacitor Values Adjusted	SB
6	2/28/18	Mechanical, Electrical & Optical Characteristics Updated	SB
7	3/27/18	Backlight Characteristics Updated	SB
8	6/19/19	Backlight Voltage Updated	SB
9	5/3/21	Backlight Lifetime Updated	ZP
10	7/1/21	Updated Mechanical Drawing	JT

Functions and Features

- 128 x 64 pixels
- Built-in ST7565R controller
- Parallel/Serial interface
- 1/64 duty cycle; 1/9 bias
- RoHS Compliant

Mechanical Drawing

SYMBOL	REVISION	DATE

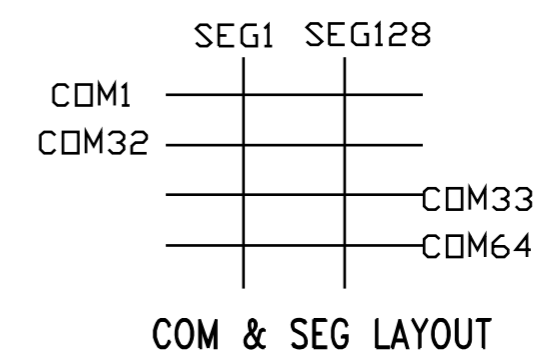
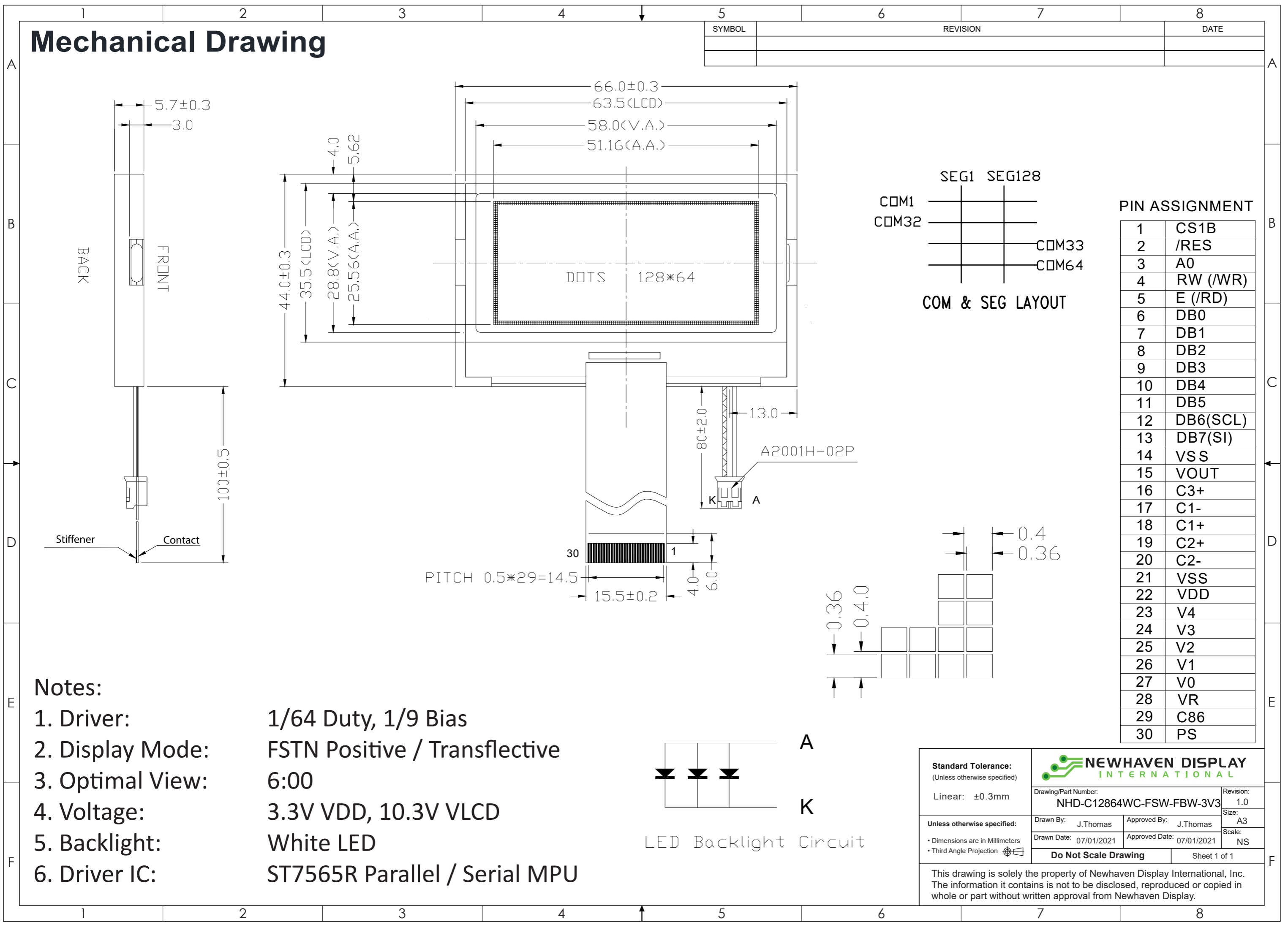

PIN ASSIGNMENT

1	CS1B
2	/RES
3	A0
4	RW (/WR)
5	E (/RD)
6	DB0
7	DB1
8	DB2
9	DB3
10	DB4
11	DB5
12	DB6(SCL)
13	DB7(SI)
14	VSS
15	VOUT
16	C3+
17	C1-
18	C1+
19	C2+
20	C2-
21	VSS
22	VDD
23	V4
24	V3
25	V2
26	V1
27	V0
28	VR
29	C86
30	PS

- Notes:**
1. Driver: 1/64 Duty, 1/9 Bias
 2. Display Mode: FSTN Positive / Transflective
 3. Optimal View: 6:00
 4. Voltage: 3.3V VDD, 10.3V VLCD
 5. Backlight: White LED
 6. Driver IC: ST7565R Parallel / Serial MPU

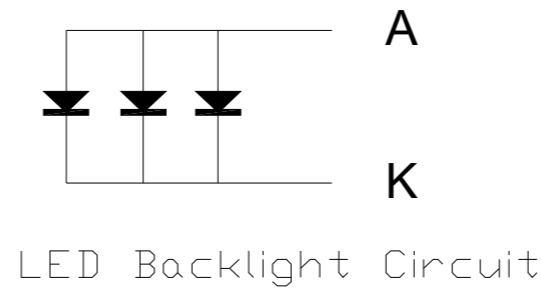

Standard Tolerance: (Unless otherwise specified) Linear: ±0.3mm			
	Drawing/Part Number: NHD-C12864WC-FSW-FBW-3V3	Revision: 1.0	
Unless otherwise specified: • Dimensions are in Millimeters • Third Angle Projection	Drawn By: J.Thomas	Approved By: J.Thomas	Size: A3
	Drawn Date: 07/01/2021	Approved Date: 07/01/2021	Scale: NS
Do Not Scale Drawing		Sheet 1 of 1	
This drawing is solely the property of Newhaven Display International, Inc. The information it contains is not to be disclosed, reproduced or copied in whole or part without written approval from Newhaven Display.			

Pin Description and Wiring Diagram

Pin No.	Symbol	External Connection	Function Description
1	CS1B	MPU	Active LOW Chip Select
2	/RES	MPU	Active LOW Reset signal
3	A0	MPU	Register Select signal. A0=0: Command, A0=1: Data
4	R/W /WR	MPU	6800 Mode: Read/Write select signal. R/W=1: Read R/W=0: Write 8080 Mode: Active LOW Write Signal
5	E /RD	MPU	6800 Mode: Active HIGH Enable Signal 8080 Mode: Active LOW Read Signal
6	DB0	MPU	Parallel Interface DB0-DB7: Bi-directional 8-bit data bus Serial Interface: DB0-DB5: No connect in serial mode DB6 = Serial clock DB7 = Serial data
7	DB1	MPU	
8	DB2	MPU	
9	DB3	MPU	
10	DB4	MPU	
11	DB5	MPU	
12	DB6(SCL)	MPU	
13	DB7(SI)	MPU	
14	V _{SS}	Power Supply	Ground (reference for voltage step-up circuit)
15	V _{OUT}	Power Supply	Connect capacitor to V _{SS} (PIN-14) (1.0-2.2μF)
16	CAP3+	Power Supply	Connect capacitor to CAP1- (PIN-17) (1.0-2.2μF)
17	CAP1-	Power Supply	Connect capacitor to CAP3+(PIN16) and CAP1+(PIN18) (1.0-2.2μF)
18	CAP1+	Power Supply	Connect capacitor to CAP1- (PIN-17) (1.0-2.2μF)
19	CAP2+	Power Supply	Connect capacitor to CAP2- (PIN-20) (1.0-2.2μF)
20	CAP2-	Power Supply	Connect capacitor to CAP2+ (PIN-19) (1.0-2.2μF)
21	V _{SS}	Power Supply	Ground
22	V _{DD}	Power Supply	Supply voltage for LCD and logic (3.0V)
23~27	V ₄ ~V ₀	Power Supply	0.1 – 1.0 μF capacitor to V _{DD} or V _{SS}
28	V _R	-	No Connect
29	C86	MPU	Select MPU interface pin. C86=H: 6800; C86=L: 8080
30	PS	MPU	Parallel/Serial Select. PS= H: Parallel; PS=L: Serial
A	LED+	Power Supply	Backlight Anode (+3.0V)
K	LED-	Power Supply	Backlight Cathode (Ground)

Recommended LCD connector: 0.5mm Pitch, 30 pin FFC. Molex p/n: 52892-3095

Backlight connector: A2001H-2P **Mates with:** A2001WR-2P, A2001WR-S-2P, A2001WV-2P, A2001WV-S-2P

Wiring Diagram

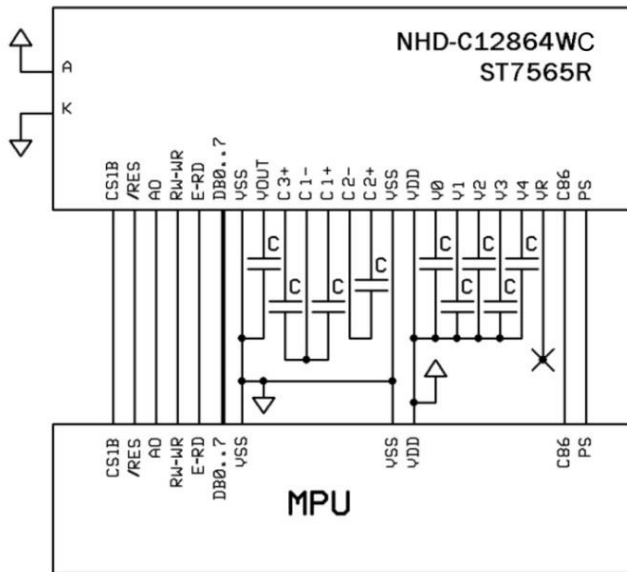

Electrical Characteristics

Item	Symbol	Condition	Min.	Typ.	Max.	Unit
Operating Temperature Range	T_{OP}	Absolute Max	-20	-	+70	$^{\circ}C$
Storage Temperature Range	T_{ST}	Absolute Max	-30	-	+80	$^{\circ}C$
Supply Voltage	V_{DD}	-	3.0	3.3	3.6	V
Supply Current	I_{DD}	$V_{DD} = 3.3V$	0.1	0.3	1.2	mA
Supply for LCD (contrast)	V_{LCD}	$T_{OP} = 25^{\circ}C$	10.0	10.3	10.6	V
"H" Level input	V_{IH}	-	$0.8 * V_{DD}$	-	V_{DD}	V
"L" Level input	V_{IL}	-	V_{SS}	-	$0.2 * V_{DD}$	V
"H" Level output	V_{OH}	-	$0.8 * V_{DD}$	-	V_{DD}	V
"L" Level output	V_{OL}	-	V_{SS}	-	$0.2 * V_{DD}$	V
Backlight Supply Voltage	V_{LED}	-	2.8	3.0	3.2	V
Backlight Supply Current	I_{LED}	$V_{LED} = 3.0V$	21	36	55	mA
Backlight Lifetime		$T_{OP} = 25^{\circ}C$	20,000		-	Hrs.

Optical Characteristics

Item	Symbol	Condition	Min.	Typ.	Max.	Unit
Optimal Viewing Angles	Top	$\varphi Y+$	-	20	-	$^{\circ}$
	Bottom	$\varphi Y-$	-	40	-	$^{\circ}$
	Left	$\theta X-$	-	45	-	$^{\circ}$
	Right	$\theta X+$	-	45	-	$^{\circ}$
Contrast Ratio	CR	-	3	5	-	-
Response Time	Rise	T_R	-	150	300	ms
	Fall	T_F	-	100	200	ms

Controller Information

Built-in ST7565R controller.

Please download specification at http://www.newhavendisplay.com/app_notes/ST7565R.pdf

Table of Commands

Command	Command Code									Function			
	A0	/RD	/WR	D7	D6	D5	D4	D3	D2		D1	D0	
(1) Display ON/OFF	0	1	0	1	0	1	0	1	1	1	0	1	LCD display ON/OFF 0: OFF, 1: ON
(2) Display start line set	0	1	0	0	1	Display start address					0	Sets the display RAM display start line address	
(3) Page address set	0	1	0	1	0	1	1	Page address			0	Sets the display RAM page address	
(4) Column address set upper bit	0	1	0	0	0	0	1	Most significant column address			0	Sets the most significant 4 bits of the display RAM column address.	
Column address set lower bit				0	0	0	0	Least significant column address			0	Sets the least significant 4 bits of the display RAM column address.	
(5) Status read	0	0	1	Status			0	0	0	0	0	Reads the status data	
(6) Display data write	1	1	0	Write data								Writes to the display RAM	
(7) Display data read	1	0	1	Read data								Reads from the display RAM	
(8) ADC select	0	1	0	1	0	1	0	0	0	0	0	1	Sets the display RAM address SEG output correspondence 0: normal, 1: reverse
(9) Display normal/reverse	0	1	0	1	0	1	0	0	1	1	0	1	Sets the LCD display normal/ reverse 0: normal, 1: reverse
(10) Display all points ON/OFF	0	1	0	1	0	1	0	0	1	0	0	1	Display all points 0: normal display 1: all points ON
(11) LCD bias set	0	1	0	1	0	1	0	0	0	1	0	1	Sets the LCD drive voltage bias ratio 0: 1/9 bias, 1: 1/7 bias (ST7565R)
(12) Read-modify-write	0	1	0	1	1	1	0	0	0	0	0	0	Column address increment At write: +1 At read: 0
(13) End	0	1	0	1	1	1	0	1	1	1	0	0	Clear read/modify/write
(14) Reset	0	1	0	1	1	1	0	0	0	0	1	0	Internal reset
(15) Common output mode select	0	1	0	1	1	0	0	0	*	*	*	1	Select COM output scan direction 0: normal direction 1: reverse direction
(16) Power control set	0	1	0	0	0	1	0	1	Operating mode			0	Select internal power supply operating mode
(17) V ₀ voltage regulator internal resistor ratio set	0	1	0	0	0	1	0	0	Resistor ratio			0	Select internal resistor ratio(Rb/Ra) mode
(18) Electronic volume mode set	0	1	0	1	0	0	0	0	0	0	0	1	Set the V ₀ output voltage electronic volume register
Electronic volume register set				0	0	Electronic volume value					0		
(19) Sleep mode set	0	1	0	1	0	1	0	1	1	0	0	1	0: Sleep mode, 1: Normal mode
(20) Booster ratio set	0	1	0	1	1	1	1	1	0	0	0	0	select booster ratio 00: 2x,3x,4x 01: 5x 11: 6x
				0	0	0	0	0	0	0	step-up value		
(21) NOP	0	1	0	1	1	1	0	0	0	0	1	1	Command for non-operation
(22) Test	0	1	0	1	1	1	1	*	*	*	*	*	Command for IC test. Do not use this command

Timing Characteristics

System Bus Read/Write Characteristics 1 (For the 8080 Series MPU)

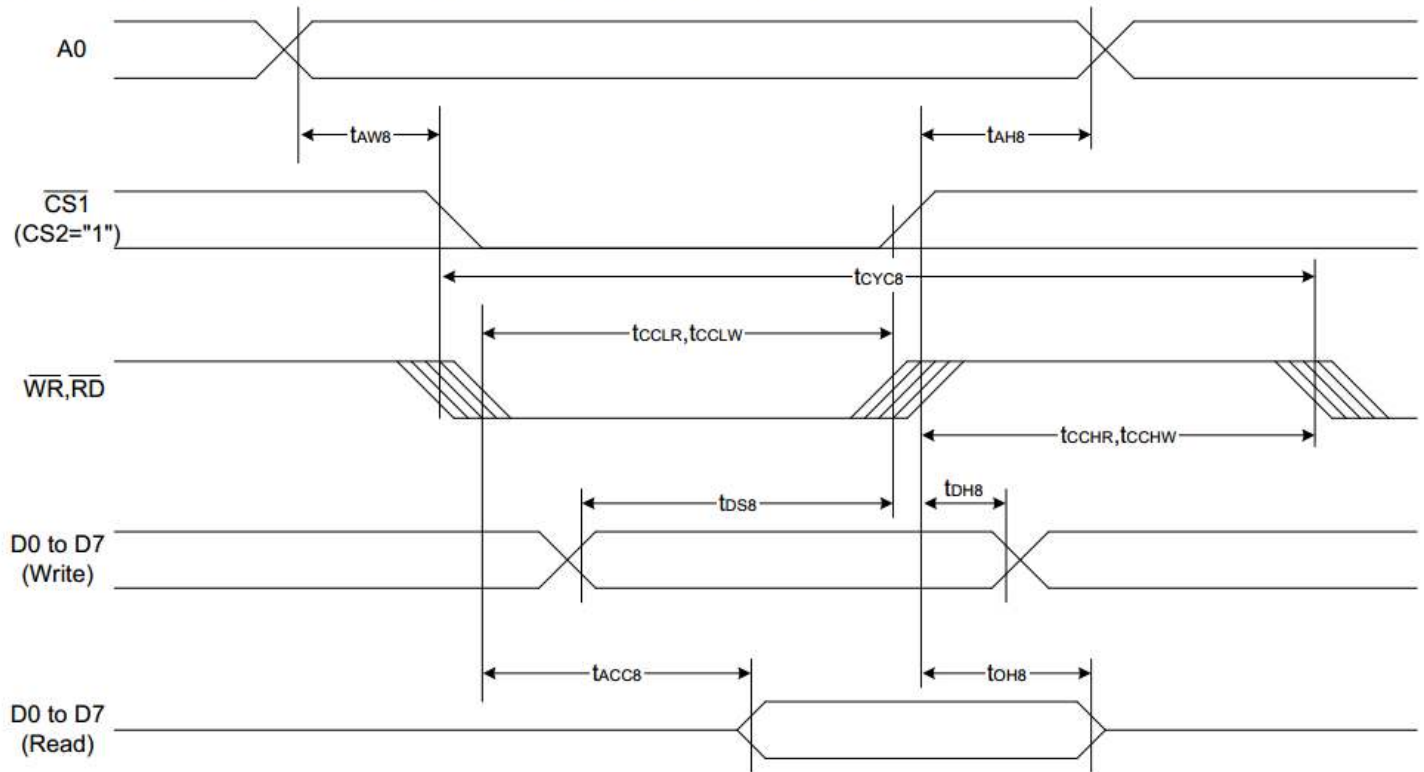

($V_{DD} = 3.3V$, $T_a = -30$ to $85^\circ C$)

Item	Signal	Symbol	Condition	Rating		Units
				Min.	Max.	
Address hold time	A0	tAH8		0	—	Ns
Address setup time		tAW8		0	—	
System cycle time		tCYC8		240	—	
Enable L pulse width (WRITE)	WR	tCCLW		80	—	
Enable H pulse width (WRITE)		tCCHW		80	—	
Enable L pulse width (READ)	RD	tCCLR		140	—	
Enable H pulse width (READ)		tCCHR		80	—	
WRITE Data setup time	D0 to D7	tDS8		40	—	
WRITE Address hold time		tDH8		0	—	
READ access time		tACC8	CL = 100 pF	—	70	
READ Output disable time		tOH8	CL = 100 pF	5	50	

System Bus Read/Write Characteristics 2 (For the 6800 Series MPU)

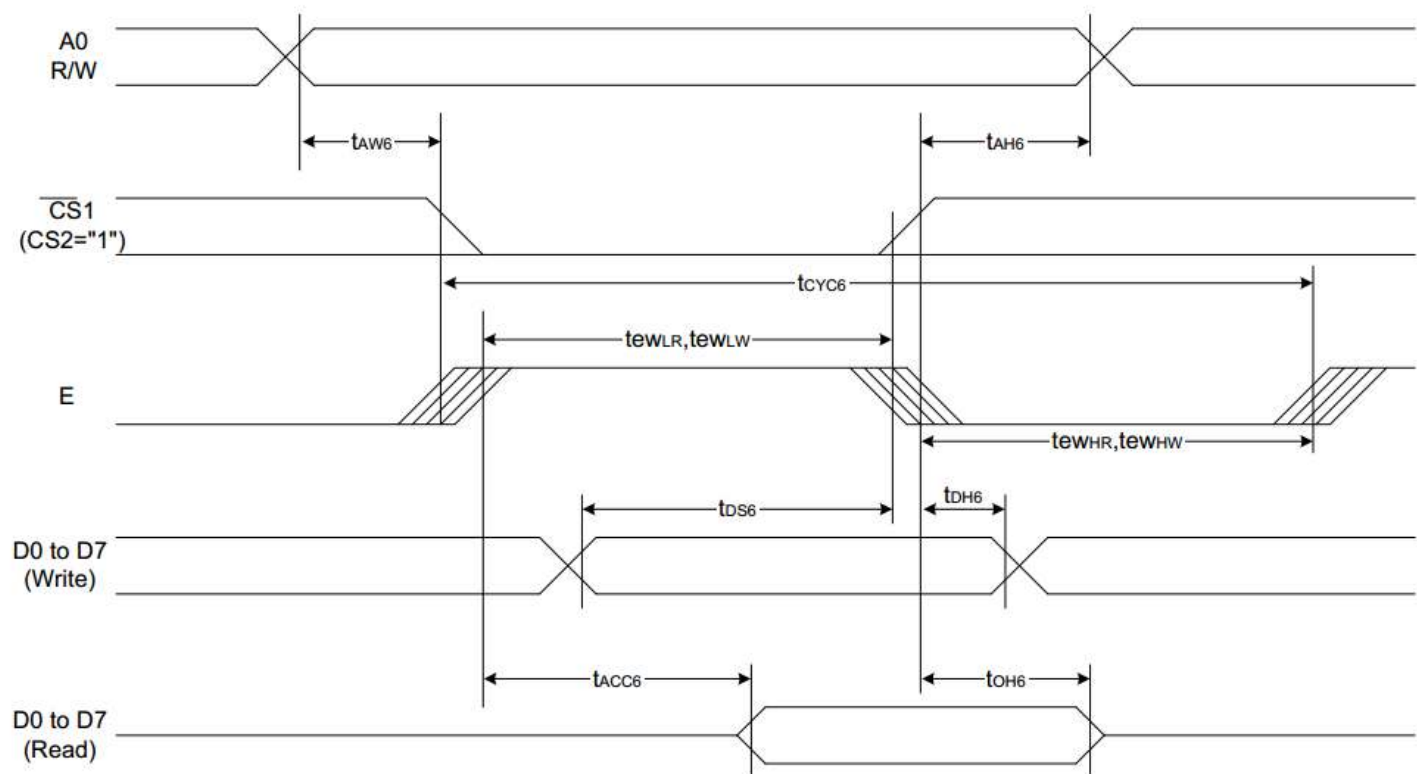

($V_{DD} = 3.3V, T_a = -30 \text{ to } 85^\circ\text{C}$)

Item	Signal	Symbol	Condition	Rating		Units
				Min.	Max.	
Address hold time	A0	t_{AH6}		0	—	ns
Address setup time		t_{AW6}		0	—	
System cycle time		t_{CYC6}		240	—	
Enable L pulse width (WRITE)	WR	t_{EWLW}		80	—	
Enable H pulse width (WRITE)		t_{EWHW}		80	—	
Enable L pulse width (READ)	RD	t_{EWLR}		80	—	
Enable H pulse width (READ)		t_{EWHR}		140	—	
WRITE Data setup time	D0 to D7	t_{DS6}		40	—	
WRITE Address hold time		t_{DH6}		0	—	
READ access time		t_{ACC6}	$C_L = 100 \text{ pF}$	—	70	
READ Output disable time		t_{OH6}	$C_L = 100 \text{ pF}$	5	50	

The 4-line SPI Interface

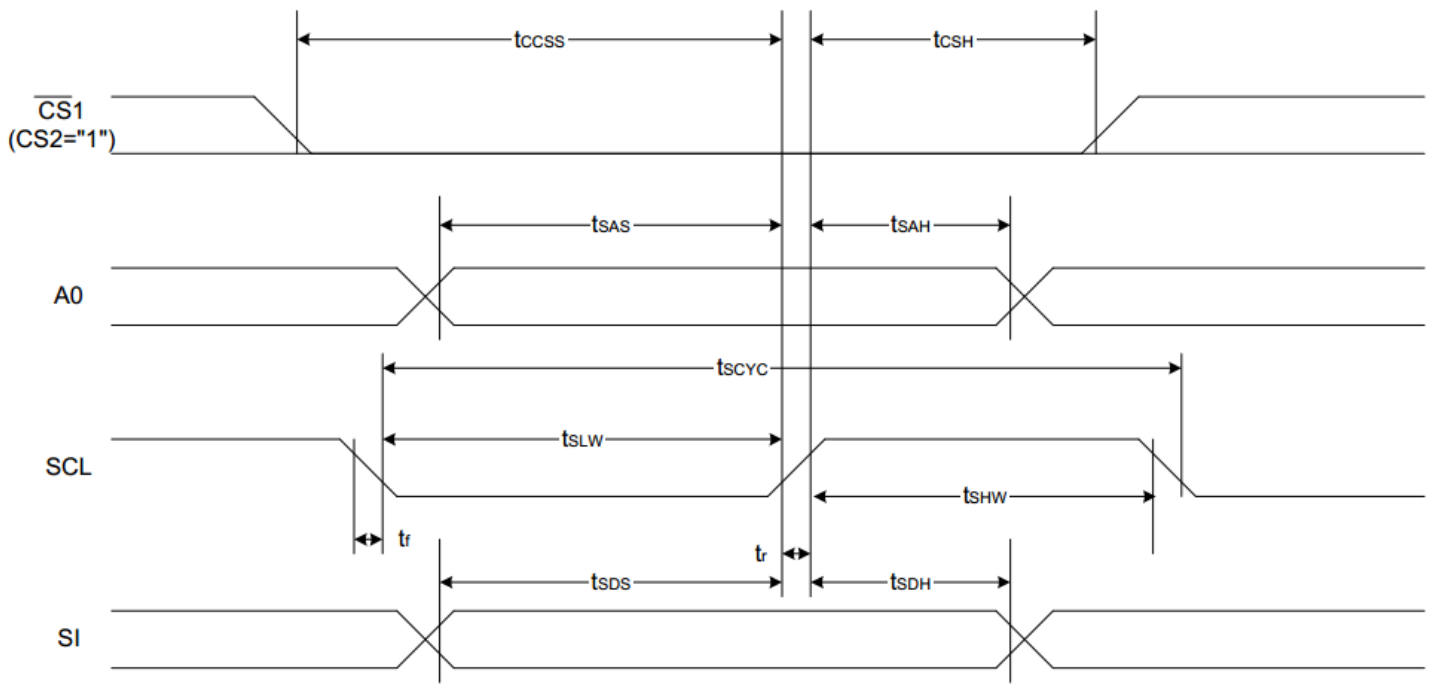

($V_{\text{DD}} = 3.3\text{V}$, $T_a = -30$ to 85°C)

Item	Signal	Symbol	Condition	Rating		Units
				Min.	Max.	
4-line SPI Clock Period	SCL	T_{scyc}		50	—	ns
SCL "H" pulse width		T_{shw}		25	—	
SCL "L" pulse width		T_{SLW}		25	—	
Address setup time	A0	T_{SAS}		20	—	
Address hold time		T_{SAH}		10	—	
Data setup time	SI	T_{sds}		20	—	
Data hold time		T_{SDH}		10	—	
CS-SCL time	CS	T_{CSS}		20	—	
CS-SCL time		T_{CSH}		40	—	

Example Initialization Program

```
'-----  
Sub Init  
Reset P3.7          'set Read/write to '0' for write  
Reset P3.0          'RS  
Set P3.1            'reset  
Reset P3.4 'E  
'Set P3.3  
'Reset P3.3  
Waitms 2  
'Set P3.3  
Waitms 20  
A = &HA2            '1/9 BIAS  
Call Writecom  
A = &HA0            'ADC SELECT , NORMAL  
Call Writecom  
A = &HC8            'COM OUTPUT REVERSE  
Call Writecom  
A = &HA4            'DISPLAY ALL POINTS NORMAL  
Call Writecom  
A = &H40            'DISPLAY START LINE SET  
Call Writecom  
A = &H25            'INTERNAL RESISTOR RATIO  
Call Writecom  
A = &H81            'ELECTRONIC VOLUME MODE SET  
Call Writecom  
A = &H10            'ELECTRONIC VOLUME  
Call Writecom  
A = &H2F            'POWER CONTROLLER SET  
Call Writecom  
A = &HAF            'DISPLAY ON  
Call Writecom  
End Sub
```

```
'-----  
Sub Writecom  
Reset P3.0          'A0 low  
Reset P3.7          'R/W low  
Set P3.6            'CS2  
Set P3.4            'E  
P1 = A  
Reset P3.4  
Reset P3.6  
Reset P3.7  
End Sub
```

```
Sub Writedata  
Set P3.0            'A0 high  
Reset P3.7          'R/W low  
Set P3.6            'CS2  
Set P3.4            'E  
P1 = A  
Reset P3.4  
Reset P3.6  
Reset P3.7  
End Sub  
'-----
```

Quality Information

Test Item	Content of Test	Test Condition	Note
High Temperature storage	Endurance test applying the high storage temperature for a long time.	+80°C , 240hrs	2
Low Temperature storage	Endurance test applying the low storage temperature for a long time.	-30°C , 240hrs	1,2
High Temperature Operation	Endurance test applying the electric stress (voltage & current) and the high thermal stress for a long time.	+70°C 240hrs	2
Low Temperature Operation	Endurance test applying the electric stress (voltage & current) and the low thermal stress for a long time.	-20°C , 240hrs	1,2
High Temperature / Humidity Operation	Endurance test applying the electric stress (voltage & current) and the high thermal with high humidity stress for a long time.	+60°C , 90% RH , 96hrs	1,2
Thermal Shock resistance	Endurance test applying the electric stress (voltage & current) during a cycle of low and high thermal stress.	-20°C,30min -> 25°C,5min -> 70°C,30min = 1 cycle 10 cycles	
Vibration test	Endurance test applying vibration to simulate transportation and use.	10-55Hz , 15mm amplitude. 60 sec in each of 3 directions X,Y,Z For 15 minutes	3
Static electricity test	Endurance test applying electric static discharge.	VS=800V, RS=1.5kΩ, CS=100pF One time	

Note 1: No condensation to be observed.

Note 2: Conducted after 4 hours of storage at 25°C, 0%RH.

Note 3: Test performed on product itself, not inside a container.

Precautions for using LCDs/LCMs

See Precautions at www.newhavendisplay.com/specs/precautions.pdf

Warranty Information and Terms & Conditions

http://www.newhavendisplay.com/index.php?main_page=terms