

FEATURES:

- 0.5 MICRON CMOS Technology
- High-speed, low-power CMOS replacement for ABT functions
- Typical $t_{SK(o)}$ (Output Skew) < 250ps
- Low input and output leakage $\leq 1\mu A$ (max.)
- High drive outputs (-32mA IOH, 64mA IOL)
- Power off disable outputs permit "live insertion"
- Typical VOLP (Output Ground Bounce) < 1.0V at VCC = 5V, TA = 25°C
- Available in SSOP and TSSOP packages

DESCRIPTION:

The FCT16952T 16-bit registered transceiver is built using advanced dual metal CMOS technology. These high-speed, low-power devices are organized as two independent 8-bit D-type registered transceivers with separate input and output control for independent control of data flow in either direction. For example, the A-to-B Enable (\overline{xCEAB}) must be low to enter data from the A port. $xCLKAB$ controls the clocking function. When $xCLKAB$ toggles from low-to-high, the data present on the A port will be clocked into the register. \overline{xOEAB} performs the output enable function on the B port. Data flow from the B port to A port is similar but requires using \overline{xCEBA} , $xCLKBA$, and \overline{xOEBA} inputs. Full 16-bit operation is achieved by tying the control pins of the independent transceivers together.

The FCT16952T is ideally suited for driving high-capacitance loads and low-impedance backplanes. The output buffers are designed with power off disable capability allowing "live insertion" of boards when used as backplane drivers.

FUNCTIONAL BLOCK DIAGRAM

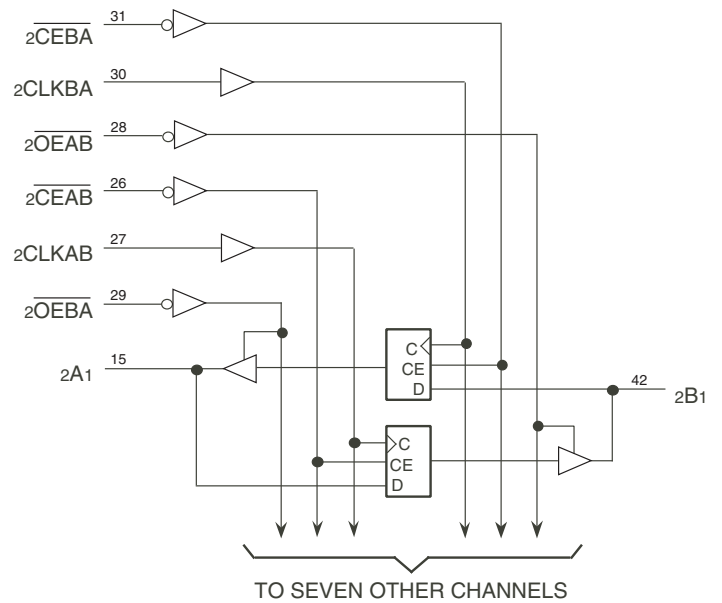
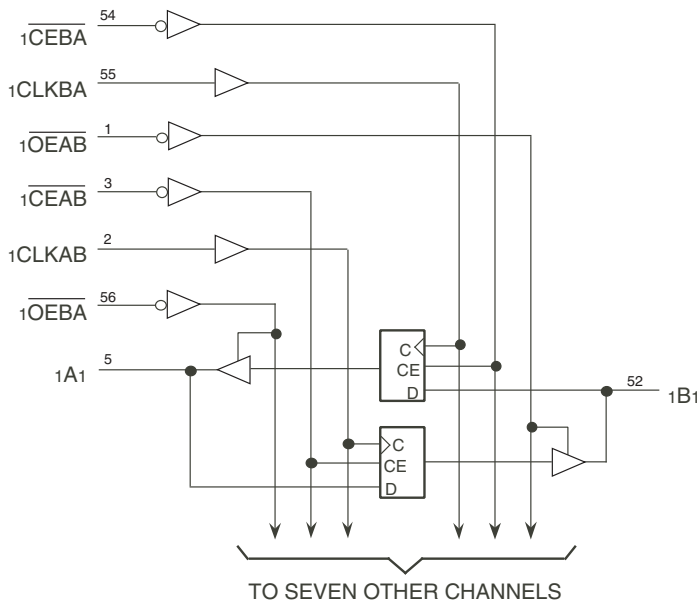

PIN CONFIGURATION

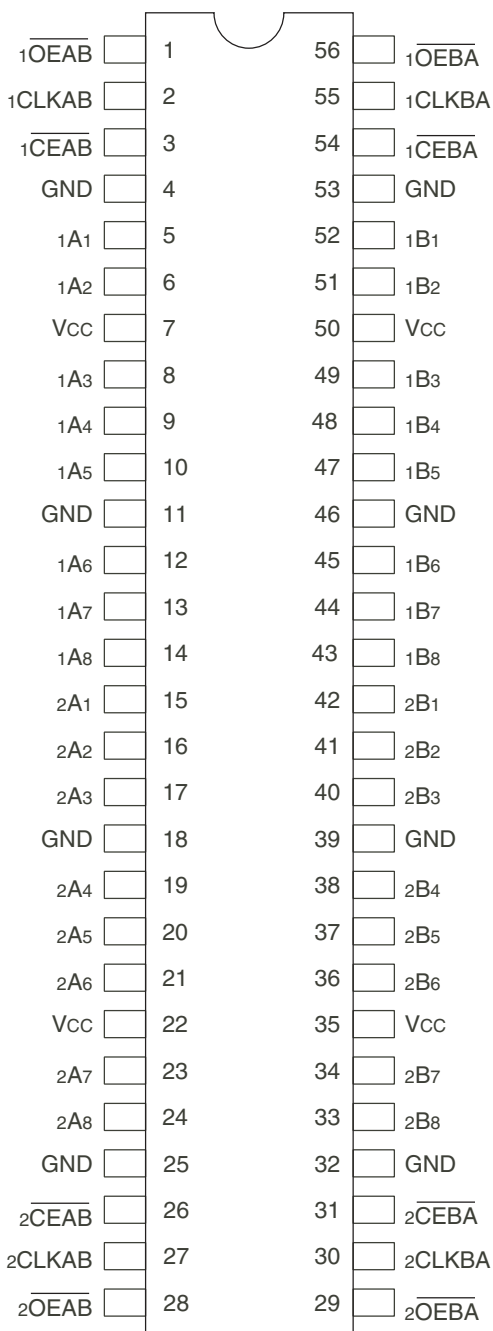

TOP VIEW

Package Type	Package Code	Order Code
TSSOP	PAG56	PAG
SSOP	PVG56	PVG

PIN DESCRIPTION

Pin Names	Description
\overline{xOEAB}	A-to-B Output Enable Input (Active LOW)
$\overline{xOEB\overline{A}}$	B-to-A Output Enable Input (Active LOW)
\overline{xCEAB}	A-to-B Clock Enable Input (Active LOW)
$\overline{xCEB\overline{A}}$	B-to-A Clock Enable Input (Active LOW)
$xCLKAB$	A-to-B Clock Input
$xCLKBA$	B-to-A Clock Input
xAx	A-to-B Data Inputs or B-to-A 3-State Outputs
xBx	B-to-A Data Inputs or A-to-B 3-State Outputs

ABSOLUTE MAXIMUM RATINGS⁽¹⁾

Symbol	Description	Max	Unit
$V_{TERM}^{(2)}$	Terminal Voltage with Respect to GND	-0.5 to +7	V
$V_{TERM}^{(3)}$	Terminal Voltage with Respect to GND	-0.5 to $V_{CC}+0.5$	V
TSTG	Storage Temperature	-65 to +150	°C
I _{OUT}	DC Output Current	-60 to +120	mA

NOTES:

- Stresses greater than those listed under ABSOLUTE MAXIMUM RATINGS may cause permanent damage to the device. This is a stress rating only and functional operation of the device at these or any other conditions above those indicated in the operational sections of this specification is not implied. Exposure to absolute maximum rating conditions for extended periods may affect reliability.
- All device terminals except FCT162XXX Output and I/O terminals.
- Output and I/O terminals for FCT162XXX.

CAPACITANCE ($T_A = +25^\circ\text{C}$, $F = 1.0\text{MHz}$)

Symbol	Parameter ⁽¹⁾	Conditions	Typ.	Max.	Unit
C _{IN}	Input Capacitance	$V_{IN} = 0V$	3.5	6	pF
C _{OUT}	Output Capacitance	$V_{OUT} = 0V$	3.5	8	pF

NOTE:

- This parameter is measured at characterization but not tested.

FUNCTION TABLE^(1,3)

Inputs				Outputs
\overline{xCEAB}	$xCLKAB$	$\overline{xOEB\overline{A}}$	xAx	xBx
H	X	L	X	$B^{(2)}$
X	L	L	X	$B^{(2)}$
L	↑	L	L	L
L	↑	L	H	H
X	X	H	X	Z

NOTES:

- A-to-B data flow is shown: B-to-A data flow is similar but uses $\overline{xCEB\overline{A}}$, $xCLKBA$, and $\overline{xOEA\overline{B}}$.
- Level of B before the indicated steady-state input conditions were established.
- H = HIGH Voltage Level
L = LOW Voltage Level
X = Don't Care
↑ = LOW-to-HIGH Transition
Z = High-impedance

DC ELECTRICAL CHARACTERISTICS OVER OPERATING RANGE

Following Conditions Apply Unless Otherwise Specified:

Industrial: $T_A = -40^\circ\text{C}$ to $+85^\circ\text{C}$, $V_{CC} = 5.0\text{V} \pm 10\%$

Symbol	Parameter	Test Conditions ⁽¹⁾		Min.	Typ. ⁽²⁾	Max.	Unit
V_{IH}	Input HIGH Level	Guaranteed Logic HIGH Level		2	—	—	V
V_{IL}	Input LOW Level	Guaranteed Logic LOW Level		—	—	0.8	V
I_{IH}	Input HIGH Current (Input pins) ⁽⁵⁾	$V_{CC} = \text{Max.}$	$V_I = V_{CC}$	—	—	± 1	μA
	Input HIGH Current (I/O pins) ⁽⁵⁾			—	—	± 1	
I_{IL}	Input LOW Current (Input pins) ⁽⁵⁾		$V_I = \text{GND}$	—	—	± 1	
	Input LOW Current (I/O pins) ⁽⁵⁾			—	—	± 1	
I_{OZH}	High Impedance Output Current (3-State Output pins) ⁽⁵⁾	$V_{CC} = \text{Max.}$	$V_O = 2.7\text{V}$	—	—	± 1	μA
I_{OZL}			$V_O = 0.5\text{V}$	—	—	± 1	
V_{IK}	Clamp Diode Voltage	$V_{CC} = \text{Min.}, I_{IN} = -18\text{mA}$		—	-0.7	-1.2	V
I_{OS}	Short Circuit Current	$V_{CC} = \text{Max.}, V_O = \text{GND}^{(3)}$		-80	-140	-250	mA
V_H	Input Hysteresis	—		—	100	—	mV
I_{CCL} I_{CCH} I_{CCZ}	Quiescent Power Supply Current	$V_{CC} = \text{Max.}$ $V_{IN} = \text{GND}$ or V_{CC}		—	5	500	μA

OUTPUT DRIVE CHARACTERISTICS

Symbol	Parameter	Test Conditions ⁽¹⁾		Min.	Typ. ⁽²⁾	Max.	Unit
I_O	Output Drive Current	$V_{CC} = \text{Max.}, V_O = 2.5\text{V}^{(3)}$		-50	—	-180	mA
V_{OH}	Output HIGH Voltage	$V_{CC} = \text{Min.}$ $V_{IN} = V_{IH}$ or V_{IL}	$I_{OH} = -3\text{mA}$	2.5	3.5	—	V
			$I_{OH} = -15\text{mA}$	2.4	3.5	—	
			$I_{OH} = -32\text{mA}^{(4)}$	2	3	—	
V_{OL}	Output LOW Voltage	$V_{CC} = \text{Min.}$ $V_{IN} = V_{IH}$ or V_{IL}	$I_{OL} = 64\text{mA}$	—	0.2	0.55	V
I_{OFF}	Input/Output Power Off Leakage ⁽⁵⁾	$V_{CC} = 0\text{V}, V_{IN}$ or $V_O \leq 4.5\text{V}$		—	—	± 1	μA

NOTES:

1. For conditions shown as Min. or Max., use appropriate value specified under Electrical Characteristics for the applicable device type.
2. Typical values are at $V_{CC} = 5.0\text{V}$, $+25^\circ\text{C}$ ambient.
3. Not more than one output should be shorted at one time. Duration of the test should not exceed one second.
4. Duration of the condition can not exceed one second.
5. The test limit for this parameter is $\pm 5\mu\text{A}$ at $T_A = -55^\circ\text{C}$.

POWER SUPPLY CHARACTERISTICS

Symbol	Parameter	Test Conditions ⁽¹⁾		Min.	Typ. ⁽²⁾	Max.	Unit
ΔI_{CC}	Quiescent Power Supply Current TTL Inputs HIGH	$V_{CC} = \text{Max.}$ $V_{IN} = 3.4V^{(3)}$		—	0.5	1.5	mA
I_{CCD}	Dynamic Power Supply Current ⁽⁴⁾	$V_{CC} = \text{Max.}$, Outputs Open $\overline{xOEAB} = \overline{xOEBA} = \text{GND}$ One Input Toggling 50% Duty Cycle	$V_{IN} = V_{CC}$ $V_{IN} = \text{GND}$	—	75	120	$\mu\text{A}/\text{MHz}$
I_C	Total Power Supply Current ⁽⁶⁾	$V_{CC} = \text{Max.}$, Outputs Open $f_{CP} = 10\text{MHz}$ (xCLKAB) 50% Duty Cycle $\overline{xOEAB} = \overline{xCEAB} = \text{GND}$ $\overline{xOEBA} = V_{CC}$ $f_i = 5\text{MHz}$ 50% Duty Cycle One Bit Toggling	$V_{IN} = V_{CC}$ $V_{IN} = \text{GND}$	—	0.8	1.7	mA
			$V_{IN} = 3.4V$ $V_{IN} = \text{GND}$	—	1.3	3.2	
		$V_{CC} = \text{Max.}$, Outputs Open $f_{CP} = 10\text{MHz}$ (xCLKAB) 50% Duty Cycle $\overline{xOEAB} = \overline{xCEAB} = \text{GND}$ $\overline{xOEBA} = V_{CC}$ $f_i = 2.5\text{MHz}$ 50% Duty Cycle Sixteen Bits Toggling	$V_{IN} = V_{CC}$ $V_{IN} = \text{GND}$	—	3.8	6.5 ⁽⁵⁾	
			$V_{IN} = 3.4V$ $V_{IN} = \text{GND}$	—	8.3	20 ⁽⁵⁾	

NOTES:

- For conditions shown as Min. or Max., use appropriate value specified under Electrical Characteristics for the applicable device type.
- Typical values are at $V_{CC} = 5.0V$, $+25^\circ\text{C}$ ambient.
- Per TTL driven input ($V_{IN} = 3.4V$). All other inputs at V_{CC} or GND.
- This parameter is not directly testable, but is derived for use in Total Power Supply Calculations.
- Values for these conditions are examples of the I_{CC} formula. These limits are guaranteed but not tested.
- $I_C = I_{QUIESCENT} + I_{INPUTS} + I_{DYNAMIC}$
 $I_C = I_{CC} + \Delta I_{CC} D_H N_T + I_{CCD} (f_{CP} N_{CP}/2 + f_i N_i)$
 $I_{CC} = \text{Quiescent Current (} I_{CCL}, I_{CCH} \text{ and } I_{CCZ})$
 $\Delta I_{CC} = \text{Power Supply Current for a TTL High Input (} V_{IN} = 3.4V)$
 $D_H = \text{Duty Cycle for TTL Inputs High}$
 $N_T = \text{Number of TTL Inputs at } D_H$
 $I_{CCD} = \text{Dynamic Current Caused by an Input Transition Pair (HLH or LHL)}$
 $f_{CP} = \text{Clock Frequency for Register Devices (Zero for Non-Register Devices)}$
 $N_{CP} = \text{Number of Clock Inputs at } f_{CP}$
 $f_i = \text{Input Frequency}$
 $N_i = \text{Number of Inputs at } f_i$

SWITCHING CHARACTERISTICS OVER OPERATING RANGE - INDUSTRIAL

Symbol	Parameter	Condition ⁽¹⁾	FCT16952AT		FCT16952CT		FCT16952ET		Unit
			Min. ⁽²⁾	Max.	Min. ⁽²⁾	Max.	Min. ⁽²⁾	Max.	
t _{PLH} t _{PHL}	Propagation Delay xCLKAB, xCLKBA to xBx, xAx	CL = 50pF RL = 500Ω	2	10	2	6.3	1.5	3.7	ns
t _{PZH} t _{PZL}	Output Enable Time x \overline{OEBA} , x \overline{OEAB} to xAx, xBx		1.5	10.5	1.5	7	1.5	4.4	ns
t _{PHZ} t _{PLZ}	Output Disable Time x \overline{OEBA} , x \overline{OEAB} to xAx, xBx		1.5	10	1.5	6.5	1.5	3.6	ns
t _{SU}	Set-up Time, HIGH or LOW xAx, xBx to xCLKAB, xCLKBA		2.5	—	2.5	—	1.5	—	ns
t _H	Hold Time, HIGH or LOW xAx, xBx to xCLKAB, xCLKBA		2	—	1.5	—	0	—	ns
t _{SU}	Set-up Time, HIGH or LOW x \overline{CEBA} , x \overline{CEAB} , to xCLKAB, xCLKBA		3	—	3	—	2	—	ns
t _H	Hold Time, HIGH or LOW x \overline{CEBA} , x \overline{CEAB} , to xCLKAB, xCLKBA		2	—	2	—	0	—	ns
t _w	Pulse Width HIGH or LOW, xCLKAB or xCLKBA ⁽³⁾		3	—	3	—	3	—	ns
t _{sk(o)}	Output Skew ⁽⁴⁾		—	0.5	—	0.5	—	0.5	ns

NOTES:

1. See test circuit and waveforms.
2. Minimum limits are guaranteed but not tested.
3. This limit is guaranteed but not tested.
4. Skew between any two outputs, of the same package, switching in the same direction. This parameter is guaranteed by design.

TEST CIRCUITS AND WAVEFORMS

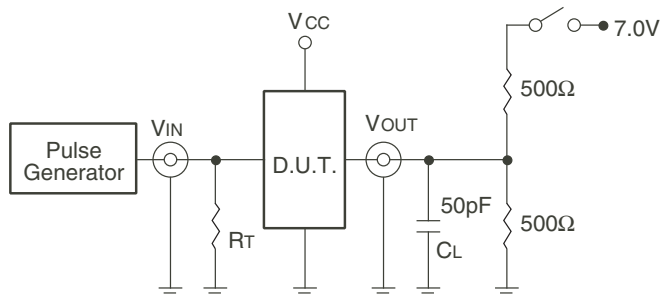

Test Circuits for All Outputs

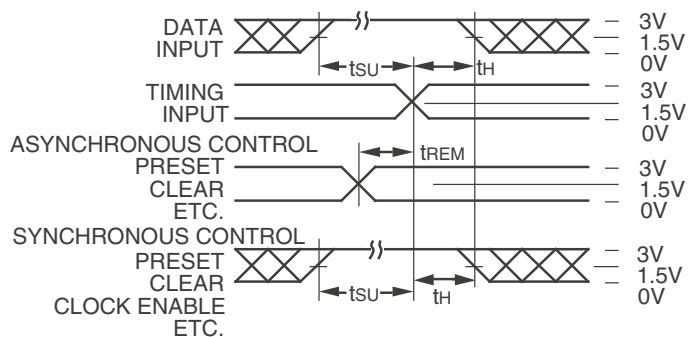

Set-up, Hold, and Release Times

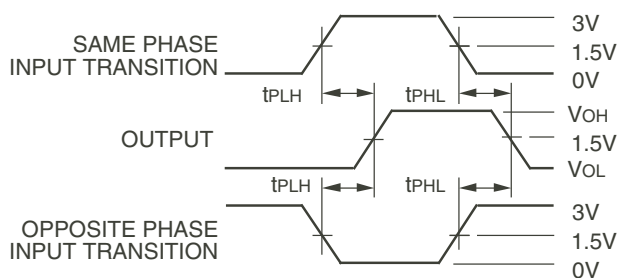

Propagation Delay

SWITCH POSITION

Test	Switch
Open Drain Disable Low Enable Low	Closed
All Other Tests	Open

DEFINITIONS:

CL = Load capacitance: includes jig and probe capacitance.

RT = Termination resistance: should be equal to Zout of the Pulse Generator.

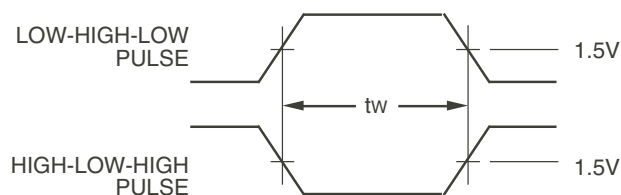

Pulse Width

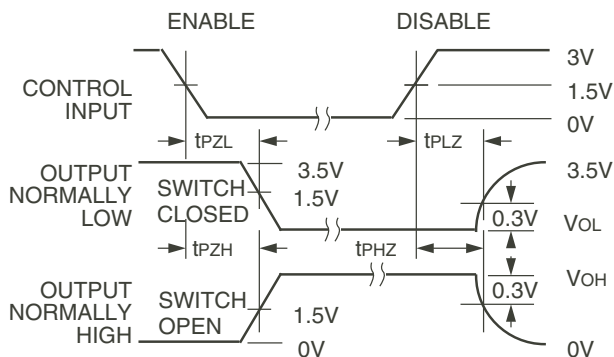

Enable and Disable Times

NOTES:

- Diagram shown for input Control Enable-LOW and input Control Disable-HIGH.
- Pulse Generator for All Pulses: Rate $\leq 1.0\text{MHz}$; $t_r \leq 2.5\text{ns}$; $t_s \leq 2.5\text{ns}$.

ORDERING INFORMATION

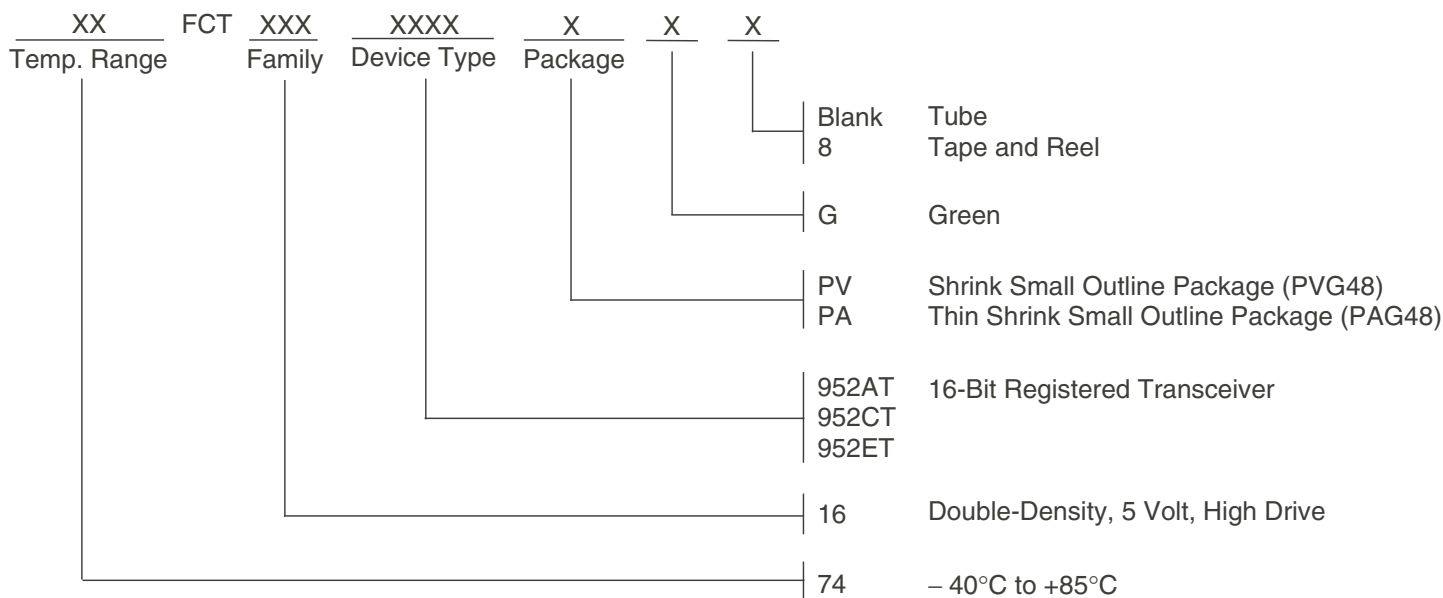

Orderable Part Information

Speed (ns)	Orderable Part ID	Pkg. Code	Pkg. Type	Temp. Grade
A	74FCT16952ATPAG	PAG56	TSSOP	I
	74FCT16952ATPAG8	PAG56	TSSOP	I
	74FCT16952ATPVG	PVG56	SSOP	I
	74FCT16952ATPVG8	PVG56	SSOP	I
C	74FCT16952CTPAG	PAG56	TSSOP	I
	74FCT16952CTPAG8	PAG56	TSSOP	I
	74FCT16952CTPVG	PVG56	SSOP	I
	74FCT16952CTPVG8	PVG56	SSOP	I
E	74FCT16952ETPAG	PAG56	TSSOP	I
	74FCT16952ETPAG8	PAG56	TSSOP	I
	74FCT16952ETPVG	PVG56	SSOP	I
	74FCT16952ETPVG8	PVG56	SSOP	I

Datasheet Document History

09/28/2009	Pg. 7	Updated the ordering information by removing the "IDT" notation and non RoHS part.
09/25/2017	Pg. 1, 2, 5, 7	Added table under pin configuration diagram with detailed package information. Updated the ordering information diagram by adding Tube, Tape and Reel. Added orderable part information table.
05/07/2018	Pg. 2-7	Corrected typo in device name header.

IMPORTANT NOTICE AND DISCLAIMER

RENESAS ELECTRONICS CORPORATION AND ITS SUBSIDIARIES (“RENESAS”) PROVIDES TECHNICAL SPECIFICATIONS AND RELIABILITY DATA (INCLUDING DATASHEETS), DESIGN RESOURCES (INCLUDING REFERENCE DESIGNS), APPLICATION OR OTHER DESIGN ADVICE, WEB TOOLS, SAFETY INFORMATION, AND OTHER RESOURCES “AS IS” AND WITH ALL FAULTS, AND DISCLAIMS ALL WARRANTIES, EXPRESS OR IMPLIED, INCLUDING, WITHOUT LIMITATION, ANY IMPLIED WARRANTIES OF MERCHANTABILITY, FITNESS FOR A PARTICULAR PURPOSE, OR NON-INFRINGEMENT OF THIRD PARTY INTELLECTUAL PROPERTY RIGHTS.

These resources are intended for developers skilled in the art designing with Renesas products. You are solely responsible for (1) selecting the appropriate products for your application, (2) designing, validating, and testing your application, and (3) ensuring your application meets applicable standards, and any other safety, security, or other requirements. These resources are subject to change without notice. Renesas grants you permission to use these resources only for development of an application that uses Renesas products. Other reproduction or use of these resources is strictly prohibited. No license is granted to any other Renesas intellectual property or to any third party intellectual property. Renesas disclaims responsibility for, and you will fully indemnify Renesas and its representatives against, any claims, damages, costs, losses, or liabilities arising out of your use of these resources. Renesas' products are provided only subject to Renesas' Terms and Conditions of Sale or other applicable terms agreed to in writing. No use of any Renesas resources expands or otherwise alters any applicable warranties or warranty disclaimers for these products.

(Disclaimer Rev.1.0 Mar 2020)

Corporate Headquarters

TOYOSU FORESIA, 3-2-24 Toyosu,
Koto-ku, Tokyo 135-0061, Japan
www.renesas.com

Contact Information

For further information on a product, technology, the most up-to-date version of a document, or your nearest sales office, please visit:
www.renesas.com/contact/

Trademarks

Renesas and the Renesas logo are trademarks of Renesas Electronics Corporation. All trademarks and registered trademarks are the property of their respective owners.