

MSP430F677xA, MSP430F676xA, MSP430F674xA Polyphase Metering SoCs

1 Device Overview

1.1 Features

- Accuracy < 0.1% Over 2000:1 Dynamic Range for Phase Current
- Meets or Exceeds ANSI C12.20 and IEC 62053 Standards
- Support for Multiple Sensors Such as Current Transformers, Rogowski Coils, or Shunts
- Power Measurement for up to Three Phases Plus Neutral
- Dedicated Pulse Output Pins for Active and Reactive Energy for Calibration
- 4-Quadrant Measurement per Phase or Cumulative
- Exact Phase-Angle Measurements
- Digital Phase Correction for Current Transformers
- Temperature-Compensated Energy Measurements
- 40-Hz to 70-Hz Line Frequency Range Using Single Calibration
- Flexible Power Supply Options With Automatic Switching
- Display Operates at Very Low Power During AC Mains Failure: 3 μ A in LPM3
- LCD Driver With Contrast Control for up to 320 Segments
- Password-Protected Real-Time Clock (RTC) With Tamper Detection, Crystal Offset Calibration, and Temperature Compensation
- Integrated Security Modules to Support Anti-Tamper and Encryption
- Multiple Communication Interfaces for Smart Meter Implementations
- High-Performance Analog
 - Up to Seven Independent 24-Bit Sigma-Delta ADCs With Differential Inputs and Variable Gain
 - 10-Bit 200-kSPS SAR ADC With Six External Channels and Two Internal Channels, Including Supply and Temperature Sensor Measurement
- Highly Integrated Digital
 - Three-Channel Direct Memory Access (DMA) Controller
 - Integrated Hardware AES-128 Module for Encryption
 - 16-Bit Cyclic Redundancy Check (CRC) Module
 - Four 16-Bit Timers With Nine Total Capture/Compare Registers
- Six Enhanced Universal Serial Communication Interfaces (eUSCIs)
 - eUSCI_A0, eUSCI_A1, eUSCI_A2, and eUSCI_A3 Support UART, IrDA, and SPI
 - eUSCI_B0, eUSCI_B1 Support SPI and I²C
- Ultra-Low Power Consumption
 - Multiple Low-Power Modes
 - Standby Mode (LPM3): 2.1 μ A at 3 V, Wake up in Less Than 5 μ s
 - RTC Mode (LPM3.5): 0.34 μ A at 3 V
 - Shutdown Mode (LPM4.5): 0.18 μ A at 3 V
- CPU
 - High-Performance 25-MHz CPU With 32-Bit Multiplier
 - Wide Input Supply Voltage Range: 3.6 V Down to 1.8 V
- Memory
 - Up to 512KB of Single-Cycle Flash
 - Up to 32KB of RAM With Single-Cycle Access
- Package Options
 - 128-Pin LQFP (PEU) Package With 90 I/O Pins
 - 100-Pin LQFP (PZ) Package With 62 I/O Pins
- Development Tools (Also See [Tools and Software](#))
 - Energy Measurement Design Center for MSP430 MCUs with 24-Bit Sigma-Delta ADCs ([MSP-EM-DESIGN-CENTER](#))
 - Three-Phase Electronic Watt-Hour EVM for Metering ([EVM430-F6779](#))
 - Target Development Board ([MSP-TS430PEU128](#))

1.2 Applications

- 3-Phase Electronic Watt-Hour Meters
- Utility Metering
- Energy Monitoring



1.3 Description

MSP430F67xxA polyphase metering SoCs are powerful highly integrated solutions that offer high accuracy and low system cost with few external components. The MSP430F67xxA microcontroller (MCU) family is part of the MSP430™ Metrology and Monitoring MCU portfolio targeting energy measurement and power monitoring applications including smart grid and building automation.

MSP430F67xxA MCUs feature up to seven independent 24-bit sigma-delta ADCs that can provide better than 0.1% accuracy. MSP430F67xxA devices integrate a high-performance MSP430 CPU with a 32-bit multiplier to perform all metrology calculations. Family members include up to 512KB of flash, 32KB of RAM, and an LCD controller with support for up to 320 segments.

The ultra-low power consumption of the MSP430F67xxA enables the system power supply to be minimized to reduce overall cost. Low standby power requires minimal energy storage, and critical data can be retained longer in case of a mains power failure.

The MSP430F67xxA MCU family is supported by an extensive software and hardware ecosystem. The Texas Instruments [Energy Measurement Design Center \(EMDC\)](#) can simplify development and accelerate designs by quickly configuring the [Energy Measurement software library](#), automatically generating code, performing calibration, and viewing results. MSP430F67xxA MCUs execute the Energy Measurement software library, which calculates all relevant energy and power results. Development kits include the [EVM430-F6779](#) three-phase electricity meter evaluation module and the [MSP-TS430PEU128](#) 128-pin target development board. Industry standard development tools and hardware platforms are available to speed development of meters that meet all of the ANSI and IEC standards globally.

For complete module descriptions, see the [MSP430F5xx and MSP430F6xx Family User's Guide](#).

Device Information⁽¹⁾

PART NUMBER	PACKAGE	BODY SIZE ⁽²⁾
MSP430F6779AIP EU	LQFP (128)	20 mm × 14 mm
MSP430F6779AIP Z	LQFP (100)	14 mm × 14 mm

- (1) For the most current part, package, and ordering information, see the *Package Option Addendum* in [Section 9](#), or see the TI website at www.ti.com.
(2) The dimensions shown here are approximations. For the package dimensions with tolerances, see the *Mechanical Data* in [Section 9](#).

1.4 Application Diagram

Figure 1-1 shows a typical application diagram.

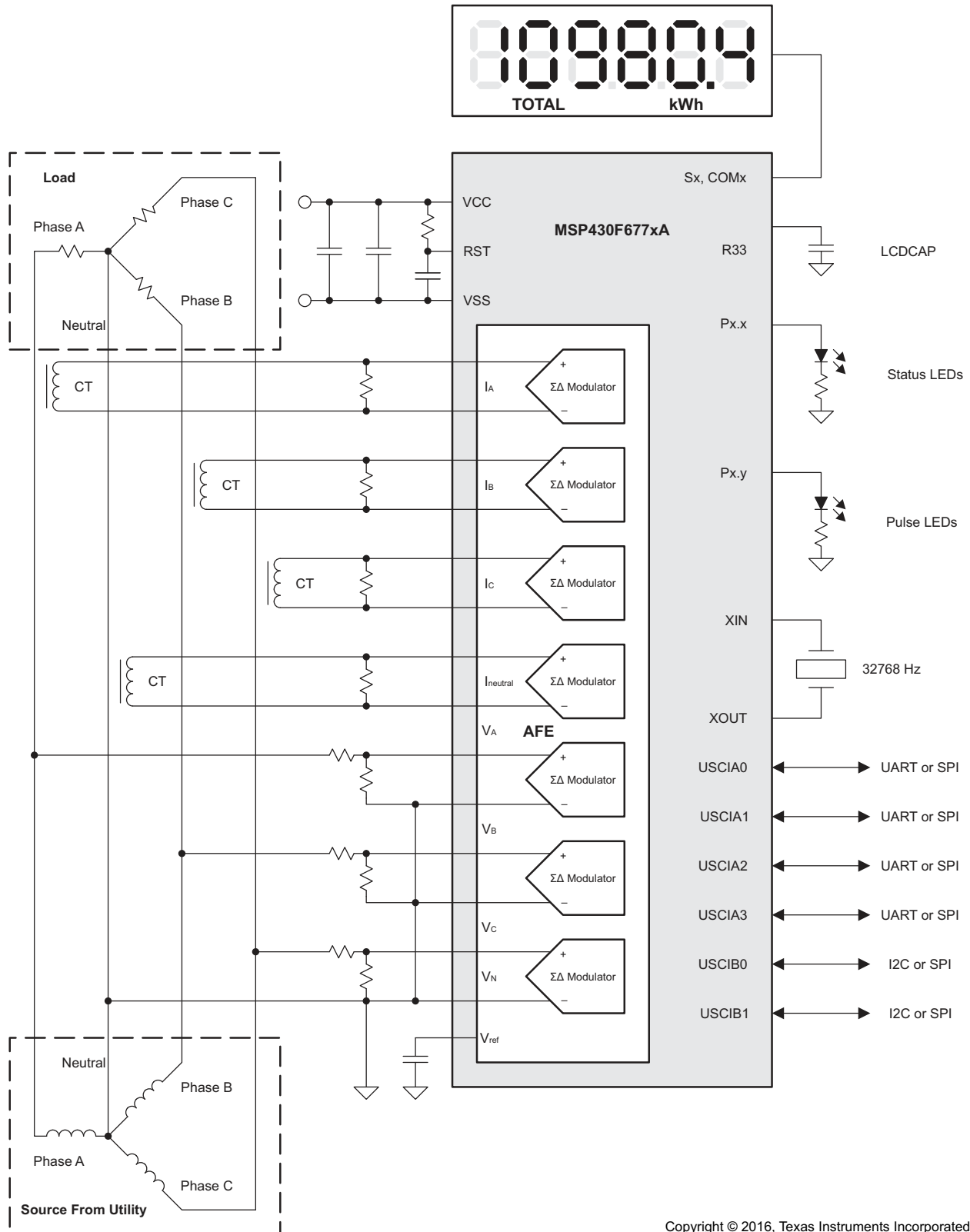

Copyright © 2016, Texas Instruments Incorporated

Figure 1-1. 3-Phase 4-Wire Star Connection Using MSP430F677xA

Table of Contents

1	Device Overview	1	5.17	ADC10_A.....	60
1.1	Features	1	5.18	REF.....	62
1.2	Applications.....	1	5.19	Comparator_B.....	63
1.3	Description.....	2	5.20	Flash	64
1.4	Application Diagram	3	5.21	Emulation and Debug	64
2	Revision History	5	6	Detailed Description	65
3	Device Comparison	6	6.1	Overview	65
3.1	Related Products	7	6.2	Functional Block Diagrams.....	66
4	Terminal Configuration and Functions	8	6.3	CPU (Link to User's Guide)	67
4.1	Pin Diagrams	8	6.4	Instruction Set.....	68
4.2	Signal Descriptions.....	12	6.5	Operating Modes.....	69
4.3	Pin Multiplexing	25	6.6	Interrupt Vector Addresses.....	70
4.4	Connection of Unused Pins	25	6.7	Special Function Registers (SFRs)	71
5	Specifications	26	6.8	Bootloader (BSL).....	72
5.1	Absolute Maximum Ratings	26	6.9	JTAG Operation	73
5.2	ESD Ratings	26	6.10	Memory.....	74
5.3	Recommended Operating Conditions.....	26	6.11	Peripherals	77
5.4	Active Mode Supply Current Into V _{CC} Excluding External Current.....	28	6.12	Input/Output Diagrams	103
5.5	Low-Power Mode Supply Currents (Into V _{CC}) Excluding External Current.....	29	6.13	Device Descriptors (TLV)	158
5.6	Low-Power Mode With LCD Supply Currents (Into V _{CC}) Excluding External Current.....	30	6.14	Identification.....	161
5.7	Thermal Resistance Characteristics	31	7	Applications, Implementation, and Layout	162
5.8	Timing and Switching Characteristics	32	8	Device and Documentation Support	163
5.9	Digital I/Os.....	36	8.1	Getting Started and Next Steps	163
5.10	Power-Management Module (PMM)	40	8.2	Device Nomenclature	163
5.11	Auxiliary Supplies	42	8.3	Tools and Software	165
5.12	Timer_A	45	8.4	Documentation Support.....	167
5.13	eUSCI	45	8.5	Related Links	169
5.14	RTC Tamper Detect Pin	51	8.6	Community Resources.....	169
5.15	LCD_C	52	8.7	Trademarks	169
5.16	SD24_B	54	8.8	Electrostatic Discharge Caution	169
			8.9	Glossary.....	169
			9	Mechanical, Packaging, and Orderable Information	170

2 Revision History

Changes from May 29, 2014 to September 28, 2018	Page
• Updated Section 1.1, Features	1
• Updated Section 1.3, Description	2
• Added Section 3.1, Related Products	7
• Corrected the port number (P4.2) on pin 61 in Figure 4-2, 100-Pin PZ Package (Top View)	10
• Added note to P1.3/ADC10CLK/A3 (pin 8) in Table 4-3, Terminal Functions – PEU Package	12
• Added typical conditions statements at the beginning of Section 5, Specifications	26
• Added SD24_B input pins and AUXVCCx pins to exception list on "Voltage applied to pins" parameter, and added SD24_B input pin limits in "Diode current at pins" parameter in Section 5.1, Absolute Maximum Ratings	26
• Added Section 5.2, ESD Ratings	26
• Added Section 5.7, Thermal Resistance Characteristics	31
• Updated notes (1) and (2) and added note (3) in Table 5-1, Wake-up Times From Low-Power Modes and Reset ..	32
• Changed the TYP value of the $C_{L,eff}$ parameter with Test Conditions of "XTS = 0, XCAPx = 0" from 2 pF to 1 pF in Table 5-2, Crystal Oscillator, XT1, Low-Frequency Mode	33
• Corrected bit name in Test Conditions of R_{CHARGE} parameter (changed CHCx to AUXCHCx) in Table 5-25, Auxiliary Supplies, Charge Limiting Resistor	44
• Replaced f_{Frame} parameter with f_{LCD} , $f_{FRAME,4mux}$, and $f_{FRAME,8mux}$ parameters in Table 5-37, LCD_C, Operating Conditions	52
• On the $V_{ID,FS}$ parameter in Table 5-39, SD24_B Power Supply and Recommended Operating Conditions : Changed the MIN value from " $V_{REF}/GAIN$ " to " $-V_{REF}/GAIN$ "; Removed "Unipolar mode" test condition (mode is not supported)	54
• Removed ADC10DIV from the formula for the TYP value in the second row of the $t_{CONVERT}$ parameter in Table 5-48, 10-Bit ADC, Switching Characteristics , because ADC10CLK is after division.....	60
• Changed Test Conditions for all parameters in Table 5-49, 10-Bit ADC Linearity Parameters : Removed " V_{REF-} "; Changed from " $(V_{eREF+} - V_{eREF-})_{min} \leq (V_{eREF+} - V_{eREF-})$ " to " $1.4 V \leq (V_{eREF+} - V_{eREF-})$ "; Changed from " $C_{VREF+} = 20 pF$ " to " $C_{V_{eREF+}} = 20 pF$ "; Added " $C_{V_{eREF+}} = 20 pF$ " to E_i ; Added "ADC10SREFX = 11b" to E_T and E_G	61
• Changed from " V_{REF-}/V_{eREF-} " to " V_{eREF-} " in Test Conditions for V_{eREF+} , V_{eREF-} , and $(V_{eREF+} - V_{eREF-})$ parameters in Table 5-50, 10-Bit ADC, External Reference	61
• Changed the MIN value of $A_{VCC(min)}$ with Test Conditions of "REFVSEL = {0} for 1.5 V" from 2.2 V to 1.8 V in Table 5-51, REF Built-In Reference	62
• Changed the MAX value of the $t_{EN,CMP}$ parameter with Test Conditions of "CBPWRMD = 10" from 50 μs to 100 μs in Table 5-52, Comparator_B	63
• Corrected the name of the RTC module (changed from RTC_CE to RTC_C) in Figure 6-1, Functional Block Diagram – PEU Package	66
• Corrected the name of the RTC module (changed from RTC_CE to RTC_C) in Figure 6-2, Functional Block Diagram – PZ Package	66
• Throughout document, changed all instances of "bootstrap loader" to "bootloader".....	72
• Corrected spelling of NMIFG in Table 6-13, System Module Interrupt Vector Registers	80
• Deleted mention of counter mode in Section 6.11.22, Real-Time Clock (RTC_C) (feature is not supported in this device)	85
• Replaced former section <i>Development Tools Support</i> with Section 8.3, Tools and Software	165
• Changed format and added content to Section 8.4, Documentation Support	167

3 Device Comparison

Table 3-1 summarizes the available family members.

Table 3-1. Device Comparison⁽¹⁾⁽²⁾

DEVICE	FLASH (KB)	SRAM (KB)	SD24_B CONVERTERS	ADC10_A CHANNELS	Timer_A ⁽³⁾	eUSCI		I/Os	PACKAGE
						CHANNEL A: UART, IrDA, SPI	CHANNEL B: SPI, I ² C		
MSP430F6779AIEU	512	32	7	6 ext, 2 int	3, 2, 2, 2	4	2	90	128 PEU
MSP430F6778AIEU	512	16	7	6 ext, 2 int	3, 2, 2, 2	4	2	90	128 PEU
MSP430F6777AIEU	256	32	7	6 ext, 2 int	3, 2, 2, 2	4	2	90	128 PEU
MSP430F6776AIEU	256	16	7	6 ext, 2 int	3, 2, 2, 2	4	2	90	128 PEU
MSP430F6775AIEU	128	16	7	6 ext, 2 int	3, 2, 2, 2	4	2	90	128 PEU
MSP430F6769AIEU	512	32	6	6 ext, 2 int	3, 2, 2, 2	4	2	90	128 PEU
MSP430F6768AIEU	512	16	6	6 ext, 2 int	3, 2, 2, 2	4	2	90	128 PEU
MSP430F6767AIEU	256	32	6	6 ext, 2 int	3, 2, 2, 2	4	2	90	128 PEU
MSP430F6766AIEU	256	16	6	6 ext, 2 int	3, 2, 2, 2	4	2	90	128 PEU
MSP430F6765AIEU	128	16	6	6 ext, 2 int	3, 2, 2, 2	4	2	90	128 PEU
MSP430F6749AIEU	512	32	4	6 ext, 2 int	3, 2, 2, 2	4	2	90	128 PEU
MSP430F6748AIEU	512	16	4	6 ext, 2 int	3, 2, 2, 2	4	2	90	128 PEU
MSP430F6747AIEU	256	32	4	6 ext, 2 int	3, 2, 2, 2	4	2	90	128 PEU
MSP430F6746AIEU	256	16	4	6 ext, 2 int	3, 2, 2, 2	4	2	90	128 PEU
MSP430F6745AIEU	128	16	4	6 ext, 2 int	3, 2, 2, 2	4	2	90	128 PEU
MSP430F6779AIPZ	512	32	7	6 ext, 2 int	3, 2, 2, 2	4	2	62	100 PZ
MSP430F6778AIPZ	512	16	7	6 ext, 2 int	3, 2, 2, 2	4	2	62	100 PZ
MSP430F6777AIPZ	256	32	7	6 ext, 2 int	3, 2, 2, 2	4	2	62	100 PZ
MSP430F6776AIPZ	256	16	7	6 ext, 2 int	3, 2, 2, 2	4	2	62	100 PZ
MSP430F6775AIPZ	128	16	7	6 ext, 2 int	3, 2, 2, 2	4	2	62	100 PZ
MSP430F6769AIPZ	512	32	6	6 ext, 2 int	3, 2, 2, 2	4	2	62	100 PZ
MSP430F6768AIPZ	512	16	6	6 ext, 2 int	3, 2, 2, 2	4	2	62	100 PZ
MSP430F6767AIPZ	256	32	6	6 ext, 2 int	3, 2, 2, 2	4	2	62	100 PZ
MSP430F6766AIPZ	256	16	6	6 ext, 2 int	3, 2, 2, 2	4	2	62	100 PZ
MSP430F6765AIPZ	128	16	6	6 ext, 2 int	3, 2, 2, 2	4	2	62	100 PZ
MSP430F6749AIPZ	512	32	4	6 ext, 2 int	3, 2, 2, 2	4	2	62	100 PZ
MSP430F6748AIPZ	512	16	4	6 ext, 2 int	3, 2, 2, 2	4	2	62	100 PZ
MSP430F6747AIPZ	256	32	4	6 ext, 2 int	3, 2, 2, 2	4	2	62	100 PZ
MSP430F6746AIPZ	256	16	4	6 ext, 2 int	3, 2, 2, 2	4	2	62	100 PZ
MSP430F6745AIPZ	128	16	4	6 ext, 2 int	3, 2, 2, 2	4	2	62	100 PZ

- (1) For the most current package and ordering information, see the *Package Option Addendum* in [Section 9](#), or see the TI website at www.ti.com.
- (2) Package drawings, thermal data, and symbolization are available at www.ti.com/packaging.
- (3) Each number in the sequence represents an instantiation of Timer_A with its associated number of capture/compare registers and PWM output generators available. For example, a number sequence of 3, 5 would represent two instantiations of Timer_A, the first instantiation having 3 and the second instantiation having 5 capture/compare registers and PWM output generators, respectively.

3.1 Related Products

For information about other devices in this family of products or related products, see the following links.

Products for TI Microcontrollers TI's low-power and high-performance MCUs, with wired and wireless connectivity options, are optimized for a broad range of applications.

Products for MSP430 Ultra-Low-Power Microcontrollers One platform. One ecosystem. Endless possibilities. Enabling the connected world with innovations in ultra-low-power microcontrollers with advanced peripherals for precise sensing and measurement.

Companion Products for MSP430F6779A Review products that are frequently purchased or used with this product.

Reference Designs for MSP430F6779A The TI Designs Reference Design Library is a robust reference design library that spans analog, embedded processor, and connectivity. Created by TI experts to help you jump start your system design, all TI Designs include schematic or block diagrams, BOMs, and design files to speed your time to market.

4 Terminal Configuration and Functions

4.1 Pin Diagrams

Figure 4-1 shows the pinout for the 128-pin PEU package. Table 4-1 summarizes the differences in the pinout among the device variants.

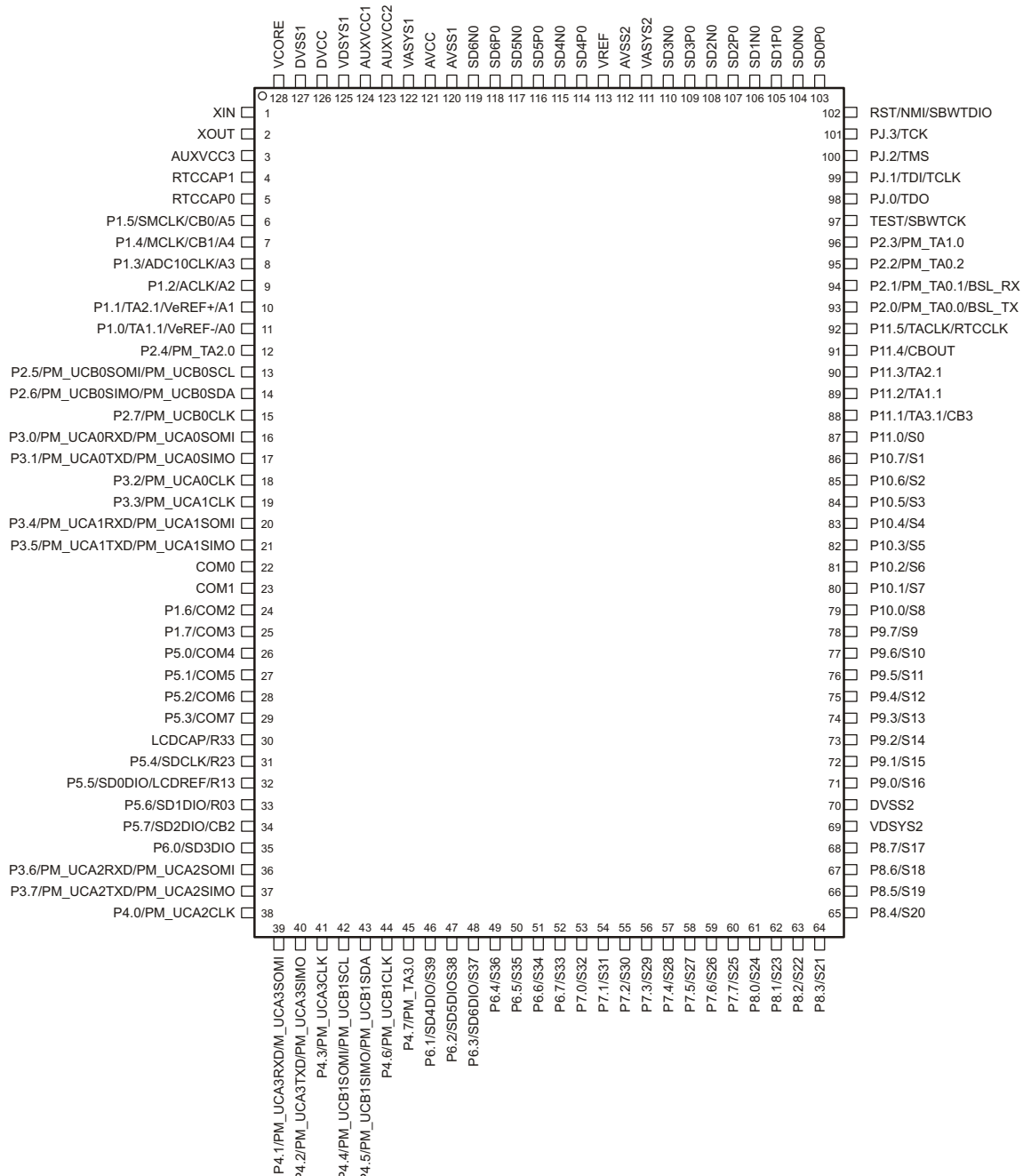

- The secondary digital functions on Ports P2, P3, and P4 are fully mappable. This pinout shows only the default mapping. See Section 6.11.6 for details.
- The pair of pins VDSYS1 and VDSYS2, VASYS1 and VASYS2 must be connected externally on board for proper device operation.
- CAUTION:** The LCDCAP/R33 pin must be connected to DVSS if it is not used.

Figure 4-1. 128-Pin PEU Package (Top View)

Table 4-1. Pinout Differences for PEU Package, F677xA, F676xA, and F674xA

PIN NUMBER	PIN NAME		
	MSP430F677xAIPEU	MSP430F676xAIPEU	MSP430F674xAIPEU
46	P6.1/SD4DIO/S39	P6.1/SD4DIO/S39	P6.1/S39
47	P6.2/SD5DIO/S38	P6.2/SD5DIO/S38	P6.2/S38
48	P6.3/SD6DIO/S37	P6.3/S37	P6.3/S37
113	VREF	VREF	VREF
114	SD4P0	SD4P0	NC
115	SD4N0	SD4N0	NC
116	SD5P0	SD5P0	NC
117	SD5N0	SD5NO	NC
118	SD6P0	NC	NC
119	SD6N0	NC	NC

Figure 4-2 shows the pinout for the 100-pin PZ package. Table 4-2 summarizes the differences in the pinout among the device variants.

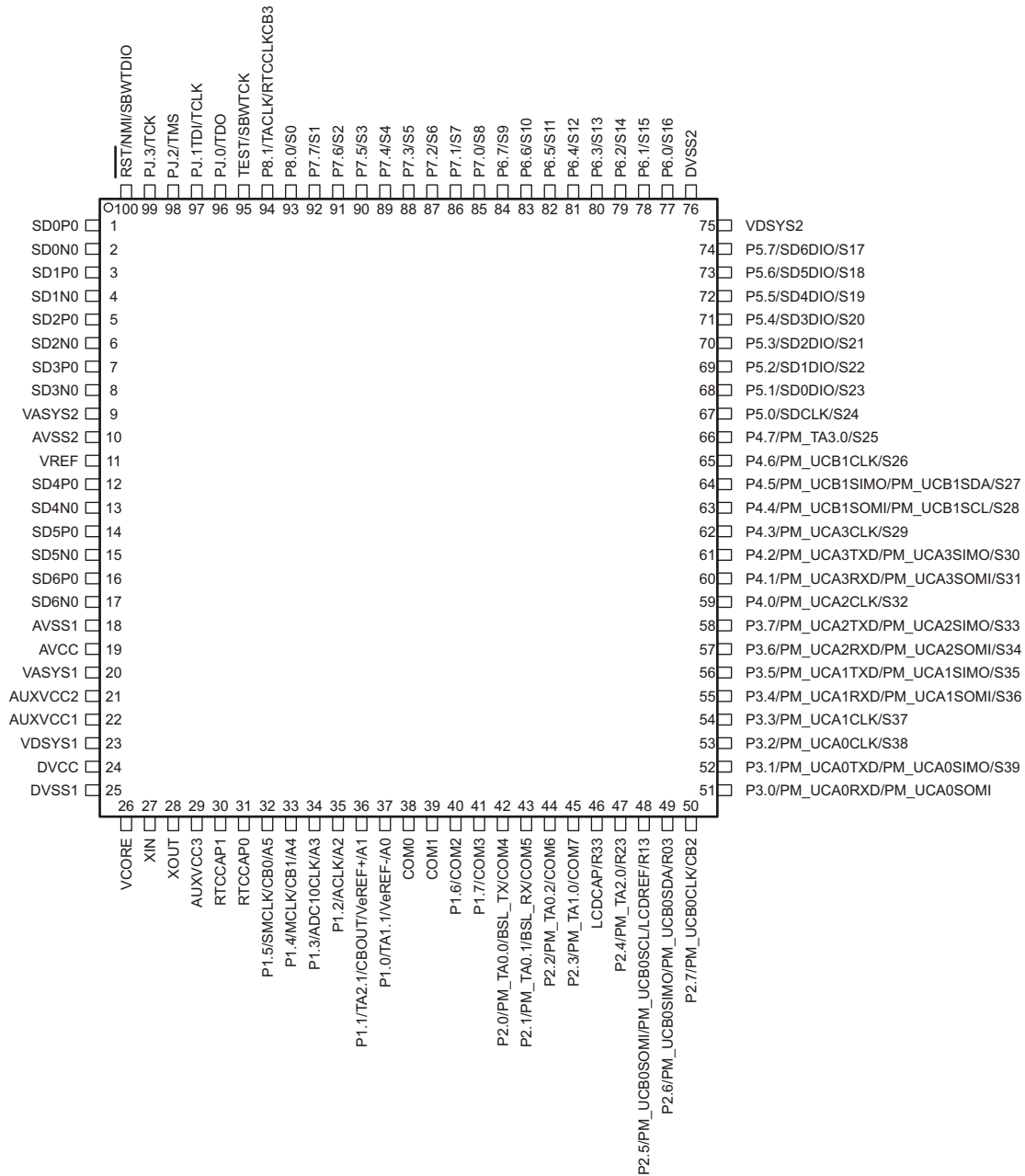

- The secondary digital functions on Ports P2, P3, and P4 are fully mappable. This pinout shows only the default mapping. See Section 6.11.6 for details.
- The pair of pins VDSYS1 and VDSYS2, VASYS1 and VASYS2 must be connected externally on board for proper device operation.
- CAUTION:** The LCDCAP/R33 pin must be connected to DVSS if it is not used.

Figure 4-2. 100-Pin PZ Package (Top View)

Table 4-2. Pinout Differences for PZ Package, F677xA, F676xA, and F674xA

PIN NUMBER	PIN NAME		
	MSP430F677xAIPZ	MSP430F676xAIPZ	MSP430F674xAIPZ
11	VREF	VREF	VREF
12	SD4P0	SD4P0	NC
13	SD4N0	SD4N0	NC
14	SD5P0	SD5P0	NC
15	SD5N0	SD5NO	NC
16	SD6P0	NC	NC
17	SD6N0	NC	NC
72	P5.5/SD4DIO/S19	P5.5/SD4DIO/S19	P5.5/S19
73	P5.6/SD5DIO/S18	P5.6/SD5DIO/S18	P5.6/S18
74	P5.7/SD6DIO/S17	P5.7/S17	P5.7/S17

4.2 Signal Descriptions

Table 4-3 describes the signals for devices in the PEU package. See Table 4-4 for the signals in the PZ package.

Table 4-3. Terminal Functions – PEU Package

TERMINAL		I/O ⁽¹⁾	DESCRIPTION
NAME	NO. PEU		
XIN	1	I/O	Input terminal for crystal oscillator
XOUT	2	I/O	Output terminal for crystal oscillator
AUXVCC3	3		Auxiliary power supply AUXVCC3 for backup subsystem
RTCCAP1	4	I	External time capture pin 1 for RTC_C
RTCCAP0	5	I	External time capture pin 0 for RTC_C
P1.5/SMCLK/CB0/A5	6	I/O	General-purpose digital I/O with port interrupt SMCLK clock output Comparator_B input CB0 Analog input A5 for 10-bit ADC
P1.4/MCLK/CB1/A4	7	I/O	General-purpose digital I/O with port interrupt MCLK clock output Comparator_B input CB1 Analog input A4 for 10-bit ADC
P1.3/ADC10CLK/A3 ⁽²⁾	8	I/O	General-purpose digital I/O with port interrupt ADC10_A clock output Analog input A3 for 10-bit ADC
P1.2/ACLK/A2	9	I/O	General-purpose digital I/O with port interrupt ACLK clock output Analog input A2 for 10-bit ADC
P1.1/TA2.1/VeREF+/A1	10	I/O	General-purpose digital I/O with port interrupt Timer TA2 CCR1 capture: CCI1A input, compare: Out1 output Positive terminal for the ADC reference voltage for an external applied reference voltage Analog input A1 for 10-bit ADC
P1.0/TA1.1/VeREF-/A0	11	I/O	General-purpose digital I/O with port interrupt Timer TA1 CCR1 capture: CCI1A input, compare: Out1 output Negative terminal for the ADC reference voltage for an external applied reference voltage Analog input A0 for 10-bit ADC
P2.4/PM_TA2.0	12	I/O	General-purpose digital I/O with port interrupt and mappable secondary function Default mapping: Timer TA2 capture CCR0: CCI0A input, compare: Out0 output
P2.5/PM_UCB0SOMI/ PM_UCB0SCL	13	I/O	General-purpose digital I/O with port interrupt and mappable secondary function Default mapping: eUSCI_B0 SPI slave out master in Default mapping: eUSCI_B0 I ² C clock
P2.6/PM_UCB0SIMO/ PM_UCB0SDA	14	I/O	General-purpose digital I/O with port interrupt and mappable secondary function Default mapping: eUSCI_B0 SPI slave in master out Default mapping: eUSCI_B0 I ² C data
P2.7/PM_UCB0CLK	15	I/O	General-purpose digital I/O with port interrupt and mappable secondary function Default mapping: eUSCI_B0 clock input/output

(1) I = input, O = output

(2) Before enabling the analog function (A3), pull this pin low by setting the port function to output low or to input with the internal pulldown resistor enabled.

Table 4-3. Terminal Functions – PEU Package (continued)

TERMINAL		I/O ⁽¹⁾	DESCRIPTION
NAME	NO. PEU		
P3.0/PM_UCA0RXD/ PM_UCA0SOMI	16	I/O	General-purpose digital I/O with mappable secondary function Default mapping: eUSCI_A0 UART receive data Default mapping: eUSCI_A0 SPI slave out master in
P3.1/PM_UCA0TXD/ PM_UCA0SIMO	17	I/O	General-purpose digital I/O with mappable secondary function Default mapping: eUSCI_A0 UART transmit data Default mapping: eUSCI_A0 SPI slave in master out
P3.2/PM_UCA0CLK	18	I/O	General-purpose digital I/O with mappable secondary function Default mapping: eUSCI_A0 clock input/output
P3.3/PM_UCA1CLK	19	I/O	General-purpose digital I/O with mappable secondary function Default mapping: eUSCI_A1 clock input/output
P3.4/PM_UCA1RXD/ PM_UCA1SOMI	20	I/O	General-purpose digital I/O with mappable secondary function Default mapping: eUSCI_A1 UART receive data Default mapping: eUSCI_A1 SPI slave out master in
P3.5/PM_UCA1TXD/ PM_UCA1SIMO	21	I/O	General-purpose digital I/O with mappable secondary function Default mapping: eUSCI_A1 UART transmit data Default mapping: eUSCI_A1 SPI slave in master out
COM0	22	O	LCD common output COM0 for LCD backplane
COM1	23	O	LCD common output COM1 for LCD backplane
P1.6/COM2	24	I/O	General-purpose digital I/O with port interrupt LCD common output COM2 for LCD backplane
P1.7/COM3	25	I/O	General-purpose digital I/O with port interrupt LCD common output COM3 for LCD backplane
P5.0/COM4	26	I/O	General-purpose digital I/O LCD common output COM4 for LCD backplane
P5.1/COM5	27	I/O	General-purpose digital I/O LCD common output COM5 for LCD backplane
P5.2/COM6	28	I/O	General-purpose digital I/O LCD common output COM6 for LCD backplane
P5.3/COM7	29	I/O	General-purpose digital I/O LCD common output COM7 for LCD backplane
LGDCAP/R33	30	I/O	LCD capacitor connection Input/output port of most positive analog LCD voltage (V1) CAUTION: This pin must be connected to DVSS if not used.
P5.4/SDCLK/R23	31	I/O	General-purpose digital I/O SD24_B bit-stream clock input/output Input/Output port of second most positive analog LCD voltage (V2)
P5.5/SD0DIO/ LCDREF/R13	32	I/O	General-purpose digital I/O SD24_B converter 0 bit-stream data input/output External reference voltage input for regulated LCD voltage Input/output port of third most positive analog LCD voltage (V3 or V4)
P5.6/SD1DIO/R03	33	I/O	General-purpose digital I/O SD24_B converter 1 bit-stream data input/output Input/output port of lowest analog LCD voltage (V5)

Table 4-3. Terminal Functions – PEU Package (continued)

TERMINAL		I/O ⁽¹⁾	DESCRIPTION
NAME	NO.		
	PEU		
P5.7/SD2DIO/CB2	34	I/O	General-purpose digital I/O SD24_B converter 2 bit-stream data input/output Comparator_B input CB2
P6.0/SD3DIO	35	I/O	General-purpose digital I/O SD24_B converter 3 bit-stream data input/output
P3.6/PM_UCA2RXD/ PM_UCA2SOMI	36	I/O	General-purpose digital I/O with mappable secondary function Default mapping: eUSCI_A2 UART receive data Default mapping: eUSCI_A2 SPI slave out master in
P3.7/PM_UCA2TXD/ PM_UCA2SIMO	37	I/O	General-purpose digital I/O with mappable secondary function Default mapping: eUSCI_A2 UART transmit data Default mapping: eUSCI_A2 SPI slave in master out
P4.0/PM_UCA2CLK	38	I/O	General-purpose digital I/O with mappable secondary function Default mapping: eUSCI_A2 clock input/output
P4.1/PM_UCA3RXD/ PM_UCA3SOMI	39	I/O	General-purpose digital I/O with mappable secondary function Default mapping: eUSCI_A3 UART receive data Default mapping: eUSCI_A3 SPI slave out master in
P4.2/PM_UCA3TXD/ PM_UCA3SIMO	40	I/O	General-purpose digital I/O with mappable secondary function Default mapping: eUSCI_A3 UART transmit data Default mapping: eUSCI_A3 SPI slave in master out
P4.3/PM_UCA3CLK	41	I/O	General-purpose digital I/O with mappable secondary function Default mapping: eUSCI_A3 clock input/output
P4.4/PM_UCB1SOMI/ PM_UCB1SCL	42	I/O	General-purpose digital I/O with mappable secondary function Default mapping: eUSCI_B1 SPI slave out, master in Default mapping: eUSCI_B1 I ² C clock
P4.5/PM_UCB1SIMO/ PM_UCB1SDA	43	I/O	General-purpose digital I/O with mappable secondary function Default mapping: eUSCI_B1 SPI slave in, master out Default mapping: eUSCI_B1 I ² C data
P4.6/PM_UCB1CLK	44	I/O	General-purpose digital I/O with mappable secondary function Default mapping: eUSCI_B1 clock input/output
P4.7/PM_TA3.0	45	I/O	General-purpose digital I/O with mappable secondary function Default mapping: Timer TA3 capture CCR0: CCI0A input, compare: Out0 output
P6.1/SD4DIO/S39	46	I/O	General-purpose digital I/O SD24_B converter 4 bit-stream data input/output (not available in F674xA devices) LCD segment output S39
P6.2/SD5DIO/S38	47	I/O	General-purpose digital I/O SD24_B converter 5 bit-stream data input/output (not available in F674xA devices) LCD segment output S38
P6.3/SD6DIO/S37	48	I/O	General-purpose digital I/O SD24_B converter 6 bit-stream data input/output (not available in F676xA, F674xA devices) LCD segment output S37
P6.4/S36	49	I/O	General-purpose digital I/O LCD segment output S36
P6.5/S35	50	I/O	General-purpose digital I/O LCD segment output S35

Table 4-3. Terminal Functions – PEU Package (continued)

TERMINAL		I/O ⁽¹⁾	DESCRIPTION
NAME	NO. PEU		
P6.6/S34	51	I/O	General-purpose digital I/O LCD segment output S34
P6.7/S33	52	I/O	General-purpose digital I/O LCD segment output S33
P7.0/S32	53	I/O	General-purpose digital I/O LCD segment output S32
P7.1/S31	54	I/O	General-purpose digital I/O LCD segment output S31
P7.2/S30	55	I/O	General-purpose digital I/O LCD segment output S30
P7.3/S29	56	I/O	General-purpose digital I/O LCD segment output S29
P7.4/S28	57	I/O	General-purpose digital I/O LCD segment output S28
P7.5/S27	58	I/O	General-purpose digital I/O LCD segment output S27
P7.6/S26	59	I/O	General-purpose digital I/O LCD segment output S26
P7.7/S25	60	I/O	General-purpose digital I/O LCD segment output S25
P8.0/S24	61	I/O	General-purpose digital I/O LCD segment output S24
P8.1/S23	62	I/O	General-purpose digital I/O LCD segment output S23
P8.2/S22	63	I/O	General-purpose digital I/O LCD segment output S22
P8.3/S21	64	I/O	General-purpose digital I/O LCD segment output S21
P8.4/S20	65	I/O	General-purpose digital I/O LCD segment output S20
P8.5/S19	66	I/O	General-purpose digital I/O LCD segment output S19
P8.6/S18	67	I/O	General-purpose digital I/O LCD segment output S18
P8.7/S17	68	I/O	General-purpose digital I/O LCD segment output S17
VDSYS2 ⁽³⁾	69		Digital power supply for I/Os
DVSS2	70		Digital ground supply
P9.0/S16	71	I/O	General-purpose digital I/O LCD segment output S16
P9.1/S15	72	I/O	General-purpose digital I/O LCD segment output S15
P9.2/S14	73	I/O	General-purpose digital I/O LCD segment output S14

(3) The pins VDSYS1 and VDSYS2 must be connected externally on board for proper device operation.

Table 4-3. Terminal Functions – PEU Package (continued)

TERMINAL		I/O ⁽¹⁾	DESCRIPTION
NAME	NO.		
	PEU		
P9.3/S13	74	I/O	General-purpose digital I/O LCD segment output S13
P9.4/S12	75	I/O	General-purpose digital I/O LCD segment output S12
P9.5/S11	76	I/O	General-purpose digital I/O LCD segment output S11
P9.6/S10	77	I/O	General-purpose digital I/O LCD segment output S10
P9.7/S9	78	I/O	General-purpose digital I/O LCD segment output S9
P10.0/S8	79	I/O	General-purpose digital I/O LCD segment output S8
P10.1/S7	80	I/O	General-purpose digital I/O LCD segment output S7
P10.2/S6	81	I/O	General-purpose digital I/O LCD segment output S6
P10.3/S5	82	I/O	General-purpose digital I/O LCD segment output S5
P10.4/S4	83	I/O	General-purpose digital I/O LCD segment output S4
P10.5/S3	84	I/O	General-purpose digital I/O LCD segment output S3
P10.6/S2	85	I/O	General-purpose digital I/O LCD segment output S2
P10.7/S1	86	I/O	General-purpose digital I/O LCD segment output S1
P11.0/S0	87	I/O	General-purpose digital I/O LCD segment output S0
P11.1/TA3.1/CB3	88	I/O	General-purpose digital I/O Timer TA3 capture CCR1: CCI1A input, compare: Out1 output Comparator_B input CB3
P11.2/TA1.1	89	I/O	General-purpose digital I/O Timer TA1 capture CCR1: CCI1A input, compare: Out1 output
P11.3/TA2.1	90	I/O	General-purpose digital I/O Timer TA2 capture CCR1: CCI1A input, compare: Out1 output
P11.4/CBOUT	91	I/O	General-purpose digital I/O Comparator_B output
P11.5/TACLK/RTCCLK	92	I/O	General-purpose digital I/O Timer clock input TACLK for TA0, TA1, TA2, TA3 RTCCLK clock output
P2.0/PM_TA0.0/BSL_TX	93	I/O	General-purpose digital I/O with port interrupt and mappable secondary function Default mapping: Timer TA0 capture CCR0: CCI0A input, compare: Out0 output Bootloader: Data transmit

Table 4-3. Terminal Functions – PEU Package (continued)

TERMINAL		I/O ⁽¹⁾	DESCRIPTION
NAME	NO. PEU		
P2.1/PM_TA0.1/BSL_RX	94	I/O	General-purpose digital I/O with port interrupt and mappable secondary function Default mapping: Timer TA0 capture CCR1: CCI1A input, compare: Out1 output Bootloader: Data receive
P2.2/PM_TA0.2	95	I/O	General-purpose digital I/O with port interrupt and mappable secondary function Default mapping: Timer TA0 capture CCR2: CCI2A input, compare: Out2 output
P2.3/PM_TA1.0	96	I/O	General-purpose digital I/O port interrupt and with mappable secondary function Default mapping: Timer TA1 capture CCR0: CCI0A input, compare: Out0 output
TEST/SBWTCK	97	I	Test mode pin – select digital I/O on JTAG pins Spy-Bi-Wire input clock
PJ.0/TDO	98	I/O	General-purpose digital I/O Test data output
PJ.1/TDI/TCLK	99	I/O	General-purpose digital I/O Test data input Test clock input
PJ.2/TMS	100	I/O	General-purpose digital I/O Test mode select
PJ.3/TCK	101	I/O	General-purpose digital I/O Test clock
$\overline{\text{RST}}$ /NMI/SBWDIO	102	I/O	Reset input, active-low ⁽⁴⁾ Nonmaskable interrupt input Spy-By-Wire data input/output
SD0P0	103	I	SD24_B positive analog input for converter 0 ⁽⁵⁾
SD0N0	104	I	SD24_B negative analog input for converter 0 ⁽⁵⁾
SD1P0	105	I	SD24_B positive analog input for converter 1 ⁽⁵⁾
SD1N0	106	I	SD24_B negative analog input for converter 1 ⁽⁵⁾
SD2P0	107	I	SD24_B positive analog input for converter 2 ⁽⁵⁾
SD2N0	108	I	SD24_B negative analog input for converter 2 ⁽⁵⁾
SD3P0	109	I	SD24_B positive analog input for converter 3 ⁽⁵⁾
SD3N0	110	I	SD24_B negative analog input for converter 3 ⁽⁴⁾
VASYS2	111		Analog power supply selected between AVCC, AUXVCC1, AUXVCC2. Connect recommended capacitor value of C _{VSYS} .
AVSS2	112		Analog ground supply
VREF	113	I	SD24_B external reference voltage
SD4P0	114	I	SD24_B positive analog input for converter 4 ⁽⁵⁾ (not available on F674xA devices)
SD4N0	115	I	SD24_B negative analog input for converter 4 ⁽⁵⁾ (not available on F674xA devices)
SD5P0	116	I	SD24_B positive analog input for converter 5 ⁽⁵⁾ (not available on F674xA devices)
SD5N0	117	I	SD24_B negative analog input for converter 5 ⁽⁵⁾ (not available on F674xA devices)
SD6P0	118	I	SD24_B positive analog input for converter 6 ⁽⁵⁾ (not available on F676xA, F674xA devices)
SD6N0	119	I	SD24_B negative analog input for converter 6 ⁽⁵⁾ (not available on F676xA, F674xA devices)
AVSS1	120		Analog ground supply
AVCC	121		Analog power supply
VASYS1	122		Analog power supply selected between AVCC, AUXVCC1, AUXVCC2. Connect recommended capacitor value of C _{VSYS} .
AUXVCC2	123		Auxiliary power supply AUXVCC2

(4) When this pin is configured as reset, the internal pullup resistor is enabled by default.

(5) TI recommends shorting unused analog input pairs and connecting them to analog ground.

Table 4-3. Terminal Functions – PEU Package (continued)

TERMINAL		I/O ⁽¹⁾	DESCRIPTION
NAME	NO.		
	PEU		
AUXVCC1	124		Auxiliary power supply AUXVCC1
VDSYS1 ⁽³⁾	125		Digital power supply selected between DVCC, AUXVCC1, AUXVCC2. Connect recommended capacitor value of C _{VSYS} .
DVCC	126		Digital power supply
DVSS1	127		Digital ground supply
VCORE ⁽⁶⁾	128		Regulated core power supply (internal use only, no external current loading)

(6) VCORE is for internal use only. No external current loading is possible. VCORE should only be connected to the recommended capacitor value, C_{VCORE}.

Table 4-4 describes the signals for devices in the PZ package. See Table 4-3 for the signals in the PEU package.

Table 4-4. Terminal Functions – PZ Package

TERMINAL		I/O ⁽¹⁾	DESCRIPTION
NAME	NO. PZ		
SD0P0	1	I	SD24_B positive analog input for converter 0 ⁽²⁾
SD0N0	2	I	SD24_B negative analog input for converter 0 ⁽²⁾
SD1P0	3	I	SD24_B positive analog input for converter 1 ⁽²⁾
SD1N0	4	I	SD24_B negative analog input for converter 1 ⁽²⁾
SD2P0	5	I	SD24_B positive analog input for converter 2 ⁽²⁾
SD2N0	6	I	SD24_B negative analog input for converter 2 ⁽²⁾
SD3P0	7	I	SD24_B positive analog input for converter 3 ⁽²⁾
SD3N0	8	I	SD24_B negative analog input for converter 3 ⁽²⁾
VASYS2	9		Analog power supply selected between AVCC, AUXVCC1, AUXVCC2. Connect recommended capacitor value of C _{VSYS} .
AVSS2	10		Analog ground supply
VREF	11	I	SD24_B external reference voltage
SD4P0	12	I	SD24_B positive analog input for converter 4 ⁽²⁾ (not available on F674x devices)
SD4N0	13	I	SD24_B negative analog input for converter 4 ⁽²⁾ (not available on F674xA devices)
SD5P0	14	I	SD24_B positive analog input for converter 5 ⁽²⁾ (not available on F674xA devices)
SD5N0	15	I	SD24_B negative analog input for converter 5 ⁽²⁾ (not available on F674xA devices)
SD6P0	16	I	SD24_B positive analog input for converter 6 ⁽²⁾ (not available on F676xA, F674xA devices)
SD6N0	17	I	SD24_B negative analog input for converter 6 ⁽²⁾ (not available on F676xA, F674xA devices)
AVSS1	18		Analog ground supply
AVCC	19		Analog power supply
VASYS1	20		Analog power supply selected between AVCC, AUXVCC1, AUXVCC2. Connect recommended capacitor value of C _{VSYS}
AUXVCC2	21		Auxiliary power supply AUXVCC2
AUXVCC1	22		Auxiliary power supply AUXVCC1
VDSYS1 ⁽³⁾	23		Digital power supply selected between DVCC, AUXVCC1, AUXVCC2. Connect recommended capacitor value of C _{VSYS} .
DVCC	24		Digital power supply
DVSS1	25		Digital ground supply
VCORE ⁽⁴⁾	26		Regulated core power supply (internal use only, no external current loading)
XIN	27	I/O	Input terminal for crystal oscillator
XOUT	28	I/O	Output terminal for crystal oscillator
AUXVCC3	29		Auxiliary power supply AUXVCC3 for backup subsystem
RTCCAP1	30	I	External time capture pin 1 for RTC_C
RTCCAP0	31	I	External time capture pin 0 for RTC_C
P1.5/SMCLK/CB0/A5	32	I/O	General-purpose digital I/O with port interrupt SMCLK clock output Comparator_B input CB0 Analog input A5 for 10-bit ADC

(1) I = input, O = output

(2) TI recommends shorting unused analog input pairs and connecting them to analog ground.

(3) The pins VDSYS1 and VDSYS2 must be connected externally on board for proper device operation.

(4) VCORE is for internal use only. No external current loading is possible. VCORE should only be connected to the recommended capacitor value, C_{VCORE}.

Table 4-4. Terminal Functions – PZ Package (continued)

TERMINAL		I/O ⁽¹⁾	DESCRIPTION
NAME	NO. PZ		
P1.4/MCLK/CB1/A4	33	I/O	General-purpose digital I/O with port interrupt MCLK clock output Comparator_B input CB1 Analog input A4 for 10-bit ADC
P1.3/ADC10CLK/A3	34	I/O	General-purpose digital I/O with port interrupt ADC10_A clock output Analog input A3 for 10-bit ADC
P1.2/ACLK/A2	35	I/O	General-purpose digital I/O with port interrupt ACLK clock output Analog input A2 for 10-bit ADC
P1.1/TA2.1/CBOUT/ VeREF+/A1	36	I/O	General-purpose digital I/O with port interrupt Timer TA2 CCR1 capture: CCI1A input, compare: Out1 output Comparator_B Output Positive terminal for the ADC reference voltage for an external applied reference voltage Analog input A1 for 10-bit ADC
P1.0/TA1.1/VeREF-/A0	37	I/O	General-purpose digital I/O with port interrupt Timer TA1 CCR1 capture: CCI1A input, compare: Out1 output Negative terminal for the ADC reference voltage for an external applied reference voltage Analog input A0 for 10-bit ADC
COM0	38	I/O	LCD common output COM0 for LCD backplane
COM1	39	I/O	LCD common output COM1 for LCD backplane
P1.6/COM2	40	I/O	General-purpose digital I/O with port interrupt LCD common output COM2 for LCD backplane
P1.7/COM3	41	I/O	General-purpose digital I/O with port interrupt LCD common output COM3 for LCD backplane
P2.0/PM_TA0.0/ BSL_TX/COM4	42	I/O	General-purpose digital I/O with port interrupt and mappable secondary function Default Mapping: Timer TA0 CCR0 capture: CCI0A input, compare: Out0 output Bootloader: Data transmit LCD common output COM4 for LCD backplane
P2.1/PM_TA0.1/ BSL_RX/COM5	43	I/O	General-purpose digital I/O with port interrupt and mappable secondary function Default Mapping: Timer TA0 CCR1 capture: CCI1A input, compare: Out1 output Bootloader: Data receive LCD common output COM5 for LCD backplane
P2.2/PM_TA0.2/COM6	44	I/O	General-purpose digital I/O with port interrupt and mappable secondary function Default Mapping: Timer TA0 CCR0 capture: CCI2A input, compare: Out2 output LCD common output COM6 for LCD backplane
P2.3/PM_TA1.0/COM7	45	I/O	General-purpose digital I/O with port interrupt and mappable secondary function Default Mapping: Timer TA1 CCR0 capture: CCI0A input, compare: Out0 output LCD common output COM7 for LCD backplane
LDCAP/R33	46	I/O	LCD capacitor connection Input/output port of most positive analog LCD voltage (V1) CAUTION: This pin must be connected to DVSS if not used.
P2.4/PM_TA2.0/R23	47	I/O	General-purpose digital I/O with port interrupt and mappable secondary function Default Mapping: Timer TA2 CCR0 capture: CCI0A input, compare: Out0 output Input/output port of second most positive analog LCD voltage (V2)

Table 4-4. Terminal Functions – PZ Package (continued)

TERMINAL		I/O ⁽¹⁾	DESCRIPTION
NAME	NO.		
	PZ		
P2.5/PM_UCB0SOMI/ PM_UCB0SCL/LCDREF/ R13	48	I/O	General-purpose digital I/O with port interrupt and mappable secondary function Default mapping: eUSCI_B0 SPI slave out, master in Default mapping: eUSCI_B0 I ² C clock External reference voltage input for regulated LCD voltage Input/output port of third most positive analog LCD voltage (V3 or V4)
P2.6/PM_UCB0SIMO/ PM_UCB0SDA/R03	49	I/O	General-purpose digital I/O with port interrupt and mappable secondary function Default mapping: eUSCI_B0 SPI slave in, master out Default mapping: eUSCI_B0 I ² C data Input/output port of lowest analog LCD voltage (V5)
P2.7/PM_UCB0CLK/CB2	50	I/O	General-purpose digital I/O with port interrupt and mappable secondary function Default mapping: eUSCI_B0 clock input/output Comparator_B input CB2
P3.0/PM_UCA0RXD/ PM_UCA0SOMI	51	I/O	General-purpose digital I/O with mappable secondary function Default mapping: eUSCI_A0 UART receive data Default mapping: eUSCI_A0 SPI slave out, master in
P3.1/PM_UCA0TXD/ PM_UCA0SIMO/S39	52	I/O	General-purpose digital I/O with mappable secondary function Default mapping: eUSCI_A0 UART transmit data Default mapping: eUSCI_A0 SPI slave in, master out LCD segment output S39
P3.2/PM_UCA0CLK/S38	53	I/O	General-purpose digital I/O with mappable secondary function Default mapping: eUSCI_A0 clock input/output LCD segment output S38
P3.3/PM_UCA1CLK/S37	54	I/O	General-purpose digital I/O with mappable secondary function Default mapping: eUSCI_A1 clock input/output LCD segment output S37
P3.4/PM_UCA1RXD/ PM_UCA1SOMI/S36	55	I/O	General-purpose digital I/O with mappable secondary function Default mapping: eUSCI_A1 UART receive data Default mapping: eUSCI_A1 SPI slave out, master in LCD segment output S36
P3.5/PM_UCA1TXD/ PM_UCA1SIMO/S35	56	I/O	General-purpose digital I/O with mappable secondary function Default mapping: eUSCI_A1 UART transmit data Default mapping: eUSCI_A1 SPI slave in, master out LCD segment output S35
P3.6/PM_UCA2RXD/ PM_UCA2SOMI/S34	57	I/O	General-purpose digital I/O with mappable secondary function Default mapping: eUSCI_A2 UART receive data Default mapping: eUSCI_A2 SPI slave out, master in LCD segment output S34
P3.7/PM_UCA2TXD/ PM_UCA2SIMO/S33	58	I/O	General-purpose digital I/O with mappable secondary function Default mapping: eUSCI_A2 UART transmit data Default mapping: eUSCI_A2 SPI slave in, master out LCD segment output S33
P4.0/PM_UCA2CLK/S32	59	I/O	General-purpose digital I/O with mappable secondary function Default mapping: eUSCI_A2 clock input/output LCD segment output S32

Table 4-4. Terminal Functions – PZ Package (continued)

TERMINAL		I/O ⁽¹⁾	DESCRIPTION
NAME	NO.		
	PZ		
P4.1/PM_UCA3RXD/ PM_UCA3SOMI/S31	60	I/O	General-purpose digital I/O with mappable secondary function Default mapping: eUSCI_A3 UART receive data Default mapping: eUSCI_A3 SPI slave out, master in LCD segment output S31
P4.2/PM_UCA3TXD/ PM_UCA3SIMO/S30	61	I/O	General-purpose digital I/O with mappable secondary function Default mapping: eUSCI_A3 UART transmit data Default mapping: eUSCI_A3 SPI slave in, master out LCD segment output S30
P4.3/PM_UCA3CLK/S29	62	I/O	General-purpose digital I/O with mappable secondary function Default mapping: eUSCI_A3 clock input/output LCD segment output S29
P4.4/PM_UCB1SOMI/ PM_UCB1SCL/S28	63	I/O	General-purpose digital I/O with mappable secondary function Default mapping: eUSCI_B1 SPI slave out, master in Default mapping: eUSCI_B1 I ² C clock LCD segment output S28
P4.5/PM_UCB1SIMO/ PM_UCB1SDA/S27	64	I/O	General-purpose digital I/O with mappable secondary function Default mapping: eUSCI_B1 SPI slave in, master out Default mapping: eUSCI_B1 I ² C data LCD segment output S27
P4.6/PM_UCB1CLK/S26	65	I/O	General-purpose digital I/O with mappable secondary function Default mapping: eUSCI_B1 clock input/output LCD segment output S26
P4.7/PM_TA3.0/S25	66	I/O	General-purpose digital I/O with mappable secondary function Default Mapping: Timer TA3 CCR0 capture: CCI0A input, compare: Out0 output LCD segment output S25
P5.0/SDCLK/S24	67	I/O	General-purpose digital I/O SD24_B bit-stream clock input/output LCD segment output S24
P5.1/PM_SD0DIO/S23	68	I/O	General-purpose digital I/O Default mapping: SD24_B converter 0 bit-stream data input/output LCD segment output S23
P5.2/PM_SD1DIO/S22	69	I/O	General-purpose digital I/O Default mapping: SD24_B converter 1 bit-stream data input/output LCD segment output S22
P5.3/PM_SD2DIO/S21	70	I/O	General-purpose digital I/O Default mapping: SD24_B converter 2 bit-stream data input/output LCD segment output S21
P5.4/PM_SD3DIO/S20	71	I/O	General-purpose digital I/O Default mapping: SD24_B converter 3 bit-stream data input/output LCD segment output S20
P5.5/PM_SD4DIO/S19	72	I/O	General-purpose digital I/O Default mapping: SD24_B converter 4 bit-stream data input/output (not available on F674xA devices) LCD segment output S19

Table 4-4. Terminal Functions – PZ Package (continued)

TERMINAL		I/O ⁽¹⁾	DESCRIPTION
NAME	NO. PZ		
P5.6/PM_SD5DIO/S18	73	I/O	General-purpose digital I/O Default mapping: SD24_B converter 5 bit-stream data input/output (not available on F674xA devices) LCD segment output S18
P5.7/PM_SD6DIO/S17	74	I/O	General-purpose digital I/O Default mapping: SD24_B converter 6 bit-stream data input/output (not available on F676xA or F674xA devices) LCD segment output S17
VDSYS2 ⁽³⁾	75		Digital power supply for I/Os
DVSS2	76		Digital ground supply
P6.0/S16	77	I/O	General-purpose digital I/O LCD segment output S16
P6.1/S15	78	I/O	General-purpose digital I/O LCD segment output S15
P6.2/S14	79	I/O	General-purpose digital I/O LCD segment output S14
P6.3/S13	80	I/O	General-purpose digital I/O LCD segment output S13
P6.4/S12	81	I/O	General-purpose digital I/O LCD segment output S12
P6.5/S11	82	I/O	General-purpose digital I/O LCD segment output S11
P6.6/S10	83	I/O	General-purpose digital I/O LCD segment output S10
P6.7/S9	84	I/O	General-purpose digital I/O LCD segment output S9
P7.0/S8	85	I/O	General-purpose digital I/O LCD segment output S8
P7.1/S7	86	I/O	General-purpose digital I/O LCD segment output S7
P7.2/S6	87	I/O	General-purpose digital I/O LCD segment output S6
P7.3/S5	88	I/O	General-purpose digital I/O LCD segment output S5
P7.4/S4	89	I/O	General-purpose digital I/O LCD segment output S4
P7.5/S3	90	I/O	General-purpose digital I/O LCD segment output S3
P7.6/S2	91	I/O	General-purpose digital I/O LCD segment output S2
P7.7/S1	92	I/O	General-purpose digital I/O LCD segment output S1
P8.0/S0	93	I/O	General-purpose digital I/O LCD segment output S0

Table 4-4. Terminal Functions – PZ Package (continued)

TERMINAL		I/O ⁽¹⁾	DESCRIPTION
NAME	NO. PZ		
P8.1/TACLK/RTCCLK/CB3	94	I/O	General-purpose digital I/O Timer clock input TACLK for TA0, TA1, TA2, TA3 RTCCLK clock output Comparator_B input CB3
TEST/SBWTK	95	I	Test mode pin – select digital I/O on JTAG pins Spy-By-Wire input clock
PJ.0/TDO	96	I/O	General-purpose digital I/O Test data output
PJ.1/TDI/TCLK	97	I/O	General-purpose digital I/O Test data input or Test clock input
PJ.2/TMS	98	I/O	General-purpose digital I/O Test mode select
PJ.3/TCK	99	I/O	General-purpose digital I/O Test clock
$\overline{\text{RST}}$ /NMI/SBWDIO	100	I/O	Reset input active low ⁽⁵⁾ Nonmaskable interrupt input Spy-By-Wire data input/output

(5) When this pin is configured as reset, the internal pullup resistor is enabled by default.

4.3 Pin Multiplexing

Pin multiplexing for these devices is controlled by both register settings and operating modes (for example, if the device is in test mode). For details of the settings for each pin and schematics of the multiplexed ports, see [Section 6.12](#).

4.4 Connection of Unused Pins

[Table 4-5](#) lists the correct termination of unused pins.

Table 4-5. Connection of Unused Pins⁽¹⁾

PIN	POTENTIAL	COMMENT
AVCC	DV _{CC}	
AVSS	DV _{SS}	
Px.y	Open	Switched to port function, output direction (PxDIR.n = 1). Px.y represents port x and bit y of port x (for example, P1.0, P1.1, P2.2, PJ.0, PJ.1)
XIN	DV _{SS}	For dedicated XIN pins only. XIN pins with shared GPIO functions should be programmed to GPIO and follow Px.y recommendations.
XOUT	Open	For dedicated XOUT pins only. XOUT pins with shared GPIO functions should be programmed to GPIO and follow Px.y recommendations.
LDCAP	DV _{SS}	
$\overline{\text{RST}}$ /NMI	DV _{CC} or V _{CC}	47-k Ω pullup or internal pullup selected with 10-nF (2.2 nF) pulldown ⁽²⁾
PJ.0/TDO PJ.1/TDI PJ.2/TMS PJ.3/TCK	Open	The JTAG pins are shared with general-purpose I/O function (PJ.x). If not being used, these should be switched to port function, output direction (PJDIR.n = 1). When used as JTAG pins, these pins should remain open.
TEST	Open	This pin always has an internal pulldown enabled.

- (1) Any unused pin with a secondary function that is shared with general-purpose I/O should follow the Px.y unused pin connection guidelines.
- (2) The pulldown capacitor should not exceed 2.2 nF when using devices with Spy-Bi-Wire interface in Spy-Bi-Wire mode or in 4-wire JTAG mode with TI tools such as FET interfaces or GANG programmers.

5 Specifications

All graphs in this section are for typical conditions, unless otherwise noted.

Typical (TYP) values are specified at $V_{CC} = 3.3\text{ V}$ and $T_A = 25^\circ\text{C}$, unless otherwise noted.

5.1 Absolute Maximum Ratings

over operating free-air temperature range (unless otherwise noted)⁽¹⁾

		MIN	MAX	UNIT
Voltage applied at DVCC to DVSS		-0.3	4.1	V
Voltage applied to pins ⁽²⁾	All pins except V _{CORE} ⁽³⁾ , SD24_B input pins (SDxN0, SDxP0) ⁽⁴⁾ , AUXVCC1, AUXVCC2, and AUXVCC3 ⁽⁵⁾	-0.3	$V_{CC} + 0.3$	V
Diode current at pins	All pins except SD24_B input pins (SDxN0, SDxP0)		±2	mA
	SD0N0, SD0P0, SD1N0, SD1P0, SD2N0, SD2P0, SD3N0, SD3P0, SD4N0, SD4P0, SD5N0, SD5P0, SD6N0, SD6P0 ⁽⁶⁾		2	
Maximum junction temperature, T _J			95	°C
Storage temperature, T _{stg} ⁽⁷⁾		-55	105	°C

- (1) Stresses beyond those listed under *Absolute Maximum Ratings* may cause permanent damage to the device. These are stress ratings only, and functional operation of the device at these or any other conditions beyond those indicated under *Recommended Operating Conditions* is not implied. Exposure to absolute-maximum-rated conditions for extended periods may affect device reliability.
- (2) All voltages referenced to $V_{SS} = V_{DVSS} = V_{AVSS}$.
- (3) V_{CORE} is for internal device use only. No external DC loading or voltage should be applied.
- (4) See [Table 5-39](#) for SD24_B specifications.
- (5) See [Table 5-18](#) for AUX specifications.
- (6) A protection diode is connected to V_{CC} for the SD24_B input pins. No protection diode is connected to V_{SS} .
- (7) Higher temperature may be applied during board soldering according to the current JEDEC J-STD-020 specification with peak reflow temperatures not higher than classified on the device label on the shipping boxes or reels.

5.2 ESD Ratings

		VALUE	UNIT
V _(ESD) Electrostatic discharge	Human-body model (HBM), per ANSI/ESDA/JEDEC JS-001 ⁽¹⁾	±1000	V
	Charged-device model (CDM), per JEDEC specification JESD22-C101 ⁽²⁾	±250	

- (1) JEDEC document JEP155 states that 500-V HBM allows safe manufacturing with a standard ESD control process. Pins listed as ±1000 V may actually have higher performance.
- (2) JEDEC document JEP157 states that 250-V CDM allows safe manufacturing with a standard ESD control process. Pins listed as ±250 V may actually have higher performance.

5.3 Recommended Operating Conditions

		MIN	NOM	MAX	UNIT
V _{CC}	Supply voltage during program execution and flash programming ($V_{AVCC} = V_{DVCC} = V_{CC}$) ⁽¹⁾⁽²⁾	PMMCOREVx = 0	1.8	3.6	V
		PMMCOREVx = 0, 1	2.0	3.6	
		PMMCOREVx = 0, 1, 3 2	2.2	3.6	
		PMMCOREVx = 0, 1, 2, 3	2.4	3.6	
V _{SS}	Supply voltage $V_{AVSS} = V_{DVSS} = V_{SS}$		0		V
T _A	Operating free-air temperature	I version	-40	85	°C
T _J	Operating junction temperature	I version	-40	85	°C
C _{VCORE}	Recommended capacitor at V _{CORE}		470		nF
$\frac{C_{DVCC}}{C_{VCORE}}$	Capacitor ratio of DVCC to V _{CORE}		10		

- (1) TI recommends powering AVCC and DVCC from the same source. A maximum difference of 0.3 V between $V_{(AVCC)}$ and $V_{(DVCC)}$ can be tolerated during power up and operation.
- (2) The minimum supply voltage is defined by the supervisor SVS levels when it is enabled. See the [Table 5-14](#) threshold parameters for the exact values and further details.

Recommended Operating Conditions (continued)

		MIN	NOM	MAX	UNIT	
f _{SYSTEM}	Processor frequency (maximum MCLK frequency) ⁽³⁾ (4) (see Figure 5-1)	PMMCOREVx = 0, 1.8 V ≤ V _{CC} ≤ 3.6 V (default condition)		0	8.0	MHz
		PMMCOREVx = 1, 2 V ≤ V _{CC} ≤ 3.6 V		0	12.0	
		PMMCOREVx = 2, 2.2 V ≤ V _{CC} ≤ 3.6 V		0	20.0	
		PMMCOREVx = 3, 2.4 V ≤ V _{CC} ≤ 3.6 V		0	25.0	
I _{LOAD, DVCCD}	Maximum load current that can be drawn from DVCC for core and IO (I _{LOAD} = I _{CORE} + I _{IO})			20	mA	
I _{LOAD, AUX1D}	Maximum load current that can be drawn from AUXVCC1 for core and IO (I _{LOAD} = I _{CORE} + I _{IO})			20	mA	
I _{LOAD, AUX2D}	Maximum load current that can be drawn from AUXVCC2 for core and IO (I _{LOAD} = I _{CORE} + I _{IO})			20	mA	
I _{LOAD, AVCCA}	Maximum load current that can be drawn from AVCC for analog modules (I _{LOAD} = I _{Modules})			10	mA	
I _{LOAD, AUX1A}	Maximum load current that can be drawn from AUXVCC1 for analog modules (I _{LOAD} = I _{Modules})			5	mA	
I _{LOAD, AUX2A}	Maximum load current that can be drawn from AUXVCC2 for analog modules (I _{LOAD} = I _{Modules})			5	mA	
P _{INT}	Internal power dissipation			V _{CC} × I _(DVCC)	W	
P _{IO}	I/O power dissipation of the I/O pins powered by DVCC			(V _{CC} - V _{IOH}) × I _{IOH} + V _{IO L} × I _{IO L}	W	
P _{MAX}	Maximum allowed power dissipation, P _{MAX} > P _{IO} + P _{INT}			(T _J - T _A) / θ _{JA}	W	

- (3) The MSP430 CPU is clocked directly with MCLK. Both the high and low phase of MCLK must not exceed the pulse duration of the specified maximum frequency.
- (4) Modules may have a different maximum input clock specification. See the specification of the respective module in this data sheet.

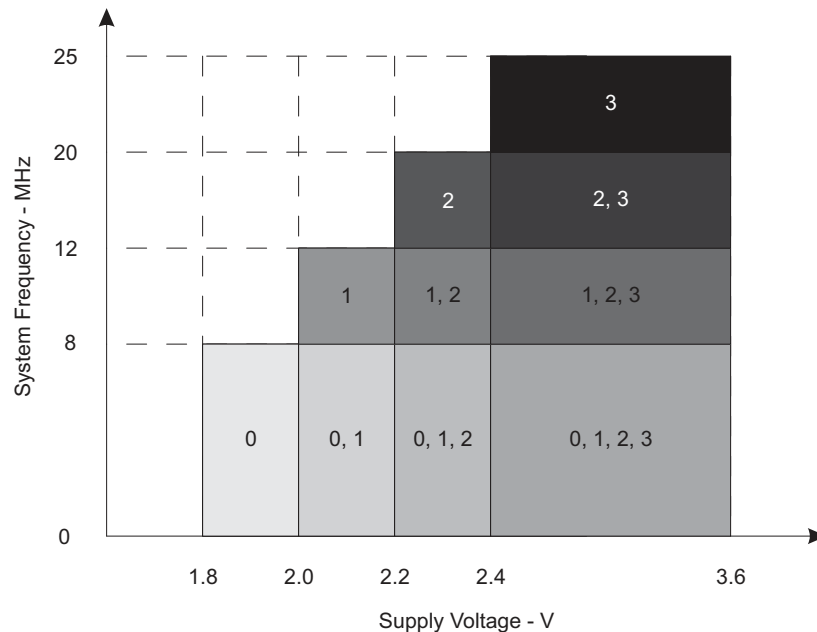

The numbers within the fields denote the supported PMMCOREVx settings.

Figure 5-1. Maximum System Frequency

5.4 Active Mode Supply Current Into V_{CC} Excluding External Current

over recommended operating free-air temperature (unless otherwise noted)⁽¹⁾⁽²⁾⁽³⁾

PARAMETER	EXECUTION MEMORY	V_{CC}	PMMCOREV _x	FREQUENCY ($f_{DCO} = f_{MCLK} = f_{SMCLK}$)								UNIT		
				1 MHz		8 MHz		12 MHz		20 MHz			25 MHz	
				TYP	MAX	TYP	MAX	TYP	MAX	TYP	MAX		TYP	MAX
$I_{AM, Flash}^{(4)}$	Flash	3 V	0	0.32	0.50	2.08	2.84							mA
			1	0.35		2.35		3.50	4.76					
			2	0.39		2.68		3.99		6.61	8.3			
			3	0.41		2.83		4.22		6.98		8.67	11.75	
$I_{AM, RAM}^{(5)}$	RAM	3 V	0	0.19		1.04							mA	
			1	0.21		1.20		1.77						
			2	0.23		1.38		2.04		3.35				
			3	0.24		1.47		2.18		3.58		4.44		

- (1) All inputs are tied to 0 V or to V_{CC} . Outputs do not source or sink any current.
- (2) The currents are characterized with a Micro Crystal MS1 V-T1K crystal with a load capacitance of 12.5 pF. The internal and external load capacitance are chosen to closely match the required 12.5 pF.
- (3) Characterized with program executing typical data processing.
 $f_{ACLK} = 32786$ Hz, $f_{DCO} = f_{MCLK} = f_{SMCLK}$ at specified frequency.
 $XTS = CPUOFF = SCG0 = SCG1 = OSCOFF = SMCLKOFF = 0$.
- (4) Active mode supply current when program executes in flash at a nominal supply voltage of 3.0 V.
- (5) Active mode supply current when program executes in RAM at a nominal supply voltage of 3.0 V.

5.5 Low-Power Mode Supply Currents (Into V_{CC}) Excluding External Current

over recommended ranges of supply voltage and operating free-air temperature (unless otherwise noted)⁽¹⁾⁽²⁾

PARAMETER	V_{CC}	PMMCOREVx	TEMPERATURE (T_A)						UNIT
			-40°C		25°C		85°C		
			TYP	MAX	TYP	MAX	TYP	MAX	
$I_{LPM0,1MHz}$ Low-power mode 0 ^{(3) (4)}	2.2 V	0	70		75		86		μA
	3 V	3	81		87	105	100	130	
I_{LPM2} Low-power mode 2 ^{(5) (4)}	2.2 V	0	5.9		6.5		12.5		μA
	3 V	3	6.7		7.3	18	13.8	30	
$I_{LPM3,XT1LF}$ Low-power mode 3, crystal mode ^{(6) (4)}	2.2 V	0	1.50		2.0		7.8		μA
		1	1.65		2.2		8.3		
		2	1.80		2.4		8.6		
		3	1.84		2.4		8.6		
$I_{LPM3,XT1LF}$ Low-power mode 3, crystal mode ^{(6) (4)}	3 V	0	2.0		2.5		8.5		μA
		1	2.1		2.7		9.0		
		2	2.3		2.9		9.3		
		3	2.3		2.9		9.3	25	
$I_{LPM3,VLO}$ Low-power mode 3, VLO mode ^{(7) (4)}	3 V	0	1.3		1.7		7.5		μA
		1	1.3		1.8		7.9		
		2	1.4		1.9		8.2		
		3	1.4		1.9		8.2	25.0	
I_{LPM4} Low-power mode 4 ^{(8) (4)}	3 V	0	1.2		1.6		7.4		μA
		1	1.2		1.7		7.8		
		2	1.3		1.7		7.9		
		3	1.3		1.7		8.0	23.0	
$I_{LPM3.5}$ Low-power mode 3.5, RTC active on AUXVCC3 ⁽⁹⁾	2.2 V		0.7		0.9		1.4		μA
	3 V		1.0		1.2	1.5	1.8	3.0	
$I_{LPM4.5}$ Low-power mode 4.5 ⁽¹⁰⁾	3 V		0.6		0.7	1.0	1.2	2.0	μA

(1) All inputs are tied to 0 V or to V_{CC} . Outputs do not source or sink any current.

(2) The currents are characterized with a Micro Crystal MS1 V-T1K crystal with a load capacitance of 12.5 pF. The internal and external load capacitance are chosen to closely match the required 12.5 pF.

(3) Current for watchdog timer clocked by SMCLK included. ACLK = low frequency crystal operation (XTS = 0, XT1DRIVE_x = 0). CPUOFF = 1, SCG0 = 0, SCG1 = 0, OSCOFF = 0 (LPM0), f_{ACLK} = 32768 Hz, f_{MCLK} = 0 MHz, f_{SMCLK} = f_{DCO} = 1 MHz

(4) Current for brownout, high-side supervisor (SVSH) normal mode included. Low-side supervisor (SVSL) and low-side monitor (SVM_L) disabled. High-side monitor (SVM_H) disabled. RAM retention enabled.

(5) Current for watchdog timer and RTC clocked by ACLK included. ACLK = low frequency crystal operation (XTS = 0, XT1DRIVE_x = 0). CPUOFF = 1, SCG0 = 0, SCG1 = 1, OSCOFF = 0 (LPM2), f_{ACLK} = 32768 Hz, f_{MCLK} = 0 MHz, f_{SMCLK} = f_{DCO} = 0 MHz, DCO setting = 1-MHz operation, DCO bias generator enabled.

(6) Current for watchdog timer and RTC clocked by low-frequency clock included. ACLK = low frequency crystal operation (XTS = 0, XT1DRIVE_x = 0).

CPUOFF = 1, SCG0 = 1, SCG1 = 1, OSCOFF = 0 (LPM3), f_{ACLK} = 32768 Hz, f_{MCLK} = f_{SMCLK} = f_{DCO} = 0 MHz

(7) Current for watchdog timer and RTC clocked by low-frequency clock included. ACLK = VLO.

CPUOFF = 1, SCG0 = 1, SCG1 = 1, OSCOFF = 0 (LPM3), f_{ACLK} = f_{VLO} , f_{MCLK} = f_{SMCLK} = f_{DCO} = 0 MHz

(8) CPUOFF = 1, SCG0 = 1, SCG1 = 1, OSCOFF = 1 (LPM4), f_{DCO} = f_{ACLK} = f_{MCLK} = f_{SMCLK} = 0 MHz

(9) f_{DCO} = f_{MCLK} = f_{SMCLK} = 0 MHz, f_{ACLK} = 32768 Hz, PMMREGOFF = 1, RTC active on AUXVCC3 supply

(10) f_{DCO} = f_{MCLK} = f_{SMCLK} = 0 MHz, f_{ACLK} = 0 Hz, PMMREGOFF = 1

5.6 Low-Power Mode With LCD Supply Currents (Into V_{CC}) Excluding External Current

over recommended ranges of supply voltage and operating free-air temperature (unless otherwise noted)⁽¹⁾⁽²⁾

PARAMETER	V_{CC}	PMMCOREVx	TEMPERATURE (T_A)						UNIT
			-40°C		25°C		85°C		
			TYP	MAX	TYP	MAX	TYP	MAX	
I_{LPM3} LCD, ext. bias	3 V	0	2.5		3.1		9.1	μ A	
		1	2.6		3.3		9.5		
		2	2.8		3.5		9.9		
		3	2.8		3.5	6.0	10.0 25.0		
I_{LPM3} LCD, int. bias	3 V	0	2.9		3.5		9.7	μ A	
		1	3.1		3.7		10.1		
		2	3.2		4.0		10.5		
		3	3.3		4.0	5.5	10.5 25.0		
I_{LPM3} LCD,CP	2.2 V	0	2.2		2.8		8.8	μ A	
		1	2.3		3.0		9.1		
		2	2.5		3.2		9.5		
	3 V	0	2.6		3.2		9.3	μ A	
		1	2.8		3.4		9.7		
		2	2.9		3.6		10.1		
		3	3.0		3.7		10.2		

- (1) All inputs are tied to 0 V or to V_{CC} . Outputs do not source or sink any current.
- (2) The currents are characterized with a Micro Crystal MS1 V-T1K crystal with a load capacitance of 12.5 pF. The internal and external load capacitance are chosen to closely match the required 12.5 pF.
- (3) Current for watchdog timer and RTC clocked by ACLK included. ACLK = low frequency crystal operation (XTS = 0, XT1DRIVEx = 0). CPUOFF = 1, SCG0 = 1, SCG1 = 1, OSCOFF = 0 (LPM3), f_{ACLK} = 32768 Hz, f_{MCLK} = f_{SMCLK} = f_{DCO} = 0 MHz. Current for brownout and high-side supervisor (SVSH) in normal mode included. Low-side supervisor (SVSL) and low-side monitor (SVM_L) disabled. High-side monitor (SVM_H) disabled. RAM retention enabled.
- (4) LCDMx = 11 (4-mux mode), LCDREXT = 1, LCDEXTBIAS = 1 (external biasing), LCD2B = 0 (1/3 bias), LCDCPEN = 0 (charge pump disabled), LCDSSEL = 0, LCDPREx = 101, LCDDIVx = 00011 (f_{LCD} = 32768 Hz / 32 / 4 = 256 Hz). Current through external resistors not included (voltage levels are supplied by test equipment). Even segments (S0, S2, ...) = 0, and odd segments (S1, S3, ...) = 1. No LCD panel load.
- (5) LCDMx = 11 (4-mux mode), LCDREXT = 0, LCDEXTBIAS = 0 (internal biasing), LCD2B = 0 (1/3 bias), LCDCPEN = 0 (charge pump disabled), LCDSSEL = 0, LCDPREx = 101, LCDDIVx = 00011 (f_{LCD} = 32768 Hz / 32 / 4 = 256 Hz). Even segments (S0, S2, ...) = 0, and odd segments (S1, S3, ...) = 1. No LCD panel load.
- (6) LCDMx = 11 (4-mux mode), LCDREXT = 0, LCDEXTBIAS = 0 (internal biasing), LCD2B = 0 (1/3 bias), LCDCPEN = 1 (charge pump enabled), VLCDx = 1000 (V_{LCD} = 3 V typical), LCDSSEL = 0, LCDPREx = 101, LCDDIVx = 00011 (f_{LCD} = 32768 Hz / 32 / 4 = 256 Hz). Even segments (S0, S2, ...) = 0, and odd segments (S1, S3, ...) = 1. No LCD panel load.

5.7 Thermal Resistance Characteristics

THERMAL METRIC ^{(1) (2)}			VALUE	UNIT
R _{θJA}	Junction-to-ambient thermal resistance, still air	LQFP 128 (PEU)	44.4	°C/W
		LQFP 100 (PZ)	42.9	
R _{θJC(TOP)}	Junction-to-case (top) thermal resistance	LQFP 128 (PEU)	10.5	°C/W
		LQFP 100 (PZ)	9.3	
R _{θJC(BOTTOM)}	Junction-to-case (bottom) thermal resistance	LQFP 128 (PEU)	N/A ⁽³⁾	°C/W
		LQFP 100 (PZ)	N/A	
R _{θJB}	Junction-to-board thermal resistance	LQFP 128 (PEU)	23.1	°C/W
		LQFP 100 (PZ)	20.6	
Ψ _{JT}	Junction-to-package-top thermal characterization parameter	LQFP 128 (PEU)	0.4	°C/W
		LQFP 100 (PZ)	0.3	
Ψ _{JB}	Junction-to-board thermal characterization parameter	LQFP 128 (PEU)	22.8	°C/W
		LQFP 100 (PZ)	20.3	

(1) For more information about traditional and new thermal metrics, see [Semiconductor and IC Package Thermal Metrics](#).

(2) These values are based on a JEDEC-defined 2S2P system (with the exception of the Theta JC [R_{θJC}] value, which is based on a JEDEC-defined 1S0P system) and will change based on environment as well as application. For more information, see these EIA/JEDEC standards:

- JESD51-2, *Integrated Circuits Thermal Test Method Environmental Conditions - Natural Convection (Still Air)*
- JESD51-3, *Low Effective Thermal Conductivity Test Board for Leaded Surface Mount Packages*
- JESD51-7, *High Effective Thermal Conductivity Test Board for Leaded Surface Mount Packages*
- JESD51-9, *Test Boards for Area Array Surface Mount Package Thermal Measurements*

(3) N/A = not applicable

5.8 Timing and Switching Characteristics

5.8.1 Reset Timing

Table 5-1 lists the device wake-up times.

Table 5-1. Wake-up Times From Low-Power Modes and Reset

over recommended ranges of supply voltage and operating free-air temperature (unless otherwise noted)

PARAMETER		TEST CONDITIONS	MIN	TYP	MAX	UNIT
t _{WAKE-UP-FAST}	Wake-up time from LPM2, LPM3, or LPM4 to active mode ⁽¹⁾	PMMCOREV = SVSMLRRL = n (where n = 0, 1, 2, or 3), SVSLFP = 1	f _{MCLK} ≥ 4.0 MHz		5	μs
			f _{MCLK} < 4.0 MHz		10	
t _{WAKE-UP-SLOW}	Wake-up time from LPM2, LPM3, or LPM4 to active mode ⁽²⁾⁽³⁾	PMMCOREV = SVSMLRRL = n (where n = 0, 1, 2, or 3), SVSLFP = 0		150	165	μs
t _{WAKE-UP-LPM4.5}	Wake-up time from LPM4.5 to active mode ⁽⁴⁾			2	3	ms
t _{WAKE-UP-RESET}	Wake-up time from $\overline{\text{RST}}$ or BOR event to active mode ⁽⁴⁾			2	3	ms

- (1) This value represents the time from the wake-up event to the first active edge of MCLK. The wake-up time depends on the performance mode of the low-side supervisor (SVS_L) and low-side monitor (SVM_L). t_{WAKE-UP-FAST} is possible with SVS_L and SVM_L in full performance mode or disabled. For specific register settings, see the *Low-Side SVS and SVM Control and Performance Mode Selection* section in the *Power Management Module and Supply Voltage Supervisor* chapter of the [MSP430x5xx and MSP430x6xx Family User's Guide](#).
- (2) This value represents the time from the wake-up event to the first active edge of MCLK. The wake-up time depends on the performance mode of the low-side supervisor (SVS_L) and low-side monitor (SVM_L). t_{WAKE-UP-SLOW} is set with SVS_L and SVM_L in normal mode (low current mode). For specific register settings, see the *Low-Side SVS and SVM Control and Performance Mode Selection* section in the *Power Management Module and Supply Voltage Supervisor* chapter of the [MSP430x5xx and MSP430x6xx Family User's Guide](#).
- (3) The wake-up times from LPM0 and LPM1 to AM are not specified. They are proportional to MCLK cycle time but are not affected by the performance mode settings as for LPM2, LPM3, and LPM4.
- (4) This value represents the time from the wake-up event to the reset vector execution.

5.8.2 Clock Specifications

Table 5-2 lists the characteristics of the crystal oscillator in low-frequency mode.

Table 5-2. Crystal Oscillator, XT1, Low-Frequency Mode⁽¹⁾

over recommended ranges of supply voltage and operating free-air temperature (unless otherwise noted)

PARAMETER	TEST CONDITIONS	V _{CC}	MIN	TYP	MAX	UNIT	
$\Delta I_{DVCC,LF}$	Differential XT1 oscillator crystal current consumption from lowest drive setting, LF mode	3 V		0.075		μA	
	$f_{OSC} = 32768$ Hz, XTS = 0, XT1BYPASS = 0, XT1DRIVE _x = 1, T _A = 25°C						
	$f_{OSC} = 32768$ Hz, XTS = 0, XT1BYPASS = 0, XT1DRIVE _x = 2, T _A = 25°C						
	$f_{OSC} = 32768$ Hz, XTS = 0, XT1BYPASS = 0, XT1DRIVE _x = 3, T _A = 25°C			0.290			
$f_{XT1,LF0}$	XT1 oscillator crystal frequency, LF mode			32768		Hz	
$f_{XT1,LF,SW}$	XT1 oscillator logic-level square-wave input frequency, LF mode		10	32.768	50	kHz	
OA_{LF}	Oscillation allowance for LF crystals ⁽⁴⁾			210		k Ω	
							XTS = 0, XT1BYPASS = 0, XT1DRIVE _x = 0, $f_{XT1,LF} = 32768$ Hz, C _{L,eff} = 6 pF
	XTS = 0, XT1BYPASS = 0, XT1DRIVE _x = 1, $f_{XT1,LF} = 32768$ Hz, C _{L,eff} = 12 pF			300			
$C_{L,eff}$	Integrated effective load capacitance, LF mode ⁽⁵⁾					pF	
							XTS = 0, XCAP _x = 0 ⁽⁶⁾
							XTS = 0, XCAP _x = 1
							XTS = 0, XCAP _x = 2
	XTS = 0, XCAP _x = 3			12.0			
	Duty cycle, LF mode			30%	70%		
$f_{Fault,LF}$	Oscillator fault frequency, LF mode ⁽⁷⁾			10	10000	Hz	
$t_{START,LF}$	Start-up time, LF mode	3 V		1000		ms	
							$f_{OSC} = 32768$ Hz, XTS = 0, XT1BYPASS = 0, XT1DRIVE _x = 0, T _A = 25°C, C _{L,eff} = 6 pF
	$f_{OSC} = 32768$ Hz, XTS = 0, XT1BYPASS = 0, XT1DRIVE _x = 3, T _A = 25°C, C _{L,eff} = 12 pF			500			

- (1) To improve EMI on the XT1 oscillator, the following guidelines should be observed.
 - Keep the trace between the device and the crystal as short as possible.
 - Design a good ground plane around the oscillator pins.
 - Prevent crosstalk from other clock or data lines into oscillator pins XIN and XOUT.
 - Avoid running PCB traces underneath or adjacent to the XIN and XOUT pins.
 - Use assembly materials and processes that avoid any parasitic load on the oscillator XIN and XOUT pins.
 - If conformal coating is used, make sure that it does not induce capacitive or resistive leakage between the oscillator pins.
- (2) When XT1BYPASS is set, XT1 circuits are automatically powered down. Input signal is a digital square wave with parametrics defined in the Schmitt-trigger Inputs section of this data sheet.
- (3) Maximum frequency of operation of the entire device cannot be exceeded.
- (4) Oscillation allowance is based on a safety factor of 5 for recommended crystals. The oscillation allowance is a function of the XT1DRIVE_x settings and the effective load. In general, comparable oscillator allowance can be achieved based on the following guidelines, but should be evaluated based on the actual crystal selected for the application:
 - For XT1DRIVE_x = 0, C_{L,eff} ≤ 6 pF.
 - For XT1DRIVE_x = 1, 6 pF ≤ C_{L,eff} ≤ 9 pF.
 - For XT1DRIVE_x = 2, 6 pF ≤ C_{L,eff} ≤ 10 pF.
 - For XT1DRIVE_x = 3, C_{L,eff} ≥ 6 pF.
- (5) Includes parasitic bond and package capacitance (approximately 2 pF per pin). Because the PCB adds additional capacitance, verify the correct load by measuring the ACLK frequency. For a correct setup, the effective load capacitance should always match the specification of the used crystal.
- (6) Requires external capacitors at both terminals. Values are specified by crystal manufacturers.
- (7) Frequencies below the MIN specification set the fault flag. Frequencies above the MAX specification do not set the fault flag. Frequencies in between might set the flag.
- (8) Measured with logic-level input frequency but also applies to operation with crystals.

Table 5-3 lists the characteristics of the VLO.

Table 5-3. Internal Very-Low-Power Low-Frequency Oscillator (VLO)

over recommended ranges of supply voltage and operating free-air temperature (unless otherwise noted)

PARAMETER		TEST CONDITIONS	V _{CC}	MIN	TYP	MAX	UNIT
f _{VLO}	VLO frequency	Measured at ACLK	1.8 V to 3.6 V	6	9.6	15	kHz
df _{VLO} /dT	VLO frequency temperature drift	Measured at ACLK	1.8 V to 3.6 V		0.5		%/°C
df _{VLO} /dV _{CC}	VLO frequency supply voltage drift	Measured at ACLK	1.8 V to 3.6 V		4		%/V
	Duty cycle	Measured at ACLK	1.8 V to 3.6 V	40%	50%	60%	

Table 5-4 lists the characteristics of the REFO.

Table 5-4. Internal Reference, Low-Frequency Oscillator (REFO)

over recommended ranges of supply voltage and operating free-air temperature (unless otherwise noted)

PARAMETER		TEST CONDITIONS	V _{CC}	MIN	TYP	MAX	UNIT
I _{REFO}	REFO oscillator current consumption	T _A = 25°C	1.8 V to 3.6 V		3		μA
f _{REFO}	REFO frequency calibrated	Measured at ACLK	1.8 V to 3.6 V		32768		Hz
	REFO absolute tolerance calibrated	Full temperature range	1.8 V to 3.6 V	-3.5%		+3.5%	
		T _A = 25°C	3 V	-1.5%		+1.5%	
df _{REFO} /dT	REFO frequency temperature drift	Measured at ACLK	1.8 V to 3.6 V		0.01		%/°C
df _{REFO} /dV _{CC}	REFO frequency supply voltage drift	Measured at ACLK	1.8 V to 3.6 V		1.0		%/V
	Duty cycle	Measured at ACLK	1.8 V to 3.6 V	40%	50%	60%	
t _{START}	REFO start-up time	40%/60% duty cycle	1.8 V to 3.6 V		25		μs

Table 5-5 lists the frequency characteristics of the DCO.

Table 5-5. DCO Frequency

over recommended ranges of supply voltage and operating free-air temperature (unless otherwise noted) (see Figure 5-2)

PARAMETER	TEST CONDITIONS	MIN	TYP	MAX	UNIT
$f_{DCO(0,0)}$	DCO frequency (0, 0) ⁽¹⁾	DCORSELx = 0, DCOx = 0, MODx = 0	0.07	0.20	MHz
$f_{DCO(0,31)}$	DCO frequency (0, 31) ⁽¹⁾	DCORSELx = 0, DCOx = 31, MODx = 0	0.70	1.70	MHz
$f_{DCO(1,0)}$	DCO frequency (1, 0) ⁽¹⁾	DCORSELx = 1, DCOx = 0, MODx = 0	0.15	0.36	MHz
$f_{DCO(1,31)}$	DCO frequency (1, 31) ⁽¹⁾	DCORSELx = 1, DCOx = 31, MODx = 0	1.47	3.45	MHz
$f_{DCO(2,0)}$	DCO frequency (2, 0) ⁽¹⁾	DCORSELx = 2, DCOx = 0, MODx = 0	0.32	0.75	MHz
$f_{DCO(2,31)}$	DCO frequency (2, 31) ⁽¹⁾	DCORSELx = 2, DCOx = 31, MODx = 0	3.17	7.38	MHz
$f_{DCO(3,0)}$	DCO frequency (3, 0) ⁽¹⁾	DCORSELx = 3, DCOx = 0, MODx = 0	0.64	1.51	MHz
$f_{DCO(3,31)}$	DCO frequency (3, 31) ⁽¹⁾	DCORSELx = 3, DCOx = 31, MODx = 0	6.07	14.0	MHz
$f_{DCO(4,0)}$	DCO frequency (4, 0) ⁽¹⁾	DCORSELx = 4, DCOx = 0, MODx = 0	1.3	3.2	MHz
$f_{DCO(4,31)}$	DCO frequency (4, 31) ⁽¹⁾	DCORSELx = 4, DCOx = 31, MODx = 0	12.3	28.2	MHz
$f_{DCO(5,0)}$	DCO frequency (5, 0) ⁽¹⁾	DCORSELx = 5, DCOx = 0, MODx = 0	2.5	6.0	MHz
$f_{DCO(5,31)}$	DCO frequency (5, 31) ⁽¹⁾	DCORSELx = 5, DCOx = 31, MODx = 0	23.7	54.1	MHz
$f_{DCO(6,0)}$	DCO frequency (6, 0) ⁽¹⁾	DCORSELx = 6, DCOx = 0, MODx = 0	4.6	10.7	MHz
$f_{DCO(6,31)}$	DCO frequency (6, 31) ⁽¹⁾	DCORSELx = 6, DCOx = 31, MODx = 0	39.0	88.0	MHz
$f_{DCO(7,0)}$	DCO frequency (7, 0) ⁽¹⁾	DCORSELx = 7, DCOx = 0, MODx = 0	8.5	19.6	MHz
$f_{DCO(7,31)}$	DCO frequency (7, 31) ⁽¹⁾	DCORSELx = 7, DCOx = 31, MODx = 0	60	135	MHz
$S_{DCORSEL}$	Frequency step between range DCORSEL and DCORSEL + 1	$S_{RSEL} = f_{DCO(DCORSEL+1,DCO)}/f_{DCO(DCORSEL,DCO)}$	1.2	2.3	ratio
S_{DCO}	Frequency step between tap DCO and DCO + 1	$S_{DCO} = f_{DCO(DCORSEL,DCO+1)}/f_{DCO(DCORSEL,DCO)}$	1.02	1.12	ratio
	Duty cycle	Measured at SMCLK	40%	50%	60%
df_{DCO}/dT	DCO frequency temperature drift	$f_{DCO} = 1 \text{ MHz}$	0.1		%/°C
df_{DCO}/dV_{CORE}	DCO frequency voltage drift	$f_{DCO} = 1 \text{ MHz}$	1.9		%/V

- (1) When selecting the proper DCO frequency range (DCORSELx), the target DCO frequency, f_{DCO} , should be set to reside within the range of $f_{DCO(n,0),MAX} \leq f_{DCO} \leq f_{DCO(n,31),MIN}$, where $f_{DCO(n,0),MAX}$ represents the maximum frequency specified for the DCO frequency, range n, tap 0 (DCOx = 0) and $f_{DCO(n,31),MIN}$ represents the minimum frequency specified for the DCO frequency, range n, tap 31 (DCOx = 31). This ensures that the target DCO frequency resides within the range selected. It should also be noted that if the actual f_{DCO} frequency for the selected range causes the FLL or the application to select tap 0 or 31, the DCO fault flag is set to report that the selected range is at its minimum or maximum tap setting.

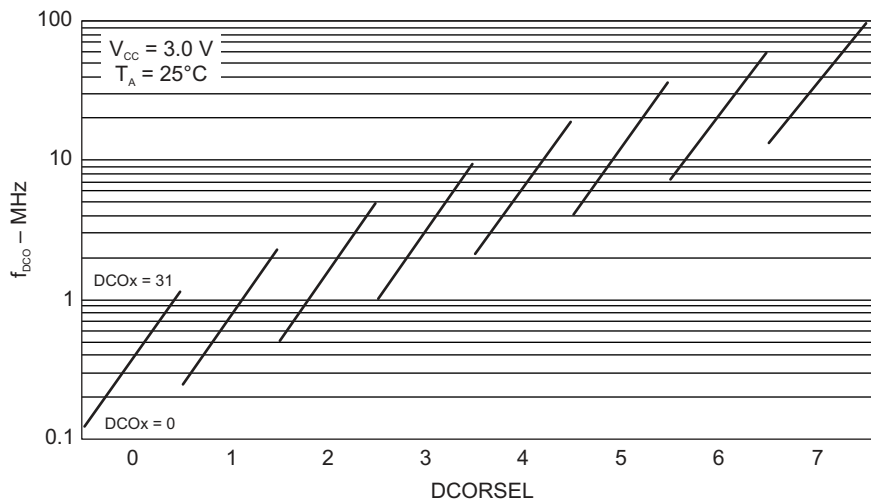

Figure 5-2. Typical DCO Frequency

5.9 Digital I/Os

Table 5-6 lists the input characteristics of the Schmitt-trigger GPIOs.

Table 5-6. Schmitt-Trigger Inputs – General-Purpose I/O

over recommended ranges of supply voltage and operating free-air temperature (unless otherwise noted)

PARAMETER		TEST CONDITIONS	V _{CC}	MIN	TYP	MAX	UNIT
V _{IT+}	Positive-going input threshold voltage		1.8 V	0.80		1.40	V
			3 V	1.50		2.10	
V _{IT-}	Negative-going input threshold voltage		1.8 V	0.45		1.00	V
			3 V	0.75		1.65	
V _{hys}	Input voltage hysteresis (V _{IT+} – V _{IT-})		1.8 V	0.3		0.85	V
			3 V	0.4		1.0	
R _{Pull}	Pullup or pulldown resistor	For pullup: V _{IN} = V _{SS} , For pulldown: V _{IN} = V _{CC}		20	35	50	kΩ
C _I	Input capacitance	V _{IN} = V _{SS} or V _{CC}			5		pF

Table 5-7 lists the input characteristics of the GPIOs.

Table 5-7. Inputs – Ports P1 and P2⁽¹⁾

over recommended ranges of supply voltage and operating free-air temperature (unless otherwise noted)

PARAMETER	TEST CONDITIONS	V _{CC}	MIN	MAX	UNIT
t _(int)	External interrupt timing ⁽²⁾ Port P1, P2: P1.x to P2.x, External trigger pulse duration to set interrupt flag	2.2 V, 3 V	20		ns

- (1) Some devices may contain additional ports with interrupts. See the block diagram and terminal function descriptions.
(2) An external signal sets the interrupt flag every time the minimum interrupt pulse duration t_(int) is met. It may be set by trigger signals shorter than t_(int).

Table 5-8 lists the leakage characteristics of the GPIOs.

Table 5-8. Leakage Current – General-Purpose I/O

over recommended ranges of supply voltage and operating free-air temperature (unless otherwise noted)

PARAMETER	TEST CONDITIONS	V _{CC}	MIN	MAX	UNIT
I _{Ikg(Px.y)}	High-impedance leakage current (⁽¹⁾ (²⁾)	1.8 V, 3 V	-50	+50	nA

- (1) The leakage current is measured with V_{SS} or V_{CC} applied to the corresponding pins, unless otherwise noted.
(2) The leakage of the digital port pins is measured individually. The port pin is selected for input and the pullup or pulldown resistor is disabled.

Table 5-9 lists the output characteristics of the GPIOs in full drive strength mode.

Table 5-9. Outputs – General-Purpose I/O (Full Drive Strength)

over recommended ranges of supply voltage and operating free-air temperature (unless otherwise noted) (see Section 5.9.2)

PARAMETER		TEST CONDITIONS	V _{CC}	MIN	MAX	UNIT
V _{OH}	High-level output voltage	I _(OHmax) = -3 mA ⁽¹⁾	1.8 V	1.55	1.80	V
		I _(OHmax) = -10 mA ⁽¹⁾		1.20	1.80	
		I _(OHmax) = -5 mA ⁽¹⁾	3 V	2.75	3.00	
		I _(OHmax) = -15 mA ⁽¹⁾		2.40	3.00	
V _{OL}	Low-level output voltage	I _(OLmax) = 3 mA ⁽²⁾	1.8 V	0.00	0.25	V
		I _(OLmax) = 10 mA ⁽³⁾		0.00	0.60	
		I _(OLmax) = 5 mA ⁽²⁾	3 V	0.00	0.25	
		I _(OLmax) = 15 mA ⁽³⁾		0.00	0.60	

- (1) The maximum total current, I_(OHmax), for all outputs combined should not exceed ±20 mA to hold the maximum voltage drop specified. See Section 5.3 for more details.
- (2) The maximum total current, I_(OLmax), for all outputs combined should not exceed ±48 mA to hold the maximum voltage drop specified.
- (3) The maximum total current, I_(OLmax), for all outputs combined should not exceed ±100 mA to hold the maximum voltage drop specified.

Table 5-10 lists the output characteristics of the GPIOs in reduced drive strength mode.

Table 5-10. Outputs – General-Purpose I/O (Reduced Drive Strength)

over recommended ranges of supply voltage and operating free-air temperature (unless otherwise noted)⁽¹⁾ (see Section 5.9.1)

PARAMETER		TEST CONDITIONS	V _{CC}	MIN	MAX	UNIT
V _{OH}	High-level output voltage	I _(OHmax) = -1 mA ⁽²⁾	1.8 V	1.55	1.80	V
		I _(OHmax) = -3 mA ⁽²⁾		1.20	1.80	
		I _(OHmax) = -2 mA ⁽²⁾	3 V	2.75	3.00	
		I _(OHmax) = -6 mA ⁽²⁾		2.40	3.00	
V _{OL}	Low-level output voltage	I _(OLmax) = 1 mA ⁽³⁾	1.8 V	0.00	0.25	V
		I _(OLmax) = 3 mA ⁽⁴⁾		0.00	0.60	
		I _(OLmax) = 2 mA ⁽³⁾	3 V	0.00	0.25	
		I _(OLmax) = 6 mA ⁽⁴⁾		0.00	0.60	

- (1) Selecting reduced drive strength may reduce EMI.
- (2) The maximum total current, I_(OHmax), for all outputs combined should not exceed ±20 mA to hold the maximum voltage drop specified. See Section 5.3 for more details.
- (3) The maximum total current, I_(OLmax), for all outputs combined, should not exceed ±48 mA to hold the maximum voltage drop specified.
- (4) The maximum total current, I_(OLmax), for all outputs combined, should not exceed ±100 mA to hold the maximum voltage drop specified.

Table 5-11 lists the output frequency of the GPIOs.

Table 5-11. Output Frequency – General-Purpose I/O

over recommended ranges of supply voltage and operating free-air temperature (unless otherwise noted)

PARAMETER		TEST CONDITIONS	MIN	MAX	UNIT
f _{Px,y}	Port output frequency (with load)	See ⁽¹⁾ ⁽²⁾	V _{CC} = 1.8 V, PMMCOREV _x = 0	16	MHz
			V _{CC} = 3 V, PMMCOREV _x = 3	25	
f _{Port_CLK}	Clock output frequency	ACLK SMCLK MCLK C _L = 20 pF ⁽²⁾	V _{CC} = 1.8 V, PMMCOREV _x = 0	16	MHz
			V _{CC} = 3 V, PMMCOREV _x = 3	25	

- (1) A resistive divider with 2 × R1 between V_{CC} and V_{SS} is used as load. The output is connected to the center tap of the divider. For full drive strength, R1 = 550 Ω. For reduced drive strength, R1 = 1.6 kΩ. C_L = 20 pF is connected to the output to V_{SS}.
- (2) The output voltage reaches at least 10% and 90% V_{CC} at the specified toggle frequency.

5.9.1 Typical Characteristics – Outputs, Reduced Drive Strength ($P_{xDS.y} = 0$)

over recommended ranges of supply voltage and operating free-air temperature (unless otherwise noted)

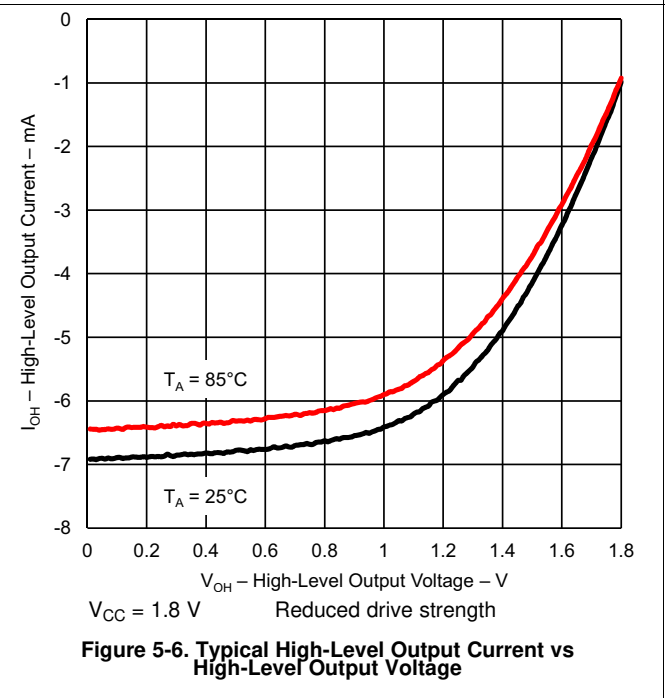
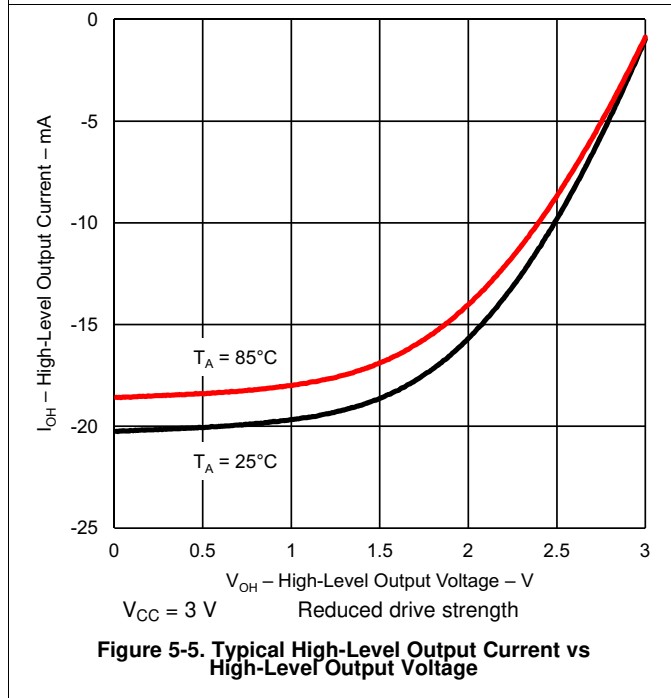
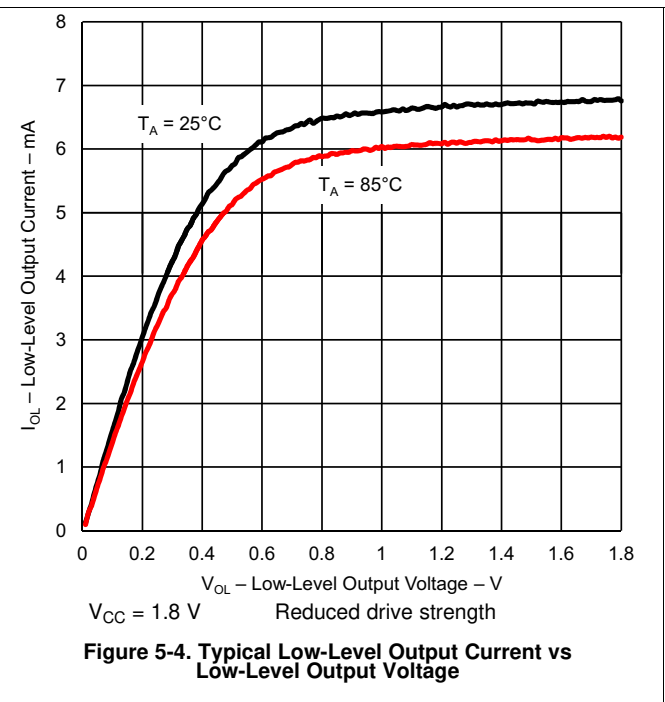
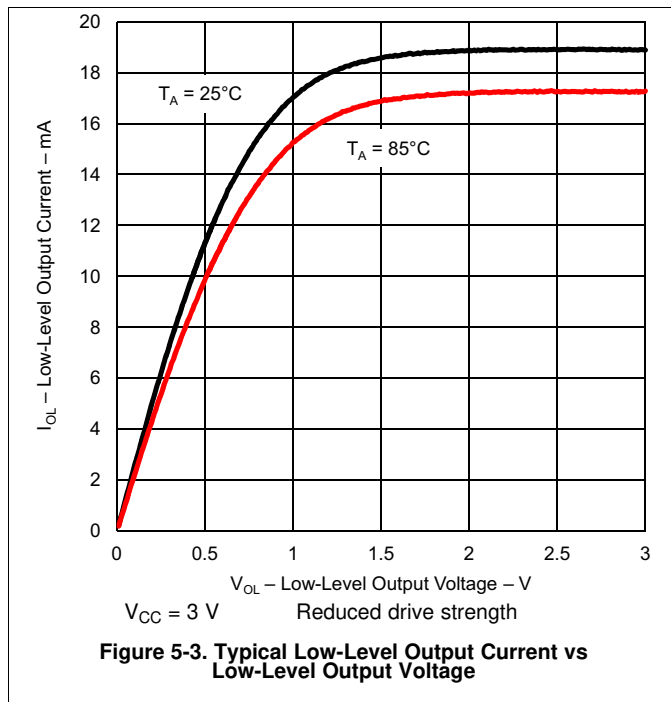

5.9.2 Typical Characteristics – Outputs, Full Drive Strength ($P_{xDS.y} = 1$)

over recommended ranges of supply voltage and operating free-air temperature (unless otherwise noted)

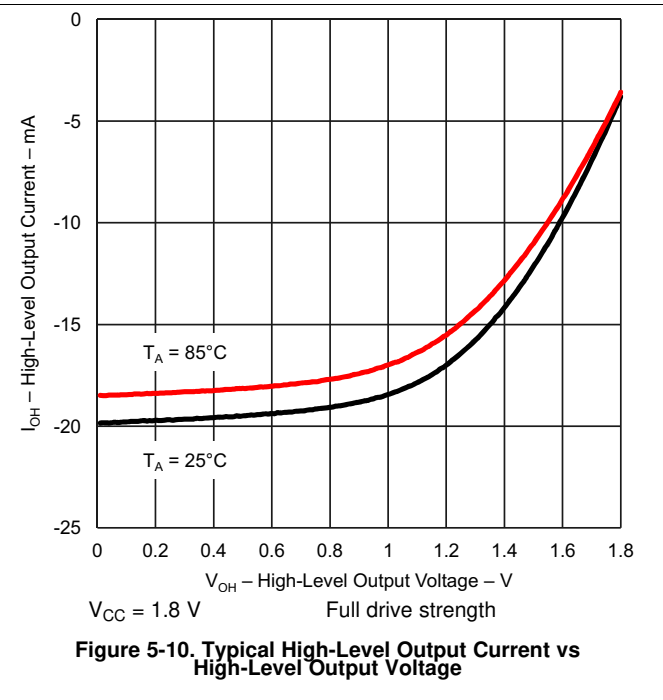
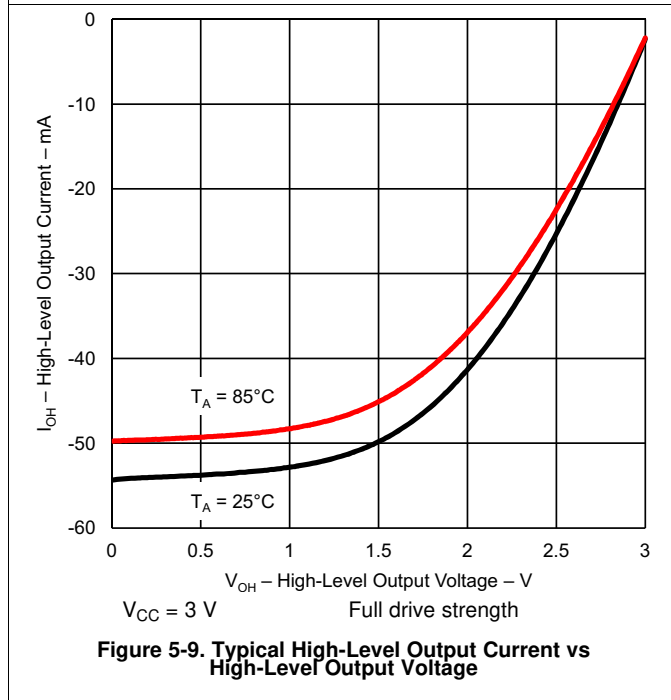
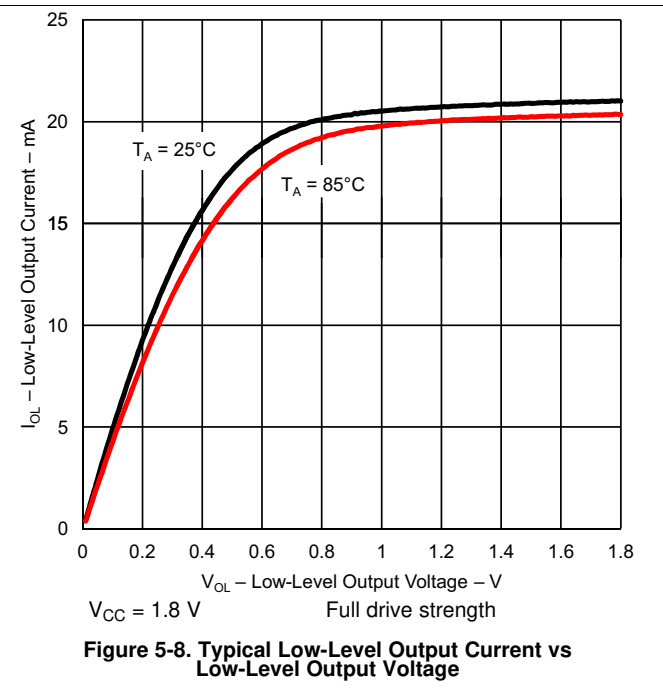
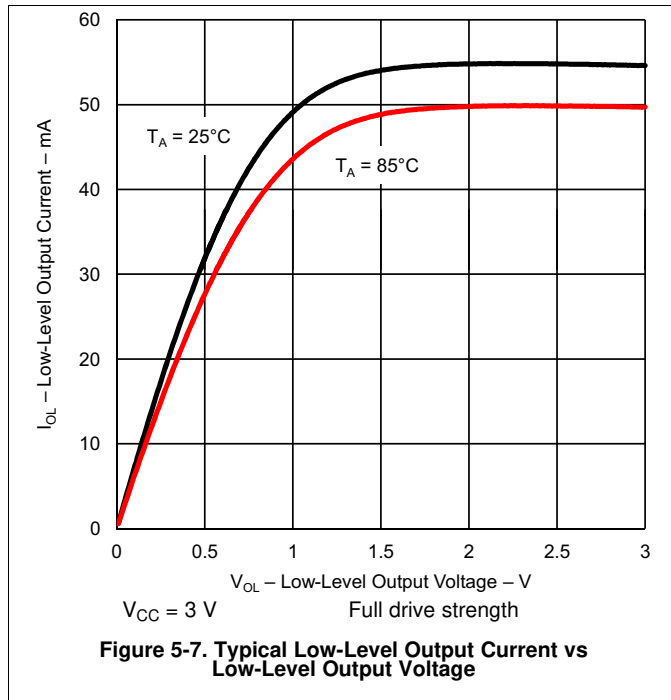

5.10 Power-Management Module (PMM)

Table 5-12 lists the characteristics of the BOR.

Table 5-12. PMM, Brownout Reset (BOR)

over recommended ranges of supply voltage and operating free-air temperature (unless otherwise noted)

PARAMETER		TEST CONDITIONS	MIN	TYP	MAX	UNIT
$V_{(DVCC_BOR_IT-)}$	BOR_H on voltage, DV_{CC} falling level	$ dDV_{CC}/dt < 3 \text{ V/s}$			1.45	V
$V_{(DVCC_BOR_IT+)}$	BOR_H off voltage, DV_{CC} rising level	$ dDV_{CC}/dt < 3 \text{ V/s}$	0.80	1.20	1.50	V
$V_{(DVCC_BOR_hys)}$	BOR_H hysteresis		50		250	mV
t_{RESET}	Pulse duration required at \overline{RST}/NMI pin to accept a reset		2			μs

Table 5-13 lists the core voltage characteristics of the PMM.

Table 5-13. PMM, Core Voltage

over recommended ranges of supply voltage and operating free-air temperature (unless otherwise noted)

PARAMETER		TEST CONDITIONS	MIN	TYP	MAX	UNIT
$V_{CORE3(AM)}$	Core voltage, active mode, $PMMCOREV = 3$	$2.4 \text{ V} \leq DV_{CC} \leq 3.6 \text{ V}$		1.91		V
$V_{CORE2(AM)}$	Core voltage, active mode, $PMMCOREV = 2$	$2.2 \text{ V} \leq DV_{CC} \leq 3.6 \text{ V}$		1.81		V
$V_{CORE1(AM)}$	Core voltage, active mode, $PMMCOREV = 1$	$2 \text{ V} \leq DV_{CC} \leq 3.6 \text{ V}$		1.61		V
$V_{CORE0(AM)}$	Core voltage, active mode, $PMMCOREV = 0$	$1.8 \text{ V} \leq DV_{CC} \leq 3.6 \text{ V}$		1.41		V
$V_{CORE3(LPM)}$	Core voltage, low-current mode, $PMMCOREV = 3$	$2.4 \text{ V} \leq DV_{CC} \leq 3.6 \text{ V}$		1.94		V
$V_{CORE2(LPM)}$	Core voltage, low-current mode, $PMMCOREV = 2$	$2.2 \text{ V} \leq DV_{CC} \leq 3.6 \text{ V}$		1.92		V
$V_{CORE1(LPM)}$	Core voltage, low-current mode, $PMMCOREV = 1$	$2 \text{ V} \leq DV_{CC} \leq 3.6 \text{ V}$		1.73		V
$V_{CORE0(LPM)}$	Core voltage, low-current mode, $PMMCOREV = 0$	$1.8 \text{ V} \leq DV_{CC} \leq 3.6 \text{ V}$		1.52		V

Table 5-14 lists the characteristics of the high-side SVS.

Table 5-14. PMM, SVS High Side

over recommended ranges of supply voltage and operating free-air temperature (unless otherwise noted)

PARAMETER		TEST CONDITIONS	MIN	TYP	MAX	UNIT
$I_{(SVSH)}$	SVS current consumption	$SVSHE = 0, DV_{CC} = 3.6 \text{ V}$		0		nA
		$SVSHE = 1, DV_{CC} = 3.6 \text{ V}, SVSHFP = 0$		200		
		$SVSHE = 1, DV_{CC} = 3.6 \text{ V}, SVSHFP = 1$		1.5		μA
$V_{(SVSH_IT-)}$	SVS_H on voltage level	$SVSHE = 1, SVSHRVL = 0$	1.60	1.65	1.75	V
		$SVSHE = 1, SVSHRVL = 1$	1.77	1.84	1.95	
		$SVSHE = 1, SVSHRVL = 2$	1.93	2.00	2.12	
		$SVSHE = 1, SVSHRVL = 3$	2.09	2.16	2.29	
$V_{(SVSH_IT+)}$	SVS_H off voltage level	$SVSHE = 1, SVSMHRRL = 0$	1.65	1.75	1.85	V
		$SVSHE = 1, SVSMHRRL = 1$	1.85	1.95	2.05	
		$SVSHE = 1, SVSMHRRL = 2$	2.05	2.15	2.25	
		$SVSHE = 1, SVSMHRRL = 3$	2.15	2.25	2.35	
		$SVSHE = 1, SVSMHRRL = 4$	2.30	2.40	2.55	
		$SVSHE = 1, SVSMHRRL = 5$	2.57	2.70	2.83	
		$SVSHE = 1, SVSMHRRL = 6$	2.90	3.05	3.20	
		$SVSHE = 1, SVSMHRRL = 7$	2.90	3.05	3.20	
$t_{pd(SVSH)}$	SVS_H propagation delay	$SVSHE = 1, dV_{DVCC}/dt = 10 \text{ mV}/\mu\text{s}, SVSHFP = 1$		2.5		μs
		$SVSHE = 1, dV_{DVCC}/dt = 1 \text{ mV}/\mu\text{s}, SVSHFP = 0$		20		
$t_{(SVSH)}$	SVS_H on or off delay time	$SVSHE = 0 \rightarrow 1, dV_{DVCC}/dt = 10 \text{ mV}/\mu\text{s}, SVSHFP = 1$		12.5		μs
		$SVSHE = 0 \rightarrow 1, dV_{DVCC}/dt = 1 \text{ mV}/\mu\text{s}, SVSHFP = 0$		100		
dV_{DVCC}/dt	DVCC rise time		0		1000	V/s

Table 5-15 lists the characteristics of the high-side SVM.

Table 5-15. PMM, SVM High Side

over recommended ranges of supply voltage and operating free-air temperature (unless otherwise noted)

PARAMETER	TEST CONDITIONS	MIN	TYP	MAX	UNIT
$I_{(SVMH)}$ SVM _H current consumption	SVMHE = 0, DV _{CC} = 3.6 V		0		nA
	SVMHE = 1, DV _{CC} = 3.6 V, SVMHFP = 0		200		
	SVMHE = 1, DV _{CC} = 3.6 V, SVMHFP = 1		1.5		μA
$V_{(SVMH)}$ SVM _H on or off voltage level ⁽¹⁾	SVMHE = 1, SVSMHRRRL = 0	1.63	1.73	1.83	V
	SVMHE = 1, SVSMHRRRL = 1	1.83	1.93	2.03	
	SVMHE = 1, SVSMHRRRL = 2	2.03	2.13	2.23	
	SVMHE = 1, SVSMHRRRL = 3	2.13	2.23	2.33	
	SVMHE = 1, SVSMHRRRL = 4	2.28	2.40	2.53	
	SVMHE = 1, SVSMHRRRL = 5	2.55	2.70	2.81	
	SVMHE = 1, SVSMHRRRL = 6	2.88	3.02	3.18	
	SVMHE = 1, SVSMHRRRL = 7	2.88	3.02	3.18	
	SVMHE = 1, SVMHOVPE = 1		3.77		
$t_{pd(SVMH)}$ SVM _H propagation delay	SVMHE = 1, dV _{DVCC} /dt = 10 mV/μs, SVMHFP = 1		2.5		μs
	SVMHE = 1, dV _{DVCC} /dt = 1 mV/μs, SVMHFP = 0		20		
$t_{t(SVMH)}$ SVM _H on or off delay time	SVMHE = 0 → 1, dV _{DVCC} /dt = 10 mV/μs, SVMHFP = 1		12.5		μs
	SVMHE = 0 → 1, dV _{DVCC} /dt = 1 mV/μs, SVMHFP = 0		100		

(1) The SVM_H settings available depend on the V_{CORE} (PMMCOREV_x) setting. See the *Power Management Module and Supply Voltage Supervisor* chapter in the *MSP430x5xx and MSP430x6xx Family User's Guide* on recommended settings and use.

Table 5-16 lists the characteristics of the low-side SVS.

Table 5-16. PMM, SVS Low Side

over recommended ranges of supply voltage and operating free-air temperature (unless otherwise noted)

PARAMETER	TEST CONDITIONS	MIN	TYP	MAX	UNIT
$I_{(SVSL)}$ SVS _L current consumption	SVSLE = 0, PMMCOREV = 2		0		nA
	SVSLE = 1, PMMCOREV = 2, SVSLFP = 0		200		
	SVSLE = 1, PMMCOREV = 2, SVSLFP = 1		1.5		μA
$t_{pd(SVSL)}$ SVS _L propagation delay	SVSLE = 1, dV _{CORE} /dt = 10 mV/μs, SVSLFP = 1		2.5		μs
	SVSLE = 1, dV _{CORE} /dt = 1 mV/μs, SVSLFP = 0		20		
$t_{t(SVSL)}$ SVS _L on or off delay time	SVSLE = 0 → 1, dV _{CORE} /dt = 10 mV/μs, SVSLFP = 1		12.5		μs
	SVSLE = 0 → 1, dV _{CORE} /dt = 1 mV/μs, SVSLFP = 0		100		

Table 5-17 lists the characteristics of the low-side SVM.

Table 5-17. PMM, SVM Low Side

over recommended ranges of supply voltage and operating free-air temperature (unless otherwise noted)

PARAMETER		TEST CONDITIONS	MIN	TYP	MAX	UNIT
$I_{(SVM_L)}$	SVM _L current consumption	SVMLE = 0, PMMCOREV = 2		0		nA
		SVMLE = 1, PMMCOREV = 2, SVMLFP = 0		200		
		SVMLE = 1, PMMCOREV = 2, SVMLFP = 1		1.5		μA
$t_{pd(SVM_L)}$	SVM _L propagation delay	SVMLE = 1, $dV_{CORE}/dt = 10 \text{ mV}/\mu\text{s}$, SVMLFP = 1		2.5		μs
		SVMLE = 1, $dV_{CORE}/dt = 1 \text{ mV}/\mu\text{s}$, SVMLFP = 0		20		
$t_{(SVM_L)}$	SVM _L on or off delay time	SVMLE = 0 → 1, $dV_{CORE}/dt = 10 \text{ mV}/\mu\text{s}$, SVMLFP = 1		12.5		μs
		SVMLE = 0 → 1, $dV_{CORE}/dt = 1 \text{ mV}/\mu\text{s}$, SVMLFP = 0		100		

5.11 Auxiliary Supplies

Table 5-18 lists the recommended operating conditions of the auxiliary supplies.

Table 5-18. Auxiliary Supplies, Recommended Operating Conditions

over operating free-air temperature range (unless otherwise noted)

		MIN	NOM	MAX	UNIT
V_{CC}	Supply voltage range for all supplies at pins DVCC, AVCC, AUXVCC1, AUXVCC2, AUXVCC3	1.8		3.6	V
V_{DSYS}	Digital system supply voltage range, $V_{DSYS} = V_{CC} - R_{ON} \times I_{LOAD}$	PMMCOREV _x = 0		3.6	V
		PMMCOREV _x = 1	2.0	3.6	
		PMMCOREV _x = 2	2.2	3.6	
		PMMCOREV _x = 3	2.4	3.6	
V_{ASYS}	Analog system supply voltage range, $V_{ASYS} = V_{CC} - R_{ON} \times I_{LOAD}$	See module specifications			V
T_A	Ambient temperature range	-40		85	°C
$T_{A,HTOL}$	Ambient temperature during HTOL (module should be functional during HTOL)			150	°C
$C_{VCC}, C_{AUX1/2}$	Recommended capacitor at pins DVCC, AVCC, AUXVCC1, AUXVCC2		4.7		μF
C_{VSY}	Recommended capacitor at pins VDSYS1, VDSYS2 and VASYS1, VASYS2		4.7		μF
C_{VCORE}	Recommended capacitance at pin V _{CORE}		0.47		μF
C_{AUX3}	Recommended capacitor at pin AUXVCC3		0.47		μF

Table 5-19 lists the current consumption of the backup subsystem.

Table 5-19. Auxiliary Supplies, AUXVCC3 (Backup Subsystem) Currents

over operating free-air temperature range (unless otherwise noted)

PARAMETER	TEST CONDITIONS	V_{CC}	T_A	MIN	MAX	UNIT
$I_{AUX3,RTCon}$	AUXVCC3 current with RTC enabled	3 V	25°C		0.86	μA
			85°C		1.2	
$I_{AUX3,RTCo}$	AUXVCC3 current with RTC disabled	3 V	25°C		120	nA
			85°C		220	

Table 5-20 lists the characteristics of the auxiliary supply monitor.

Table 5-20. Auxiliary Supplies, Auxiliary Supply Monitor

over operating free-air temperature range (unless otherwise noted)

PARAMETER		TEST CONDITIONS	MIN	TYP	MAX	UNIT
$I_{CC,Monitor}$	Average supply current for monitoring circuitry drawn from VDSYS	LOCKAUX = 0, AUXMRx = 0 AUX0MD = 0, AUX1MD = 0, AUX2MD = 1, VDSYS = DVCC, VASYS = AVCC, Current measured at VDSYS			1.10	μ A
$I_{Meas,Monitor}$	Average current drawn from monitored supply during measurement cycle	LOCKAUX = 0, AUXMRx = 0 AUX0MD = 0, AUX1MD = 0, AUX2MD = 1, VDSYS = DVCC, VASYS = AVCC, Current measured at AUXVCC1			0.13	μ A
$V_{Monitor}$	Auxiliary supply threshold level (same as high-side SVM)	General	V_{SVMH} (SVSMHRRL X = AUXLVLx) X - 5%	V_{SVMH} (SVSMHRRL X = AUXLVLx)	V_{SVMH} (SVSMHRRLx = AUXLVLx) X + 5%	V
		AUXLVLx = 0	1.65	1.75	1.85	
		AUXLVLx = 1	1.85	1.95	2.05	
		AUXLVLx = 2	2.05	2.15	2.25	
		AUXLVLx = 3	2.15	2.25	2.35	
		AUXLVLx = 4	2.30	2.40	2.55	
		AUXLVLx = 5	2.57	2.70	2.83	
		AUXLVLx = 6	2.90	3.00	3.20	
AUXLVLx = 7	2.90	3.00	3.20			

Table 5-21 lists the ON-resistance characteristics of the switches.

Table 5-21. Auxiliary Supplies, Switch ON-Resistance

over operating free-air temperature range (unless otherwise noted)

PARAMETER		TEST CONDITIONS	MIN	MAX	UNIT
$R_{ON,DVCC}$	ON-resistance of switch between DVCC and VDSYS	$I_{LOAD} = I_{CORE} + I_{IO} = 10\text{ mA} + 10\text{ mA} = 20\text{ mA}$		5	Ω
$R_{ON,DAUX1}$	ON-resistance of switch between AUXVCC1 and VDSYS	$I_{LOAD} = I_{CORE} + I_{IO} = 10\text{ mA} + 10\text{ mA} = 20\text{ mA}$		5	Ω
$R_{ON,DAUX2}$	ON-resistance of switch between AUXVCC2 and VDSYS	$I_{LOAD} = I_{CORE} + I_{IO} = 10\text{ mA} + 10\text{ mA} = 20\text{ mA}$		5	Ω
$R_{ON,AVCC}$	ON-resistance of switch between AVCC and VASYS	$I_{LOAD} = I_{Modules} = 10\text{ mA}$		5	Ω
$R_{ON,AAUX1}$	ON-resistance of switch between AUXVCC1 and VASYS	$I_{LOAD} = I_{Modules} = 5\text{ mA}$		20	Ω
$R_{ON,AAUX2}$	ON-resistance of switch between AUXVCC2 and VASYS	$I_{LOAD} = I_{Modules} = 5\text{ mA}$		20	Ω

Table 5-22 lists the switching times of the auxiliary supplies.

Table 5-22. Auxiliary Supplies, Switching Time

over operating free-air temperature range (unless otherwise noted)

PARAMETER		MIN	MAX	UNIT
t_{Switch}	Time from occurrence of trigger (SVM or software) to "new" supply connected to system supplies		100	ns
t_{Recover}	"Recovery time" after a switch over takes place. During this time, another switch cannot occur.	170	480	μs

Table 5-23 lists the leakage characteristics of the switch.

Table 5-23. Auxiliary Supplies, Switch Leakage

over operating free-air temperature range (unless otherwise noted)

PARAMETER	TEST CONDITIONS	MIN	TYP	MAX	UNIT
$I_{\text{SW,Lkg}}$	Current into DVCC, AVCC, AUXVCC1, or AUXVCC2 if not selected	Per supply (but not the highest supply)			
			75	250	nA
I_{Vmax}	Current drawn from highest supply		500	700	nA

Table 5-24 lists the characteristics of the auxiliary supplies to the ADC.

Table 5-24. Auxiliary Supplies, Auxiliary Supplies to ADC10_A

over operating free-air temperature range (unless otherwise noted)

PARAMETER		TEST CONDITIONS		V_{CC}	MIN	TYP	MAX	UNIT
V_3	Supply voltage divider $V_3 = V_{\text{Supply}} / 3$			1.8 V	0.57	0.6	0.63	V
				3 V	0.95	1.0	1.05	
				3.6 V	1.14	1.2	1.26	
R_{V3}	Load resistance	AUXADCRx = 0					15	k Ω
		AUXADCRx = 1					1.5	
		AUXADCRx = 2					0.6	
$t_{\text{Sample,V3}}$	Sampling time required if V_3 is selected	Error of conversion result ≤ 1 LSB	AUXADCRx = 0		1000			ns
			AUXADCRx = 1		1000			
			AUXADCRx = 2		1000			

Table 5-25 lists the characteristics of the charge limiting resistor.

Table 5-25. Auxiliary Supplies, Charge Limiting Resistor

over operating free-air temperature range (unless otherwise noted)

PARAMETER		TEST CONDITIONS	V_{CC}	MIN	TYP	MAX	UNIT
R_{CHARGE}	Charge limiting resistor	AUXCHCx = 1	3 V			5	k Ω
		AUXCHCx = 2				10	
		AUXCHCx = 3				20	

5.12 Timer_A

Table 5-26 lists the characteristics of the Timer_A.

Table 5-26. Timer_A

over recommended ranges of supply voltage and operating free-air temperature (unless otherwise noted)

PARAMETER		TEST CONDITIONS	V _{CC}	MIN	MAX	UNIT
f _{TA}	Timer_A input clock frequency	Internal: SMCLK or ACLK, External: TACLK, Duty cycle = 50% ±10%	1.8 V, 3 V		25	MHz
t _{TA,cap}	Timer_A capture timing	All capture inputs, Minimum pulse duration required for capture	1.8 V, 3 V	20		ns

5.13 eUSCI

Table 5-27 lists the supported clock frequencies of the eUSCI in UART mode.

Table 5-27. eUSCI (UART Mode) Clock Frequency

PARAMETER		TEST CONDITIONS	MIN	MAX	UNIT
f _{eUSCI}	eUSCI input clock frequency	Internal: SMCLK or ACLK, External: UCLK, Duty cycle = 50% ±10%		f _{SYSTEM}	MHz
f _{BITCLK}	BITCLK clock frequency (equals baud rate in MBaud)			5	MHz

Table 5-28 lists the switching characteristics of the eUSCI in UART mode.

Table 5-28. eUSCI (UART Mode) Switching Characteristics

over recommended ranges of supply voltage and operating free-air temperature (unless otherwise noted)

PARAMETER		TEST CONDITIONS	V _{CC}	MIN	TYP	MAX	UNIT
t _t	UART receive deglitch time ⁽¹⁾	UCGLITx = 0	2 V, 3 V	10	15	25	ns
		UCGLITx = 1		30	50	85	
		UCGLITx = 2		50	80	150	
		UCGLITx = 3		70	120	200	

- (1) Pulses on the UART receive input (UCxRX) shorter than the UART receive deglitch time are suppressed. To make sure that pulses are correctly recognized, their duration should exceed the maximum specification of the deglitch time.

Table 5-29 lists the supported clock frequencies of the eUSCI in SPI master mode.

Table 5-29. eUSCI (SPI Master Mode) Clock Frequency

PARAMETER		TEST CONDITIONS	MIN	MAX	UNIT
f_{eUSCI}	eUSCI input clock frequency	Internal: SMCLK or ACLK, Duty cycle = 50% ±10%		f_{SYSTEM}	MHz

Table 5-30 lists the switching characteristics of the eUSCI in SPI master mode.

Table 5-30. eUSCI (SPI Master Mode) Switching Characteristics

over recommended ranges of supply voltage and operating free-air temperature (unless otherwise noted)⁽¹⁾

PARAMETER		TEST CONDITIONS	V _{CC}	MIN	MAX	UNIT
$t_{STE,LEAD}$	STE lead time, STE low to clock	UCSTEM = 0, UCMODEx = 01 or 10	2 V, 3 V	150		ns
		UCSTEM = 1, UCMODEx = 01 or 10		150		
$t_{STE,LAG}$	STE lag time, Last clock to STE high	UCSTEM = 0, UCMODEx = 01 or 10	2 V, 3 V	200		ns
		UCSTEM = 1, UCMODEx = 01 or 10		200		
$t_{STE,ACC}$	STE access time, STE low to SIMO data out	UCSTEM = 0, UCMODEx = 01 or 10	2 V	50		ns
			3 V	30		
		UCSTEM = 1, UCMODEx = 01 or 10	2 V	50		
			3 V	30		
$t_{STE,DIS}$	STE disable time, STE high to SIMO high impedance	UCSTEM = 0, UCMODEx = 01 or 10	2 V	40		ns
			3 V	25		
		UCSTEM = 1, UCMODEx = 01 or 10	2 V	40		
			3 V	25		
$t_{SU,MI}$	SOMI input data setup time		2 V	50		ns
			3 V	30		
$t_{HD,MI}$	SOMI input data hold time		2 V	0		ns
			3 V	0		
$t_{VALID,MO}$	SIMO output data valid time ⁽²⁾	UCLK edge to SIMO valid, C _L = 20 pF	2 V	9		ns
			3 V	5		
$t_{HD,MO}$	SIMO output data hold time ⁽³⁾	C _L = 20 pF	2 V	0		ns
			3 V	0		

- $f_{UCxCLK} = 1/2t_{LO/HI}$ with $t_{LO/HI} = \max(t_{VALID,MO}(eUSCI) + t_{SU,SI}(Slave), t_{SU,MI}(eUSCI) + t_{VALID,SO}(Slave))$
For the slave parameters $t_{SU,SI}(Slave)$ and $t_{VALID,SO}(Slave)$, see the SPI parameters of the attached slave.
- Specifies the time to drive the next valid data to the SIMO output after the output changing UCLK clock edge. See the timing diagrams in Figure 5-11 and Figure 5-12.
- Specifies how long data on the SIMO output is valid after the output changing UCLK clock edge. Negative values indicate that the data on the SIMO output can become invalid before the output changing clock edge observed on UCLK. See the timing diagrams in Figure 5-11 and Figure 5-12.

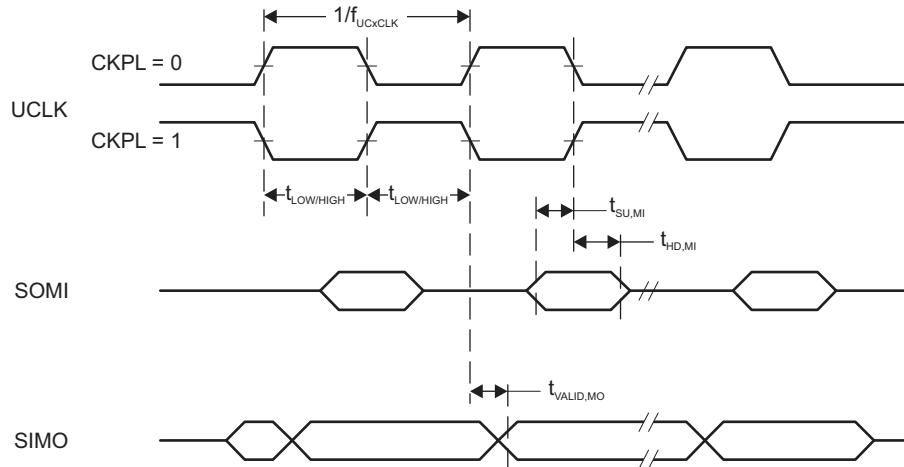

Figure 5-11. SPI Master Mode, CKPH = 0

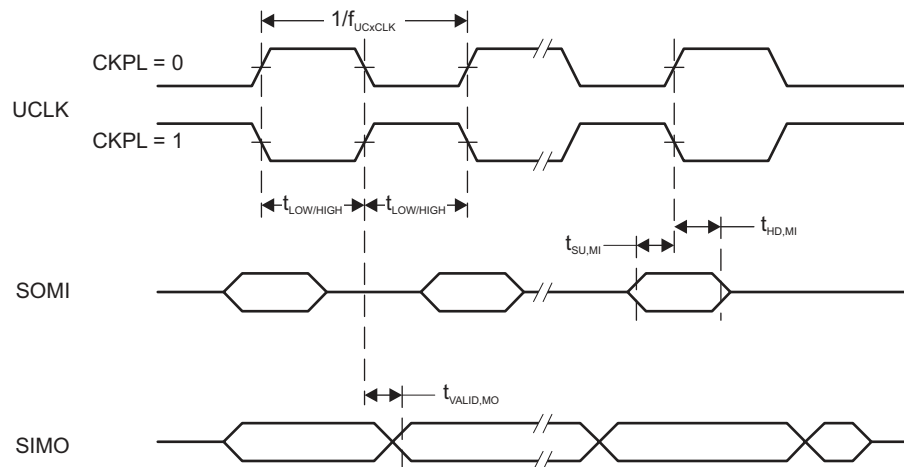

Figure 5-12. SPI Master Mode, CKPH = 1

Table 5-31 lists the characteristics of the eUSCI in SPI slave mode.

Table 5-31. eUSCI (SPI Slave Mode)

over recommended ranges of supply voltage and operating free-air temperature (unless otherwise noted)⁽¹⁾

PARAMETER		TEST CONDITIONS	V _{CC}	MIN	TYP	MAX	UNIT
t _{STE,LEAD}	STE lead time, STE low to clock		2 V	4			ns
			3 V	3			
t _{STE,LAG}	STE lag time, Last clock to STE high		2 V	0			ns
			3 V	0			
t _{STE,ACC}	STE access time, STE low to SOMI data out		2 V			46	ns
			3 V			24	
t _{STE,DIS}	STE disable time, STE high to SOMI high impedance		2 V			38	ns
			3 V			25	
t _{SU,SI}	SIMO input data setup time		2 V	2			ns
			3 V	1			
t _{HD,SI}	SIMO input data hold time		2 V	2			ns
			3 V	2			
t _{VALID,SO}	SOMI output data valid time ⁽²⁾	UCLK edge to SOMI valid, C _L = 20 pF	2 V			55	ns
			3 V			32	
t _{HD,SO}	SOMI output data hold time ⁽³⁾	C _L = 20 pF	2 V	24			ns
			3 V	16			

- (1) $f_{UCxCLK} = 1/2t_{LO/HI}$ with $t_{LO/HI} \geq \max(t_{VALID,MO(Master)} + t_{SU,SI(eUSCI)}, t_{SU,MI(Master)} + t_{VALID,SO(eUSCI)})$
For the master parameters $t_{SU,MI(Master)}$ and $t_{VALID,MO(Master)}$, see the SPI parameters of the attached master.
- (2) Specifies the time to drive the next valid data to the SOMI output after the output changing UCLK clock edge. See the timing diagrams in Figure 5-13 and Figure 5-14.
- (3) Specifies how long data on the SOMI output is valid after the output changing UCLK clock edge. See the timing diagrams in Figure 5-13 and Figure 5-14.

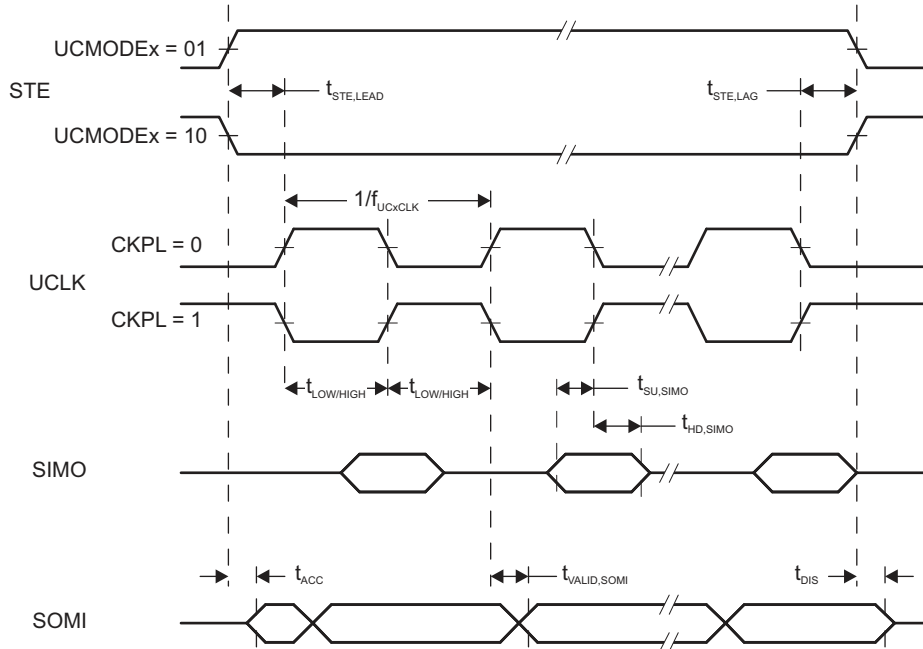

Figure 5-13. SPI Slave Mode, CKPH = 0

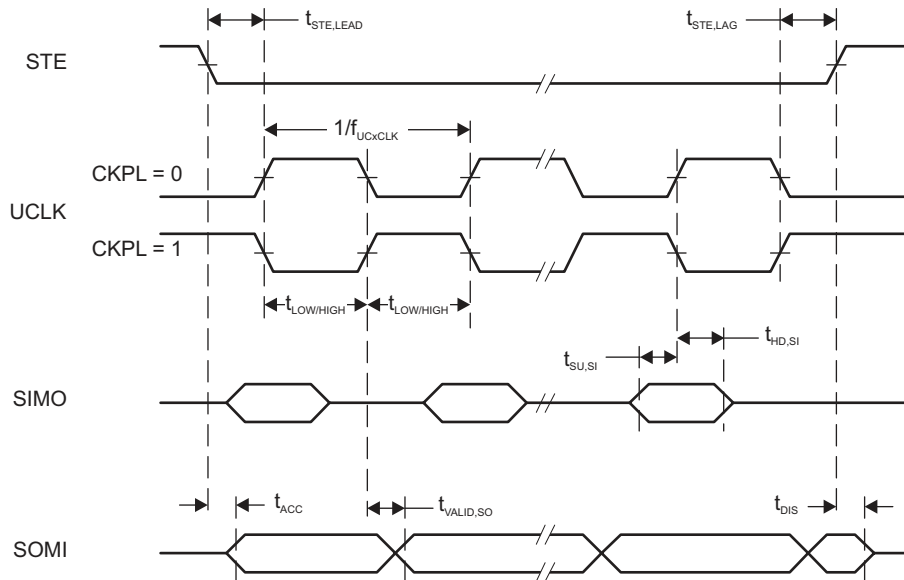

Figure 5-14. SPI Slave Mode, CKPH = 1

Table 5-32 lists the characteristics of the eUSCI in I²C mode.

Table 5-32. eUSCI (I²C Mode) Switching Characteristics

over recommended ranges of supply voltage and operating free-air temperature (unless otherwise noted) (see Figure 5-15)

PARAMETER	TEST CONDITIONS	V _{CC}	MIN	TYP	MAX	UNIT
f _{eUSCI}	eUSCI input clock frequency			f _{SYSTEM}		MHz
f _{SCL}	SCL clock frequency	2 V, 3 V	0		400	kHz
t _{HD,STA}	Hold time (repeated) START	f _{SCL} = 100 kHz f _{SCL} > 100 kHz	2 V, 3 V	5.1 1.5		μs
t _{SU,STA}	Setup time for a repeated START	f _{SCL} = 100 kHz f _{SCL} > 100 kHz	2 V, 3 V	5.1 1.4		μs
t _{HD,DAT}	Data hold time		2 V, 3 V	0.4		μs
t _{SU,DAT}	Data setup time	f _{SCL} = 100 kHz f _{SCL} > 100 kHz	2 V, 3 V	5.0 1.3		μs
t _{SU,STO}	Setup time for STOP	f _{SCL} = 100 kHz f _{SCL} > 100 kHz	2 V, 3 V	5.2 1.7		μs
t _{SP}	Pulse duration of spikes suppressed by input filter	UCGLITx = 0 UCGLITx = 1 UCGLITx = 2 UCGLITx = 3	2 V, 3 V	75 35 30 20	220 120 60 35	ns
t _{TIMEOUT}	Clock low time-out	UCCLTOx = 1 UCCLTOx = 2 UCCLTOx = 3	2 V, 3 V	30 33 37		ms

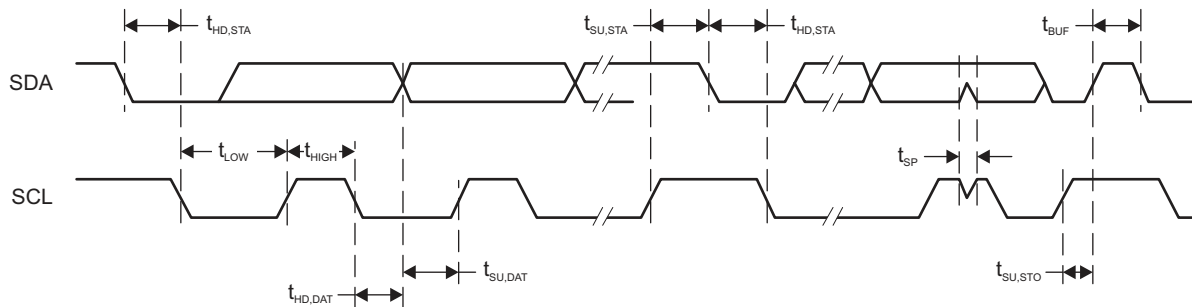

Figure 5-15. I²C Mode Timing

5.14 RTC Tamper Detect Pin

Table 5-33 lists the input characteristics of the tamper detect pin.

Table 5-33. Schmitt-Trigger Inputs, RTC Tamper Detect Pin

over recommended ranges of supply voltage and operating free-air temperature (unless otherwise noted)

PARAMETER	TEST CONDITIONS	AUXVCC3	MIN	TYP	MAX	UNIT
V _{IT+} Positive-going input threshold voltage		1.8 V	0.80		1.40	V
		3 V	1.50		2.10	
V _{IT-} Negative-going input threshold voltage		1.8 V	0.45		1.00	V
		3 V	0.75		1.65	
V _{hys} Input voltage hysteresis (V _{IT+} – V _{IT-})		1.8 V	0.3		0.85	V
		3 V	0.4		1.0	
R _{Pull} Pullup or pulldown resistor	For pullup: V _{IN} = V _{SS} For pulldown: V _{IN} = AUXVCC3		20	35	50	kΩ
C _I Input capacitance	V _{IN} = V _{SS} or AUXVCC3			5		pF

Table 5-34 lists the input requirements of the tamper detect pin.

Table 5-34. Inputs, RTC Tamper Detect Pin⁽¹⁾

over recommended ranges of supply voltage and operating free-air temperature (unless otherwise noted)

PARAMETER	TEST CONDITIONS	AUXVCC3	MIN	MAX	UNIT
t _(int) External interrupt timing ⁽²⁾	Port P1, P2: P1.x to P2.x, External trigger pulse duration to set interrupt flag	2.2 V, 3 V	20		ns

- (1) Some devices may contain additional ports with interrupts. See the block diagram and terminal function descriptions.
 (2) An external signal sets the interrupt flag every time the minimum interrupt pulse duration t_(int) is met. It may be set by trigger signals shorter than t_(int).

Table 5-35 lists the leakage current of the tamper detect pin.

Table 5-35. Leakage Current, RTC Tamper Detect Pin

over recommended ranges of supply voltage and operating free-air temperature (unless otherwise noted)

PARAMETER	TEST CONDITIONS	AUXVCC3	MIN	MAX	UNIT
I _{lkg(Px.y)} High-impedance leakage current	See ⁽¹⁾ ⁽²⁾	1.8 V, 3 V	-50	+50	nA

- (1) The leakage current is measured with V_{SS} or V_{CC} applied to the corresponding pins, unless otherwise noted.
 (2) The leakage of the digital port pins is measured individually. The port pin is selected for input and the pullup or pulldown resistor is disabled.

Table 5-36 lists the output characteristics of the tamper detect pin.

Table 5-36. Outputs, RTC Tamper Detect Pin

over recommended ranges of supply voltage and operating free-air temperature (unless otherwise noted)

PARAMETER	TEST CONDITIONS	AUXVCC3	MIN	MAX	UNIT
V _{OH} High-level output voltage	I _(OHmax) = -100 μA ⁽¹⁾	1.8 V	1.50	1.80	V
	I _(OHmax) = -200 μA ⁽¹⁾		1.20	1.80	
	I _(OHmax) = -100 μA ⁽¹⁾	3 V	2.70	3.00	
	I _(OHmax) = -200 μA ⁽¹⁾		2.40	3.00	
V _{OL} Low-level output voltage	I _(OLmax) = 100 μA ⁽²⁾	1.8 V	0.00	0.25	V
	I _(OLmax) = 200 μA ⁽²⁾		0.00	0.60	
	I _(OLmax) = 100 μA ⁽²⁾	3 V	0.00	0.25	
	I _(OLmax) = 200 μA ⁽²⁾		0.00	0.60	

- (1) The maximum total current, I_(OHmax), for all outputs combined should not exceed ±20 mA to hold the maximum voltage drop specified. See Section 5.3 for more details.
 (2) The maximum total current, I_(OLmax), for all outputs combined should not exceed ±20 mA to hold the maximum voltage drop specified. See Section 5.3 for more details.

5.15 LCD_C

Table 5-37 lists the operating conditions of the LCD controller.

Table 5-37. LCD_C, Operating Conditions

PARAMETER	TEST CONDITIONS	MIN	NOM	MAX	UNIT	
$V_{CC,LCD_C,CP\ en,3.6}$	Supply voltage range, charge pump enabled, $V_{LCD} \leq 3.6\text{ V}$	LCDPEN = 1, $0000 < VLC Dx \leq 1111$ (charge pump enabled, $V_{LCD} \leq 3.6\text{ V}$)		2.2	3.6	V
$V_{CC,LCD_C,CP\ en,3.3}$	Supply voltage range, charge pump enabled, $V_{LCD} \leq 3.3\text{ V}$	LCDPEN = 1, $0000 < VLC Dx \leq 1100$ (charge pump enabled, $V_{LCD} \leq 3.3\text{ V}$)		2.0	3.6	V
$V_{CC,LCD_C,int.\ bias}$	Supply voltage range, internal biasing, charge pump disabled	LCDPEN = 0, VLCDEXT = 0		2.4	3.6	V
$V_{CC,LCD_C,ext.\ bias}$	Supply voltage range, external biasing, charge pump disabled	LCDPEN = 0, VLCDEXT = 0		2.4	3.6	V
$V_{CC,LCD_C,VLCDEXT}$	Supply voltage range, external LCD voltage, internal or external biasing, charge pump disabled	LCDPEN = 0, VLCDEXT = 1		2.0	3.6	V
$V_{LDCAP/R33}$	External LCD voltage at LDCAP/R33, internal or external biasing, charge pump disabled	LCDPEN = 0, VLCDEXT = 1		2.4	3.6	V
C_{LDCAP}	Capacitor on LDCAP when charge pump enabled	LCDPEN = 1, $VLC Dx > 0000$ (charge pump enabled)		4.7	4.7	10 μF
f_{LCD}	LCD frequency range	$f_{FRAME} = 1/(2 \times \text{mux}) \times f_{LCD}$ with mux = 1 (static) to 8		0	1024	Hz
$f_{FRAME,4mux}$	LCD frame frequency range	$f_{FRAME,4mux}(\text{MAX}) = 1/(2 \times 4) \times f_{LCD}(\text{MAX})$ $f_{LCD}(\text{MAX}) = 1/(2 \times 4) \times 1024\text{ Hz}$			128	Hz
$f_{FRAME,8mux}$	LCD frame frequency range	$f_{FRAME,8mux}(\text{MAX}) = 1/(2 \times 4) \times f_{LCD}(\text{MAX})$ $f_{LCD}(\text{MAX}) = 1/(2 \times 8) \times 1024\text{ Hz}$			64	Hz
$f_{ACLK,in}$	ACLK input frequency range	30	32	40	kHz	
C_{Panel}	Panel capacitance	100-Hz frame frequency			10000	pF
V_{R33}	Analog input voltage at R33	LCDPEN = 0, VLCDEXT = 1		2.4	$V_{CC} + 0.2$	V
$V_{R23,1/3bias}$	Analog input voltage at R23	LCDREXT = 1, LCDEXTBIAS = 1, LCD2B = 0		V_{R13}	$V_{R33} + \frac{2}{3} \times (V_{R33} - V_{R03})$	V_{R33} V
$V_{R13,1/3bias}$	Analog input voltage at R13 with 1/3 biasing	LCDREXT = 1, LCDEXTBIAS = 1, LCD2B = 0		V_{R03}	$V_{R03} + \frac{1}{3} \times (V_{R33} - V_{R03})$	V_{R23} V
$V_{R13,1/2bias}$	Analog input voltage at R13 with 1/2 biasing	LCDREXT = 1, LCDEXTBIAS = 1, LCD2B = 1		V_{R03}	$V_{R03} + \frac{1}{2} \times (V_{R33} - V_{R03})$	V_{R33} V
V_{R03}	Analog input voltage at R03	R03EXT = 1		V_{SS}		V
$V_{LCD} - V_{R03}$	Voltage difference between V_{LCD} and R03	LCDPEN = 0, R03EXT = 1		2.4	$V_{CC} + 0.2$	V
$V_{LCDREF/R13}$	External LCD reference voltage applied at LCDREF/R13	VLCDFREFx = 01		0.8	1.2	1.5 V

Table 5-38 lists the characteristics of the LCD controller.

Table 5-38. LCD_C, Electrical Characteristics

over operating free-air temperature range (unless otherwise noted)

PARAMETER		TEST CONDITIONS	V _{CC}	MIN	TYP	MAX	UNIT
V _{LCD}	LCD voltage	VLCDx = 0000, VLCDxEXT = 0	2.4 V to 3.6 V		V _{CC}		V
		LCDCPEN = 1, VLCDx = 0001	2 V to 3.6 V		2.60		
		LCDCPEN = 1, VLCDx = 0010	2 V to 3.6 V		2.66		
		LCDCPEN = 1, VLCDx = 0011	2 V to 3.6 V		2.72		
		LCDCPEN = 1, VLCDx = 0100	2 V to 3.6 V		2.78		
		LCDCPEN = 1, VLCDx = 0101	2 V to 3.6 V		2.84		
		LCDCPEN = 1, VLCDx = 0110	2 V to 3.6 V		2.90		
		LCDCPEN = 1, VLCDx = 0111	2 V to 3.6 V		2.96		
		LCDCPEN = 1, VLCDx = 1000	2 V to 3.6 V		3.02		
		LCDCPEN = 1, VLCDx = 1001	2 V to 3.6 V		3.08		
		LCDCPEN = 1, VLCDx = 1010	2 V to 3.6 V		3.14		
		LCDCPEN = 1, VLCDx = 1011	2 V to 3.6 V		3.20		
		LCDCPEN = 1, VLCDx = 1100	2 V to 3.6 V		3.26		
		LCDCPEN = 1, VLCDx = 1101	2.2 V to 3.6 V		3.32		
		LCDCPEN = 1, VLCDx = 1110	2.2 V to 3.6 V		3.38		
LCDCPEN = 1, VLCDx = 1111	2.2 V to 3.6 V		3.50	3.72			
I _{CC,Peak,CP}	Peak supply currents due to charge pump activities	LCDCPEN = 1, VLCDx = 1111	2.2 V		200		μA
t _{LCD,CP,on}	Time to charge C _{LCD} when discharged	C _{LCD} = 4.7 μF, LCDCPEN = 0→1, VLCDx = 1111	2.2 V		100	500	ms
I _{CP,Load}	Maximum charge pump load current	LCDCPEN = 1, VLCDx = 1111	2.2 V	50			μA
R _{LCD,Seg}	LCD driver output impedance, segment lines	LCDCPEN = 1, VLCDx = 1000, I _{LOAD} = ±10 μA	2.2 V			10	kΩ
R _{LCD,COM}	LCD driver output impedance, common lines	LCDCPEN = 1, VLCDx = 1000, I _{LOAD} = ±10 μA	2.2 V			10	kΩ

5.16 SD24_B

Table 5-39 lists the operating conditions of the SD24_B.

Table 5-39. SD24_B, Power Supply and Operating Conditions

			MIN	TYP	MAX	UNIT
V_{CC}	Analog supply voltage	$V_{CC} = DV_{CC}, V_{SS} = DV_{SS} = 0\text{ V}$	2.4		3.6	V
T_A	Ambient temperature		-40		85	°C
f_{SD}	Modulator clock frequency		0.03		2.3	MHz
V_I	Absolute input voltage		$V_{SS} - 1$		V_{CC}	V
V_{IC}	Common-mode input voltage		$V_{SS} - 1$		V_{CC}	V
$V_{ID,FS}$	Differential full-scale input voltage	Bipolar mode, $V_{ID} = V_{I,A+} - V_{I,A-}$	$-V_{REF}/GAIN$		$+V_{REF}/GAIN$	mV
V_{ID}	Differential input voltage for specified performance ⁽¹⁾	REFON = 1	SD24GAINx = 1	±900	±930	mV
			SD24GAINx = 2	±450	±460	
			SD24GAINx = 4	±225	±230	
			SD24GAINx = 8	±112	±120	
			SD24GAINx = 16	±56	±60	
			SD24GAINx = 32	±28	±30	
			SD24GAINx = 64	±14	±14	
			SD24GAINx = 128	±7	±7.25	
C_{REF}	VREF load capacitance ⁽²⁾	SD24REFS = 1		100		nF

- (1) The full-scale range (FSR) is defined by $V_{FS+} = +V_{REF}/GAIN$ and $V_{FS-} = -V_{REF}/GAIN$; $FSR = V_{FS+} - V_{FS-} = 2 \times V_{REF}/GAIN$. If V_{REF} is sourced externally, the analog input range should not exceed 80% of V_{FS+} or V_{FS-} , that is, $V_{ID} = 0.8 V_{FS-}$ to $0.8 V_{FS+}$. If V_{REF} is sourced internally, the given V_{ID} ranges apply. MIN values are calculated based on a V_{REF} of 1.125 V. TYP values are calculated based on a V_{REF} of 1.16 V.
- (2) There is no capacitance required on VREF. However, TI recommends using a capacitance of 100 nF to reduce any reference voltage noise.

Table 5-40 lists the analog input characteristics of the SD24_B.

Table 5-40. SD24_B, Analog Inputs ⁽¹⁾

Also see Figure 5-16

PARAMETER	TEST CONDITIONS	V_{CC}	MIN	TYP	MAX	UNIT
C_I Input capacitance	SD24GAINx = 1	3 V		5.0		pF
	SD24GAINx = 2			5.0		
	SD24GAINx = 4			5.0		
	SD24GAINx = 8			5.0		
	SD24GAINx = 16			5.0		
	SD24GAINx = 32, 64, 128			5.0		
Z_I Input impedance (pin A+ or A- to V_{SS})	$f_{SD24} = 1\text{ MHz}$	3 V	SD24GAINx = 1		200	kΩ
			SD24GAINx = 8		200	
			SD24GAINx = 32		200	
Z_{ID} Differential input impedance (pin A+ to pin A-)	$f_{SD24} = 1\text{ MHz}$	3 V	SD24GAINx = 1	300	400	kΩ
			SD24GAINx = 8		400	
			SD24GAINx = 32	300	400	

- (1) All parameters pertain to each SD24_B converter.

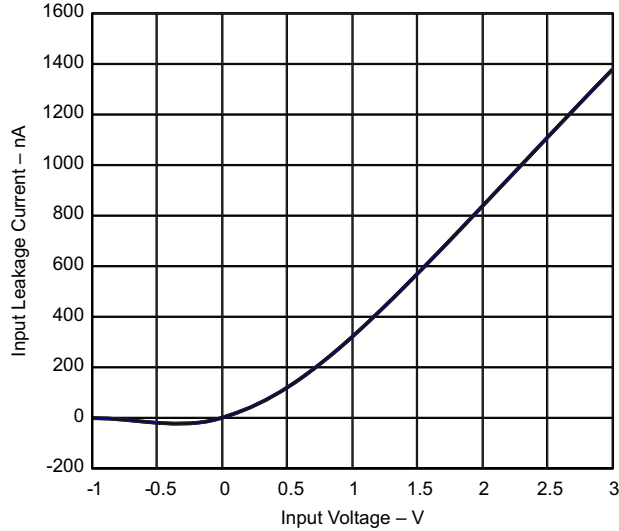

Figure 5-16. Input Leakage Current vs Input Voltage (Modulator OFF)

Table 5-41 lists the supply currents of the SD24_B.

Table 5-41. SD24_B, Supply Currents

PARAMETER	TEST CONDITIONS	V _{CC}	MIN	TYP	MAX	UNIT			
I _{SD,256}	Analog plus digital supply current per converter (reference not included) f _{SD24} = 1 MHz, SD24OSR = 256	3 V				μA	SD24GAIN: 1	490	600
							SD24GAIN: 2	490	600
							SD24GAIN: 4	490	600
							SD24GAIN: 8	559	700
							SD24GAIN: 16	559	700
							SD24GAIN: 32	627	800
							SD24GAIN: 64	627	800
							SD24GAIN: 128	627	800
I _{SD,512}	Analog plus digital supply current per converter (reference not included) f _{SD24} = 2 MHz, SD24OSR = 512	3 V				μA	SD24GAIN: 1	600	700
							SD24GAIN: 8	677	800
							SD24GAIN: 32	740	900
I _{SD24REFonly}	Current of internal SD24 reference and buffers (includes shared reference)	No converter is active, (SD24REFS = 1, SD24BCCTLx.SD24SC = 0)	3 V		147	190	μA		
I _{SD24REF_Conv0}	Current of internal SD24 reference and buffers (includes shared reference)	Converter 0 is active, (SD24REFS = 1, SD24BCCTL0.SD24SC = 1)	3 V	75	110	μA			
I _{SD24REF_notConv0}	Current of internal SD24 reference and buffers (includes shared reference)	Any converter other than converter 0 is active, (SD24REFS = 1, SD24BCCTL0.SD24SC = 0, SD24BCCTLx.SD24SC = 1)	3 V	137	175	μA			

Table 5-42 lists the performance characteristics of the SD24_B.

Table 5-42. SD24_B, Performance

$f_{SD24} = 1 \text{ MHz}$, $SD24OSRx = 256$, $SD24REFON = 1$

PARAMETER		TEST CONDITIONS	V _{CC}	MIN	TYP	MAX	UNIT
INL	Integral nonlinearity, end-point fit	SD24GAIN: 1	3 V	-0.01		+0.01	% of FSR
		SD24GAIN: 8		-0.01		+0.01	
		SD24GAIN: 32		-0.01		+0.01	
G _{nom}	Nominal gain	SD24GAIN: 1	3 V		1		
		SD24GAIN: 2			2		
		SD24GAIN: 4			4		
		SD24GAIN: 8			8		
		SD24GAIN: 16			16		
		SD24GAIN: 32			32		
		SD24GAIN: 64			64		
		SD24GAIN: 128			128		
E _G	Gain error ⁽¹⁾	SD24GAIN: 1, with external reference (1.2 V)	3 V	-1%		+1%	
		SD24GAIN: 8, with external reference (1.2 V)		-2%		+2%	
		SD24GAIN: 32, with external reference (1.2 V)		-2%		+2%	
ΔE _G /ΔT	Gain error temperature coefficient ⁽²⁾ , internal reference	SD24GAIN: 1, 8, or 32 (with internal reference)	3 V			80	ppm/°C
ΔE _G /ΔT	Gain error temperature coefficient ⁽²⁾ , external reference	SD24GAIN: 1 (with external reference)	3 V			15	ppm/°C
		SD24GAIN: 8 (with external reference)				15	
		SD24GAIN: 32 (with external reference)				15	
ΔE _G /ΔV _{CC}	Gain error vs V _{CC} ⁽³⁾	SD24GAIN: 1	3 V		0.1		%V
		SD24GAIN: 8			0.1		
		SD24GAIN: 32			0.4		
E _{OS} [V]	Offset error ⁽⁴⁾	SD24GAIN: 1 (with V _{diff} = 0 V)	3 V			2.3	mV
		SD24GAIN: 8				1	
		SD24GAIN: 32				0.5	
E _{OS} [FS]	Offset error ⁽⁴⁾	SD24GAIN: 1 (with V _{diff} = 0 V)	3 V	-0.2		+0.2	% FS
		SD24GAIN: 8		-0.7		+0.7	
		SD24GAIN: 32		-1.4		+1.4	
ΔE _{OS} /ΔT	Offset error temperature coefficient ⁽⁵⁾	SD24GAIN: 1	3 V		2		μV/°C
		SD24GAIN: 8			0.25		
		SD24GAIN: 32			0.1		

- The gain error E_G specifies the deviation of the actual gain G_{act} from the nominal gain G_{nom}: $E_G = (G_{act} - G_{nom})/G_{nom}$. It covers process, temperature, and supply voltage variations.
- The gain error temperature coefficient ΔE_G/ΔT specifies the variation of the gain error E_G over temperature ($E_G(T) = (G_{act}(T) - G_{nom})/G_{nom}$) using the box method (that is, minimum and maximum values):
 $\Delta E_G / \Delta T = (MAX(E_G(T)) - MIN(E_G(T))) / (MAX(T) - MIN(T)) = (MAX(G_{act}(T)) - MIN(G_{act}(T))) / G_{nom} / (MAX(T) - MIN(T))$
with T ranging from -40°C to 85°C.
- The gain error vs V_{CC} coefficient ΔE_G/ΔV_{CC} specifies the variation of the gain error E_G over supply voltage ($E_G(V_{CC}) = (G_{act}(V_{CC}) - G_{nom})/G_{nom}$) using the box method (that is, minimum and maximum values):
 $\Delta E_G / \Delta V_{CC} = (MAX(E_G(V_{CC})) - MIN(E_G(V_{CC}))) / (MAX(V_{CC}) - MIN(V_{CC})) = (MAX(G_{act}(V_{CC})) - MIN(G_{act}(V_{CC}))) / G_{nom} / (MAX(V_{CC}) - MIN(V_{CC}))$
with V_{CC} ranging from 2.4 V to 3.6 V.
- The offset error E_{OS} is measured with shorted inputs in 2s-complement mode with +100% FS = V_{REF}/G and -100% FS = -V_{REF}/G. Conversion between E_{OS} [FS] and E_{OS} [V] is as follows: E_{OS} [FS] = E_{OS} [V] × G/V_{REF}, E_{OS} [V] = E_{OS} [FS] × V_{REF}/G.
- The offset error temperature coefficient ΔE_{OS}/ΔT specifies the variation of the offset error E_{OS} over temperature using the box method (that is, minimum and maximum values):
 $\Delta E_{OS} / \Delta T = (MAX(E_{OS}(T)) - MIN(E_{OS}(T))) / (MAX(T) - MIN(T))$
with T ranging from -40°C to 85°C.

Table 5-42. SD24_B, Performance (continued)
 $f_{SD24} = 1 \text{ MHz}$, $SD24OSRx = 256$, $SD24REFON = 1$

PARAMETER		TEST CONDITIONS	V _{CC}	MIN	TYP	MAX	UNIT
$\Delta E_{OS}/\Delta V_{CC}$	Offset error vs V _{CC} ⁽⁶⁾	SD24GAIN: 1	3 V		500		$\mu\text{V/V}$
		SD24GAIN: 8			125		
		SD24GAIN: 32			50		
CMRR,DC	Common-mode rejection at DC ⁽⁷⁾	SD24GAIN: 1	3 V		-120		dB
		SD24GAIN: 8			-110		
		SD24GAIN: 32			-100		
CMRR,50Hz	Common-mode rejection at 50 Hz ⁽⁸⁾	SD24GAIN: 1, $f_{CM} = 50 \text{ Hz}$, $V_{CM} = 930 \text{ mV}$	3 V		-120		dB
		SD24GAIN: 8, $f_{CM} = 50 \text{ Hz}$, $V_{CM} = 120 \text{ mV}$			-110		
		SD24GAIN: 32, $f_{CM} = 50 \text{ Hz}$, $V_{CM} = 30 \text{ mV}$			-100		
AC PSRR, ext	AC power supply rejection ratio, external reference ⁽⁹⁾	SD24GAIN: 1, $V_{CC} = 3 \text{ V} + 50 \text{ mV} \times \sin(2\pi \times f_{VCC} \times t)$, $f_{VCC} = 50 \text{ Hz}$			-61		dB
		SD24GAIN: 8, $V_{CC} = 3 \text{ V} + 50 \text{ mV} \times \sin(2\pi \times f_{VCC} \times t)$, $f_{VCC} = 50 \text{ Hz}$			-75		
		SD24GAIN: 32, $V_{CC} = 3 \text{ V} + 50 \text{ mV} \times \sin(2\pi \times f_{VCC} \times t)$, $f_{VCC} = 50 \text{ Hz}$			-79		
AC PSRR, int	AC power supply rejection ratio, internal reference ⁽⁹⁾	SD24GAIN: 1, $V_{CC} = 3 \text{ V} + 50 \text{ mV} \times \sin(2\pi \times f_{VCC} \times t)$, $f_{VCC} = 50 \text{ Hz}$			-61		dB
		SD24GAIN: 8, $V_{CC} = 3 \text{ V} + 50 \text{ mV} \times \sin(2\pi \times f_{VCC} \times t)$, $f_{VCC} = 50 \text{ Hz}$			-75		
		SD24GAIN: 32, $V_{CC} = 3 \text{ V} + 50 \text{ mV} \times \sin(2\pi \times f_{VCC} \times t)$, $f_{VCC} = 50 \text{ Hz}$			-79		
XT	Crosstalk between converters ⁽¹⁰⁾	Crosstalk source: SD24GAIN: 1, Sine-wave with maximum possible V _{pp} , $f_{IN} = 50 \text{ Hz}$ or 100 Hz , Converter under test: SD24GAIN: 1	3 V		-120		dB
		Crosstalk source: SD24GAIN: 1, Sine-wave with maximum possible V _{pp} , $f_{IN} = 50 \text{ Hz}$ or 100 Hz , Converter under test: SD24GAIN: 8			-115		
		Crosstalk source: SD24GAIN: 1, Sine-wave with maximum possible V _{pp} , $f_{IN} = 50 \text{ Hz}$ or 100 Hz , Converter under test: SD24GAIN: 32			-110		

- (6) The offset error vs V_{CC} $\Delta E_{OS}/\Delta V_{CC}$ specifies the variation of the offset error E_{OS} over supply voltage using the box method (that is, minimum and maximum values):

$$\Delta E_{OS}/\Delta V_{CC} = (\text{MAX}(E_{OS}(V_{CC})) - \text{MIN}(E_{OS}(V_{CC})) / (\text{MAX}(V_{CC}) - \text{MIN}(V_{CC}))$$
 with V_{CC} ranging from 2.4 V to 3.6 V.
- (7) The DC CMRR specifies the change in the measured differential input voltage value when the common-mode voltage varies:
 DC CMRR = $-20\log(\Delta_{MAX}/FSR)$ with Δ_{MAX} being the difference between the minimum value and the maximum value measured when sweeping the common-mode voltage.
 The DC CMRR is measured with both inputs connected to the common-mode voltage (that is, no differential input signal is applied), and the common-mode voltage is swept from -1 V to V_{CC}.
- (8) The AC CMRR is the difference between a hypothetical signal with the amplitude and frequency of the applied common-mode ripple applied to the inputs of the ADC and the actual common-mode signal spur visible in the FFT spectrum:
 AC CMRR = Error Spur [dBFS] - $20\log(V_{CM} / 1.2 \text{ V} / G)$ [dBFS] with a common-mode signal of $V_{CM} \times \sin(2\pi \times f_{CM} \times t)$ applied to the analog inputs.
 The AC CMRR is measured with the both inputs connected to the common-mode signal; that is, no differential input signal is applied. With the specified typical values the error spur is within the noise floor (as specified by the SINAD values).
- (9) The AC PSRR is the difference between a hypothetical signal with the amplitude and frequency of the applied supply voltage ripple applied to the inputs of the ADC and the actual supply voltage ripple spur visible in the FFT spectrum:
 AC PSRR = Error Spur [dBFS] - $20\log(50 \text{ mV} / 1.2 \text{ V} / G)$ [dBFS] with a signal of $50 \text{ mV} \times \sin(2\pi \times f_{VCC} \times t)$ added to V_{CC}.
 The AC PSRR is measured with the inputs grounded; that is, no analog input signal is applied. With the specified typical values the error spur is within the noise floor (as specified by the SINAD values).
 SD24GAIN: 1 → Hypothetical signal: $20\log(50 \text{ mV} / 1.2 \text{ V} / 1) = -27.6 \text{ dBFS}$
 SD24GAIN: 8 → Hypothetical signal: $20\log(50 \text{ mV} / 1.2 \text{ V} / 8) = -9.5 \text{ dBFS}$
 SD24GAIN: 32 → Hypothetical signal: $20\log(50 \text{ mV} / 1.2 \text{ V} / 32) = 2.5 \text{ dBFS}$
- (10) The crosstalk XT is specified as the tone level of the signal applied to the crosstalk source seen in the spectrum of the converter under test. It is measured with the inputs of the converter under test being grounded.

Table 5-43 lists the AC performance characteristics of the SD24_B.

Table 5-43. SD24_B, AC Performance

$f_{SD24} = 1 \text{ MHz}$, $SD24OSRx = 256$, $SD24REFON = 1$

PARAMETER		TEST CONDITIONS		V_{CC}	MIN	TYP	MAX	UNIT
SINAD	Signal-to-noise + distortion ratio	SD24GAIN: 1	$f_{IN} = 50 \text{ Hz}^{(1)}$	3 V	82	86		dB
		SD24GAIN: 2				85		
		SD24GAIN: 4				84		
		SD24GAIN: 8				81	83	
		SD24GAIN: 16				80		
		SD24GAIN: 32				71	73	
		SD24GAIN: 64				67		
		SD24GAIN: 128				61		
THD	Total harmonic distortion	SD24GAIN: 1	$f_{IN} = 50 \text{ Hz}^{(1)}$	3 V		95		dB
		SD24GAIN: 8				90		
		SD24GAIN: 32				86		

(1) The following voltages were applied to the SD24_B inputs: $V_{I,A+}(t) = 0 \text{ V} + V_{PP} / 2 \times \sin(2\pi \times f_{IN} \times t)$ and $V_{I,A-}(t) = 0 \text{ V} - V_{PP}/2 \times \sin(2\pi \times f_{IN} \times t)$ resulting in a differential voltage of $V_{ID} = V_{I,A+}(t) - V_{I,A-}(t) = V_{PP} \times \sin(2\pi \times f_{IN} \times t)$ with V_{PP} being selected as the maximum value allowed for a given range (according to SD24_B recommended operating conditions).

Table 5-44 lists the AC performance characteristics of the SD24_B.

Table 5-44. SD24_B, AC Performance

$f_{SD24} = 2 \text{ MHz}$, $SD24OSRx = 512$, $SD24REFON = 1$

PARAMETER		TEST CONDITIONS		V_{CC}	MIN	TYP	MAX	UNIT
SINAD	Signal-to-noise + distortion ratio	SD24GAIN: 1	$f_{IN} = 50 \text{ Hz}^{(1)}$	3 V		87		dB
		SD24GAIN: 2				85		
		SD24GAIN: 4				84		
		SD24GAIN: 8				83		
		SD24GAIN: 16				81		
		SD24GAIN: 32				76		
		SD24GAIN: 64				71		
		SD24GAIN: 128				65		

(1) The following voltages were applied to the SD24_B inputs: $V_{I,A+}(t) = 0 \text{ V} + V_{PP} / 2 \times \sin(2\pi \times f_{IN} \times t)$ and $V_{I,A-}(t) = 0 \text{ V} - V_{PP}/2 \times \sin(2\pi \times f_{IN} \times t)$ resulting in a differential voltage of $V_{ID} = V_{I,A+}(t) - V_{I,A-}(t) = V_{PP} \times \sin(2\pi \times f_{IN} \times t)$ with V_{PP} being selected as the maximum value allowed for a given range (according to SD24_B recommended operating conditions).

Table 5-45 lists the AC performance characteristics of the SD24_B.

Table 5-45. SD24_B, AC Performance

$f_{SD24} = 32$ kHz, $SD24OSRx = 512$, $SD24REFON = 1$ (see Figure 5-17 and Figure 5-18)

PARAMETER		TEST CONDITIONS	V_{CC}	MIN	TYP	MAX	UNIT
SINAD	Signal-to-noise + distortion ratio	SD24GAIN: 1	3 V				dB
		SD24GAIN: 2					
		SD24GAIN: 4					
		SD24GAIN: 8					
		SD24GAIN: 16					
		SD24GAIN: 32					
		SD24GAIN: 64					
		SD24GAIN: 128					

(1) The following voltages were applied to the SD24_B inputs: $V_{I,A+}(t) = 0 V + V_{PP} / 2 \times \sin(2\pi \times f_{IN} \times t)$ and $V_{I,A-}(t) = 0 V - V_{PP}/2 \times \sin(2\pi \times f_{IN} \times t)$ resulting in a differential voltage of $V_{ID} = V_{I,A+}(t) - V_{I,A-}(t) = V_{PP} \times \sin(2\pi \times f_{IN} \times t)$ with V_{PP} being selected as the maximum value allowed for a given range (according to SD24_B recommended operating conditions).

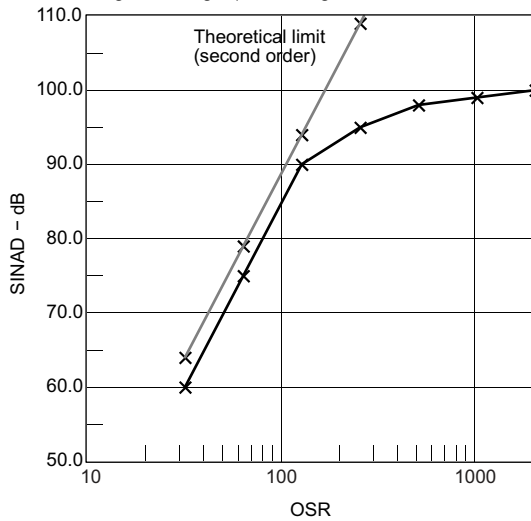

Figure 5-17. SINAD vs OSR
($f_{SD24} = 1$ MHz, $SD24REFON = 1$, $SD24GAIN = 1$)

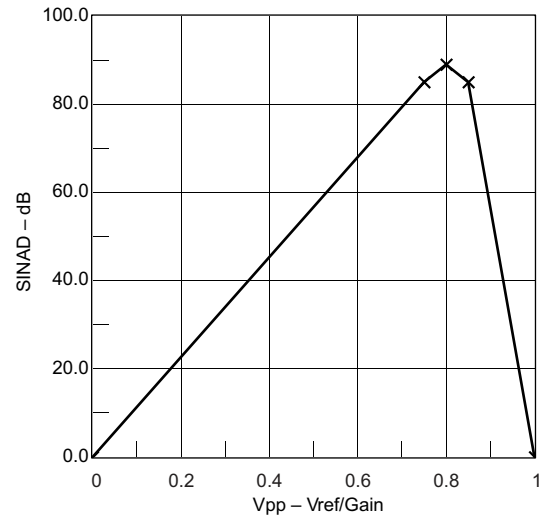

Figure 5-18. SINAD vs V_{PP}

Table 5-46 lists the external reference requirements of the SD24_B.

Table 5-46. SD24_B External Reference Input

ensure correct input voltage range according to V_{REF}

PARAMETER		TEST CONDITIONS	V_{CC}	MIN	TYP	MAX	UNIT
$V_{REF(I)}$	Input voltage	$SD24REFS = 0$	3 V	1.0	1.20	1.5	V
$I_{REF(I)}$	Input current	$SD24REFS = 0$	3 V			50	nA

5.17 ADC10_A

Table 5-47 lists the input requirements of the ADC.

Table 5-47. 10-Bit ADC, Power Supply and Input Range Conditions

over recommended ranges of supply voltage and operating free-air temperature (unless otherwise noted)

PARAMETER		TEST CONDITIONS	V _{CC}	MIN	TYP	MAX	UNIT
AV _{CC}	Analog supply voltage	AVCC and DVCC are connected together, AVSS and DVSS are connected together, V _(AVSS) = V _(DVSS) = 0 V		1.8		3.6	V
V _(Ax)	Analog input voltage range ⁽¹⁾	All ADC10_A pins		0		AV _{CC}	V
I _{ADC10_A}	Operating supply current into AVCC terminal, REF module and reference buffer off	f _{ADC10CLK} = 5 MHz, ADC10ON = 1, REFON = 0, SHT0 = 0, SHT1 = 0, ADC10DIV = 0, ADC10SREF = 00	2.2 V		68	100	μA
			3 V		78	110	
	Operating supply current into AVCC terminal, REF module on, reference buffer on	f _{ADC10CLK} = 5 MHz, ADC10ON = 1, REFON = 1, SHT0 = 0, SHT1 = 0, ADC10DIV = 0, ADC10SREF = 01	3 V		124	180	
		f _{ADC10CLK} = 5 MHz, ADC10ON = 1, REFON = 0, SHT0 = 0, SHT1 = 0, ADC10DIV = 0, ADC10SREF = 10, VREF = 2.5 V	3 V		105	160	
Operating supply current into AVCC terminal, REF module off, reference buffer off	f _{ADC10CLK} = 5 MHz, ADC10ON = 1, REFON = 0, SHT0 = 0, SHT1 = 0, ADC10DIV = 0, ADC10SREF = 11, VREF = 2.5 V	3 V		72	110		
C _I	Input capacitance	Only one terminal Ax can be selected at one time from the pad to the ADC10_A capacitor array including wiring and pad	2.2 V		3.5		pF
R _I	Input MUX ON resistance	AV _{CC} > 2.0 V, 0 V ≤ V _{Ax} ≤ AV _{CC}				36	kΩ
		1.8 V < AV _{CC} < 2.0 V, 0 V ≤ V _{Ax} ≤ AV _{CC}				96	

(1) The analog input voltage range must be within the selected reference voltage range V_{R+} to V_{R-} for valid conversion results. The external reference voltage requires decoupling capacitors. Connect two decoupling capacitors, 10 μF and 100 nF, to VREF to decouple the dynamic current required for an external reference source if it is used for the ADC10_A. Also see the [MSP430x5xx and MSP430x6xx Family User's Guide](#).

Table 5-48 lists the switching characteristics of the ADC.

Table 5-48. 10-Bit ADC, Switching Characteristics

over recommended ranges of supply voltage and operating free-air temperature (unless otherwise noted)

PARAMETER		TEST CONDITIONS	V _{CC}	MIN	TYP	MAX	UNIT
f _{ADC10CLK}		For specified performance of ADC10_A linearity parameters	2.2 V, 3 V	0.45	5	5.5	MHz
f _{ADC10OSC}	Internal ADC10_A oscillator ⁽¹⁾	ADC10DIV = 0, f _{ADC10CLK} = f _{ADC10OSC}	2.2 V, 3 V	4.4	4.9	5.6	MHz
t _{CONVERT}	Conversion time	REFON = 0, Internal oscillator, 12 ADC10CLK cycles, 10-bit mode, f _{ADC10OSC} = 4 MHz to 5 MHz	2.2 V, 3 V	2.4		3.0	μs
		External f _{ADC10CLK} from ACLK, MCLK, or SMCLK, ADC10SSEL ≠ 0			12 × 1 / f _{ADC10CLK}		
t _{ADC10ON}	Turn-on settling time of the ADC	See ⁽²⁾				100	ns
t _{Sample}	Sampling time	R _S = 1000 Ω, R _I = 96 kΩ, C _I = 3.5 pF ⁽³⁾	1.8 V	3			μs
		R _S = 1000 Ω, R _I = 36 kΩ, C _I = 3.5 pF ⁽³⁾	3 V	1			

(1) The ADC10OSC is sourced directly from MODOSC inside the UCS.

(2) The condition is that the error in a conversion started after t_{ADC10ON} is less than ±0.5 LSB. The reference and input signal are already settled.

(3) Approximately 8 Tau (τ) are needed to get an error of less than ±0.5 LSB

Table 5-49 lists the linearity parameters of the ADC.

Table 5-49. 10-Bit ADC, Linearity Parameters

over recommended ranges of supply voltage and operating free-air temperature (unless otherwise noted)

PARAMETER	TEST CONDITIONS	V _{CC}	MIN	MAX	UNIT
E _I Integral linearity error	1.4 V ≤ (V _{eREF+} - V _{eREF-}) ≤ 1.6 V, C _{VeREF+} = 20 pF	2.2 V, 3 V	-1.0	+1.0	LSB
	1.6 V < (V _{eREF+} - V _{eREF-}) ≤ V _{AVCC} , C _{VeREF+} = 20 pF		-1.0	+1.0	
E _D Differential linearity error	1.4 V ≤ (V _{eREF+} - V _{eREF-}), C _{VeREF+} = 20 pF	2.2 V, 3 V	-1.0	+1.0	LSB
E _O Offset error	1.4 V ≤ (V _{eREF+} - V _{eREF-}), C _{VeREF+} = 20 pF Internal impedance of source R _S < 100 Ω	2.2 V, 3 V	-1.0	+1.0	LSB
E _G Gain error	1.4 V ≤ (V _{eREF+} - V _{eREF-}), C _{VeREF+} = 20 pF, ADC10SREFX = 11b	2.2 V, 3 V	-1.0	+1.0	LSB
E _T Total unadjusted error	1.4 V ≤ (V _{eREF+} - V _{eREF-}), C _{VeREF+} = 20 pF, ADC10SREFX = 11b	2.2 V, 3 V	-2.0	+2.0	LSB

Table 5-50 lists the requirement for the ADC external reference.

Table 5-50. 10-Bit ADC, External Reference

over recommended ranges of supply voltage and operating free-air temperature (unless otherwise noted)⁽¹⁾

PARAMETER	TEST CONDITIONS	V _{CC}	MIN	MAX	UNIT
V _{eREF+} Positive external reference voltage input	V _{eREF+} > V _{eREF-} ⁽²⁾		1.4	AV _{CC}	V
V _{eREF-} Negative external reference voltage input	V _{eREF+} > V _{eREF-} ⁽³⁾		0	1.2	V
(V _{eREF+} - V _{eREF-}) Differential external reference voltage input	V _{eREF+} > V _{eREF-} ⁽⁴⁾		1.4	AV _{CC}	V
I _{VeREF+} , I _{VeREF-} Static input current	1.4 V ≤ V _{eREF+} ≤ V _{AVCC} , V _{eREF-} = 0 V, f _{ADC10CLK} = 5 MHz, ADC10SHTX = 0x0001, Conversion rate 200 ksps	2.2 V, 3 V	-26	+26	μA
	1.4 V ≤ V _{eREF+} ≤ V _{AVCC} , V _{eREF-} = 0 V, f _{ADC10CLK} = 5 MHz, ADC10SHTX = 0x1000, Conversion rate 20 ksps		-1	+1	
C _{VeREF+} Capacitance at VREF+ terminal	See ⁽⁵⁾		10		μF

- (1) The external reference is used during ADC conversion to charge and discharge the capacitance array. The input capacitance, C_I, is also the dynamic load for an external reference during conversion. The dynamic impedance of the reference supply should follow the recommendations on analog-source impedance to allow the charge to settle for 10-bit accuracy.
- (2) The accuracy limits the minimum positive external reference voltage. Lower reference voltage levels may be applied with reduced accuracy requirements.
- (3) The accuracy limits the maximum negative external reference voltage. Higher reference voltage levels may be applied with reduced accuracy requirements.
- (4) The accuracy limits minimum external differential reference voltage. Lower differential reference voltage levels may be applied with reduced accuracy requirements.
- (5) Connect two decoupling capacitors, 10 μF and 100 nF, to VREF to decouple the dynamic current required for an external reference source if it is used for the ADC10_A. Also see the [MSP430x5xx and MSP430x6xx Family User's Guide](#).

5.18 REF

Table 5-51 lists the characteristics of the REF.

Table 5-51. REF Built-In Reference

over recommended ranges of supply voltage and operating free-air temperature (unless otherwise noted)

PARAMETER	TEST CONDITIONS	V _{CC}	MIN	TYP	MAX	UNIT	
V _{REF+}	Positive built-in reference voltage	REFVSEL = {2} for 2.5 V, REFON = 1	3 V	2.47	2.51	2.55	V
		REFVSEL = {1} for 2 V, REFON = 1		1.96	1.99	2.02	
		REFVSEL = {0} for 1.5 V, REFON = 1	2.2 V, 3 V	1.48	1.5	1.52	
AV _{CC(min)}	AV _{CC} minimum voltage, Positive built-in reference active	REFVSEL = {0} for 1.5 V		1.8		V	
		REFVSEL = {1} for 2 V		2.2			
		REFVSEL = {2} for 2.5 V		2.7			
I _{REF+}	Operating supply current into AV _{CC} terminal ⁽¹⁾	f _{ADC10CLK} = 5.0 MHz, REFON = 1, REFBURST = 0, REFVSEL = {2} for 2.5 V	3 V	18	24	μA	
		f _{ADC10CLK} = 5.0 MHz, REFON = 1, REFBURST = 0, REFVSEL = {1} for 2 V		16.1	21		
		f _{ADC10CLK} = 5.0 MHz, REFON = 1, REFBURST = 0, REFVSEL = {0} for 1.5 V		14.4	21		
TC _{REF+}	Temperature coefficient of built-in reference ⁽²⁾	I _{VREF+} = 0 A, REFVSEL = {0, 1, 2}, REFON = 1		< 18	50	ppm/ °C	
I _{SENSOR}	Operating supply current into AV _{CC} terminal ⁽³⁾	REFON = 0, INCH = 0Ah, ADC10ON = N/A, T _A = 30°C	2.2 V	17	22	μA	
			3 V	17	22		
V _{SENSOR}	See ⁽⁴⁾	ADC10ON = 1, INCH = 0Ah, T _A = 30°C	2.2 V	770		mV	
			3 V	770			
V _{MID}	AV _{CC} divider at channel 11	ADC10ON = 1, INCH = 0Bh, V _{MID} ≈ 0.5 × V _{AVCC}	2.2 V	1.06	1.1	1.14	V
			3 V	1.46	1.5	1.54	
t _{SENSOR(sample)}	Sample time required if channel 10 is selected ⁽⁵⁾	ADC10ON = 1, INCH = 0Ah, Error of conversion result ≤ 1 LSB		30		μs	
t _{VMID(sample)}	Sample time required if channel 11 is selected ⁽⁶⁾	ADC10ON = 1, INCH = 0Bh, Error of conversion result ≤ 1 LSB		1		μs	
PSRR _{DC}	Power supply rejection ratio (DC)	AV _{CC} = AV _{CC} (min) to AV _{CC} (max), T _A = 25°C, REFVSEL = {0, 1, 2}, REFON = 1		120		μV/V	
PSRR _{AC}	Power supply rejection ratio (AC)	AV _{CC} = AV _{CC} (min) to AV _{CC} (max), T _A = 25°C, f = 1 kHz, ΔV _{pp} = 100 mV, REFVSEL = {0, 1, 2}, REFON = 1		6.4		mV/V	
t _{SETTLE}	Settling time of reference voltage ⁽⁷⁾	AV _{CC} = AV _{CC} (min) to AV _{CC} (max), REFVSEL = {0, 1, 2}, REFON = 0 → 1		75		μs	
V _{SD24REF}	SD24_B internal reference voltage	SD24REFS = 1	3 V	1.151	1.1623	1.174	V
t _{ON}	SD24_B internal reference turnon time	SD24REFS = 0 → 1, C _{REF} = 100 nF	3 V		200		μs

(1) The internal reference current is supplied from the AV_{CC} terminal. Consumption is independent of the ADC10ON control bit, unless a conversion is active. The REFON bit enables to settle the built-in reference before starting an analog-to-digital conversion.

(2) Calculated using the box method: (MAX(−40°C to 85°C) − MIN(−40°C to 85°C)) / MIN(−40°C to 85°C)/(85°C − (−40°C)).

(3) The sensor current I_{SENSOR} is consumed if (ADC10ON = 1 and REFON = 1) or (ADC10ON = 1 and INCH = 0Ah and sample signal is high). When REFON = 1, I_{SENSOR} is already included in I_{REF+}.

(4) The temperature sensor offset can be significant. TI recommends a single-point calibration to minimize the offset error of the built-in temperature sensor.

(5) The typical equivalent impedance of the sensor is 51 kΩ. The sample time required includes the sensor-on time t_{SENSOR(on)}.

(6) The on-time t_{VMID(on)} is included in the sampling time t_{VMID(sample)}; no additional on time is needed.

(7) The condition is that the error in a conversion started after t_{REFON} is less than ±0.5 LSB.

5.19 Comparator_B

Table 5-52 lists the characteristics of the comparator.

Table 5-52. Comparator_B

over recommended ranges of supply voltage and operating free-air temperature (unless otherwise noted)

PARAMETER		TEST CONDITIONS	V _{CC}	MIN	TYP	MAX	UNIT
V _{CC}	Supply voltage			1.8		3.6	V
I _{AVCC_COMP}	Comparator operating supply current into AVCC, excludes reference resistor ladder	CBPWRMD = 00, CBON = 1, CBR _{Sx} = 00	1.8 V			40	μA
			2.2 V		22	50	
			3 V		32	65	
		2.2 V, 3 V		10	30		
				0.2	0.85		
I _{AVCC_REF}	Quiescent current of resistor ladder into AVCC, includes REF module current	CBREFACC = 1, CBREFL _x = 01, CBR _{Sx} = 10, REFON = 0, CBON = 0	2.2 V, 3 V		10	22	μA
						33	
V _{IC}	Common-mode input range			0		V _{CC} – 1	V
V _{OFFSET}	Input offset voltage	CBPWRMD = 00		–20		20	mV
		CBPWRMD = 01 or 10		–20		20	
C _{IN}	Input capacitance				5		pF
R _{SIN}	Series input resistance	On (switch closed)			3	4	kΩ
		Off (switch open)		50			MΩ
t _{PD}	Propagation delay, response time	CBPWRMD = 00, CBF = 0				450	ns
		CBPWRMD = 01, CBF = 0				600	
		CBPWRMD = 10, CBF = 0					50
t _{PD,filter}	Propagation delay with filter active	CBPWRMD = 00, CBON = 1, CBF = 1, CBF _{DLY} = 00		0.30	0.6	1.5	μs
		CBPWRMD = 00, CBON = 1, CBF = 1, CBF _{DLY} = 01		0.5	1.0	1.8	
		CBPWRMD = 00, CBON = 1, CBF = 1, CBF _{DLY} = 10		0.8	1.8	3.4	
		CBPWRMD = 00, CBON = 1, CBF = 1, CBF _{DLY} = 11		1.5	3.4	6.5	
t _{EN_CMP}	Comparator enable time	CBON = 0 to CBON = 1, CBPWRMD = 00 or 01			1	2	μs
		CBON = 0 to CBON = 1, CBPWRMD = 10				100	
t _{EN_REF}	Resistor reference enable time	CBON = 0 to CBON = 1			1.0	1.5	μs
TC _{REF}	Temperature coefficient reference					50	ppm/°C
V _{CB_REF}	Reference voltage for a given tap	V _{IN} = reference into resistor ladder, n = 0 to 31		V _{IN} × (n + 1.5) / 32	V _{IN} × (n + 1) / 32	V _{IN} × (n + 0.5) / 32	V

5.20 Flash

Table 5-53 lists the characteristics of the flash memory.

Table 5-53. Flash Memory

over recommended ranges of supply voltage and operating free-air temperature (unless otherwise noted)

PARAMETER		T _J	MIN	TYP	MAX	UNIT
DV _{CC(PGM/ERASE)}	Program and erase supply voltage		1.8		3.6	V
I _{PGM}	Average supply current from DVCC during program			3	5	mA
I _{ERASE}	Average supply current from DVCC during erase			6	15	mA
I _{MERASE} , I _{BANK}	Average supply current from DVCC during mass erase or bank erase			6	15	mA
t _{CPT}	Cumulative program time ⁽¹⁾				16	ms
	Program and erase endurance		10 ⁴	10 ⁵		cycles
t _{Retention}	Data retention duration	25°C	100			years
t _{Word}	Word or byte program time ⁽²⁾		64		85	μs
t _{Block, 0}	Block program time for first byte or word ⁽²⁾		49		65	μs
t _{Block, 1–(N–1)}	Block program time for each additional byte or word, except for last byte or word ⁽²⁾		37		49	μs
t _{Block, N}	Block program time for last byte or word ⁽²⁾		55		73	μs
t _{Erase}	Erase time for segment erase, mass erase, and bank erase when available ⁽²⁾		23		32	ms
f _{MCLK,MGR}	MCLK frequency in marginal read mode (FCTL4.MGR0 = 1 or FCTL4.MGR1 = 1)		0		1	MHz

(1) The cumulative program time must not be exceeded when writing to a 128-byte flash block. This parameter applies to all programming methods: individual word or byte write and block write modes.

(2) These values are hardwired into the state machine of the flash controller.

5.21 Emulation and Debug

Table 5-54 lists the characteristics of the JTAG and SBW interface.

Table 5-54. JTAG and Spy-Bi-Wire (SBW) Interface

over recommended ranges of supply voltage and operating free-air temperature (unless otherwise noted)

PARAMETER		V _{CC}	MIN	TYP	MAX	UNIT
f _{SBW}	Spy-Bi-Wire input frequency	2.2 V, 3 V	0		20	MHz
t _{SBW,Low}	Spy-Bi-Wire low clock pulse duration	2.2 V, 3 V	0.025		15	μs
t _{SBW,En}	Spy-Bi-Wire enable time (TEST high to acceptance of first clock edge) ⁽¹⁾	2.2 V, 3 V			1	μs
t _{SBW,Rst}	Spy-Bi-Wire return to normal operation time		15		100	μs
f _{TCK}	TCK input frequency for 4-wire JTAG ⁽²⁾	2.2 V	0		5	MHz
		3 V	0		10	MHz
R _{internal}	Internal pulldown resistance on TEST	2.2 V, 3 V	45	60	80	kΩ

(1) Tools that access the Spy-Bi-Wire interface must wait for the minimum t_{SBW,En} time after pulling the TEST/SBWTCK pin high before applying the first SBWTCK clock edge.

(2) f_{TCK} may be restricted to meet the timing requirements of the module selected.

6 Detailed Description

6.1 Overview

The TI MSP430F67xxA family of polyphase metering SoCs are powerful highly-integrated solutions for revenue meters that offer accuracy and low system cost with few external components. The MSP430F67xxA uses the low-power MSP430 CPU with a 32-bit multiplier to perform all energy calculations, metering applications such as tariff rate management, and communications with AMR and AMI modules.

6.2 Functional Block Diagrams

Figure 6-1 shows the functional block diagram for the MSP430F677xA, MSP430F676xA, and MSP430F674xA devices in the PEU package.

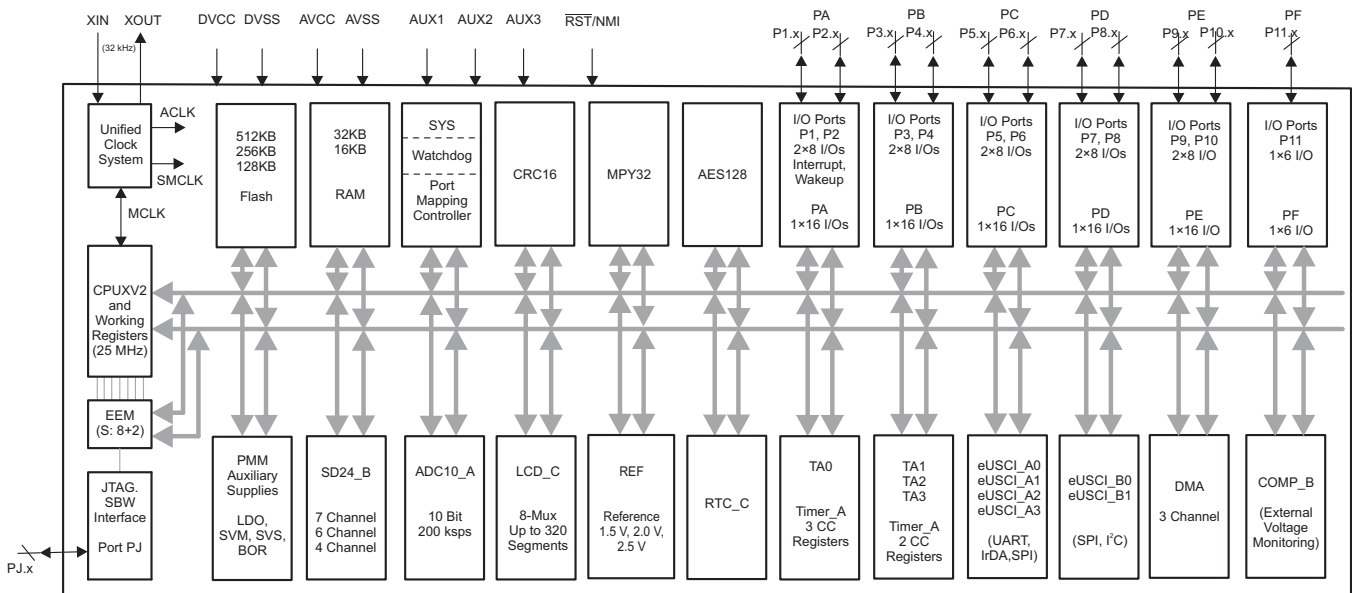

Copyright © 2016, Texas Instruments Incorporated

Figure 6-1. Functional Block Diagram – PEU Package

Figure 6-2 shows the functional block diagram for the MSP430F677xA, MSP430F676xA, and MSP430F674xA devices in the PZ package.

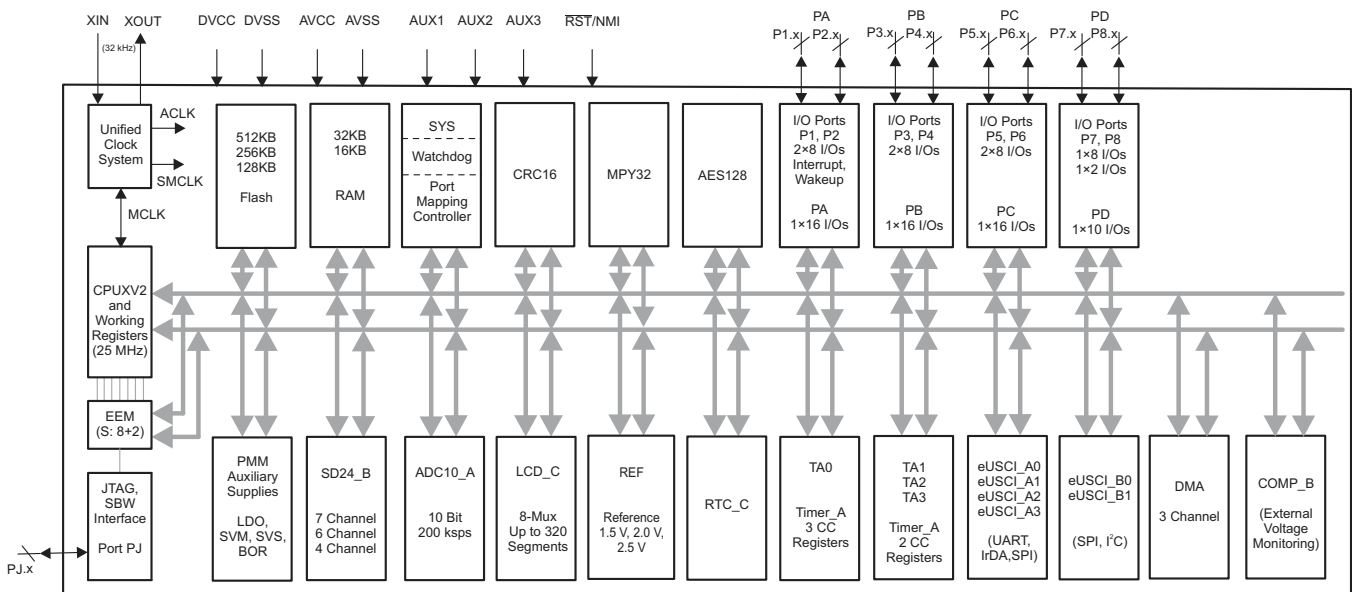

Copyright © 2016, Texas Instruments Incorporated

Figure 6-2. Functional Block Diagram – PZ Package

6.3 CPU ([Link to User's Guide](#))

The MSP430 CPU has a 16-bit RISC architecture that is highly transparent to the application. All operations, other than program-flow instructions, are performed as register operations in conjunction with seven addressing modes for source operand and four addressing modes for destination operand.

The CPU is integrated with 16 registers that provide reduced instruction execution time. The register-to-register operation execution time is one cycle of the CPU clock. Four of the registers, R0 to R3, are dedicated as program counter, stack pointer, status register, and constant generator, respectively. The remaining registers are general-purpose registers (see [Figure 6-3](#)).

Peripherals are connected to the CPU using data, address, and control buses. Peripherals can be managed with all instructions.

Program Counter	PC/R0
Stack Pointer	SP/R1
Status Register	SR/CG1/R2
Constant Generator	CG2/R3
General-Purpose Register	R4
General-Purpose Register	R5
General-Purpose Register	R6
General-Purpose Register	R7
General-Purpose Register	R8
General-Purpose Register	R9
General-Purpose Register	R10
General-Purpose Register	R11
General-Purpose Register	R12
General-Purpose Register	R13
General-Purpose Register	R14
General-Purpose Register	R15

Figure 6-3. CPU Registers

6.4 Instruction Set

The instruction set consists of the original 51 instructions with three formats and seven address modes and additional instructions for the expanded address range. Each instruction can operate on word and byte data. [Table 6-1](#) lists examples of the three types of instruction formats. [Table 6-2](#) lists the address modes.

Table 6-1. Instruction Word Formats

INSTRUCTION WORD FORMAT	EXAMPLE	OPERATION
Dual operands, source and destination	ADD R4,R5	R4 + R5 → R5
Single operands, destination only	CALL R8	PC → (TOS), R8 → PC
Relative jump, conditional or unconditional	JNE	Jump-on-equal bit = 0

Table 6-2. Address Mode Descriptions

ADDRESS MODE	S ⁽¹⁾	D ⁽¹⁾	SYNTAX	EXAMPLE	OPERATION
Register	✓	✓	MOV Rs,Rd	MOV R10,R11	R10 → R11
Indexed	✓	✓	MOV X(Rn),Y(Rm)	MOV 2(R5),6(R6)	M(2+R5) → M(6+R6)
Symbolic (PC relative)	✓	✓	MOV EDE,TONI		M(EDE) → M(TONI)
Absolute	✓	✓	MOV & MEM, & TCDAT		M(MEM) → M(TCDAT)
Indirect	✓		MOV @Rn,Y(Rm)	MOV @R10,Tab(R6)	M(R10) → M(Tab+R6)
Indirect autoincrement	✓		MOV @Rn+,Rm	MOV @R10+,R11	M(R10) → R11 R10 + 2 → R10
Immediate	✓		MOV #X,TONI	MOV #45,TONI	#45 → M(TONI)

(1) S = source, D = destination

6.5 Operating Modes

These microcontrollers have one active mode and six software-selectable low-power modes of operation. An interrupt event can wake up the device from any of the five low-power modes, service the request, and restore back to the low-power mode on return from the interrupt program.

Software can configure the following operating modes:

- Active mode (AM)
 - All clocks are active
- Low-power mode 0 (LPM0)
 - CPU is disabled
 - ACLK and SMCLK remain active, MCLK is disabled
 - FLL loop control remains active
- Low-power mode 1 (LPM1)
 - CPU is disabled
 - FLL loop control is disabled
 - ACLK and SMCLK remain active, MCLK is disabled
- Low-power mode 2 (LPM2)
 - CPU is disabled
 - MCLK and FLL loop control and DCOCLK are disabled
 - DC generator of the DCO remains enabled
 - ACLK remains active
- Low-power mode 3 (LPM3)
 - CPU is disabled
 - MCLK, FLL loop control, and DCOCLK are disabled
 - DC generator of the DCO is disabled
 - ACLK remains active
- Low-power mode 4 (LPM4)
 - CPU is disabled
 - ACLK is disabled
 - MCLK, FLL loop control, and DCOCLK are disabled
 - DC generator of the DCO is disabled
 - Crystal oscillator is stopped
 - Complete data retention
- Low-power mode 3.5 (LPM3.5)
 - Internal regulator disabled
 - No RAM retention, backup RAM retained
 - I/O pad state retention
 - RTC clocked by low-frequency oscillator
 - Wake-up input from $\overline{\text{RST/NMI}}$, RTC_C events, port P1, or port P2
- Low-power mode 4.5 (LPM4.5)
 - Internal regulator disabled
 - No RAM retention, backup RAM retained
 - RTC is disabled
 - I/O pad state retention
 - Wake-up input from $\overline{\text{RST/NMI}}$, port P1, or port P2

6.6 Interrupt Vector Addresses

The interrupt vectors and the power-up start address are in the address range 0FFFFh to 0FF80h (see [Table 6-3](#)). The vector contains the 16-bit address of the appropriate interrupt-handler instruction sequence.

Table 6-3. Interrupt Sources, Flags, and Vectors

INTERRUPT SOURCE	INTERRUPT FLAG	SYSTEM INTERRUPT	WORD ADDRESS	PRIORITY
System Reset Power up External reset Watchdog time-out, key violation Flash memory key violation	WDTIFG, KEYV (SYSRSTIV) ^{(1) (2)}	Reset	0FFFEh	63, highest
System NMI PMM Vacant memory access JTAG mailbox	SVMLIFG, SVMHIFG, DLYLIFG, DLYHIFG, VLRIFG, VLRHIFG, VMAIFG, JMBINIFG, JMBOUTIFG (SYSSNIV) ^{(1) (3)}	(Non)maskable	0FFFCh	62
User NMI NMI Oscillator fault Flash memory access violation Supply switched	NMIIFG, OFIFG, ACCVIFG, AUXSWGIFG (SYSUNIV) ^{(1) (3)}	(Non)maskable	0FFFAh	61
Watchdog Timer_A interval timer mode	WDTIFG	Maskable	0FFF8h	60
eUSCI_A0 receive or transmit	UCA0RXIFG, UCA0TXIFG (UCA0IV) ^{(1) (4)}	Maskable	0FFF6h	59
eUSCI_B0 receive or transmit	UCB0RXIFG, UCB0TXIFG (UCB0IV) ^{(1) (4)}	Maskable	0FFF4h	58
ADC10_A	ADC10IFG0, ADC10INIFG, ADC10LOIFG, ADC10HIIFG, ADC10TOVIFG, ADC10OVIFG (ADC10IV) ^{(1) (4)}	Maskable	0FFF2h	57
SD24_B	SD24_B Interrupt Flags (SD24IV) ^{(1) (4)}	Maskable	0FFF0h	56
Timer TA0	TA0CCR0 CCIFG0 ⁽⁴⁾	Maskable	0FFEEh	55
Timer TA0	TA0CCR1 CCIFG1, TA0CCR2 CCIFG2, TA0IFG (TA0IV) ^{(1) (4)}	Maskable	0FFECCh	54
eUSCI_A1 receive or transmit	UCA1RXIFG, UCA1TXIFG (UCA1IV) ^{(1) (4)}	Maskable	0FFEAh	53
eUSCI_A2 receive or transmit	UCA2RXIFG, UCA2TXIFG (UCA2IV) ^{(1) (4)}	Maskable	0FFE8h	52
Auxiliary supplies	AUXSWGIFG, AUXIFG0, AUXIFG1, AUXIFG2 (AUXIV) ^{(1) (4)}	Maskable	0FFE6h	51
DMA	DMA0IFG, DMA1IFG, DMA2IFG (DMAIV) ^{(1) (4)}	Maskable	0FFE4h	50
Timer TA1	TA1CCR0 CCIFG0 ⁽⁴⁾	Maskable	0FFE2h	49
Timer TA1	TA1CCR1 CCIFG1, TA1IFG (TA1IV) ^{(1) (4)}	Maskable	0FFE0h	48
eUSCI_A3 receive or transmit	UCA3RXIFG, UCA3TXIFG (UCA3IV) ^{(1) (4)}	Maskable	0FFDEh	47
eUSCI_B1 receive or transmit	UCB1RXIFG, UCB1TXIFG (UCB1IV) ^{(1) (4)}	Maskable	0FFDCh	46
I/O port P1	P1IFG.0 to P1IFG.7 (P1IV) ^{(1) (4)}	Maskable	0FFDAh	45
Timer TA2	TA2CCR0 CCIFG0 ⁽⁴⁾	Maskable	0FFD8h	44
Timer TA2	TA2CCR1 CCIFG1, TA2IFG (TA2IV) ^{(1) (4)}	Maskable	0FFD6h	43
I/O port P2	P2IFG.0 to P2IFG.7 (P2IV) ^{(1) (4)}	Maskable	0FFD4h	42
Timer TA3	TA3CCR0 CCIFG0 ⁽⁴⁾	Maskable	0FFD2h	41
Timer TA3	TA3CCR1 CCIFG1, TA3IFG (TA3IV) ^{(1) (4)}	Maskable	0FFD0h	40
LCD_C	LCD_C Interrupt Flags (LCDCIV) ^{(1) (4)}	Maskable	0FFCEh	39

(1) Multiple source flags

(2) A reset is generated if the CPU tries to fetch instructions from within peripheral space or vacant memory space.

(3) (Non)maskable: the individual interrupt enable bit can disable an interrupt event, but the general interrupt enable bit cannot disable it.

(4) Interrupt flags are in the module.

Table 6-3. Interrupt Sources, Flags, and Vectors (continued)

INTERRUPT SOURCE	INTERRUPT FLAG	SYSTEM INTERRUPT	WORD ADDRESS	PRIORITY
RTC_C	RTCOFIFG, RTCRDYIFG, RTCTEVIFG, RTCAIFG, RT0PSIFG, RT1PSIFG (RTCIV) ^{(1) (4)}	Maskable	0FFCCh	38
Comparator_B	Comparator_B Interrupt Flags (CBIV) ⁽¹⁾	Maskable	0FFCAh	37
AES	AESRDYIFG	Maskable	0FFC8h	36
Reserved	Reserved ⁽⁵⁾		0FFC6h	35
			:	:
			0FF80h	0, lowest

(5) Reserved interrupt vectors at addresses are not used in this device and can be used for regular program code if necessary. To maintain compatibility with other devices, TI recommends reserving these locations.

6.7 Special Function Registers (SFRs)

The SFRs are in the lowest address space and can be accessed in word or byte formats.

Legend

rw	Bit can be read and written.
rw-0, rw-1	Bit can be read and written. It is reset or set by PUC.
rw-(0), rw-(1)	Bit can be read and written. It is reset or set by POR.
rw-[0], rw-[1]	Bit can be read and written. It is reset or set by BOR.
–	SFR bit is not present in device.

Figure 6-4. Interrupt Enable 1 Register

15	14	13	12	11	10	9	8
–	–	–	–	–	–	AUXSWNMIE	–
rw-0							
7	6	5	4	3	2	1	0
JMBOUTIE	JMBINIE	ACCVIE	NMIIE	VMAIE	–	OFIE	WDTIE
rw-0	rw-0	rw-0	rw-0	rw-0		rw-0	rw-0

Table 6-4. Interrupt Enable 1 Register Description

Bit	Field	Type	Reset	Description
9	AUXSWNMIE	RW	0h	Supply switched nonmaskable interrupt enable
7	JMBOUTIE	RW	0h	JTAG mailbox output interrupt enable
6	JMBINIE	RW	0h	JTAG mailbox input interrupt enable
5	ACCVIE	RW	0h	Flash access violation interrupt enable
4	NMIIE	RW	0h	Nonmaskable interrupt enable
3	VMAIE	RW	0h	Vacant memory access interrupt enable
1	OFIE	RW	0h	Oscillator fault interrupt enable
0	WDTIE	RW	0h	Watchdog timer interrupt enable. Inactive if watchdog mode is selected. Active if watchdog timer is configured as a general-purpose timer.

Figure 6-5. Interrupt Flag 1 Register

15	14	13	12	11	10	9	8
–	–	–	–	–	–	–	–
7	6	5	4	3	2	1	0
JMBOUTIFG	JMBINIFG	–	NMIIFG	VMAIFG	–	OFIFG	WDTIFG
rw-[0]	rw-[0]		rw-0	rw-0		rw-0	rw-0

Table 6-5. Interrupt Flag 1 Register Description

Bit	Field	Type	Reset	Description
7	JMBOUTIFG	RW	0h	Set on JTAG mailbox output register ready for next message
6	JMBINIFG	RW	0h	Set on JTAG mailbox input message
4	NMIIFG	RW	0h	Set by $\overline{\text{RST}}/\text{NMI}$ pin
3	VMAIFG	RW	0h	Set on vacant memory access
1	OFIFG	RW	0h	Flag set on oscillator fault
0	WDTIFG	RW	0h	Set on watchdog timer overflow (in watchdog mode) or security key violation. Reset on V_{CC} power-on or a reset condition at the $\overline{\text{RST}}/\text{NMI}$ pin in reset mode.

6.8 Bootloader (BSL)

The BSL enables users to program the flash memory or RAM using various serial interfaces. Table 6-6 lists the BSL interface pin requirements. Access to the device memory by the BSL is protected by a user-defined password. BSL entry requires a specific entry sequence on the $\overline{\text{RST}}/\text{NMI}/\text{SBWTDIO}$ and $\text{TEST}/\text{SBWTCK}$ pins. For a complete description of the features of the BSL and its implementation, see the *MSP430™ Flash Device Bootloader (BSL) User's Guide*.

Table 6-6. UART BSL Pin Requirements and Functions

DEVICE SIGNAL	BSL FUNCTION
$\overline{\text{RST}}/\text{NMI}/\text{SBWTDIO}$	Entry sequence signal
$\text{TEST}/\text{SBWTCK}$	Entry sequence signal
P2.0	Data transmit
P2.1	Data receive
DVCC	Power supply
DVSS	Ground supply

6.9 JTAG Operation

6.9.1 JTAG Standard Interface

The MSP430 family supports the standard JTAG interface which requires four signals for sending and receiving data. The JTAG signals are shared with general-purpose I/O. The TEST/SBWTCK pin is used to enable the JTAG signals. In addition to these signals, the $\overline{\text{RST}}/\text{NMI}/\text{SBWTDIO}$ is required to interface with MSP430 development tools and device programmers. [Table 6-7](#) lists the JTAG interface pin requirements. For further details on interfacing to development tools and device programmers, see the [MSP430 Hardware Tools User's Guide](#). For a complete description of the features of the JTAG interface and its implementation, see [MSP430 Programming With the JTAG Interface](#).

Table 6-7. JTAG Pin Requirements and Functions

DEVICE SIGNAL	DIRECTION	FUNCTION
PJ.3/TCK	IN	JTAG clock input
PJ.2/TMS	IN	JTAG state control
PJ.1/TDI/TCLK	IN	JTAG data input, TCLK input
PJ.0/TDO	OUT	JTAG data output
TEST/SBWTCK	IN	Enable JTAG pins
$\overline{\text{RST}}/\text{NMI}/\text{SBWTDIO}$	IN	External reset
DVCC		Power supply
DVSS		Ground supply

6.9.2 Spy-Bi-Wire Interface

In addition to the standard JTAG interface, the MSP430 family supports the 2-wire Spy-Bi-Wire interface. Spy-Bi-Wire can be used to interface with MSP430 development tools and device programmers. [Table 6-8](#) lists the Spy-Bi-Wire interface pin requirements. For further details on interfacing to development tools and device programmers, see the [MSP430 Hardware Tools User's Guide](#). For a complete description of the features of the JTAG interface and its implementation, see [MSP430 Programming With the JTAG Interface](#).

Table 6-8. Spy-Bi-Wire Pin Requirements and Functions

DEVICE SIGNAL	DIRECTION	FUNCTION
TEST/SBWTCK	IN	Spy-Bi-Wire clock input
$\overline{\text{RST}}/\text{NMI}/\text{SBWTDIO}$	IN, OUT	Spy-Bi-Wire data input and output
DVCC		Power supply
DVSS		Ground supply

6.10 Memory

6.10.1 Memory Organization

Table 6-9 summarizes the memory map of the MSP430F67x9A, MSP430F67x8A, and MSP430F67x7A devices.

Table 6-9. Memory Organization – MSP430F67x9A, MSP430F67x8A, and MSP430F67x7A

		MSP430F6779A MSP430F6769A MSP430F6749A	MSP430F6778A MSP430F6768A MSP430F6748A	MSP430F6777A MSP430F6767A MSP430F6747A
Main memory (flash)	Total Size	512KB	512KB	256KB
Main: interrupt vector		00FFFFh to 00FF80h	00FFFFh to 00FF80h	00FFFFh to 00FF80h
Main: code memory	Bank 3	128KB 08BFFFh to 06C000h	128KB 08BFFFh to 06C000h	Not available
	Bank 2	128KB 06BFFFh to 04C000h	128KB 06BFFFh to 04C000h	Not available
	Bank 1	128KB 04BFFFh to 02C000h	128KB 04BFFFh to 02C000h	128KB 04BFFFh to 02C000h
	Bank 0	128KB 02BFFFh to 00C000h	128KB 02BFFFh to 00C000h	128KB 02BFFFh to 00C000h
RAM	Total Size	32KB	16KB	32KB
	Sector 7	4KB 009BFFh to 008C00h	Not available	4KB 009BFFh to 008C00h
	Sector 6	4KB 008BFFh to 007C00h	Not available	4KB 008BFFh to 007C00h
	Sector 5	4KB 007BFFh to 006C00h	Not available	4KB 007BFFh to 006C00h
	Sector 4	4KB 006BFFh to 005C00h	Not available	4KB 006BFFh to 005C00h
	Sector 3	4KB 005BFFh to 004C00h	4KB 005BFFh to 004C00h	4KB 005BFFh to 004C00h
	Sector 2	4KB 004BFFh to 003C00h	4KB 004BFFh to 003C00h	4KB 004BFFh to 003C00h
	Sector 1	4KB 003BFFh to 002C00h	4KB 003BFFh to 002C00h	4KB 003BFFh to 002C00h
	Sector 0	4KB 002BFFh to 001C00h	4KB 002BFFh to 001C00h	4KB 002BFFh to 001C00h
Device descriptor		128 B 001AFFh to 001A80h	128 B 001AFFh to 001A80h	128 B 001AFFh to 001A80h
		128 B 001A7Fh to 001A00h	128 B 001A7Fh to 001A00h	128 B 001A7Fh to 001A00h
Information memory (flash)	Info A	128 B 0019FFh to 001980h	128 B 0019FFh to 001980h	128 B 0019FFh to 001980h
	Info B	128 B 00197Fh to 001900h	128 B 00197Fh to 001900h	128 B 00197Fh to 001900h
	Info C	128 B 0018FFh to 001880h	128 B 0018FFh to 001880h	128 B 0018FFh to 001880h
	Info D	128 B 00187Fh to 001800h	128 B 00187Fh to 001800h	128 B 00187Fh to 001800h
Bootloader (BSL) memory (flash)	BSL 3	512 B 0017FFh to 001600h	512 B 0017FFh to 001600h	512 B 0017FFh to 001600h
	BSL 2	512 B 0015FFh to 001400h	512 B 0015FFh to 001400h	512 B 0015FFh to 001400h
	BSL 1	512 B 0013FFh to 001200h	512 B 0013FFh to 001200h	512 B 0013FFh to 001200h
	BSL 0	512 B 0011FFh to 001000h	512 B 0011FFh to 001000h	512 B 0011FFh to 001000h

Table 6-9. Memory Organization – MSP430F67x9A, MSP430F67x8A, and MSP430F67x7A (continued)

		MSP430F6779A MSP430F6769A MSP430F6749A	MSP430F6778A MSP430F6768A MSP430F6748A	MSP430F6777A MSP430F6767A MSP430F6747A
Peripherals		4KB 000FFFh to 0h	4KB 000FFFh to 0h	4KB 000FFFh to 0h

Table 6-10 summarizes the memory map of the MSP430F67x6A and MSP430F67x5A devices.

Table 6-10. Memory Organization – MSP430F67x6A and MSP430F67x5A

		MSP430F6776A MSP430F6766A MSP430F6746A	MSP430F6775A MSP430F6765A MSP430F6745A
Main memory (flash)	Total Size	256KB	128KB
Main: interrupt vector		00FFFFh to 00FF80h	00FFFFh to 00FF80h
Main: code memory	Bank 3	Not available	Not available
	Bank 2	Not available	Not available
	Bank 1	128KB 04BFFFh to 02C000h	Not available
	Bank 0	128KB 02BFFFh to 00C000h	128KB 02BFFFh to 00C000h
RAM	Total Size	16KB	16KB
	Sector 7	Not available	Not available
	Sector 6	Not available	Not available
	Sector 5	Not available	Not available
	Sector 4	Not available	Not available
	Sector 3	4KB 005BFFFh to 004C00h	4KB 005BFFFh to 004C00h
	Sector 2	4KB 004BFFFh to 003C00h	4KB 004BFFFh to 003C00h
	Sector 1	4KB 003BFFFh to 002C00h	4KB 003BFFFh to 002C00h
Device descriptor		128 B 001AFFh to 001A80h	128 B 001AFFh to 001A80h
		128 B 001A7Fh to 001A00h	128 B 001A7Fh to 001A00h
Information memory (flash)	Info A	128 B 0019FFh to 001980h	128 B 0019FFh to 001980h
	Info B	128 B 00197Fh to 001900h	128 B 00197Fh to 001900h
	Info C	128 B 0018FFh to 001880h	128 B 0018FFh to 001880h
	Info D	128 B 00187Fh to 001800h	128 B 00187Fh to 001800h
Bootloader (BSL) memory (flash)	BSL 3	512 B 0017FFh to 001600h	512 B 0017FFh to 001600h
	BSL 2	512 B 0015FFh to 001400h	512 B 0015FFh to 001400h
	BSL 1	512 B 0013FFh to 001200h	512 B 0013FFh to 001200h
	BSL 0	512 B 0011FFh to 001000h	512 B 0011FFh to 001000h
Peripherals		4KB 000FFFh to 0h	4KB 000FFFh to 0h

6.10.2 Flash Memory ([Link to User's Guide](#))

The flash memory can be programmed through the JTAG port, Spy-Bi-Wire (SBW), the BSL, or in-system by the CPU. The CPU can perform single-byte, single-word, and long-word writes to the flash memory. Features of the flash memory include:

- Flash memory has n segments of main memory and four segments of information memory (A to D) of 128 bytes each. Each segment in main memory is 512 bytes in size.
- Segments 0 to n may be erased in one step, or each segment may be individually erased.
- Segments A to D can be erased individually, or as a group with segments 0 to n. Segments A to D are also called *information memory*.
- Segment A can be locked separately.

6.10.3 RAM ([Link to User's Guide](#))

The RAM is made up of n sectors. Each sector can be completely powered down to save leakage; however, all data are lost in the sector that is powered down. Features of the RAM include:

- RAM has n sectors of 4KB each.
- Each sector 0 to n can be completely disabled; however, data retention is lost in the disabled sector.
- Each sector 0 to n automatically enters low-power retention mode when possible.

6.10.4 Backup RAM ([Link to User's Guide](#))

The backup RAM provides a limited number of bytes of RAM that are retained during LPM3.5. This backup RAM is part of the backup subsystem that operates on dedicated power supply AUXVCC3. Eight bytes of backup RAM are available in this device. The backup RAM can be word-wise accessed using the registers BAKMEM0, BAKMEM1, BAKMEM2, and BAKMEM3. The backup RAM registers cannot be accessed by CPU when the high-side SVS is disabled by the user application.

6.11 Peripherals

Peripherals are connected to the CPU through data, address, and control buses. Peripherals can be controlled using all instructions. For complete module descriptions, see the [MSP430x5xx and MSP430x6xx Family User's Guide](#).

6.11.1 Oscillator and System Clock ([Link to User's Guide](#))

The Unified Clock System (UCS) module includes support for a 32768-Hz watch crystal oscillator, an internal very-low-power low-frequency oscillator (VLO), an internal trimmed low-frequency oscillator (REFO), and an integrated internal digitally controlled oscillator (DCO). The UCS module is designed to meet the requirements of both low system cost and low power consumption. The UCS module features digital frequency-locked loop (FLL) hardware that, in conjunction with a digital modulator, stabilizes the DCO frequency to a programmable multiple of the selected FLL reference frequency. The internal DCO provides a fast turnon clock source and stabilizes in less than 5 μ s. The UCS module provides the following clock signals:

- Auxiliary clock (ACLK), sourced from a 32768-Hz watch crystal, the internal low-frequency oscillator (VLO), or the trimmed low-frequency oscillator (REFO).
- Main clock (MCLK), the system clock used by the CPU. MCLK can be sourced by same sources made available to ACLK.
- Sub-Main clock (SMCLK), the subsystem clock used by the peripheral modules. SMCLK can be sourced by same sources made available to ACLK.
- ACLK/n, the buffered output of ACLK, ACLK/2, ACLK/4, ACLK/8, ACLK/16, ACLK/32.

6.11.2 Power-Management Module (PMM) ([Link to User's Guide](#))

The PMM includes an integrated voltage regulator that supplies the core voltage to the device and contains programmable output levels to provide for power optimization. The PMM also includes supply voltage supervisor (SVS) and supply voltage monitoring (SVM) circuitry, as well as brownout protection. The brownout circuit is implemented to provide the proper internal reset signal to the device during power on and power off. The SVS and SVM circuitry detects if the supply voltage drops below a user-selectable level and supports both supply voltage supervision (the device is automatically reset) and supply voltage monitoring (the device is not automatically reset). SVS and SVM circuitry is available on the primary supply and core supply.

6.11.3 Auxiliary-Supply System ([Link to User's Guide](#))

The auxiliary supply system provides the option to operate the device from auxiliary supplies when the primary supply fails. There are two auxiliary supplies (AUXVCC1 and AUXVCC2) supported in MSP430F67xx. This module supports automatic and manual switching from primary supply to auxiliary supplies while maintaining full functionality. The auxiliary supply system allows threshold-based monitoring of primary and auxiliary supplies. The device can be started from primary supply or AUXVCC1, whichever is higher. Auxiliary supply system enables internal monitoring of voltage levels on primary and auxiliary supplies using ADC10_A. This module also implements a simple charger for backup capacitors.

6.11.4 Backup Subsystem

The backup subsystem operates on a dedicated power supply AUXVCC3. This subsystem includes low-frequency oscillator, real-time clock module, and backup RAM. The functionality of the backup subsystem is retained during LPM3.5. The backup subsystem module registers cannot be accessed by CPU when the high-side SVS is disabled by user.

6.11.5 Digital I/O ([Link to User's Guide](#))

Up to eleven 8-bit I/O ports are implemented. For 128-pin options, ports P1 to P10 are complete, and port P11 is 6 bits wide. For 100-pin options, ports P1 to P7 are complete, port P8 is 2 bits wide, and ports P9, P10, and P11 are completely removed. Port PJ contains four individual I/O pins, common to all devices. All I/O bits are individually programmable.

- Any combination of input, output, and interrupt conditions is possible.
- Programmable pullup or pulldown on all ports.
- Programmable drive strength on all ports.
- Edge-selectable interrupt and LPM3.5, LPM4.5 wake-up input capability available for all bits of ports P1 and P2.
- Read-write access to port-control registers is supported by all instructions.
- Ports can be accessed byte-wise (P1 to P11) or word-wise in pairs (PA to PF).

6.11.6 Port Mapping Controller ([Link to User's Guide](#))

The port mapping controller allows flexible and reconfigurable mapping of digital functions to ports P2, P3, and P4 (see [Table 6-11](#)). [Table 6-12](#) lists the default settings for all pins that support port mapping.

Table 6-11. Port Mapping Mnemonics and Functions

VALUE	PxMAPy MNEMONIC	INPUT PIN FUNCTION	OUTPUT PIN FUNCTION
0	PM_NONE	None	DVSS
1	PM_UCA0RXD	eUSCI_A0 UART RXD (direction controlled by eUSCI – Input)	
	PM_UCA0SOMI	eUSCI_A0 SPI slave out master in (direction controlled by eUSCI)	
2	PM_UCA0TXD	eUSCI_A0 UART TXD (direction controlled by eUSCI – Output)	
	PM_UCA0SIMO	eUSCI_A0 SPI slave in master out (direction controlled by eUSCI)	
3	PM_UCA0CLK	eUSCI_A0 clock input/output (direction controlled by eUSCI)	
4	PM_UCA0STE	eUSCI_A0 SPI slave transmit enable (direction controlled by eUSCI)	
5	PM_UCA1RXD	eUSCI_A1 UART RXD (direction controlled by eUSCI – Input)	
	PM_UCA1SOMI	eUSCI_A1 SPI slave out master in (direction controlled by eUSCI)	
6	PM_UCA1TXD	eUSCI_A1 UART TXD (direction controlled by eUSCI – Output)	
	PM_UCA1SIMO	eUSCI_A1 SPI slave in master out (direction controlled by eUSCI)	
7	PM_UCA1CLK	eUSCI_A1 clock input/output (direction controlled by eUSCI)	
8	PM_UCA1STE	eUSCI_A1 SPI slave transmit enable (direction controlled by eUSCI)	
9	PM_UCA2RXD	eUSCI_A2 UART RXD (direction controlled by eUSCI – Input)	
	PM_UCA2SOMI	eUSCI_A2 SPI slave out master in (direction controlled by eUSCI)	
10	PM_UCA2TXD	eUSCI_A2 UART TXD (direction controlled by eUSCI – Output)	
	PM_UCA2SIMO	eUSCI_A2 SPI slave in master out (direction controlled by eUSCI)	
11	PM_UCA2CLK	eUSCI_A2 clock input/output (direction controlled by eUSCI)	
12	PM_UCA2STE	eUSCI_A2 SPI slave transmit enable (direction controlled by eUSCI)	
13	PM_UCA3RXD	eUSCI_A3 UART RXD (direction controlled by eUSCI – Input)	
	PM_UCA3SOMI	eUSCI_A3 SPI slave out master in (direction controlled by eUSCI)	
14	PM_UCA3TXD	eUSCI_A3 UART TXD (direction controlled by eUSCI – Output)	
	PM_UCA3SIMO	eUSCI_A3 SPI slave in master out (direction controlled by eUSCI)	
15	PM_UCA3CLK	eUSCI_A3 clock input/output (direction controlled by eUSCI)	
16	PM_UCA3STE	eUSCI_A3 SPI slave transmit enable (direction controlled by eUSCI)	
17	PM_UCB0SIMO	eUSCI_B0 SPI slave in master out (direction controlled by eUSCI)	
	PM_UCB0SDA	eUSCI_B0 I2C data (open drain and direction controlled by eUSCI)	
18	PM_UCB0SOMI	eUSCI_B0 SPI slave out master in (direction controlled by eUSCI)	
	PM_UCB0SCL	eUSCI_B0 I2C clock (open drain and direction controlled by eUSCI)	
19	PM_UCB0CLK	eUSCI_B0 clock input/output (direction controlled by eUSCI)	
20	PM_UCB0STE	eUSCI_B0 SPI slave transmit enable (direction controlled by eUSCI)	

Table 6-11. Port Mapping Mnemonics and Functions (continued)

VALUE	PxMAPy MNEMONIC	INPUT PIN FUNCTION	OUTPUT PIN FUNCTION
21	PM_UCB1SIMO	eUSCI_B1 SPI slave in master out (direction controlled by eUSCI)	
	PM_UCB1SDA	eUSCI_B1 I2C data (open drain and direction controlled by eUSCI)	
22	PM_UCB1SOMI	eUSCI_B1 SPI slave out master in (direction controlled by eUSCI)	
	PM_UCB1SCL	eUSCI_B1 I2C clock (open drain and direction controlled by eUSCI)	
23	PM_UCB1CLK	eUSCI_B1 clock input/output (direction controlled by eUSCI)	
24	PM_UCB1STE	eUSCI_B1 SPI slave transmit enable (direction controlled by eUSCI)	
25	PM_TA0.0	TA0 CCR0 capture input CCI0A	TA0 CCR0 compare output Out0
26	PM_TA0.1	TA0 CCR1 capture input CCI1A	TA0 CCR1 compare output Out1
27	PM_TA0.2	TA0 CCR2 capture input CCI2A	TA0 CCR2 compare output Out2
28	PM_TA1.0	TA1 CCR0 capture input CCI0A	TA1 CCR0 compare output Out0
29	PM_TA2.0	TA2 CCR0 capture input CCI0A	TA2 CCR0 compare output Out0
30	PM_TA3.0	TA3 CCR0 capture input CCI0A	TA3 CCR0 compare output Out0
31 (0FFh) ⁽¹⁾	PM_ANALOG	Disables the output driver and the input Schmitt trigger to prevent parasitic cross currents when applying analog signals.	

(1) The value of the PM_ANALOG mnemonic is set to 0FFh. The port mapping registers are only 5 bits wide, and the upper bits are ignored, which results in a read value of 31.

Table 6-12. Default Port Mapping

PIN NAME		PxMAPy MNEMONIC	INPUT PIN FUNCTION	OUTPUT PIN FUNCTION
PEU	PZ			
P2.0/PM_TA0.0	P2.0/PM_TA0.0/COM4	PM_TA0.0	TA0 CCR0 capture input CCI0A	TA0 CCR0 compare output Out0
P2.1/PM_TA0.1	P2.1/PM_TA0.1/COM5	PM_TA0.1	TA0 CCR1 capture input CCI1A	TA0 CCR1 compare output Out1
P2.2/PM_TA0.2	P2.2/PM_TA0.2/COM6	PM_TA0.2	TA0 CCR2 capture input CCI2A	TA0 CCR2 compare output Out2
P2.3/PM_TA1.0	P2.3/PM_TA1.0/COM7	PM_TA1.0	TA1 CCR0 capture input CCI0A	TA1 CCR0 compare output Out0
P2.4/PM_TA2.0	P1.1/PM_TA2.0/R23	PM_TA2.0	TA2 CCR0 capture input CCI0A	TA2 CCR0 compare output Out0
P2.5/PM_UCB0SOMI/ PM_UCB0SCL	P2.0/PM_UCB0SOMI/ PM_UCB0SCL/R13	PM_UCB0SOMI/ PM_UCB0SCL	eUSCI_B0 SPI slave out master in (direction controlled by eUSCI), eUSCI_B0 I2C clock (open drain and direction controlled by eUSCI)	
P2.6/PM_UCB0SIMO/ PM_UCB0SDA	P2.6/PM_UCB0SIMO/ PM_UCB0SDA/R03	PM_UCB0SIMO/ PM_UCB0SDA	eUSCI_B0 SPI slave in master out (direction controlled by eUSCI), eUSCI_B0 I2C data (open drain and direction controlled by eUSCI)	
P2.7/PM_UCB0CLK	P2.7/PM_UCB0CLK/CB2	PM_UCB0CLK	eUSCI_B0 clock input/output (direction controlled by eUSCI)	
P3.0/PM_UCA0RXD/ PM_UCA0SOMI	P3.0/PM_UCA0RXD/ PM_UCA0SOMI	PM_UCA0RXD/ PM_UCA0SOMI	eUSCI_A0 UART RXD (direction controlled by eUSCI – input), eUSCI_A0 SPI slave out master in (direction controlled by eUSCI)	
P3.1/PM_UCA0TXD/ PM_UCA0SIMO	P3.1/PM_UCA0TXD/ PM_UCA0SIMO/S39	PM_UCA0TXD/ PM_UCA0SIMO	eUSCI_A0 UART TXD (direction controlled by eUSCI – output), eUSCI_A0 SPI slave in master out (direction controlled by eUSCI)	
P3.2/PM_UCA0CLK	P3.2/PM_UCA0CLK/S38	PM_UCA0CLK	eUSCI_A0 clock input/output (direction controlled by eUSCI)	
P3.3/PM_UCA1CLK	P3.3/PM_UCA1CLK/S37	PM_UCA1CLK	eUSCI_A1 clock input/output (direction controlled by eUSCI)	
P3.4/PM_UCA1RXD/ PM_UCA1SOMI/	P3.4/PM_UCA1RXD/ PM_UCA1SOMI/S36	PM_UCA1RXD/ PM_UCA1SOMI	eUSCI_A1 UART RXD (direction controlled by eUSCI – input), eUSCI_A1 SPI slave out master in (direction controlled by eUSCI)	
P3.5/PM_UCA1TXD/ PM_UCA1SIMO	P3.5/PM_UCA1TXD/ PM_UCA1SIMO/S35	PM_UCA1TXD/ PM_UCA1SIMO	eUSCI_A1 UART TXD (direction controlled by eUSCI – output), eUSCI_A1 SPI slave in master out (direction controlled by eUSCI)	
P3.6/PM_UCA2RXD/ PM_UCA2SOMI/	P3.6/PM_UCA2RXD/ PM_UCA2SOMI/S34	PM_UCA2RXD/ PM_UCA2SOMI	eUSCI_A2 UART RXD (direction controlled by eUSCI – input), eUSCI_A2 SPI slave out master in (direction controlled by eUSCI)	
P3.7/PM_UCA2TXD/ PM_UCA2SIMO	P3.7/PM_UCA2TXD/ PM_UCA2SIMO/S33	PM_UCA2TXD/ PM_UCA2SIMO	eUSCI_A2 UART TXD (direction controlled by eUSCI – output), eUSCI_A2 SPI slave in master out (direction controlled by eUSCI)	
P4.0/PM_UCA2CLK	P4.0/PM_UCA2CLK/S32	PM_UCA2CLK	eUSCI_A2 clock input/output (direction controlled by eUSCI)	
P4.1/PM_UCA3RXD/ PM_UCA3SOMI/	P4.1/PM_UCA3RXD/ PM_UCA3SOMI/S31	PM_UCA3RXD/ PM_UCA3SOMI	eUSCI_A3 UART RXD (direction controlled by eUSCI – input), eUSCI_A3 SPI slave out master in (direction controlled by eUSCI)	
P4.2/PM_UCA3TXD/ PM_UCA3SIMO	P4.2/PM_UCA3TXD/ PM_UCA3SIMO/S30	PM_UCA3TXD/ PM_UCA3SIMO	eUSCI_A3 UART TXD (direction controlled by eUSCI – output), eUSCI_A3 SPI slave in master out (direction controlled by eUSCI)	
P4.3/PM_UCA3CLK	P4.3/PM_UCA3CLK/S29	PM_UCA3CLK	eUSCI_A3 clock input/output (direction controlled by eUSCI)	
P4.4/PM_UCB1SOMI/ PM_UCB1SCL	P4.4/PM_UCB1SOMI/ PM_UCB1SCL/S28	PM_UCB1SOMI/ PM_UCB1SCL	eUSCI_B1 SPI slave out master in (direction controlled by eUSCI), eUSCI_B1 I2C clock (open drain and direction controlled by eUSCI)	
P4.5/PM_UCB1SIMO/ PM_UCB1SDA	P4.5/PM_UCB1SIMO/ PM_UCB1SDA/S27	PM_UCB1SIMO/ PM_UCB1SDA	eUSCI_B1 SPI slave in master out (direction controlled by eUSCI), eUSCI_B1 I2C data (open drain and direction controlled by eUSCI)	
P4.6/PM_UCB1CLK	P4.6/PM_UCB1CLK/S26	PM_UCB1CLK	eUSCI_B1 clock input/output (direction controlled by eUSCI)	
P4.7/PM_TA3.0	P4.7/PM_TA3.0/S25	PM_TA3.0	TA3 CCR0 capture input CCI0A	TA3 CCR0 compare output Out0

6.11.7 System Module (SYS) [\(Link to User's Guide\)](#)

The SYS module handles many of the system functions within the device. These include power-on reset (POR) and power-up clear (PUC) handling, NMI source selection and management, reset interrupt vector generators, bootloader entry mechanisms, and configuration management (device descriptors). The SYS module also includes a data exchange mechanism using JTAG called a JTAG mailbox that can be used in the application. [Table 6-13](#) lists the SYS module interrupt vector registers.

Table 6-13. System Module Interrupt Vector Registers

INTERRUPT VECTOR REGISTER	ADDRESS	INTERRUPT EVENT	VALUE	PRIORITY
SYSRSTIV, System Reset	019Eh	No interrupt pending	00h	
		Brownout (BOR)	02h	Highest
		RST/NMI (POR)	04h	
		DoBOR (BOR)	06h	
		Wake up from LPMx.5	08h	
		Security violation (BOR)	0Ah	
		SVSL (POR)	0Ch	
		SVSH (POR)	0Eh	
		SVML_OVP (POR)	10h	
		SVMH_OVP (POR)	12h	
		DoPOR (POR)	14h	
		WDT time-out (PUC)	16h	
		WDT key violation (PUC)	18h	
		KEYV flash key violation (PUC)	1Ah	
		Reserved	1Ch	
		Peripheral area fetch (PUC)	1Eh	
		PMM key violation (PUC)	20h	
Reserved	22h to 3Eh	Lowest		
SYSSNIV, System NMI	019Ch	No interrupt pending	00h	
		SVMLIFG	02h	Highest
		SVMHIFG	04h	
		DLYLIFG	06h	
		DLYHIFG	08h	
		VMAIFG	0Ah	
		JMBINIFG	0Ch	
		JMBOUTIFG	0Eh	
		VLRLIFG	10h	
		VLRHIFG	12h	
		Reserved	14h to 1Eh	Lowest
		SYSUNIV, User NMI	019Ah	No interrupt pending
NMIIFG	02h			Highest
OFIFG	04h			
ACCVIFG	06h			
AUXSWGIFG	08h			
Reserved	0Ah to 1Eh			Lowest

6.11.8 Watchdog Timer (WDT_A) [\(Link to User's Guide\)](#)

The primary function of the WDT_A is to perform a controlled system restart after a software problem occurs. If the selected time interval expires, a system reset is generated. If the watchdog function is not needed in an application, the timer can be configured as an interval timer and can generate interrupts at selected time intervals.

6.11.9 DMA Controller ([Link to User's Guide](#))

The DMA controller allows movement of data from one memory address to another without CPU intervention. For example, the DMA controller can be used to move data from the ADC10_A conversion memory to RAM. Using the DMA controller can increase the throughput of peripheral modules. The DMA controller reduces system power consumption by allowing the CPU to remain in sleep mode, without having to awaken to move data to or from a peripheral. [Table 6-14](#) lists the available DMA triggers.

Table 6-14. DMA Trigger Assignments⁽¹⁾

TRIGGER	CHANNEL		
	0	1	2
0	DMAREQ	DMAREQ	DMAREQ
1	TA0CCR0 CCIFG	TA0CCR0 CCIFG	TA0CCR0 CCIFG
2	TA0CCR2 CCIFG	TA0CCR2 CCIFG	TA0CCR2 CCIFG
3	TA1CCR0 CCIFG	TA1CCR0 CCIFG	TA1CCR0 CCIFG
4	Reserved	Reserved	Reserved
5	TA2CCR0 CCIFG	TA2CCR0 CCIFG	TA2CCR0 CCIFG
6	Reserved	Reserved	Reserved
7	TA3CCR0 CCIFG	TA3CCR0 CCIFG	TA3CCR0 CCIFG
8	Reserved	Reserved	Reserved
9	Reserved	Reserved	Reserved
10	Reserved	Reserved	Reserved
11	Reserved	Reserved	Reserved
12	Reserved	Reserved	Reserved
13	SD24IFG	SD24IFG	SD24IFG
14	Reserved	Reserved	Reserved
15	Reserved	Reserved	Reserved
16	UCA0RXIFG	UCA0RXIFG	UCA0RXIFG
17	UCA0TXIFG	UCA0TXIFG	UCA0TXIFG
18	UCA1RXIFG	UCA1RXIFG	UCA1RXIFG
19	UCA1TXIFG	UCA1TXIFG	UCA1TXIFG
20	UCA2RXIFG	UCA2RXIFG	UCA2RXIFG
21	UCA2TXIFG	UCA2TXIFG	UCA2TXIFG
22	UCB0RXIFG0	UCB0RXIFG0	UCB0RXIFG0
23	UCB0TXIFG0	UCB0TXIFG0	UCB0TXIFG0
24	ADC10IFG0	ADC10IFG0	ADC10IFG0
25	UCA3RXIFG	UCA3RXIFG	UCA3RXIFG
26	UCA3TXIFG	UCA3TXIFG	UCA3TXIFG
27	UCB1RXIFG0	UCB1RXIFG0	UCB1RXIFG0
28	UCB1TXIFG0	UCB1TXIFG0	UCB1TXIFG0
29	MPY ready	MPY ready	MPY ready
30	DMA2IFG	DMA0IFG	DMA1IFG
31	Reserved	Reserved	Reserved

(1) Reserved DMA triggers may be used by other devices in the family. Reserved DMA triggers do not cause any DMA trigger event when selected.

6.11.10 CRC16 ([Link to User's Guide](#))

The CRC16 module produces a signature based on a sequence of entered data values and can be used for data checking purposes. The CRC16 module signature is based on the CRC-CCITT standard.

6.11.11 Hardware Multiplier ([Link to User's Guide](#))

The multiplication operation is supported by a dedicated peripheral module. The module performs operations with 32-, 24-, 16-, and 8-bit operands. The module supports signed and unsigned multiplication as well as signed and unsigned multiply-and-accumulate operations.

6.11.12 AES128 Accelerator ([Link to User's Guide](#))

The AES accelerator module performs encryption and decryption of 128-bit data with 128-bit keys according to the Advanced Encryption Standard (AES) (FIPS PUB 197) in hardware.

6.11.13 Enhanced Universal Serial Communication Interface (eUSCI) ([Links to User's Guide: UART Mode, SPI Mode, I²C Mode](#))

The eUSCI module is used for serial data communication. The eUSCI module supports synchronous communication protocols such as SPI (3- or 4-pin) and I²C, and asynchronous communication protocols such as UART, enhanced UART with automatic baud-rate detection, and IrDA.

The eUSCI_An module provides support for SPI (3- or 4-pin), UART, enhanced UART, and IrDA.

The eUSCI_Bn module provides support for SPI (3- or 4-pin) and I²C.

Four eUSCI_A and two eUSCI_B module are implemented in the MSP430F67xxA MCUs.

6.11.14 ADC10_A ([Link to User's Guide](#))

The ADC10_A module supports fast, 10-bit analog-to-digital conversions. The module implements a 10-bit SAR core, sample select control, reference generator and a conversion results buffer. A window comparator with a lower and upper limit allows CPU independent result monitoring with three window comparator interrupt flags.

6.11.15 SD24_B ([Link to User's Guide](#))

The SD24_B module integrates up to seven independent 24-bit sigma-delta ADCs. Each converter is designed with a fully differential analog input pair and programmable gain amplifier input stage. Also the converters are based on second-order oversampling sigma-delta modulators and digital decimation filters. The decimation filters are comb filters with selectable oversampling ratios of up to 1024.

6.11.16 TA0 [\(Link to User's Guide\)](#)

TA0 is a 16-bit timer/counter (Timer_A type) with three capture/compare registers. TA0 can support multiple capture/compares, PWM outputs, and interval timing (see [Table 6-15](#)). TA0 also has extensive interrupt capabilities. Interrupts may be generated from the counter on overflow conditions and from each of the capture/compare registers.

Table 6-15. TA0 Signal Connections

DEVICE INPUT SIGNAL	MODULE INPUT NAME	MODULE BLOCK	MODULE OUTPUT SIGNAL	DEVICE OUTPUT SIGNAL
PM_TACLK	TACLK	Timer	NA	NA
ACLK (internal)	ACLK			
SMCLK (internal)	SMCLK			
PM_TACLK	INCLK			
PM_TA0.0	CCI0A	CCR0	TA0	PM_TA0.0
CBOU (internal)	CCI0B			
DVSS	GND			
DVCC	VCC			
PM_TA0.1	CCI1A	CCR1	TA1	PM_TA0.1
ACLK (internal)	CCI1B			
DVSS	GND			
DVCC	VCC			
PM_TA0.2	CCI2A	CCR2	TA2	PM_TA0.2
DVSS	CCI2B			
DVSS	GND			
DVCC	VCC			

6.11.17 TA1 [\(Link to User's Guide\)](#)

TA1 is a 16-bit timer/counter (Timer_A type) with two capture/compare registers (see [Table 6-16](#)). TA1 can support multiple capture/compares, PWM outputs, and interval timing. TA1 also has extensive interrupt capabilities. Interrupts may be generated from the counter on overflow conditions and from each of the capture/compare registers.

Table 6-16. TA1 Signal Connections

DEVICE INPUT SIGNAL	MODULE INPUT NAME	MODULE BLOCK	MODULE OUTPUT SIGNAL	DEVICE OUTPUT SIGNAL
PM_TACLK	TACLK	Timer	NA	NA
ACLK (internal)	ACLK			
SMCLK (internal)	SMCLK			
PM_TACLK	INCLK			
PM_TA1.0	CCI0A	CCR0	TA0	PM_TA1.0
CBOU (internal)	CCI0B			
DVSS	GND			
DVCC	VCC			
PM_TA1.1	CCI1A	CCR1	TA1	PM_TA1.1
ACLK (internal)	CCI1B			
DVSS	GND			
DVCC	VCC			

6.11.18 TA2 [\(Link to User's Guide\)](#)

TA2 is a 16-bit timer/counter (Timer_A type) with two capture/compare registers. TA2 can support multiple capture/compares, PWM outputs, and interval timing (see [Table 6-17](#)). TA2 also has extensive interrupt capabilities. Interrupts may be generated from the counter on overflow conditions and from each of the capture/compare registers.

Table 6-17. TA2 Signal Connections

DEVICE INPUT SIGNAL	MODULE INPUT NAME	MODULE BLOCK	MODULE OUTPUT SIGNAL	DEVICE OUTPUT SIGNAL
PM_TACLK	TACLK	Timer	NA	NA
ACLK (internal)	ACLK			
SMCLK (internal)	SMCLK			
PM_TACLK	INCLK			
PM_TA2.0	CCI0A	CCR0	TA0	PM_TA2.0
CBOUT (internal)	CCI0B			
DVSS	GND			
DVCC	VCC			
PM_TA2.1	CCI1A	CCR1	TA1	PM_TA2.1
ACLK (internal)	CCI1B			
DVSS	GND			
DVCC	VCC			

6.11.19 TA3 [\(Link to User's Guide\)](#)

TA3 is a 16-bit timer/counter (Timer_A type) with two capture/compare registers. TA3 can support multiple capture/compares, PWM outputs, and interval timing (see [Table 6-18](#)). TA3 also has extensive interrupt capabilities. Interrupts may be generated from the counter on overflow conditions and from each of the capture/compare registers.

Table 6-18. TA3 Signal Connections

DEVICE INPUT SIGNAL	MODULE INPUT NAME	MODULE BLOCK	MODULE OUTPUT SIGNAL	DEVICE OUTPUT SIGNAL
PM_TACLK	TACLK	Timer	NA	
ACLK (internal)	ACLK			
SMCLK (internal)	SMCLK			
PM_TACLK	INCLK			
PM_TA3.0	CCI0A	CCR0	TA0	PM_TA3.0
CBOUT (internal)	CCI0B			
DVSS	GND			
DVCC	VCC			
PM_TA3.1	CCI1A	CCR1	TA1	PM_TA3.1
ACLK (internal)	CCI1B			
DVSS	GND			
DVCC	VCC			

6.11.20 SD24_B Triggers

Table 6-19 lists the input trigger connections to SD24_B converters from Timer_A modules and output trigger pulse connection from SD24_B to ADC10_A.

Table 6-19. SD24_B Input/Output Trigger Connections

DEVICE INPUT SIGNAL	MODULE INPUT SIGNAL	MODULE BLOCK	MODULE OUTPUT SIGNAL	DEVICE OUTPUT SIGNAL
TA0.1 (internal)	SD24_B SD24CHx.SD24SCSx = 001b	SD24_B	Trigger Pulse	ADC10_A (internal) ADC10SHSx = 011b
TA2.1 (internal)	SD24_B SD24CHx.SD24SCSx = 010b			
TA3.1 (internal)	SD24_B SD24CHx.SD24SCSx = 011b			

6.11.21 ADC10_A Triggers

Table 6-20 lists the input trigger connections to ADC10_A from Timer_A modules and SD24_B.

Table 6-20. ADC10_A Input Trigger Connections

DEVICE INPUT SIGNAL	MODULE INPUT SIGNAL	MODULE BLOCK
TA0.1 (internal)	ADC10_A ADC10SHSx = 001b	ADC10_A
TA3.0 (internal)	ADC10_A ADC10SHSx = 010b	
SD24_B trigger pulse (internal)	ADC10_A ADC10SHSx = 011b	

6.11.22 Real-Time Clock (RTC_C) ([Link to User's Guide](#))

The RTC_C module can be configured for calendar mode providing seconds, hours, day of week, day of month, month, and year. The RTC_C control and configuration registers are password protected to ensure clock integrity against runaway code. Calendar mode integrates an internal calendar that compensates for months with less than 31 days and includes leap year correction. The RTC_C also supports flexible alarm functions, offset calibration, temperature compensation, and time capture on two external events. The RTC_C on this device operates on dedicated AUXVCC3 supply and supports operation in LPM3.5.

6.11.23 Reference (REF) Module Voltage Reference ([Link to User's Guide](#))

The REF module generates all of the critical reference voltages that can be used by the various analog peripherals in the device. The analog peripherals include the ADC10_A, LCD_C, and SD24_B modules.

6.11.24 LCD_C ([Link to User's Guide](#))

The LCD_C driver generates the segment and common signals required to drive a liquid crystal display (LCD). The LCD_C controller has dedicated data memories to hold segment drive information. Common and segment signals are generated as defined by the mode. Static, 2-mux, 3-mux, 4-mux, up to 8-mux LCDs are supported. The module can provide a LCD voltage independent of the supply voltage with its integrated charge pump. It is possible to control the level of the LCD voltage, and thus contrast, by software. The module also provides an automatic blinking capability for individual segments in static, 2-mux, 3-mux, and 4-mux modes.

6.11.25 Comparator_B ([Link to User's Guide](#))

The primary function of the Comparator_B module is to support precision slope analog-to-digital conversions, battery voltage supervision, and monitoring of external analog signals.

6.11.26 Embedded Emulation Module (EEM) [\(Link to User's Guide\)](#)

The EEM supports real-time in-system debugging. The L version of the EEM has the following features:

- Eight hardware triggers or breakpoints on memory access
- Two hardware triggers or breakpoints on CPU register write access
- Up to 10 hardware triggers that can be combined to form complex triggers or breakpoints
- Two cycle counters
- Sequencer
- State storage
- Clock control on module level

6.11.27 Peripheral File Map

Table 6-21 shows the base address for the registers of each supported peripheral. Table 6-22 through Table 6-64 show the offset addresses for each register. For complete description of these registers, see the [MSP430x5xx and MSP430x6xx Family User's Guide](#).

Table 6-21. Peripherals

MODULE NAME	BASE ADDRESS	OFFSET ADDRESS RANGE
Special Functions (see Table 6-22)	0100h	000h to 01Fh
PMM (see Table 6-23)	0120h	000h to 01Fh
Flash Control (see Table 6-24)	0140h	000h to 00Fh
CRC16 (see Table 6-25)	0150h	000h to 007h
RAM Control (see Table 6-26)	0158h	000h to 001h
Watchdog (see Table 6-27)	015Ch	000h to 001h
UCS (see Table 6-28)	0160h	000h to 01Fh
SYS (see Table 6-29)	0180h	000h to 01Fh
Shared Reference (see Table 6-30)	01B0h	000h to 001h
Port Mapping Control (see Table 6-31)	01C0h	000h to 007h
Port Mapping Port P2 (see Table 6-32)	01D0h	000h to 007h
Port Mapping Port P3 (see Table 6-33)	01D8h	000h to 007h
Port Mapping Port P4 (see Table 6-34)	01E0h	000h to 007h
Port P1, P2 (see Table 6-35)	0200h	000h to 01Fh
Port P3, P4 (see Table 6-36)	0220h	000h to 00Bh
Port P5, P6 (see Table 6-37)	0240h	000h to 00Bh
Port P7, P8 (see Table 6-38)	0260h	000h to 00Bh
Port P9, P10 (see Table 6-39) (Ports P9 and P10 not available in PZ package)	0280h	000h to 00Bh
Port P11 (see Table 6-40) (Port P11 not available in PZ package)	02A0h	000h to 00Bh
Port PJ (see Table 6-41)	0320h	000h to 01Fh
Timer TA0 (see Table 6-42)	0340h	000h to 03Fh
Timer TA1 (see Table 6-43)	0380h	000h to 03Fh
Timer TA2 (see Table 6-44)	0400h	000h to 03Fh
Timer TA3 (see Table 6-45)	0440h	000h to 03Fh
Backup Memory (see Table 6-46)	0480h	000h to 00Fh
32-Bit Hardware Multiplier (see Table 6-48)	04C0h	000h to 02Fh
DMA General Control (see Table 6-49)	0500h	000h to 00Fh
DMA Channel 0 (see Table 6-50)	0500h	010h to 01Fh
DMA Channel 1 (see Table 6-51)	0500h	020h to 02Fh

Table 6-21. Peripherals (continued)

MODULE NAME	BASE ADDRESS	OFFSET ADDRESS RANGE
DMA Channel 2 (see Table 6-52)	0500h	030h to 03Fh
RTC_C (see Table 6-47)	0C80h	000h to 03Fh
eUSCI_A0 (see Table 6-53)	05C0h	000h to 01Fh
eUSCI_A1 (see Table 6-54)	05E0h	000h to 01Fh
eUSCI_A2 (see Table 6-55)	0600h	000h to 01Fh
eUSCI_A3 (see Table 6-56)	0620h	000h to 01Fh
eUSCI_B0 (see Table 6-57)	0640h	000h to 02Fh
eUSCI_B1 (see Table 6-58)	0680h	000h to 02Fh
ADC10_A (see Table 6-59)	0740h	000h to 01Fh
SD24_B (see Table 6-60)	0800h	000h to 06Fh
Comparator_B (see Table 6-61)	08C0h	000h to 00Fh
AES Accelerator (see Table 6-62)	09C0h	000h to 00Fh
Auxiliary Supply (see Table 6-63)	09E0h	000h to 01Fh
LCD_C (see Table 6-64)	0A00h	000h to 05Fh

Table 6-22. Special Function Registers (Base Address: 0100h)

REGISTER DESCRIPTION	REGISTER	OFFSET
SFR interrupt enable	SFRIE1	00h
SFR interrupt flag	SFRIFG1	02h
SFR reset pin control	SFRRPCR	04h

Table 6-23. PMM Registers (Base Address: 0120h)

REGISTER DESCRIPTION	REGISTER	OFFSET
PMM control 0	PMMCTL0	00h
PMM control 1	PMMCTL1	02h
SVS high-side control	SVSMHCTL	04h
SVS low-side control	SVSMLCTL	06h
PMM interrupt flags	PMMIFG	0Ch
PMM interrupt enable	PMMIE	0Eh
PMM power mode 5 control 0	PM5CTL0	10h

Table 6-24. Flash Control Registers (Base Address: 0140h)

REGISTER DESCRIPTION	REGISTER	OFFSET
Flash control 1	FCTL1	00h
Flash control 3	FCTL3	04h
Flash control 4	FCTL4	06h

Table 6-25. CRC16 Registers (Base Address: 0150h)

REGISTER DESCRIPTION	REGISTER	OFFSET
CRC data input	CRC16DI	00h
CRC result	CRCINIRES	04h

Table 6-26. RAM Control Registers (Base Address: 0158h)

REGISTER DESCRIPTION	REGISTER	OFFSET
RAM control 0	RCCTL0	00h

Table 6-27. Watchdog Registers (Base Address: 015Ch)

REGISTER DESCRIPTION	REGISTER	OFFSET
Watchdog timer control	WDTCTL	00h

Table 6-28. UCS Registers (Base Address: 0160h)

REGISTER DESCRIPTION	REGISTER	OFFSET
UCS control 0	UCSCTL0	00h
UCS control 1	UCSCTL1	02h
UCS control 2	UCSCTL2	04h
UCS control 3	UCSCTL3	06h
UCS control 4	UCSCTL4	08h
UCS control 5	UCSCTL5	0Ah
UCS control 6	UCSCTL6	0Ch
UCS control 7	UCSCTL7	0Eh
UCS control 8	UCSCTL8	10h

Table 6-29. SYS Registers (Base Address: 0180h)

REGISTER DESCRIPTION	REGISTER	OFFSET
System control	SYSCCTL	00h
Bootloader configuration area	SYSBSLC	02h
JTAG mailbox control	SYSJMBC	06h
JTAG mailbox input 0	SYSJMBI0	08h
JTAG mailbox input 1	SYSJMBI1	0Ah
JTAG mailbox output 0	SYSJMBO0	0Ch
JTAG mailbox output 1	SYSJMBO1	0Eh
Bus Error vector generator	SYSBERRIV	18h
User NMI vector generator	SYSUNIV	1Ah
System NMI vector generator	SYSSNIV	1Ch
Reset vector generator	SYSRSTIV	1Eh

Table 6-30. Shared Reference Registers (Base Address: 01B0h)

REGISTER DESCRIPTION	REGISTER	OFFSET
Shared reference control	REFCTL	00h

Table 6-31. Port Mapping Controller (Base Address: 01C0h)

REGISTER DESCRIPTION	REGISTER	OFFSET
Port mapping password	PMAPPWD	00h
Port mapping control	PMAPCTL	02h

Table 6-32. Port Mapping for Port P2 (Base Address: 01D0h)

REGISTER DESCRIPTION	REGISTER	OFFSET
Port P2.0 mapping	P2MAP0	00h
Port P2.1 mapping	P2MAP1	01h
Port P2.2 mapping	P2MAP2	02h
Port P2.3 mapping	P2MAP3	03h
Port P2.4 mapping	P2MAP4	04h
Port P2.5 mapping	P2MAP5	05h
Port P2.6 mapping	P2MAP6	06h
Port P2.7 mapping	P2MAP7	07h

Table 6-33. Port Mapping for Port P3 (Base Address: 01D8h)

REGISTER DESCRIPTION	REGISTER	OFFSET
Port P3.0 mapping	P3MAP0	00h
Port P3.1 mapping	P3MAP1	01h
Port P3.2 mapping	P3MAP2	02h
Port P3.3 mapping	P3MAP3	03h
Port P3.4 mapping	P3MAP4	04h
Port P3.5 mapping	P3MAP5	05h
Port P3.6 mapping	P3MAP6	06h
Port P3.7 mapping	P3MAP7	07h

Table 6-34. Port Mapping for Port P4 (Base Address: 01E0h)

REGISTER DESCRIPTION	REGISTER	OFFSET
Port P4.0 mapping	P4MAP0	00h
Port P4.1 mapping	P4MAP1	01h
Port P4.2 mapping	P4MAP2	02h
Port P4.3 mapping	P4MAP3	03h
Port P4.4 mapping	P4MAP4	04h
Port P4.5 mapping	P4MAP5	05h
Port P4.6 mapping	P4MAP6	06h
Port P4.7 mapping	P4MAP7	07h

Table 6-35. Port P1, P2 Registers (Base Address: 0200h)

REGISTER DESCRIPTION	REGISTER	OFFSET
Port P1 input	P1IN	00h
Port P1 output	P1OUT	02h
Port P1 direction	P1DIR	04h
Port P1 resistor enable	P1REN	06h
Port P1 drive strength	P1DS	08h
Port P1 selection 0	P1SEL0	0Ah
Port P1 selection 1	P1SEL1	0Ch
Port P1 interrupt vector word	P1IV	0Eh
Port P1 interrupt edge select	P1IES	18h
Port P1 interrupt enable	P1IE	1Ah
Port P1 interrupt flag	P1IFG	1Ch
Port P2 input	P2IN	01h
Port P2 output	P2OUT	03h
Port P2 direction	P2DIR	05h
Port P2 resistor enable	P2REN	07h
Port P2 drive strength	P2DS	09h
Port P2 selection 0	P2SEL0	0Bh
Port P2 selection 1 ⁽¹⁾	P2SEL1	0Dh
Port P2 interrupt vector word	P2IV	1Eh
Port P2 interrupt edge select	P2IES	19h
Port P2 interrupt enable	P2IE	1Bh
Port P2 interrupt flag	P2IFG	1Dh

(1) P2SEL1 is an empty control register to be consistent with P1SEL1 in 16-bit access.

Table 6-36. Port P3, P4 Registers (Base Address: 0220h)

REGISTER DESCRIPTION	REGISTER	OFFSET
Port P3 input	P3IN	00h
Port P3 output	P3OUT	02h
Port P3 direction	P3DIR	04h
Port P3 resistor enable	P3REN	06h
Port P3 drive strength	P3DS	08h
Port P3 selection 0	P3SEL0	0Ah
Port P4 input	P4IN	01h
Port P4 output	P4OUT	03h
Port P4 direction	P4DIR	05h
Port P4 resistor enable	P4REN	07h
Port P4 drive strength	P4DS	09h
Port P4 selection 0	P4SEL0	0Bh

Table 6-37. Port P5, P6 Registers (Base Address: 0240h)

REGISTER DESCRIPTION	REGISTER	OFFSET
Port P5 input	P5IN	00h
Port P5 output	P5OUT	02h
Port P5 direction	P5DIR	04h
Port P5 resistor enable	P5REN	06h
Port P5 drive strength	P5DS	08h
Port P5 selection 0	P5SEL0	0Ah
Port P5 selection 1	P5SEL1	0Ch
Port P6 input	P6IN	01h
Port P6 output	P6OUT	03h
Port P6 direction	P6DIR	05h
Port P6 resistor enable	P6REN	07h
Port P6 drive strength	P6DS	09h
Port P6 selection 0	P6SEL0	0Bh
Port P6 selection 1 ⁽¹⁾	P6SEL1	0Dh

(1) P6SEL1 is an empty control register to be consistent with P5SEL1 in 16-bit access.

Table 6-38. Port P7, P8 Registers (Base Address: 0260h)

REGISTER DESCRIPTION	REGISTER	OFFSET
Port P7 input	P7IN	00h
Port P7 output	P7OUT	02h
Port P7 direction	P7DIR	04h
Port P7 resistor enable	P7REN	06h
Port P7 drive strength	P7DS	08h
Port P7 selection 0	P7SEL0	0Ah
Port P8 input	P8IN	01h
Port P8 output	P8OUT	03h
Port P8 direction	P8DIR	05h
Port P8 resistor enable	P8REN	07h
Port P8 drive strength	P8DS	09h
Port P8 selection 0	P8SEL0	0Bh

Table 6-39. Port P9, P10 Registers (Base Address: 0280h)

REGISTER DESCRIPTION	REGISTER	OFFSET
Port P9 input	P9IN	00h
Port P9 output	P9OUT	02h
Port P9 direction	P9DIR	04h
Port P9 resistor enable	P9REN	06h
Port P9 drive strength	P9DS	08h
Port P9 selection 0	P9SELO	0Ah
Port P10 input	P10IN	01h
Port P10 output	P10OUT	03h
Port P10 direction	P10DIR	05h
Port P10 resistor enable	P10REN	07h
Port P10 drive strength	P10DS	09h
Port P10 selection 0	P10SELO	0Bh

Table 6-40. Port 11 Registers (Base Address: 02A0h)

REGISTER DESCRIPTION	REGISTER	OFFSET
Port P11 input	P11IN	00h
Port P11 output	P11OUT	02h
Port P11 direction	P11DIR	04h
Port P11 resistor enable	P11REN	06h
Port P11 drive strength	P11DS	08h
Port P11 selection 0	P11SELO	0Ah

Table 6-41. Port J Registers (Base Address: 0320h)

REGISTER DESCRIPTION	REGISTER	OFFSET
Port PJ input	PJIN	00h
Port PJ output	PJOUT	02h
Port PJ direction	PJDIR	04h
Port PJ resistor enable	PJREN	06h
Port PJ drive strength	PJDS	08h
Port PJ selection	PJSEL	0Ah

Table 6-42. TA0 Registers (Base Address: 0340h)

REGISTER DESCRIPTION	REGISTER	OFFSET
TA0 control	TAOCTL	00h
Capture/compare control 0	TAOCTL0	02h
Capture/compare control 1	TAOCTL1	04h
Capture/compare control 2	TAOCTL2	06h
TA0 counter	TAOR	10h
Capture/compare 0	TAOCCR0	12h
Capture/compare 1	TAOCCR1	14h
Capture/compare 2	TAOCCR2	16h
TA0 expansion 0	TAOEX0	20h
TA0 interrupt vector	TAOIV	2Eh

Table 6-43. TA1 Registers (Base Address: 0380h)

REGISTER DESCRIPTION	REGISTER	OFFSET
TA1 control	TA1CTL	00h
Capture/compare control 0	TA1CCTL0	02h
Capture/compare control 1	TA1CCTL1	04h
TA1 counter	TA1R	10h
Capture/compare 0	TA1CCR0	12h
Capture/compare 1	TA1CCR1	14h
TA1 expansion 0	TA1EX0	20h
TA1 interrupt vector	TA1IV	2Eh

Table 6-44. TA2 Registers (Base Address: 0400h)

REGISTER DESCRIPTION	REGISTER	OFFSET
TA2 control	TA2CTL	00h
Capture/compare control 0	TA2CCTL0	02h
Capture/compare control 1	TA2CCTL1	04h
TA2 counter	TA2R	10h
Capture/compare 0	TA2CCR0	12h
Capture/compare 1	TA2CCR1	14h
TA2 expansion 0	TA2EX0	20h
TA2 interrupt vector	TA2IV	2Eh

Table 6-45. TA3 Registers (Base Address: 0440h)

REGISTER DESCRIPTION	REGISTER	OFFSET
TA3 control	TA3CTL	00h
Capture/compare control 0	TA3CCTL0	02h
Capture/compare control 1	TA3CCTL1	04h
TA3 counter	TA3R	10h
Capture/compare 0	TA3CCR0	12h
Capture/compare 1	TA3CCR1	14h
TA3 expansion 0	TA3EX0	20h
TA3 interrupt vector	TA3IV	2Eh

Table 6-46. Backup Memory Registers (Base Address: 0480h)

REGISTER DESCRIPTION	REGISTER	OFFSET
Backup memory 0	BAKMEM0	00h
Backup memory 1	BAKMEM1	02h
Backup memory 2	BAKMEM2	04h
Backup memory 3	BAKMEM3	06h

Table 6-47. RTC_C Registers (Base Address: 0C80h)

REGISTER DESCRIPTION	REGISTER	OFFSET
RTC control 0	RTCCTL0	00h
RTC password	RTCPWD	01h
RTC control 1	RTCCTL1	02h
RTC control 3	RTCCTL3	03h
RTC offset calibration	RTCOCAL	04h
RTC temperature compensation	RTCTCMP	06h
RTC prescaler 0 control	RTCP0CTL	08h
RTC prescaler 1 control	RTCP1CTL	0Ah
RTC prescaler 0	RTCP0	0Ch
RTC prescaler 1	RTCP1	0Dh
RTC interrupt vector word	RTCIV	0Eh
RTC seconds	RTCSEC	10h
RTC minutes	RTCMIN	11h
RTC hours	RTCHOUR	12h
RTC day of week	RTCDOW	13h
RTC days	RTCDAY	14h
RTC month	RTCMON	15h
RTC year	RTCYEAR	16h
RTC alarm minutes	RTCAMIN	18h
RTC alarm hours	RTCAHOUR	19h
RTC alarm day of week	RTCADOW	1Ah
RTC alarm days	RTCADAY	1Bh
Binary-to-BCD conversion	BIN2BCD	1Ch
BCD-to-binary conversion	BCD2BIN	1Eh
Real-time clock time capture control	RTCTCTL	20h
Tamper detect pin 0 control	RTCCAP0CTL	21h
Tamper detect pin 1 control	RTCCAP1CTL	22h
RTC seconds backup 0	RTCSECBAK0	30h
RTC minutes backup 0	RTCMINBAK0	31h
RTC hours backup 0	RTCHOURBAK0	32h
RTC days backup 0	RTCDAYBAK0	33h
RTC month backup 0	RTCMONBAK0	34h
RTC year backup 0	RTCYEARBAK0	36h
RTC seconds backup 1	RTCSECBAK1	38h
RTC minutes backup 1	RTCMINBAK1	39h
RTC hours backup 1	RTCHOURBAK1	3Ah
RTC days backup 1	RTCDAYBAK1	3Bh
RTC month backup 1	RTCMONBAK1	3Ch
RTC year backup 1	RTCYEARBAK1	3Eh

Table 6-48. 32-Bit Hardware Multiplier Registers (Base Address: 04C0h)

REGISTER DESCRIPTION	REGISTER	OFFSET
16-bit operand 1 – multiply	MPY	00h
16-bit operand 1 – signed multiply	MPYS	02h
16-bit operand 1 – multiply accumulate	MAC	04h
16-bit operand 1 – signed multiply accumulate	MACS	06h
16-bit operand 2	OP2	08h
16 × 16 result low word	RESLO	0Ah
16 × 16 result high word	RESHI	0Ch
16 × 16 sum extension	SUMEXT	0Eh
32-bit operand 1 – multiply low word	MPY32L	10h
32-bit operand 1 – multiply high word	MPY32H	12h
32-bit operand 1 – signed multiply low word	MPYS32L	14h
32-bit operand 1 – signed multiply high word	MPYS32H	16h
32-bit operand 1 – multiply accumulate low word	MAC32L	18h
32-bit operand 1 – multiply accumulate high word	MAC32H	1Ah
32-bit operand 1 – signed multiply accumulate low word	MACS32L	1Ch
32-bit operand 1 – signed multiply accumulate high word	MACS32H	1Eh
32-bit operand 2 – low word	OP2L	20h
32-bit operand 2 – high word	OP2H	22h
32 × 32 result 0 – least significant word	RES0	24h
32 × 32 result 1	RES1	26h
32 × 32 result 2	RES2	28h
32 × 32 result 3 – most significant word	RES3	2Ah
MPY32 control 0	MPY32CTL0	2Ch

Table 6-49. DMA General Control Registers (Base Address: 0500h)

REGISTER DESCRIPTION	REGISTER	OFFSET
DMA module control 0	DMACTL0	00h
DMA module control 1	DMACTL1	02h
DMA module control 2	DMACTL2	04h
DMA module control 3	DMACTL3	06h
DMA module control 4	DMACTL4	08h
DMA interrupt vector	DMAIV	0Eh

Table 6-50. DMA Channel 0 Registers (Base Address: 0500h)

REGISTER DESCRIPTION	REGISTER	OFFSET
DMA channel 0 control	DMA0CTL	10h
DMA channel 0 source address low	DMA0SAL	12h
DMA channel 0 source address high	DMA0SAH	14h
DMA channel 0 destination address low	DMA0DAL	16h
DMA channel 0 destination address high	DMA0DAH	18h
DMA channel 0 transfer size	DMA0SZ	1Ah

Table 6-51. DMA Channel 1 Registers (Base Address: 0500h)

REGISTER DESCRIPTION	REGISTER	OFFSET
DMA channel 1 control	DMA1CTL	20h
DMA channel 1 source address low	DMA1SAL	22h
DMA channel 1 source address high	DMA1SAH	24h
DMA channel 1 destination address low	DMA1DAL	26h
DMA channel 1 destination address high	DMA1DAH	28h
DMA channel 1 transfer size	DMA1SZ	2Ah

Table 6-52. DMA Channel 2 Registers (Base Address: 0500h)

REGISTER DESCRIPTION	REGISTER	OFFSET
DMA channel 2 control	DMA2CTL	30h
DMA channel 2 source address low	DMA2SAL	32h
DMA channel 2 source address high	DMA2SAH	34h
DMA channel 2 destination address low	DMA2DAL	36h
DMA channel 2 destination address high	DMA2DAH	38h
DMA channel 2 transfer size	DMA2SZ	3Ah

Table 6-53. eUSCI_A0 Registers (Base Address: 05C0h)

REGISTER DESCRIPTION	REGISTER	OFFSET
USCI_A control word 0	UCA0CTLW0	00h
USCI_A control word 1	UCA0CTLW1	02h
USCI_A baud rate 0	UCA0BR0	06h
USCI_A baud rate 1	UCA0BR1	07h
USCI_A modulation control	UCA0MCTLW	08h
USCI_A status	UCA0STAT	0Ah
USCI_A receive buffer	UCA0RXBUF	0Ch
USCI_A transmit buffer	UCA0TXBUF	0Eh
USCI_A LIN control	UCA0ABCTL	10h
USCI_A IrDA transmit control	UCA0IRTCTL	12h
USCI_A IrDA receive control	UCA0IRRCTL	13h
USCI_A interrupt enable	UCA0IE	1Ah
USCI_A interrupt flags	UCA0IFG	1Ch
USCI_A interrupt vector word	UCA0IV	1Eh

Table 6-54. eUSCI_A1 Registers (Base Address:05E0h)

REGISTER DESCRIPTION	REGISTER	OFFSET
USCI_A control word 0	UCA1CTLW0	00h
USCI_A control word 1	UCA1CTLW1	02h
USCI_A baud rate 0	UCA1BR0	06h
USCI_A baud rate 1	UCA1BR1	07h
USCI_A modulation control	UCA1MCTLW	08h
USCI_A status	UCA1STAT	0Ah
USCI_A receive buffer	UCA1RXBUF	0Ch
USCI_A transmit buffer	UCA1TXBUF	0Eh
USCI_A LIN control	UCA1ABCTL	10h
USCI_A IrDA transmit control	UCA1IRTCTL	12h
USCI_A IrDA receive control	UCA1IRRCTL	13h
USCI_A interrupt enable	UCA1IE	1Ah
USCI_A interrupt flags	UCA1IFG	1Ch
USCI_A interrupt vector word	UCA1IV	1Eh

Table 6-55. eUSCI_A2 Registers (Base Address:0600h)

REGISTER DESCRIPTION	REGISTER	OFFSET
USCI_A control word 0	UCA2CTLW0	00h
USCI_A control word 1	UCA2CTLW1	02h
USCI_A baud rate 0	UCA2BR0	06h
USCI_A baud rate 1	UCA2BR1	07h
USCI_A modulation control	UCA2MCTLW	08h
USCI_A status	UCA2STAT	0Ah
USCI_A receive buffer	UCA2RXBUF	0Ch
USCI_A transmit buffer	UCA2TXBUF	0Eh
USCI_A LIN control	UCA2ABCTL	10h
USCI_A IrDA transmit control	UCA2IRTCTL	12h
USCI_A IrDA receive control	UCA2IRRCTL	13h
USCI_A interrupt enable	UCA2IE	1Ah
USCI_A interrupt flags	UCA2IFG	1Ch
USCI_A interrupt vector word	UCA2IV	1Eh

Table 6-56. eUSCI_A3 Registers (Base Address: 0620h)

REGISTER DESCRIPTION	REGISTER	OFFSET
USCI_A control word 0	UCA3CTLW0	00h
USCI_A control word 1	UCA3CTLW1	02h
USCI_A baud rate 0	UCA3BR0	06h
USCI_A baud rate 1	UCA3BR1	07h
USCI_A modulation control	UCA3MCTLW	08h
USCI_A status	UCA3STAT	0Ah
USCI_A receive buffer	UCA3RXBUF	0Ch
USCI_A transmit buffer	UCA3TXBUF	0Eh
USCI_A LIN control	UCA3ABCTL	10h
USCI_A IrDA transmit control	UCA3IRTCTL	12h
USCI_A IrDA receive control	UCA3IRRCTL	13h
USCI_A interrupt enable	UCA3IE	1Ah
USCI_A interrupt flags	UCA3IFG	1Ch
USCI_A interrupt vector word	UCA3IV	1Eh

Table 6-57. eUSCI_B0 Registers (Base Address: 0640h)

REGISTER DESCRIPTION	REGISTER	OFFSET
USCI_B control word 0	UCB0CTLW0	00h
USCI_B control word 1	UCB0CTLW1	02h
USCI_B bit rate 0	UCB0BR0	06h
USCI_B bit rate 1	UCB0BR1	07h
USCI_B status word	UCB0STATW	08h
USCI_B byte counter threshold	UCB0TBCNT	0Ah
USCI_B receive buffer	UCB0RXBUF	0Ch
USCI_B transmit buffer	UCB0TXBUF	0Eh
USCI_B I2C own address 0	UCB0I2COA0	14h
USCI_B I2C own address 1	UCB0I2COA1	16h
USCI_B I2C own address 2	UCB0I2COA2	18h
USCI_B I2C own address 3	UCB0I2COA3	1Ah
USCI_B received address	UCB0ADDRX	1Ch
USCI_B address mask	UCB0ADDMASK	1Eh
USCI I2C slave address	UCB0I2CSA	20h
USCI interrupt enable	UCB0IE	2Ah
USCI interrupt flags	UCB0IFG	2Ch
USCI interrupt vector word	UCB0IV	2Eh

Table 6-58. eUSCI_B1 Registers (Base Address: 0680h)

REGISTER DESCRIPTION	REGISTER	OFFSET
USCI_B control word 0	UCB1CTLW0	00h
USCI_B control word 1	UCB1CTLW1	02h
USCI_B bit rate 0	UCB1BR0	06h
USCI_B bit rate 1	UCB1BR1	07h
USCI_B status word	UCB1STATW	08h
USCI_B byte counter threshold	UCB1TBCNT	0Ah
USCI_B receive buffer	UCB1RXBUF	0Ch
USCI_B transmit buffer	UCB1TXBUF	0Eh
USCI_B I2C own address 0	UCB1I2COA0	14h
USCI_B I2C own address 1	UCB1I2COA1	16h
USCI_B I2C own address 2	UCB1I2COA2	18h
USCI_B I2C own address 3	UCB1I2COA3	1Ah
USCI_B received address	UCB1ADDRX	1Ch
USCI_B address mask	UCB1ADDMASK	1Eh
USCI I2C slave address	UCB1I2CSA	20h
USCI interrupt enable	UCB1IE	2Ah
USCI interrupt flags	UCB1IFG	2Ch
USCI interrupt vector word	UCB1IV	2Eh

Table 6-59. ADC10_A Registers (Base Address: 0740h)

REGISTER DESCRIPTION	REGISTER	OFFSET
ADC10_A control 0	ADC10CTL0	00h
ADC10_A control 1	ADC10CTL1	02h
ADC10_A control 2	ADC10CTL2	04h
ADC10_A window comparator low threshold	ADC10LO	06h
ADC10_A window comparator high threshold	ADC10HI	08h
ADC10_A memory control 0	ADC10MCTL0	0Ah
ADC10_A conversion memory	ADC10MCTL0	12h
ADC10_A interrupt enable	ADC10IE	1Ah
ADC10_A interrupt flags	ADC10IGH	1Ch
ADC10_A interrupt vector word	ADC10IV	1Eh

Table 6-60. SD24_B Registers (Base Address: 0800h)

REGISTER DESCRIPTION	REGISTER	OFFSET
SD24_B control 0	SD24BCTL0	00h
SD24_B control 1	SD24BCTL1	02h
SD24_B trigger control	SD24BTRGCTL	04h
SD24_B trigger OSR control	SD24BTRGOSR	06h
SD24_B trigger preload	SD24BTRGPRE	08h
SD24_B interrupt flag	SD24BIFG	0Ah
SD24_B interrupt enable	SD24BIE	0Ch
SD24_B interrupt vector	SD24BIV	0Eh
SD24_B converter 0 control	SD24BCCTL0	10h
SD24_B converter 0 input control	SD24BINCTL0	12h
SD24_B converter 0 OSR control	SD24BOSR0	14h
SD24_B converter 0 preload	SD24BPRE0	16h
SD24_B converter 1 control	SD24BCCTL1	18h
SD24_B converter 1 input control	SD24BINCTL1	1Ah
SD24_B converter 1 OSR control	SD24BOSR1	1Ch
SD24_B converter 1 preload	SD24BPRE1	1Eh
SD24_B converter 2 control	SD24BCCTL2	20h
SD24_B converter 2 input control	SD24BINCTL2	22h
SD24_B converter 2 OSR control	SD24BOSR2	24h
SD24_B converter 2 preload	SD24BPRE2	26h
SD24_B converter 3 control	SD24BCCTL3	28h
SD24_B converter 3 input control	SD24BINCTL3	2Ah
SD24_B converter 3 OSR control	SD24BOSR3	2Ch
SD24_B converter 3 preload	SD24BPRE3	2Eh
SD24_B converter 4 control	SD24BCCTL4	30h
SD24_B converter 4 input control	SD24BINCTL4	32h
SD24_B converter 4 OSR control	SD24BOSR4	34h
SD24_B converter 4 preload	SD24BPRE4	36h
SD24_B converter 5 control	SD24BCCTL5	38h
SD24_B converter 5 Input control	SD24BINCTL5	3Ah
SD24_B converter 5 OSR control	SD24BOSR5	3Ch
SD24_B converter 5 preload	SD24BPRE5	3Eh
SD24_B converter 6 control	SD24BCCTL6	40h
SD24_B converter 6 Input control	SD24BINCTL6	42h
SD24_B converter 6 OSR control	SD24BOSR6	44h
SD24_B converter 6 preload	SD24BPRE6	46h
SD24_B converter 0 conversion memory low word	SD24BMEML0	50h
SD24_B converter 0 conversion memory high word	SD24BMEMH0	52h
SD24_B converter 1 conversion memory low word	SD24BMEML1	54h
SD24_B converter 1 conversion memory high word	SD24BMEMH1	56h
SD24_B converter 2 conversion memory low word	SD24BMEML2	58h
SD24_B converter 2 conversion memory high word	SD24BMEMH2	5Ah
SD24_B converter 3 conversion memory low word	SD24BMEML3	5Ch
SD24_B converter 3 conversion memory high word	SD24BMEMH3	5Eh
SD24_B converter 4 conversion memory low word	SD24BMEML4	60h
SD24_B converter 4 conversion memory high word	SD24BMEMH4	62h
SD24_B converter 5 conversion memory low word	SD24BMEML5	64h

Table 6-60. SD24_B Registers (Base Address: 0800h) (continued)

REGISTER DESCRIPTION	REGISTER	OFFSET
SD24_B converter 5 conversion memory high word	SD24BMEMH5	66h
SD24_B converter 6 conversion memory low word	SD24BMEML6	68h
SD24_B converter 6 conversion memory high word	SD24BMEMH6	6Ah

Table 6-61. Comparator_B Register (Base Address: 08C0h)

REGISTER DESCRIPTION	REGISTER	OFFSET
Comp_B control 0	CBCTL0	00h
Comp_B control 1	CBCTL1	02h
Comp_B control 2	CBCTL2	04h
Comp_B control 3	CBCTL3	06h
Comp_B interrupt	CBINT	0Ch
Comp_B interrupt vector word	CBIV	0Eh

Table 6-62. AES Accelerator Registers (Base Address: 09C0h)

REGISTER DESCRIPTION	REGISTER	OFFSET
AES accelerator control 0	AESACTL0	00h
AES accelerator status	AESASTAT	04h
AES accelerator key	AESAKEY	06h
AES accelerator data in	AESADIN	08h
AES accelerator data out	AESADOUT	0Ah

Table 6-63. Auxiliary Supply Registers (Base Address: 09E0h)

REGISTER DESCRIPTION	REGISTER	OFFSET
Auxiliary supply control 0	AUXCTL0	00h
Auxiliary supply control 1	AUXCTL1	02h
Auxiliary supply control 2	AUXCTL2	04h
AUX2 charger control	AUX2CHCTL	12h
AUX3 charger control	AUX3CHCTL	14h
AUX ADC control	AUXADCCTL	16h
AUX interrupt flag	AUXIFG	1Ah
AUX interrupt enable	AUXIE	1Ch
AUX interrupt vector word	AUXIV	1Eh

Table 6-64. LCD_C Registers (Base Address: 0A00h)

REGISTER DESCRIPTION	REGISTER	OFFSET
LCD_C control 0	LCDCCTL0	000h
LCD_C control 1	LCDCCTL1	002h
LCD_C blinking control	LCDCBLKCTL	004h
LCD_C memory control	LCDCMEMCTL	006h
LCD_C voltage control	LCDCVCTL	008h
LCD_C port control 0	LCDCPCTL0	00Ah
LCD_C port control 1	LCDCPCTL1	00Ch
LCD_C port control 2	LCDCPCTL2	00Eh
LCD_C charge pump control	LCDCCPCTL	012h
LCD_C interrupt vector	LCDCIV	01Eh
Static and 2- to 4-mux modes		
LCD_C memory 1	LCDM1	020h
LCD_C memory 2	LCDM2	021h
⋮	⋮	⋮
LCD_C memory 20	LCDM20	033h
LCD_C blinking memory 1	LCDBM1	040h
LCD_C blinking memory 2	LCDBM2	041h
⋮	⋮	⋮
LCD_C blinking memory 20	LCDBM20	053h
5- to 8-mux modes		
LCD_C memory 1	LCDM1	020h
LCD_C memory 2	LCDM2	021h
⋮	⋮	⋮
LCD_C memory 40	LCDM40	047h

6.12 Input/Output Diagrams

6.12.1 Port P1 (P1.0 to P1.3) Input/Output With Schmitt Trigger (PEU Package Only)

Figure 6-6 shows the port diagram. Table 6-65 summarizes the selection of the pin functions.

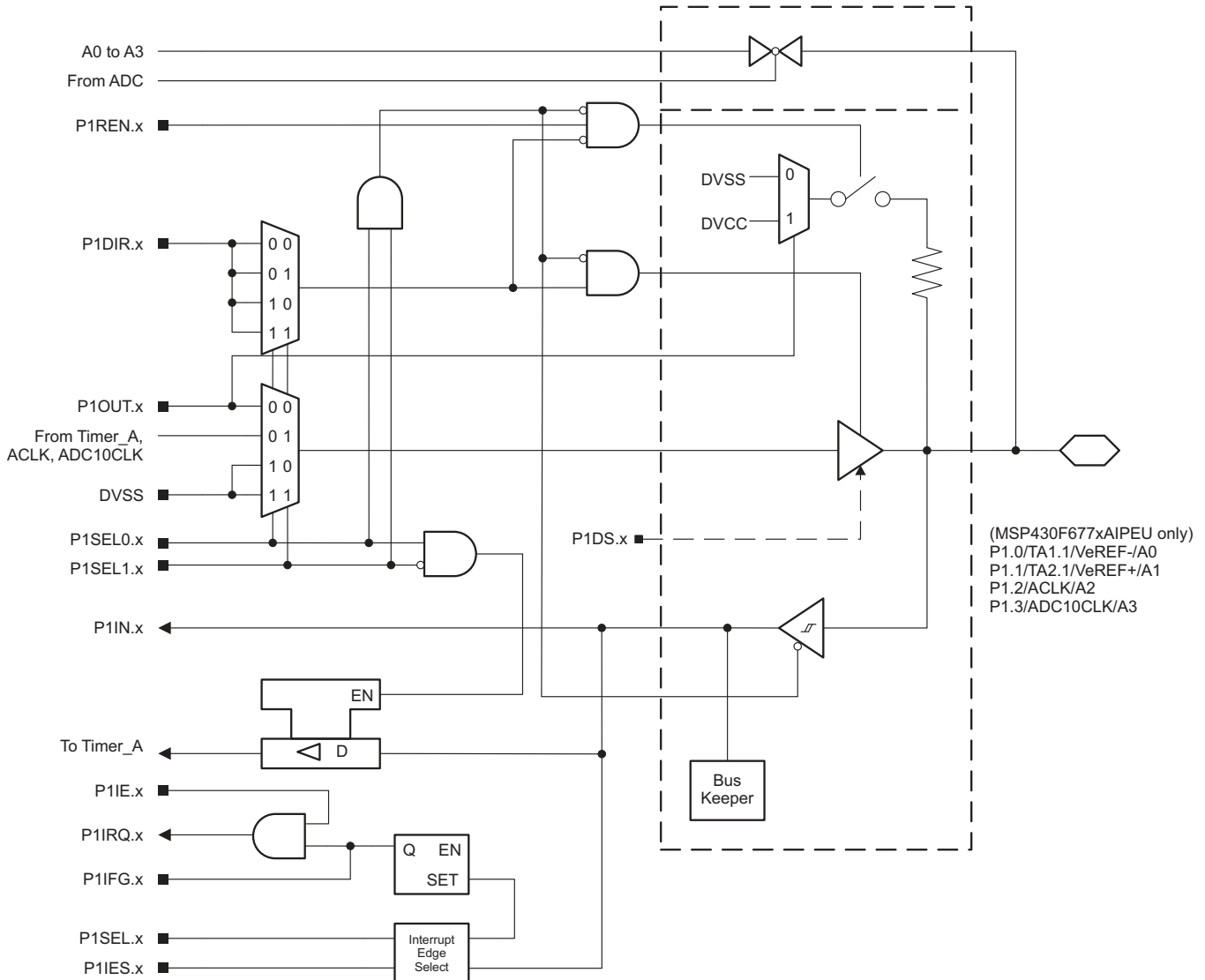

Figure 6-6. Port P1 (P1.0 to P1.3) Diagram (PEU Package Only)

Table 6-65. Port P1 (P1.0 to P1.3) Pin Functions (PEU Package Only)

PIN NAME (P1.x)	x	FUNCTION	CONTROL BITS OR SIGNALS ⁽¹⁾		
			P1DIR.x	P1SEL1.x	P1SEL0.x
P1.0/TA1.1/VeREF-/A0	0	P1.0 (I/O)	I:0; O:1	0	0
		TA1.CCI1A	0	0	1
		TA1.1	1	0	1
		N/A	0	1	0
		DVSS	1	1	0
		VeREF-/A0	X	1	1
P1.1/TA2.1/VeREF+/A1	1	P1.1 (I/O)	I:0; O:1	0	0
		TA2.CCI1A	0	0	1
		TA2.1	1	0	1
		N/A	0	1	0
		DVSS	1	1	0
		VeREF+/A1	X	1	1
P1.2/ACLK/A2	2	P1.2 (I/O)	I:0; O:1	0	0
		ACLK	1	0	1
		N/A	0	1	0
		DVSS	1	1	0
		A2	X	1	1
P1.3/ADC10CLK/A3	3	P1.3 (I/O)	I:0; O:1	0	0
		ADC10CLK	1	0	1
		N/A	0	1	0
		DVSS	1	1	0
		A3	X	1	1

(1) X = don't care

6.12.2 Port P1 (P1.0 to P1.3) Input/Output With Schmitt Trigger (PZ Package Only)

Figure 6-7 shows the port diagram. Table 6-66 summarizes the selection of the pin functions.

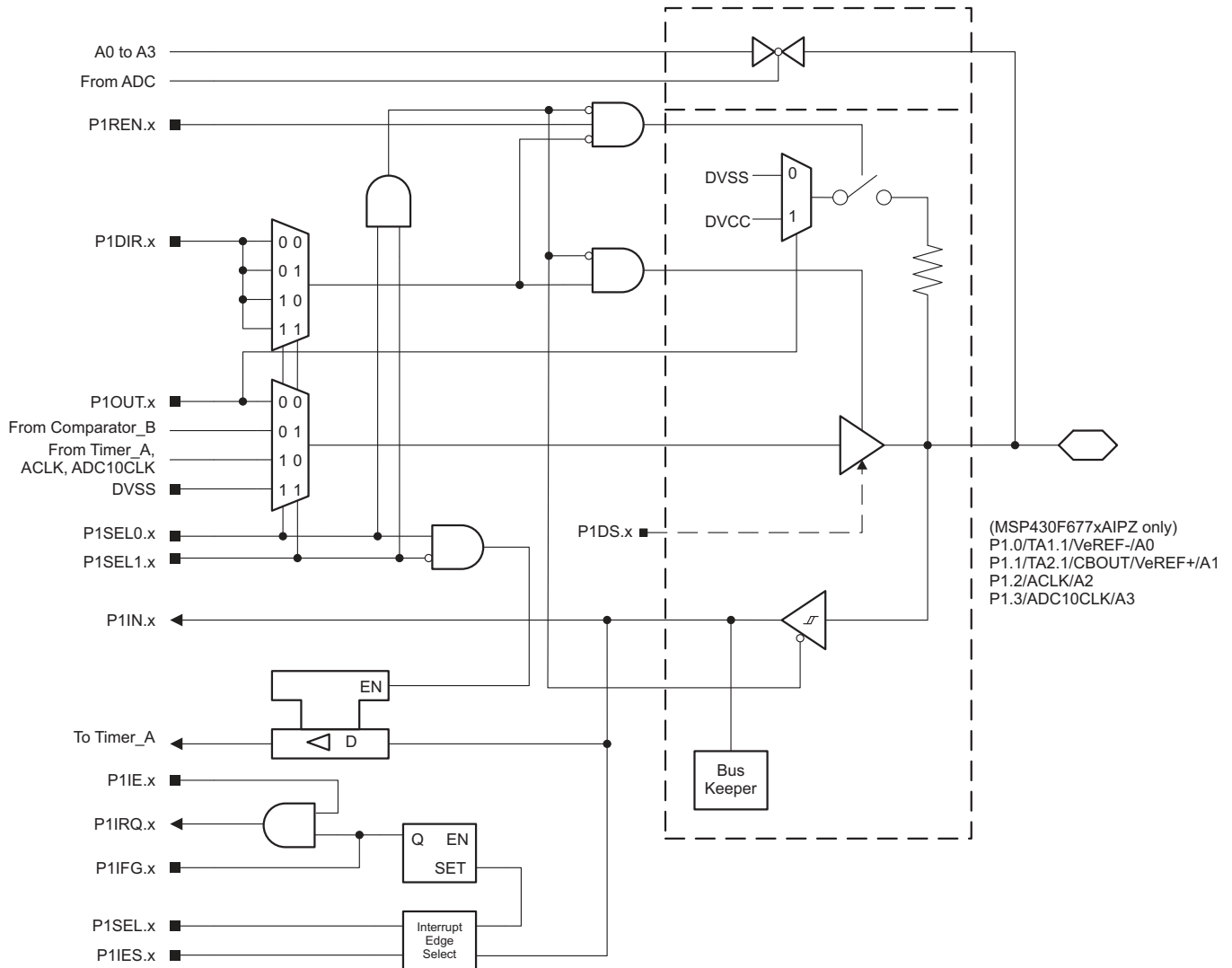

Figure 6-7. Port P1 (P1.0 to P1.3) Diagram (PZ Package Only)

Table 6-66. Port P1 (P1.0 to P1.3) Pin Functions (PZ Package Only)

PIN NAME (P1.x)	x	FUNCTION	CONTROL BITS OR SIGNALS ⁽¹⁾		
			P1DIR.x	P1SEL1.x	P1SEL0.x
P1.0/TA1.1/VeREF-/A0	0	P1.0 (I/O)	I:0; O:1	0	0
		TA1.CCI1A	0	0	1
		TA1.1	1	0	1
		N/A	0	1	0
		DVSS	1	1	0
		VeREF-/A0	X	1	1
P1.1/TA2.1/CBOUT/VeREF+/A1	1	P1.1 (I/O)	I:0; O:1	0	0
		TA2.CCI1A	0	0	1
		TA2.1	1	0	1
		N/A	0	1	0
		CBOUT	1	1	0
		VeREF+/A1	X	1	1
P1.2/ACLK/A2	2	P1.2 (I/O)	I:0; O:1	0	0
		ACLK	1	0	1
		N/A	0	1	0
		DVSS	1	1	0
		A2	X	1	1
P1.3/ADC10CLK/A3	3	P1.3 (I/O)	I:0; O:1	0	0
		ADC10CLK	1	0	1
		N/A	0	1	0
		DVSS	1	1	0
		A3	X	1	1

(1) X = don't care

6.12.3 Port P1 (P1.4 and P1.5) Input/Output With Schmitt Trigger

Figure 6-8 shows the port diagram. Table 6-67 summarizes the selection of the pin functions.

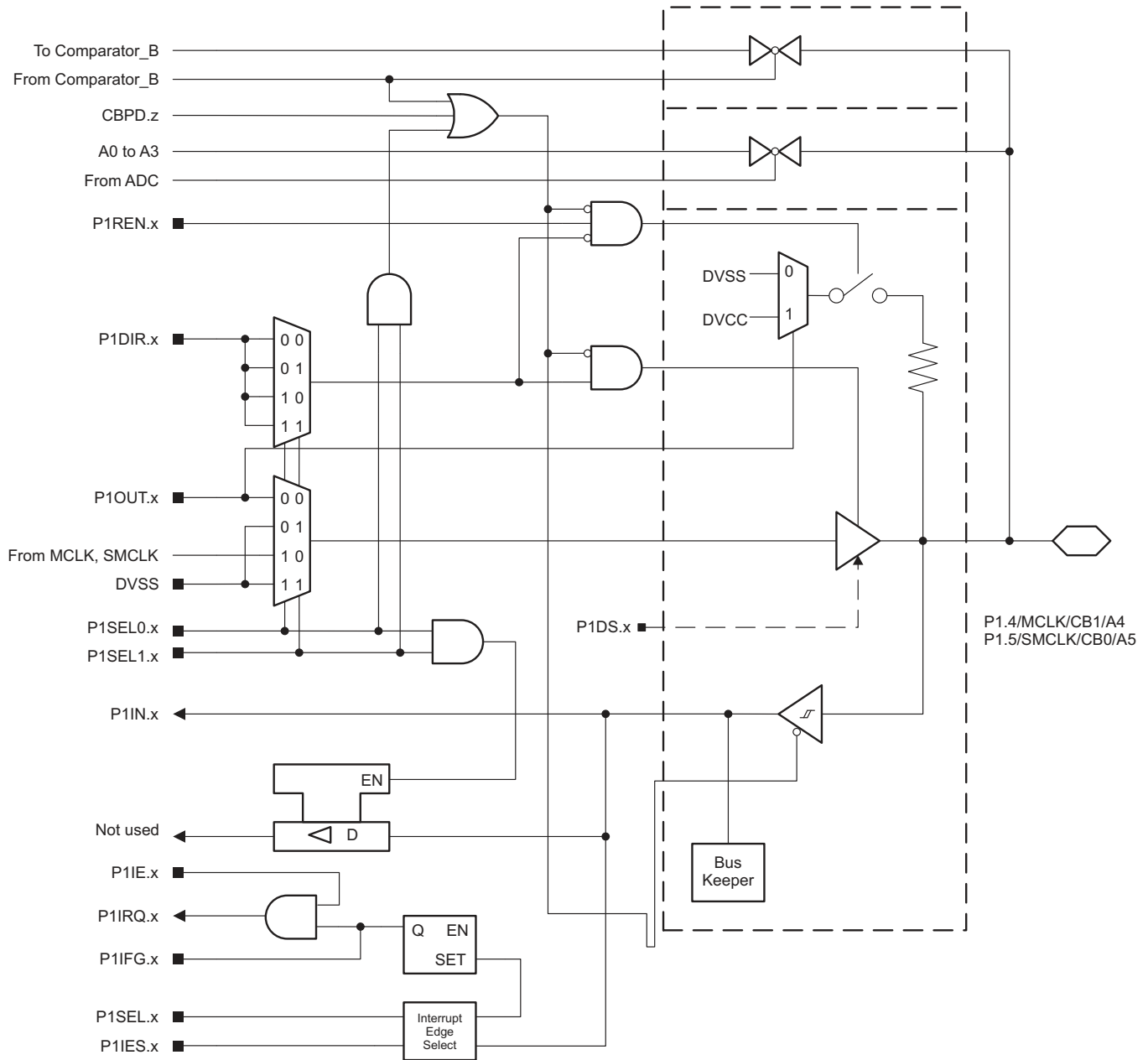

Figure 6-8. Port P1 (P1.4 and P1.5) Diagram

Table 6-67. Port P1 (P1.4 and P1.5) Pin Functions

PIN NAME (P1.x)	x	FUNCTION	CONTROL BITS OR SIGNALS ⁽¹⁾			
			P1DIR.x	P1SEL1.x	P1SEL0.x	CPBD.z
P1.4/MCLK/CB1/A4	4	P1.4 (I/O)	I:0; O:1	0	0	0
		MCLK	1	0	1	0
		N/A	0	1	0	0
		DVSS	1	1	0	0
		A4	X	1	1	0
		CB1	X	X	X	1 (z = 1)
P1.5/SMCLK/CB0/A5	5	P1.5 (I/O)	I:0; O:1	0	0	0
		SMCLK	1	0	1	0
		N/A	0	1	0	0
		DVSS	1	1	0	0
		A5	X	1	1	0
		CB0	X	X	X	1 (z = 0)

(1) X = don't care

6.12.4 Port P1 (P1.6 and P1.7) Input/Output With Schmitt Trigger

Figure 6-9 shows the port diagram. Table 6-68 summarizes the selection of the pin functions.

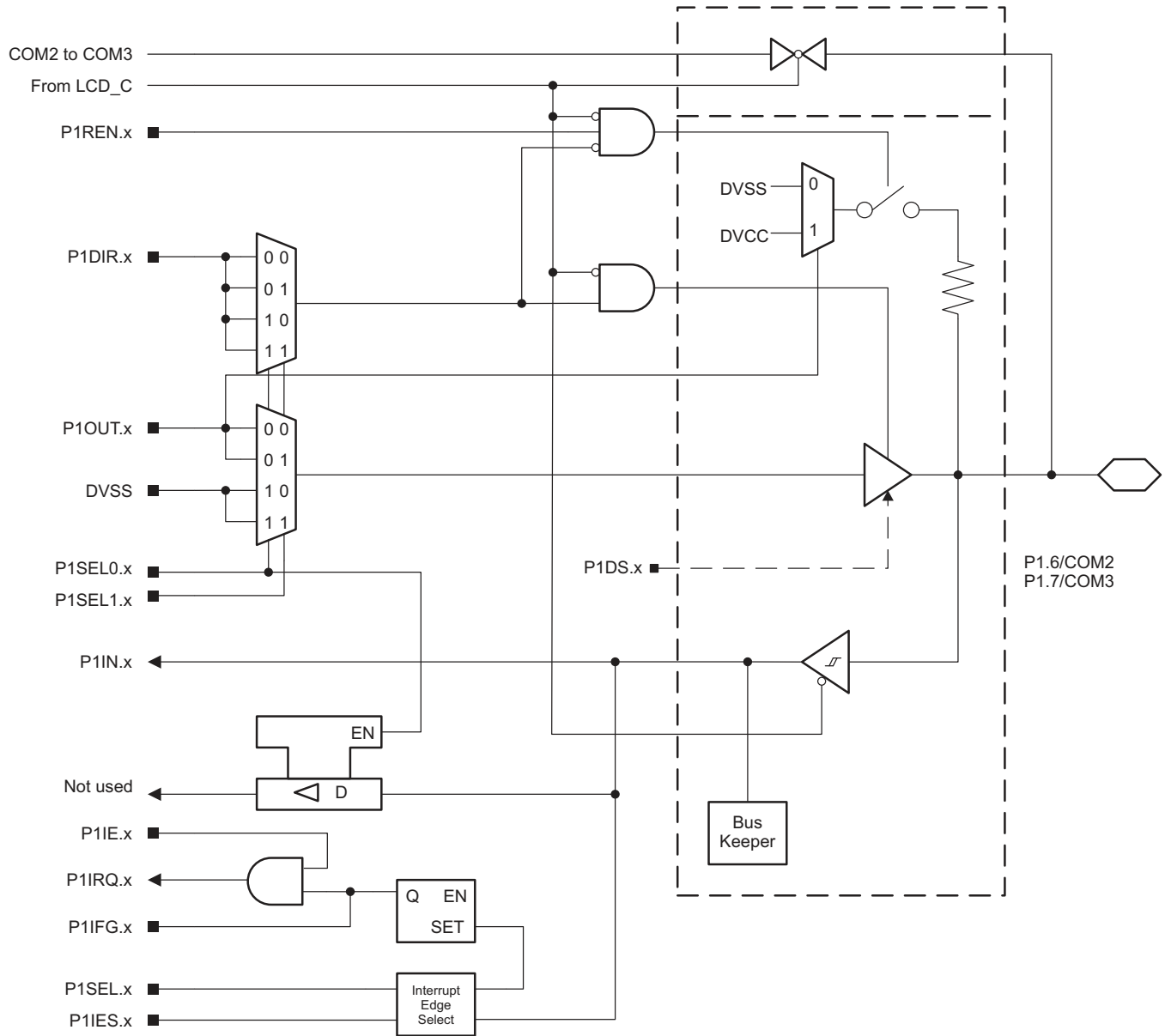

Figure 6-9. Port P1 (P1.6 and P1.7) Diagram

Table 6-68. Port P1 (P1.6 and P1.7) Pin Functions

PIN NAME (P1.x)	x	FUNCTION	CONTROL BITS OR SIGNALS ⁽¹⁾			
			P1DIR.x	P1SEL1.x	P1SEL0.x	COM Enable
P1.6/COM2	6	P1.6 (I/O)	I:0; O:1	X	0	0
		N/A	0	X	1	0
		DVSS	1	X	1	0
		COM2	X	X	X	1
P1.7/COM3	7	P1.7 (I/O)	I:0; O:1	X	0	0
		N/A	0	X	1	0
		DVSS	1	X	1	0
		COM3	X	X	X	1

(1) X = don't care

6.12.5 Port P2 (P2.0 to P2.7) Input/Output With Schmitt Trigger (PEU Package Only)

Figure 6-10 shows the port diagram. Table 6-69 summarizes the selection of the pin functions.

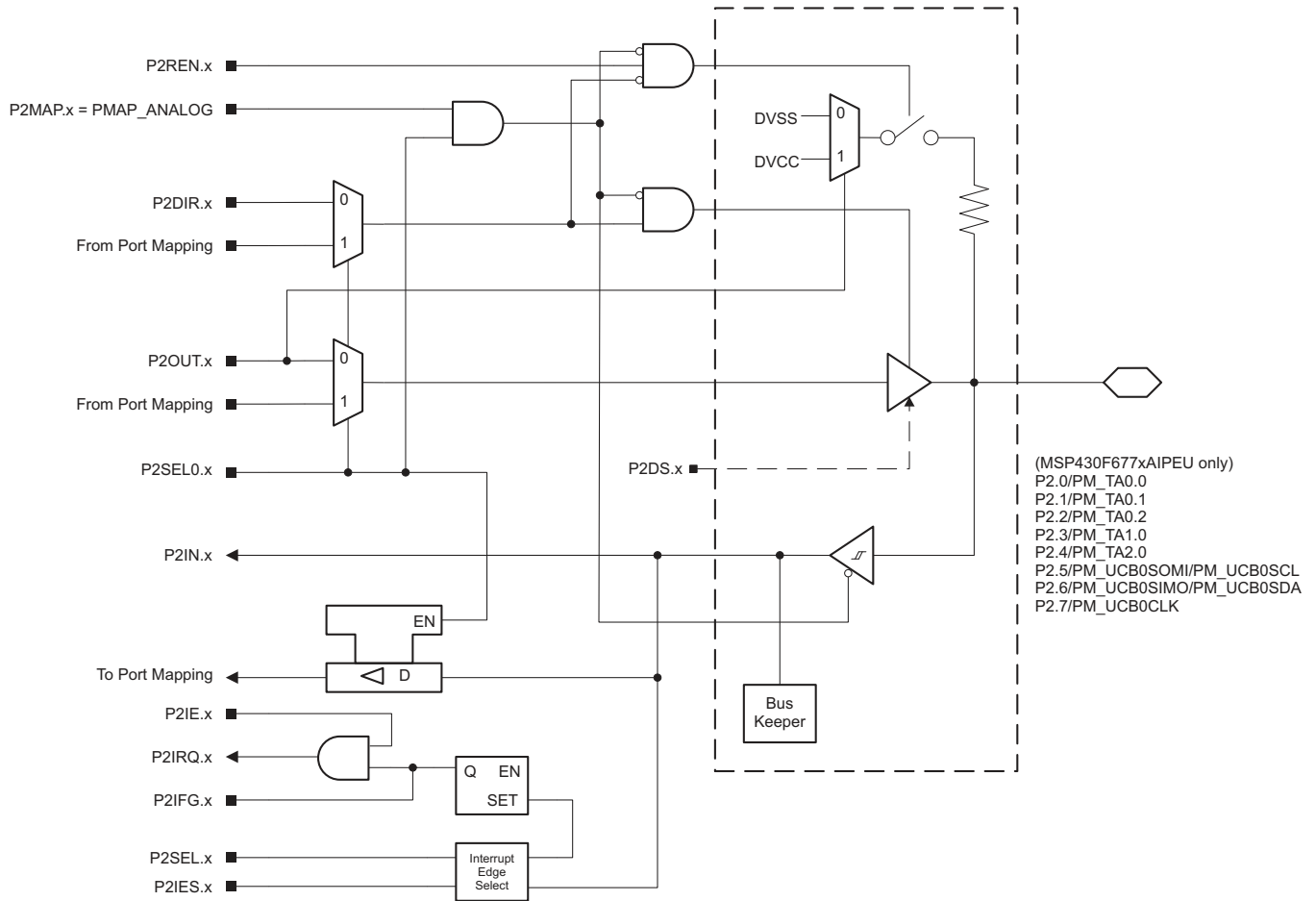

Figure 6-10. Port P2 (P2.0 to P2.7) Diagram (PEU Package Only)

Table 6-69. Port P2 (P2.0 to P2.7) Pin Functions (PEU Package Only)

PIN NAME (P2.x)	x	FUNCTION	CONTROL BITS OR SIGNALS ⁽¹⁾		
			P2DIR.x	P2SEL0.x	P2MAP.x
P2.0/PM_TA0.0	0	P2.0 (I/O)	I:0; O:1	0	X
		Mapped secondary digital function	X	1	≤ 30
		Output driver and input Schmitt trigger disabled	X	1	= 31
P2.1/PM_TA0.1	1	P2.1 (I/O)	I:0; O:1	0	X
		Mapped secondary digital function	X	1	≤ 30
		Output driver and input Schmitt trigger disabled	X	1	= 31
P2.2/PM_TA0.2	2	P2.2 (I/O)	I:0; O:1	0	X
		Mapped secondary digital function	X	1	≤ 30
		Output driver and input Schmitt trigger disabled	X	1	= 31
P2.3/PM_TA1.0	3	P2.3 (I/O)	I:0; O:1	0	X
		Mapped secondary digital function	X	1	≤ 30
		Output driver and input Schmitt trigger disabled	X	1	= 31
P2.4/PM_TA2.0	4	P2.4 (I/O)	I:0; O:1	0	X
		Mapped secondary digital function	X	1	≤ 30
		Output driver and input Schmitt trigger disabled	X	1	= 31
P2.5/PM_UCB0SOM/ PM_UCB0SCL	5	P2.5 (I/O)	I:0; O:1	0	X
		Mapped secondary digital function	X	1	≤ 30
		Output driver and input Schmitt trigger disabled	X	1	= 31
P2.6/PM_UCB0SIMO/ PM_UCB0SDA	6	P2.6 (I/O)	I:0; O:1	0	X
		Mapped secondary digital function	X	1	≤ 30
		Output driver and input Schmitt trigger disabled	X	1	= 31
P2.7/PM_UCB0CLK	7	P2.7 (I/O)	I:0; O:1	0	X
		Mapped secondary digital function	X	1	≤ 30
		Output driver and input Schmitt trigger disabled	X	1	= 31

(1) X = don't care

6.12.6 Port P2 (P2.0 to P2.3) Input/Output With Schmitt Trigger (PZ Package Only)

Figure 6-11 shows the port diagram. Table 6-70 summarizes the selection of the pin functions.

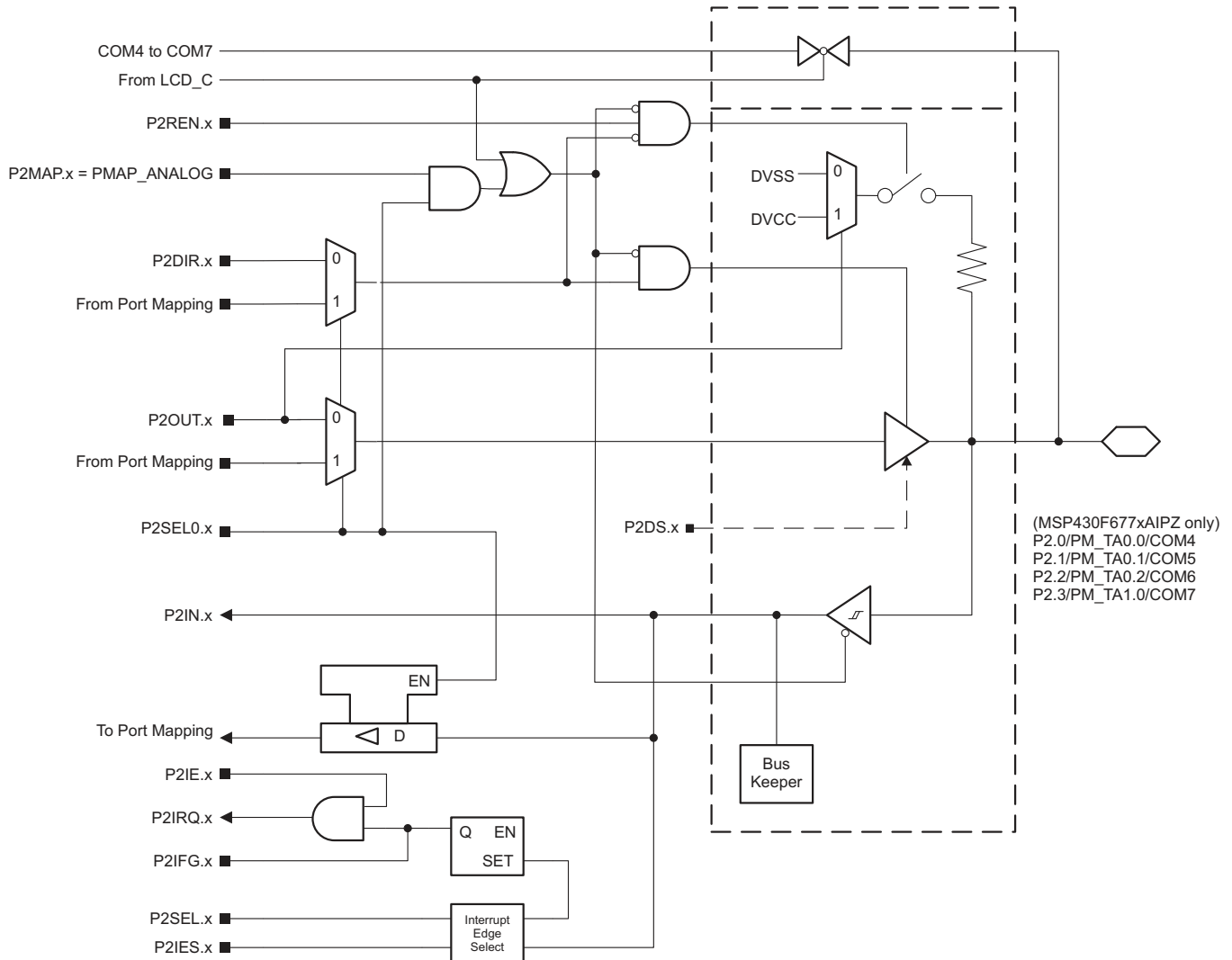

Figure 6-11. Port P2 (P2.0 to P2.3) Diagram (PZ Package Only)

Table 6-70. Port P2 (P2.0 to P2.3) Pin Functions (PZ Package Only)

PIN NAME (P2.x)	x	FUNCTION	CONTROL BITS OR SIGNALS ⁽¹⁾			
			P2DIR.x	P2SEL0.x	P2MAP.x	COM Enable
P2.0/PM_TA0.0/ COM4	0	P2.0 (I/O)	I:0; O:1	0	X	0
		Mapped secondary digital function	X	1	≤ 30	0
		Output driver and input Schmitt trigger disabled	X	1	= 31	0
		COM4	X	X	X	1
P2.1/PM_TA0.1/ COM5	1	P2.1 (I/O)	I:0; O:1	0	X	0
		Mapped secondary digital function	X	1	≤ 30	0
		Output driver and input Schmitt trigger disabled	X	1	= 31	0
		COM5	X	X	X	1
P2.2/PM_TA0.2/ COM6	2	P2.2 (I/O)	I:0; O:1	0	X	0
		Mapped secondary digital function	X	1	≤ 30	0
		Output driver and input Schmitt trigger disabled	X	1	= 31	0
		COM6	X	X	X	1
P2.3/PM_TA1.0/ COM7	3	P2.3 (I/O)	I:0; O:1	0	X	0
		Mapped secondary digital function	X	1	≤ 30	0
		Output driver and input Schmitt trigger disabled	X	1	= 31	0
		COM7	X	X	X	1

(1) X = don't care

6.12.7 Port P2 (P2.4 to P2.6) Input/Output With Schmitt Trigger (PZ Package Only)

Figure 6-12 shows the port diagram. Table 6-71 summarizes the selection of the pin functions.

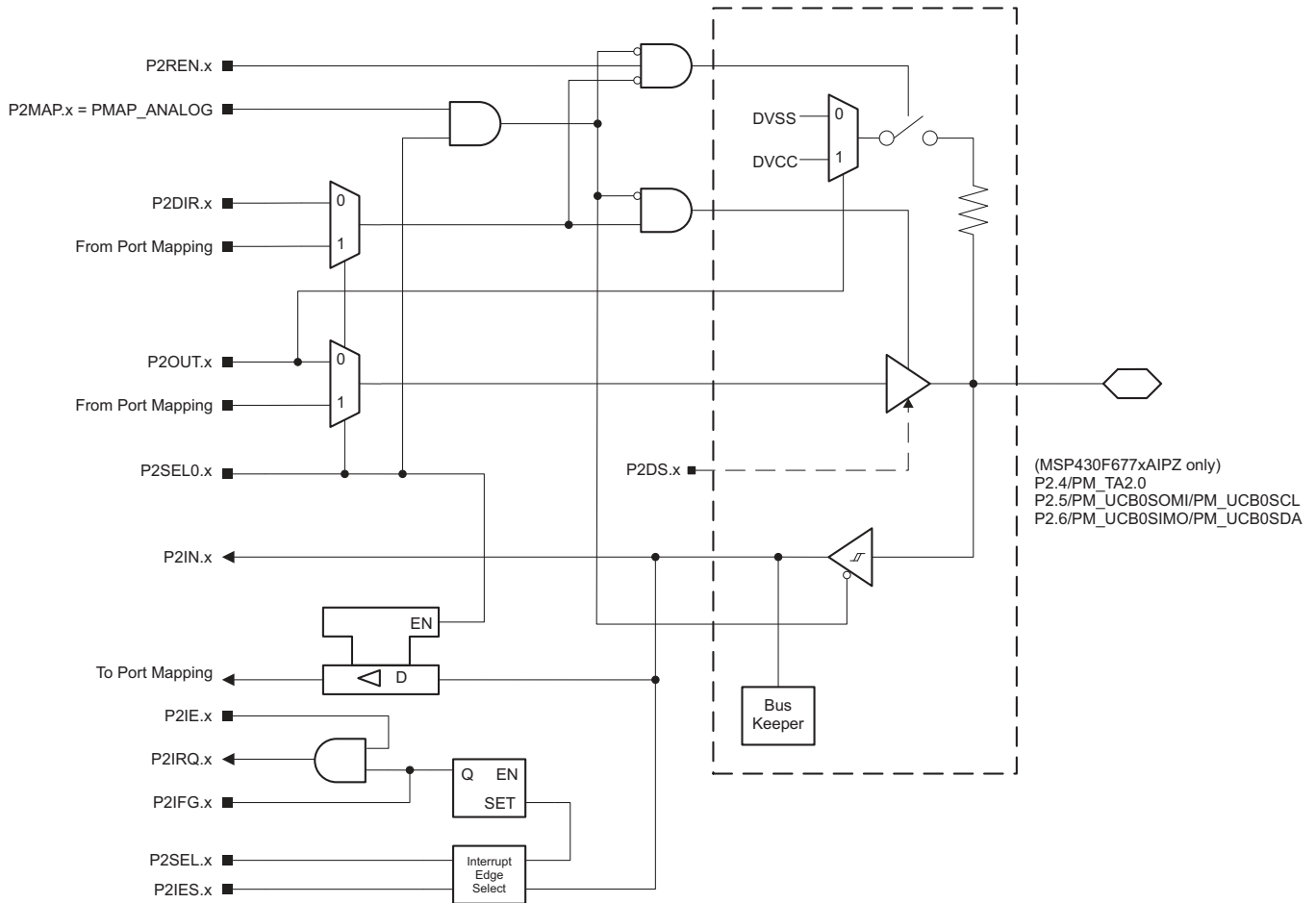

Figure 6-12. Port P2 (P2.4 to P2.6) Diagram (PZ Package Only)

Table 6-71. Port P2 (P2.4 to P2.6) Pin Functions (PZ Package Only)

PIN NAME (P2.x)	x	FUNCTION	CONTROL BITS OR SIGNALS ⁽¹⁾		
			P2DIR.x	P2SEL0.x	P2MAP.x
P2.4/PM_TA2.0/R23	4	P2.4 (I/O)	I:0; O:1	0	X
		Mapped secondary digital function	X	1	≤ 30
		R23	X	1	= 31
P2.5/PM_UCB0SOMI/PM_UCB0SCL/R13	5	P2.5 (I/O)	I:0; O:1	0	X
		Mapped secondary digital function	X	1	≤ 30
		R13	X	1	= 31
P2.6/PM_UCB0SIMO/PM_UCB0SDA/R03	6	P2.6 (I/O)	I:0; O:1	0	X
		Mapped secondary digital function	X	1	≤ 30
		R03	X	1	= 31

(1) X = don't care

6.12.8 Port P2 (P2.7) Input/Output With Schmitt Trigger (PZ Package Only)

Figure 6-13 shows the port diagram. Table 6-72 summarizes the selection of the pin functions.

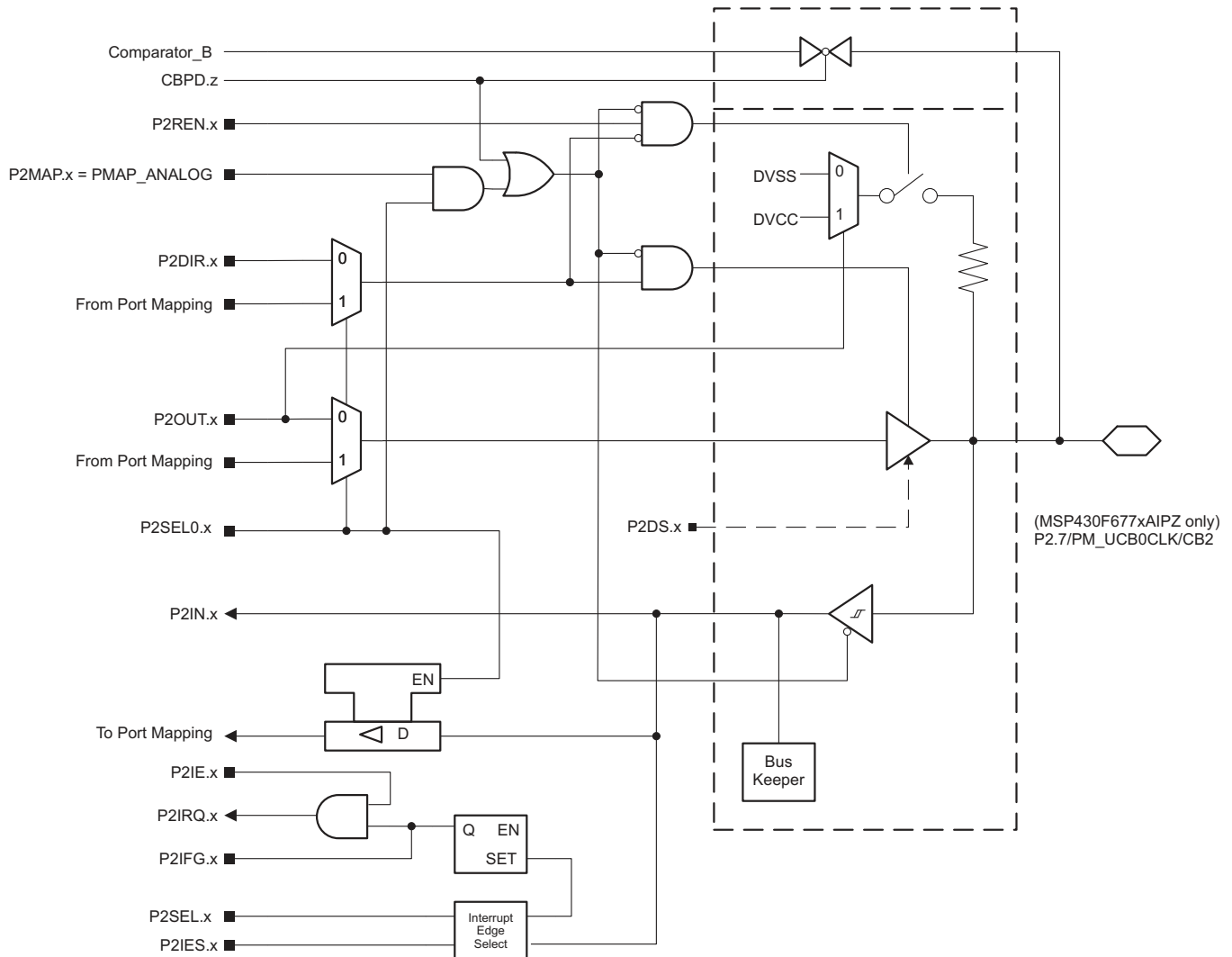

Figure 6-13. Port P2 (P2.7) Diagram (PZ Package Only)

Table 6-72. Port P2 (P2.7) Pin Functions (PZ Package Only)

PIN NAME (P2.x)	x	FUNCTION	CONTROL BITS OR SIGNALS ⁽¹⁾			
			P2DIR.x	P2SEL0.x	P2MAP.x	CBPD.z
P2.7/PM_UCB0CLK/ CB2	7	P2.7 (I/O)	I:0; O:1	0	X	0
		Mapped secondary digital function	X	1	≤ 30	0
		Output driver and input Schmitt trigger disabled	X	1	= 31	0
		CB2	X	X	X	1 (z = 2)

(1) X = don't care

6.12.9 Ports P3 (P3.0 to P3.7) Input/Output With Schmitt Trigger (PEU Package Only)

Figure 6-14 shows the port diagram. Table 6-73 summarizes the selection of the pin functions.

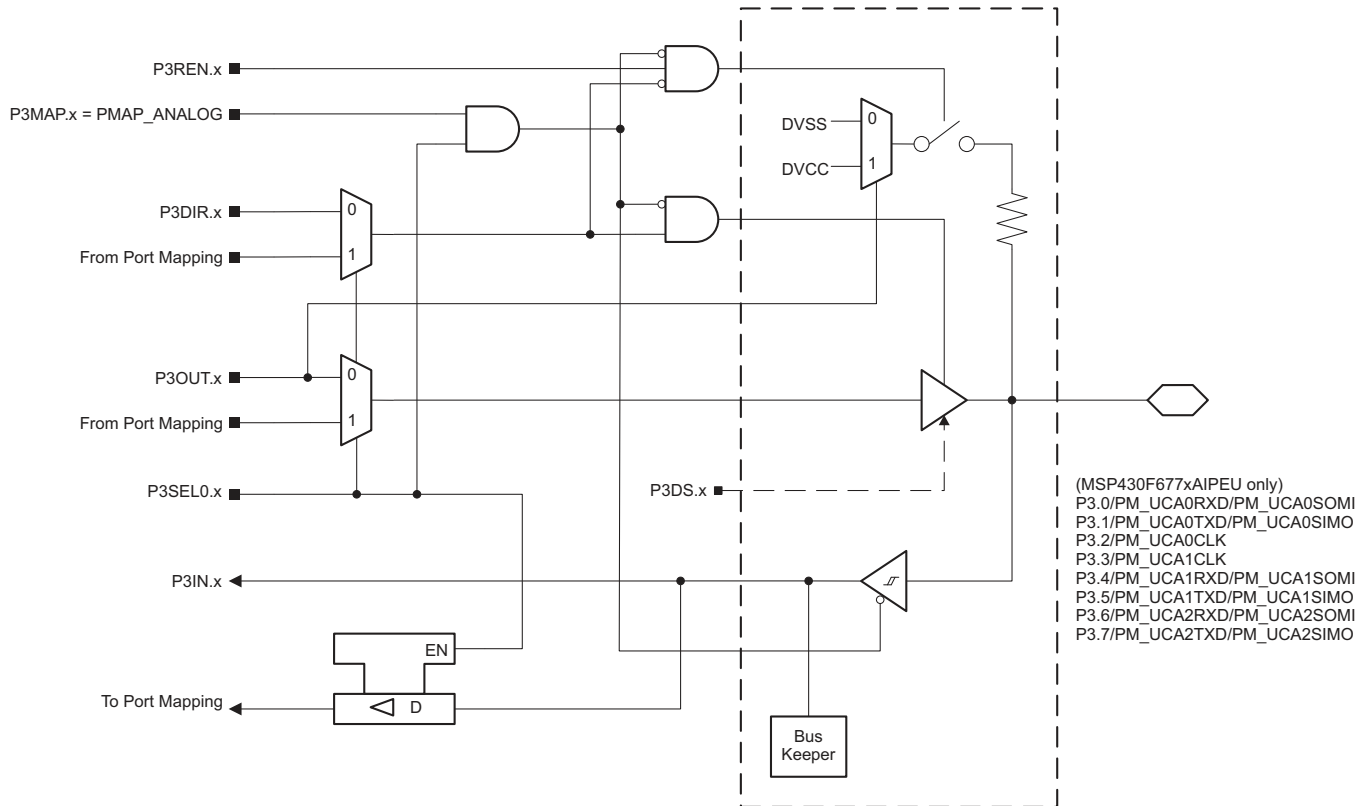

Figure 6-14. Ports P3 (P3.0 to P3.7) Diagram (PEU Package Only)

Table 6-73. Ports P3 (P3.0 to P3.7) Pin Functions (PEU Package Only)

PIN NAME (P3.x)	x	FUNCTION	CONTROL BITS OR SIGNALS ⁽¹⁾		
			P3DIR.x	P3SEL0.x	P3MAP.x
P3.0/PM_UCA0RXD/ PM_UCA0SOMI	0	P3.0 (I/O)	I:0; O:1	0	X
		Mapped secondary digital function	X	1	≤ 30
		Output driver and input Schmitt trigger disabled	X	1	= 31
P3.1/PM_UCA0TXD/ PM_UCA0SIMO	1	P3.1 (I/O)	I:0; O:1	0	X
		Mapped secondary digital function	X	1	≤ 30
		Output driver and input Schmitt trigger disabled	X	1	= 31
P3.2/PM_UCA0CLK	2	P3.2 (I/O)	I:0; O:1	0	X
		Mapped secondary digital function	X	1	≤ 30
		Output driver and input Schmitt trigger disabled	X	1	= 31
P3.3/PM_UCA1CLK	3	P3.3 (I/O)	I:0; O:1	0	X
		Mapped secondary digital function	X	1	≤ 30
		Output driver and input Schmitt trigger disabled	X	1	= 31
P3.4/PM_UCA1RXD/ PM_UCA1SOMI	4	P3.4 (I/O)	I:0; O:1	0	X
		Mapped secondary digital function	X	1	≤ 30
		Output driver and input Schmitt trigger disabled	X	1	= 31
P3.5/PM_UCA1TXD/ PM_UCA1SIMO	5	P3.5 (I/O)	I:0; O:1	0	X
		Mapped secondary digital function	X	1	≤ 30
		Output driver and input Schmitt trigger disabled	X	1	= 31
P3.6/PM_UCA2RXD/ PM_UCA2SOMI	6	P3.6 (I/O)	I:0; O:1	0	X
		Mapped secondary digital function	X	1	≤ 30
		Output driver and input Schmitt trigger disabled	X	1	= 31
P3.7/PM_UCA2TXD/ PM_UCA2SIMO	7	P3.7 (I/O)	I:0; O:1	0	X
		Mapped secondary digital function	X	1	≤ 30
		Output driver and input Schmitt trigger disabled	X	1	= 31

(1) X = don't care

6.12.10 Ports P3 (P3.0) Input/Output With Schmitt Trigger (PZ Package Only)

Figure 6-15 shows the port diagram. Table 6-74 summarizes the selection of the pin functions.

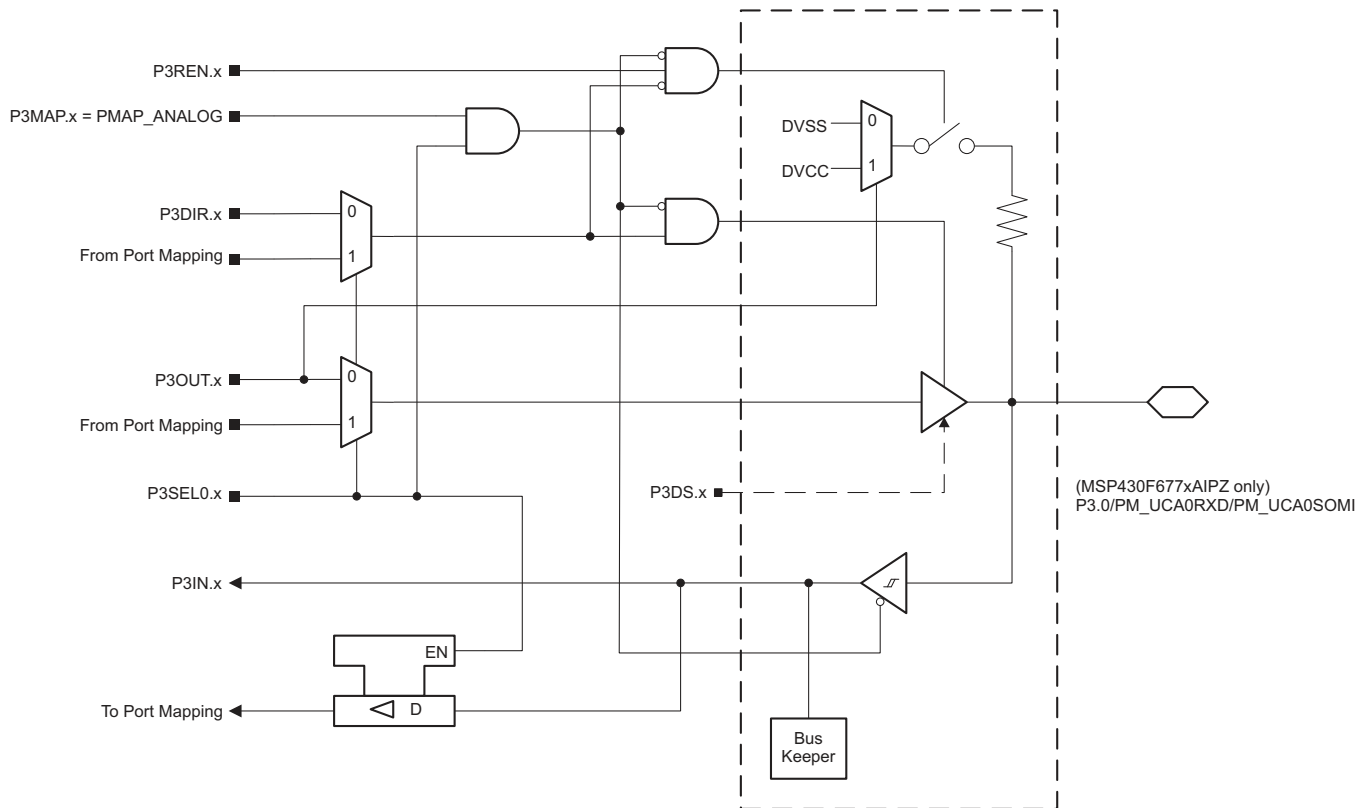

Figure 6-15. Ports P3 (P3.0) Diagram (PZ Package Only)

Table 6-74. Ports P3 (P3.0) Pin Functions (PZ Package Only)

PIN NAME (P3.x)	x	FUNCTION	CONTROL BITS OR SIGNALS ⁽¹⁾		
			P3DIR.x	P3SEL0.x	P3MAP.x
P3.0/PM_UCA0RXD/ PM_UCA0SOMI	0	P3.0 (I/O)	I:0; O:1	0	X
		Mapped secondary digital function	X	1	≤ 30
		Output driver and input Schmitt trigger disabled	X	1	= 31

(1) X = don't care

6.12.11 Ports P3 (P3.1 to P3.7) Input/Output With Schmitt Trigger (PZ Package Only)

Figure 6-16 shows the port diagram. Table 6-75 summarizes the selection of the pin functions.

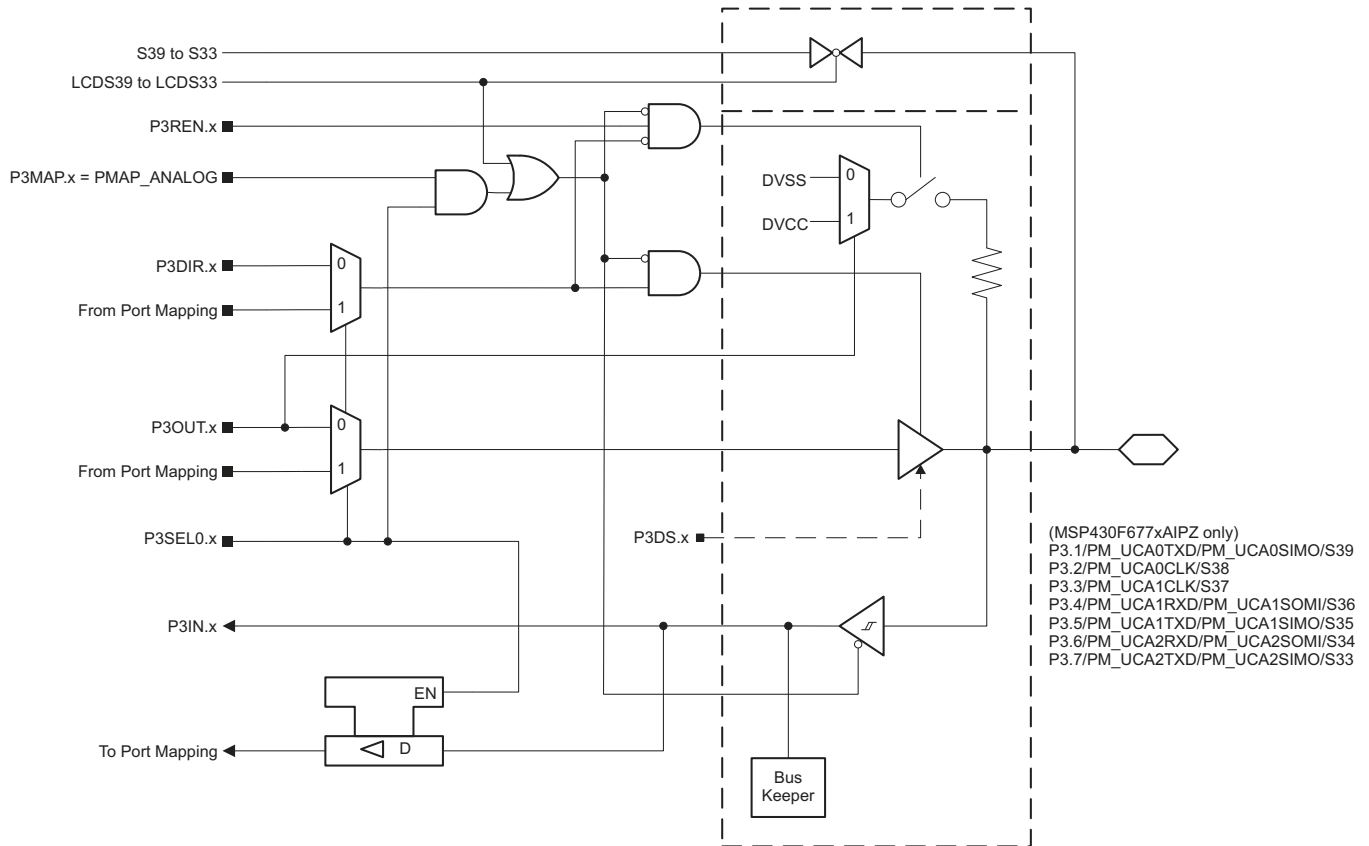

Figure 6-16. Ports P3 (P3.1 to P3.7) Diagram (PZ Package Only)

Table 6-75. Ports P3 (P3.1 to P3.7) Pin Functions (PZ Package Only)

PIN NAME (P3.x)	x	FUNCTION	CONTROL BITS OR SIGNALS ⁽¹⁾			
			P3DIR.x	P3SEL0.x	P3MAP.x	LCDS39 to LCDS33
P3.1/PM_UCA0TXD/ PM_UCA0SIMO/S39	1	P3.1 (I/O)	I:0; O:1	0	X	0
		Mapped secondary digital function	X	1	≤ 30	0
		Output driver and input Schmitt trigger disabled	X	1	= 31	0
		S39	X	X	X	1
P3.2/PM_UCA0CLK/ S38	2	P3.2 (I/O)	I:0; O:1	0	X	0
		Mapped secondary digital function	X	1	≤ 30	0
		Output driver and input Schmitt trigger disabled	X	1	= 31	0
		S38	X	X	X	1
P3.3/PM_UCA1CLK/ S37	3	P3.3 (I/O)	I:0; O:1	0	X	0
		Mapped secondary digital function	X	1	≤ 30	0
		Output driver and input Schmitt trigger disabled	X	1	= 31	0
		S37	X	X	X	1
P3.4/PM_UCA1RXD/ PM_UCA1SOMI/S36	4	P3.4 (I/O)	I:0; O:1	0	X	0
		Mapped secondary digital function	X	1	≤ 30	0
		Output driver and input Schmitt trigger disabled	X	1	= 31	0
		S36	X	X	X	1
P3.5/PM_UCA1TXD/ PM_UCA1SIMO/S35	5	P3.5 (I/O)	I:0; O:1	0	X	0
		Mapped secondary digital function	X	1	≤ 30	0
		Output driver and input Schmitt trigger disabled	X	1	= 31	0
		S35	X	X	X	1
P3.6/PM_UCA2RXD/ PM_UCA2SOMI/S34	6	P3.6 (I/O)	I:0; O:1	0	X	0
		Mapped secondary digital function	X	1	≤ 30	0
		Output driver and input Schmitt trigger disabled	X	1	= 31	0
		S34	X	X	X	1
P3.7/PM_UCA2TXD/ PM_UCA2SIMO/S33	7	P3.7 (I/O)	I:0; O:1	0	X	0
		Mapped secondary digital function	X	1	≤ 30	0
		Output driver and input Schmitt trigger disabled	X	1	= 31	0
		S33	X	X	X	1

(1) X = don't care

6.12.12 Port P4 (P4.0 to P4.7) Input/Output With Schmitt Trigger (PEU Package Only)

Figure 6-17 shows the port diagram. Table 6-76 summarizes the selection of the pin functions.

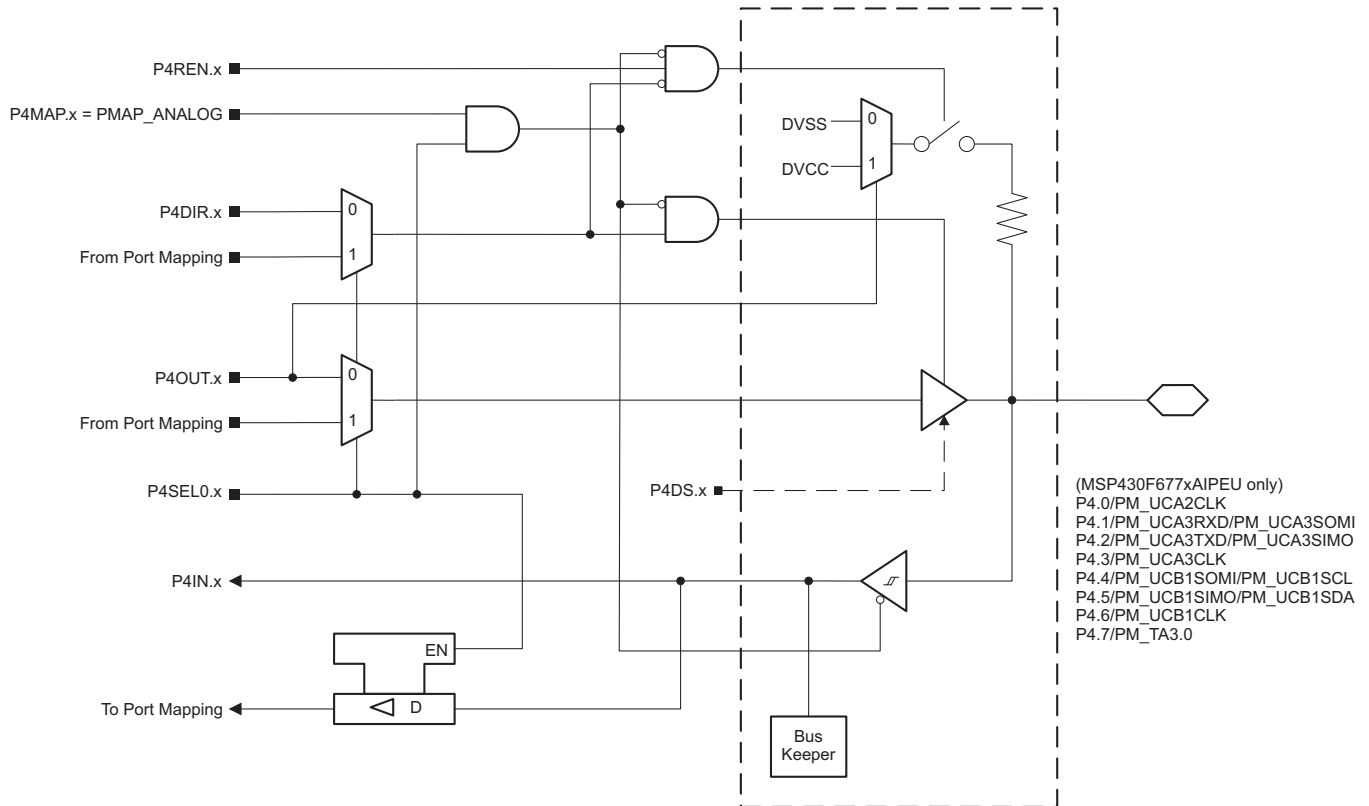

Figure 6-17. Port P4 (P4.0 to P4.7) Diagram (PEU Package Only)

Table 6-76. Port P4 (P4.0 to P4.7) Pin Functions (PEU Package Only)

PIN NAME (P4.x)	x	FUNCTION	CONTROL BITS OR SIGNALS ⁽¹⁾		
			P4DIR.x	P4SEL0.x	P4MAP.x
P4.0/PM_UCA2CLK	0	P4.0 (I/O)	I:0; O:1	0	X
		Mapped secondary digital function	X	1	≤ 30
		Output driver and input Schmitt trigger disabled	X	1	= 31
P4.1/PM_UCA3RXD/ PM_UCA3SOMI	1	P4.1 (I/O)	I:0; O:1	0	X
		Mapped secondary digital function	X	1	≤ 30
		Output driver and input Schmitt trigger disabled	X	1	= 31
P4.2/PM_UCA3TXD/ PM_UCA3SIMO	2	P4.2 (I/O)	I:0; O:1	0	X
		Mapped secondary digital function	X	1	≤ 30
		Output driver and input Schmitt trigger disabled	X	1	= 31
P4.3/PM_UCA3CLK	3	P4.3 (I/O)	I:0; O:1	0	X
		Mapped secondary digital function	X	1	≤ 30
		Output driver and input Schmitt trigger disabled	X	1	= 31
P4.4/PM_UCB1SOMI/ PM_UCB1SCL	4	P4.4 (I/O)	I:0; O:1	0	X
		Mapped secondary digital function	X	1	≤ 30
		Output driver and input Schmitt trigger disabled	X	1	= 31
P4.5/PM_UCB1SIMO/ PM_UCB1SDA	5	P4.5 (I/O)	I:0; O:1	0	X
		Mapped secondary digital function	X	1	≤ 30
		Output driver and input Schmitt trigger disabled	X	1	= 31
P4.6/PM_UCB1CLK	6	P4.6 (I/O)	I:0; O:1	0	X
		Mapped secondary digital function	X	1	≤ 30
		Output driver and input Schmitt trigger disabled	X	1	= 31
P4.7/PM_TA3.0	7	P4.7 (I/O)	I:0; O:1	0	X
		Mapped secondary digital function	X	1	≤ 30
		Output driver and input Schmitt trigger disabled	X	1	= 31

(1) X = don't care

6.12.13 Port P4 (P4.0 to P4.7) Input/Output With Schmitt Trigger (PZ Package Only)

Figure 6-18 shows the port diagram. Table 6-77 summarizes the selection of the pin functions.

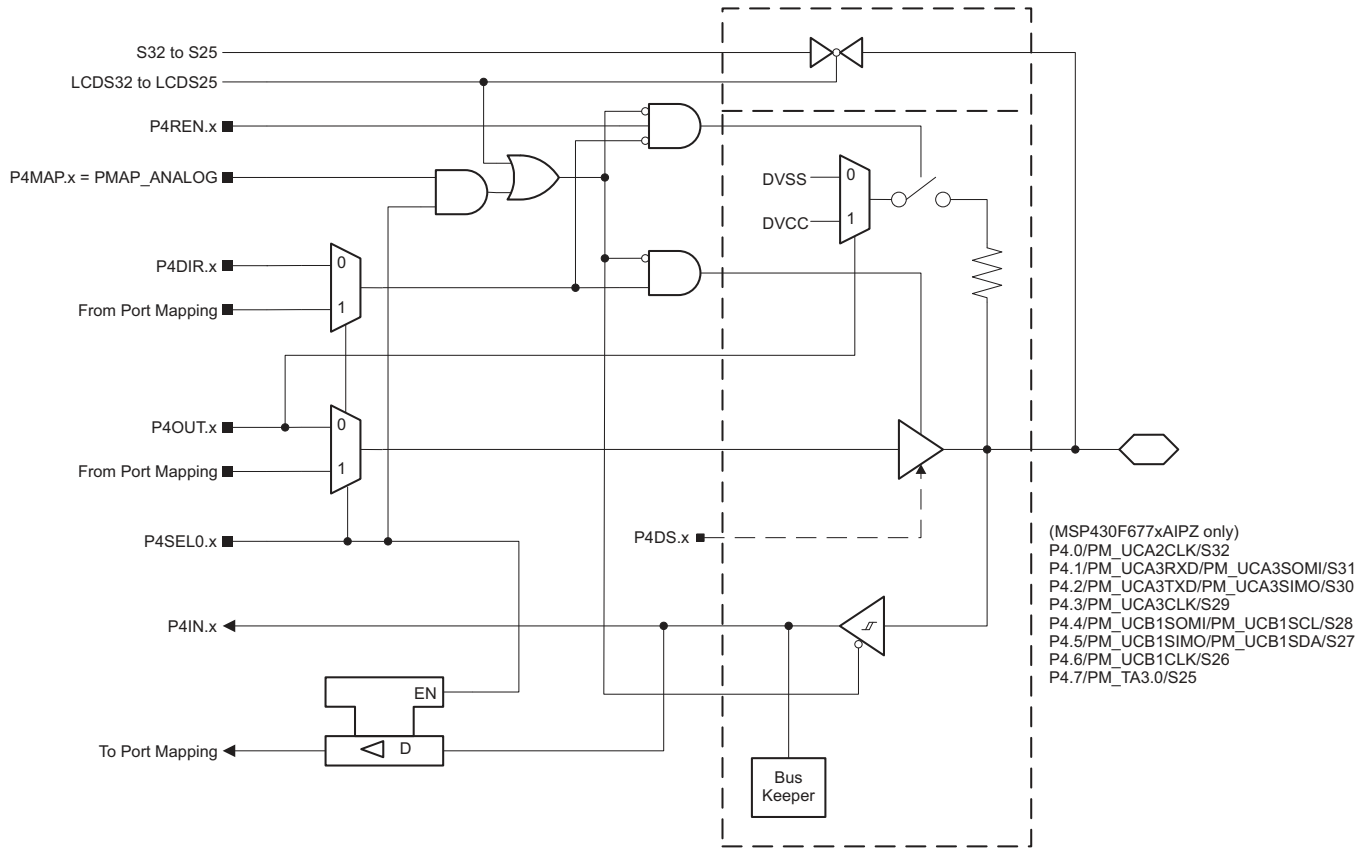

Figure 6-18. Port P4 (P4.0 to P4.7) Diagram (PZ Package Only)

Table 6-77. Port P4 (P4.0 to P4.7) Pin Functions (PZ Package Only)

PIN NAME (P4.x)	x	FUNCTION	CONTROL BITS OR SIGNALS ⁽¹⁾			
			P4DIR.x	P4SEL0.x	P4MAP.x	LCD32 to LCDS25
P4.0/PM_UCA2CLK/ S32	0	P4.0 (I/O)	I:0; O:1	0	X	0
		Mapped secondary digital function	X	1	≤ 30	0
		Output driver and input Schmitt trigger disabled	X	1	= 31	0
		S32	X	X	X	1
P4.1/PM_UCA3RXD/ PM_UCA3SOMI/S31	1	P4.1 (I/O)	I:0; O:1	0	X	0
		Mapped secondary digital function	X	1	≤ 30	0
		Output driver and input Schmitt trigger disabled	X	1	= 31	0
		S31	X	X	X	1
P4.2/PM_UCA3TXD/ PM_UCA3SIMO/S30	2	P4.2 (I/O)	I:0; O:1	0	X	0
		Mapped secondary digital function	X	1	≤ 30	0
		Output driver and input Schmitt trigger disabled	X	1	= 31	0
		S30	X	X	X	1
P4.3/PM_UCA3CLK/ S29	3	P4.3 (I/O)	I:0; O:1	0	X	0
		Mapped secondary digital function	X	1	≤ 30	0
		Output driver and input Schmitt trigger disabled	X	1	= 31	0
		S29	X	X	X	1
P4.4/ PM_UCB1SOMI/ PM_UCB1SCL/S28	4	P4.4 (I/O)	I:0; O:1	0	X	0
		Mapped secondary digital function	X	1	≤ 30	0
		Output driver and input Schmitt trigger disabled	X	1	= 31	0
		S28	X	X	X	1
P4.5/ PM_UCB1SIMO/ PM_UCB1SDA/S27	5	P4.5 (I/O)	I:0; O:1	0	X	0
		Mapped secondary digital function	X	1	≤ 30	0
		Output driver and input Schmitt trigger disabled	X	1	= 31	0
		S27	X	X	X	1
P4.6/PM_UCB1CLK/ S26	6	P4.6 (I/O)	I:0; O:1	0	X	0
		Mapped secondary digital function	X	1	≤ 30	0
		Output driver and input Schmitt trigger disabled	X	1	= 31	0
		S26	X	X	X	1
P4.7/PM_TA3.0/S25	7	P4.7 (I/O)	I:0; O:1	0	X	0
		Mapped secondary digital function	X	1	≤ 30	0
		Output driver and input Schmitt trigger disabled	X	1	= 31	0
		S25	X	X	X	1

(1) X = don't care

6.12.14 Port P5 (P5.0 to P5.3) Input/Output With Schmitt Trigger (PEU Package Only)

Figure 6-19 shows the port diagram. Table 6-78 summarizes the selection of the pin functions.

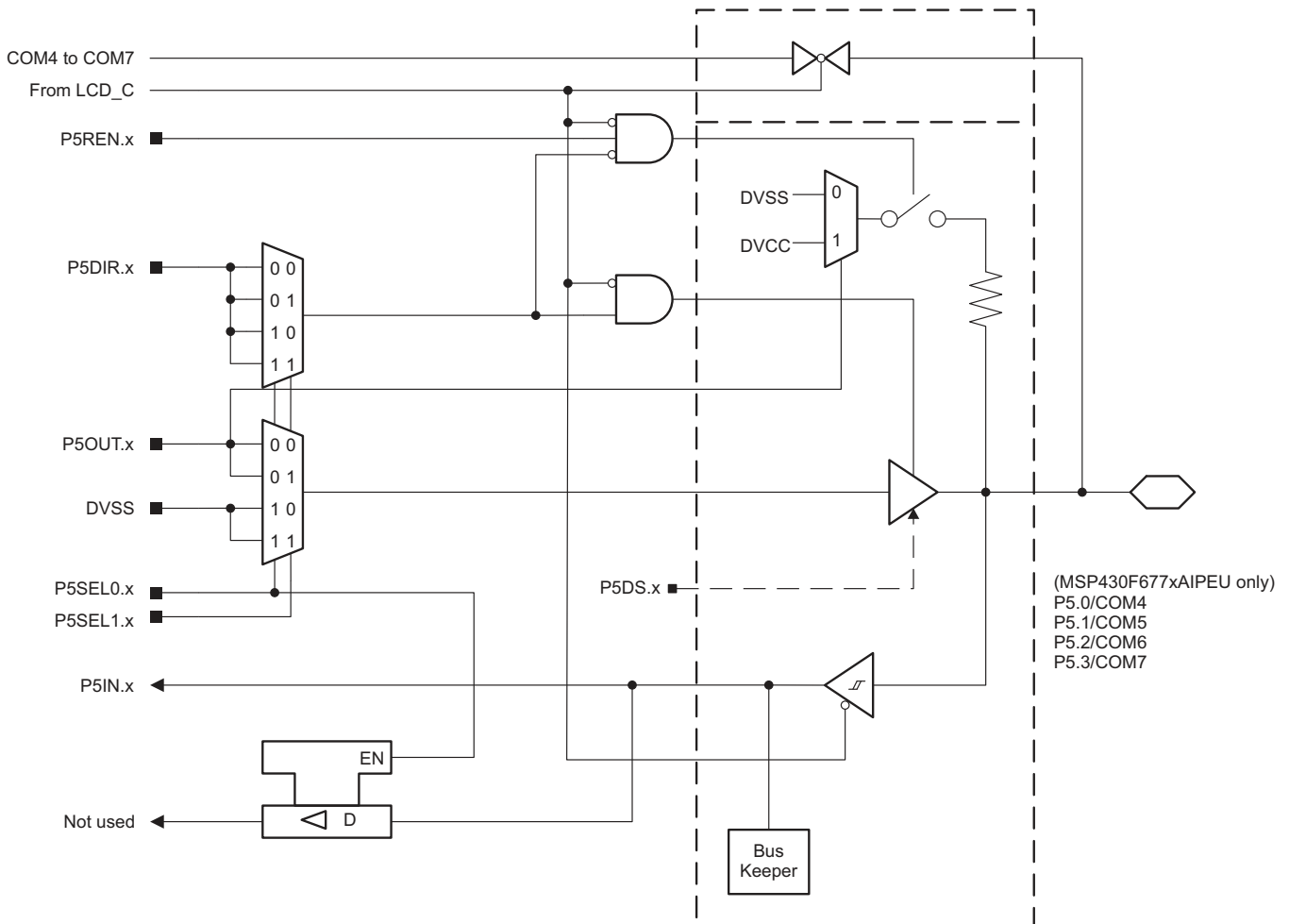

Figure 6-19. Port P5 (P5.0 to P5.3) Diagram (PEU Package Only)

Table 6-78. Port P5 (P5.0 to P5.3) Pin Functions (PEU Package Only)

PIN NAME (P5.x)	x	FUNCTION	CONTROL BITS OR SIGNALS ⁽¹⁾			
			P5DIR.x	P5SEL1.x	P5SEL0.x	COM Enable
P5.0/COM4	0	P5.0 (I/O)	I:0; O:1	X	0	0
		N/A	0	X	1	0
		DVSS	1	X	1	0
		COM4	X	X	X	1
P5.1/COM5	1	P5.1 (I/O)	I:0; O:1	X	0	0
		N/A	0	X	1	0
		DVSS	1	X	1	0
		COM5	X	X	X	1
P5.2/COM6	2	P5.2 (I/O)	I:0; O:1	X	0	0
		N/A	0	X	1	0
		DVSS	1	X	1	0
		COM6	X	X	X	1
P5.3/COM7	3	P5.3 (I/O)	I:0; O:1	X	0	0
		N/A	0	X	1	0
		DVSS	1	X	1	0
		COM7	X	X	X	1

(1) X = don't care

6.12.15 Port P5 (P5.4 to P5.6) Input/Output With Schmitt Trigger (PEU Package Only)

Figure 6-20 shows the port diagram. Table 6-79 summarizes the selection of the pin functions.

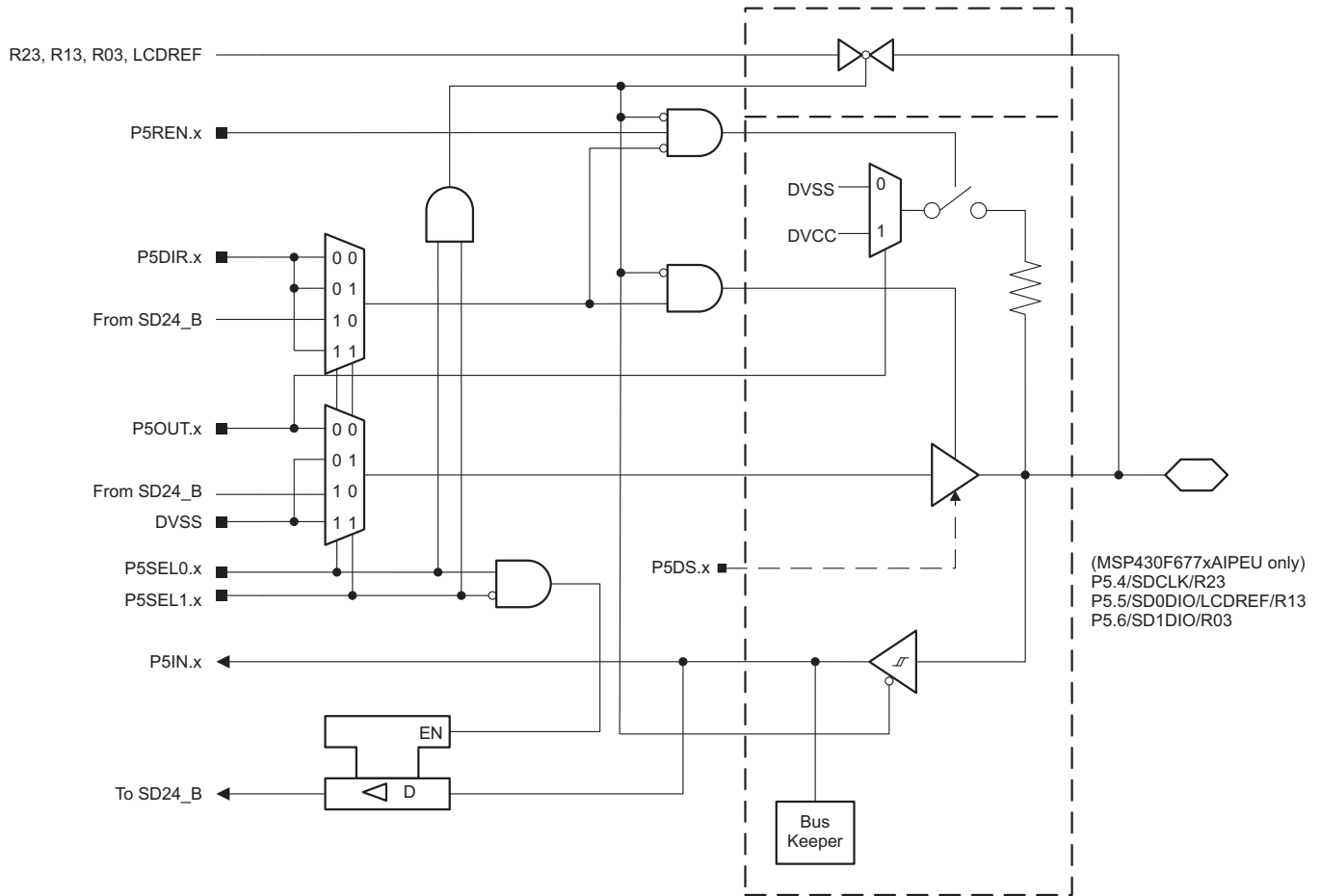

Figure 6-20. Port P5 (P5.4 to P5.6) Diagram (PEU Package Only)

Table 6-79. Port P5 (P5.4 to P5.6) Pin Functions (PEU Package Only)

PIN NAME (P5.x)	x	FUNCTION	CONTROL BITS OR SIGNALS ⁽¹⁾		
			P5DIR.x	P5SEL1.x	P5SEL0.x
P5.4/SDCLK/R23	4	P5.4 (I/O)	I:0; O:1	0	0
		Secondary digital function	X	0	1
		N/A	0	1	0
		DVSS	1	1	0
		R23	X	1	1
P5.5/SD0DIO/LCDREF/R13	5	P5.5 (I/O)	I:0; O:1	0	0
		Secondary digital function	X	0	1
		N/A	0	1	0
		DVSS	1	1	0
		LCDREF/R13	X	1	1
PT.6/SD1DIO/R03	6	P5.6 (I/O)	I:0; O:1	0	0
		Secondary digital function	X	0	1
		N/A	0	1	0
		DVSS	1	1	0
		R03	X	1	1

(1) X = don't care

6.12.16 Port P5 (P5.7) Input/Output With Schmitt Trigger (PEU Package Only)

Figure 6-21 shows the port diagram. Table 6-80 summarizes the selection of the pin functions.

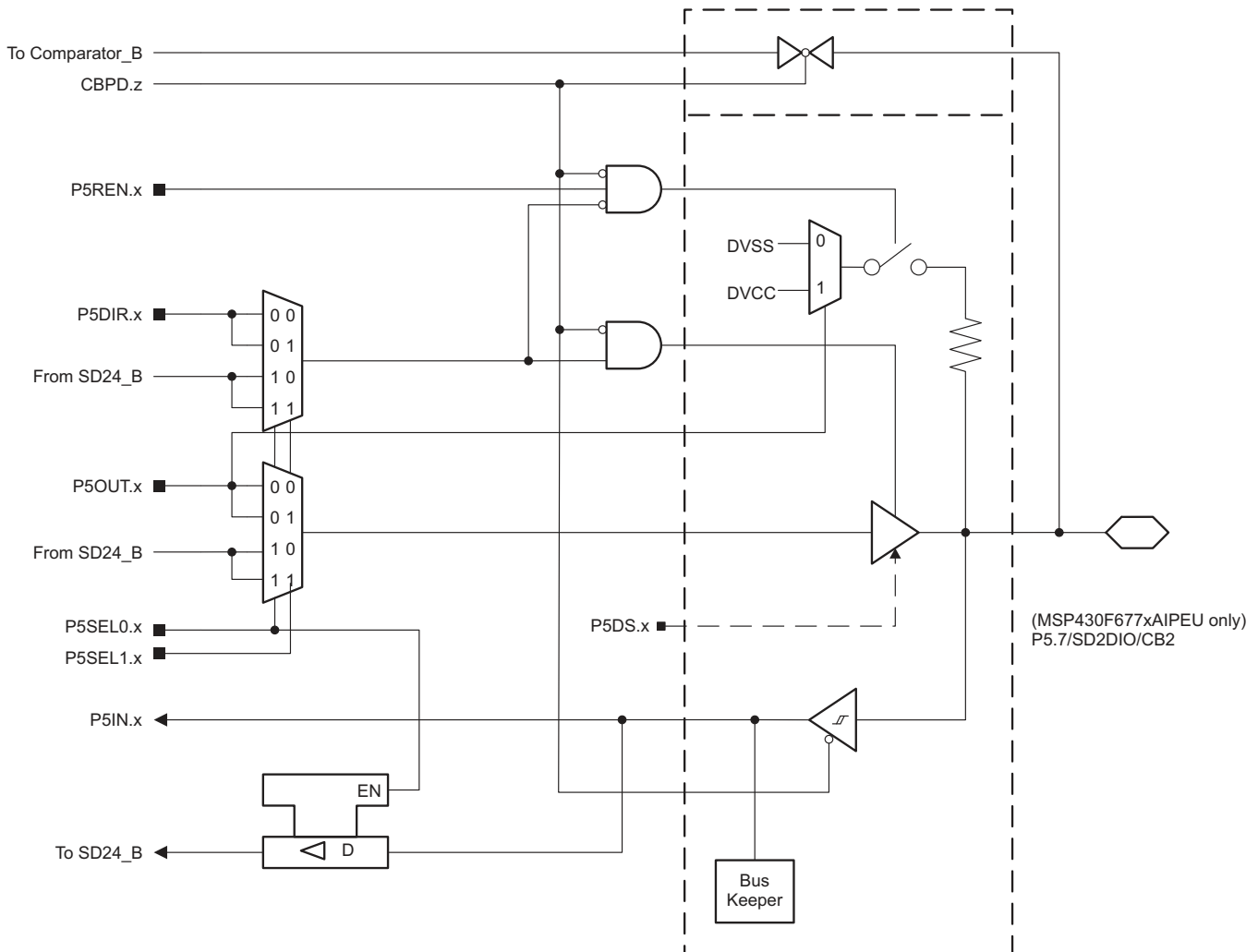

Figure 6-21. Port P5 (P5.7) Diagram (PEU Package Only)

Table 6-80. Port P5 (P5.7) Pin Function (PEU Package Only)

PIN NAME (P5.x)	x	FUNCTION	CONTROL BITS OR SIGNALS ⁽¹⁾			
			P5DIR.x	P5SEL1.x	P5SEL0.x	CBPD.z
P5.7/SD2DIO/CB2	7	P5.7 (I/O)	I:0; O:1	X	0	0
		Secondary digital function	X	X	1	0
		CB2	X	X	X	1 (z = 2)

(1) X = don't care

6.12.17 Port P5 (P5.0 to P5.7) Input/Output With Schmitt Trigger (PZ Package Only)

Figure 6-22 shows the port diagram. Table 6-81 summarizes the selection of the pin functions.

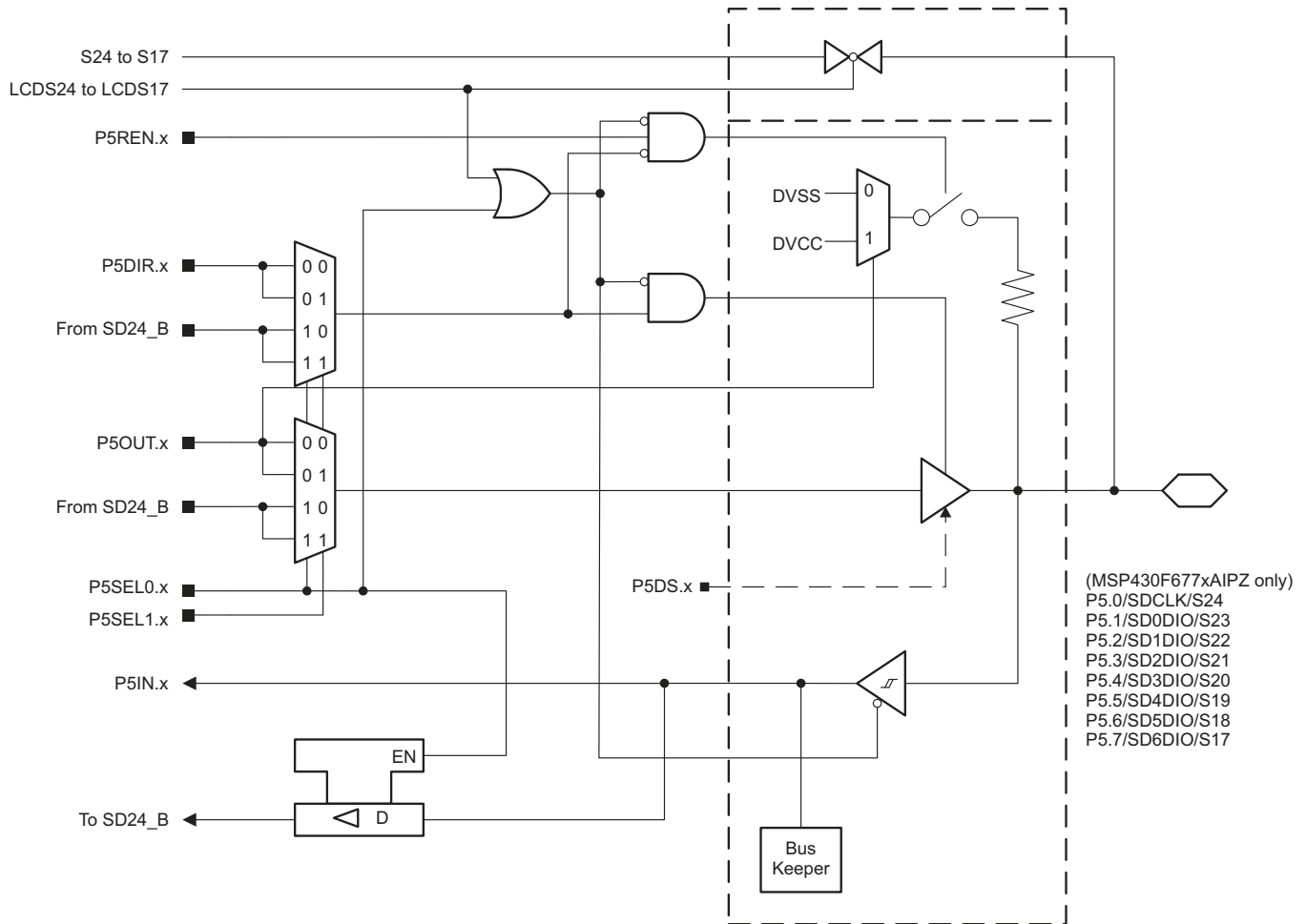

Figure 6-22. Port P5 (P5.0 to P5.7) Diagram (PZ Package Only)

Table 6-81. Port P5 (P5.0 to P5.7) Pin Function (PZ Package Only)

PIN NAME (P5.x)	x	FUNCTION	CONTROL BITS OR SIGNALS ⁽¹⁾			
			P5DIR.x	P5SEL1.x	P5SEL0.x	LCDS24 to LCDS17
P5.0/SDCLK/S24	0	P5.0 (I/O)	I:0; O:1	X	0	0
		Secondary digital function	X	X	1	0
		S24	X	X	X	1
P5.1/SD0DIO/S23	1	P5.1 (I/O)	I:0; O:1	X	0	0
		Secondary digital function	X	X	1	0
		S23	X	X	X	1
P5.2/SD1DIO/S22	2	P5.2 (I/O)	I:0; O:1	X	0	0
		Secondary digital function	X	X	1	0
		S22	X	X	X	1
P5.3/SD2DIO/S21	3	P5.3 (I/O)	I:0; O:1	X	0	0
		Secondary digital function	X	X	1	0
		S21	X	X	X	1
P5.4/SD3DIO/S20	4	P5.4 (I/O)	I:0; O:1	X	0	0
		Secondary digital function	X	X	1	0
		S20	X	X	X	1
P5.5/SD4DIO/S19	5	P5.5 (I/O)	I:0; O:1	X	0	0
		Secondary digital function	X	X	1	0
		S19	X	X	X	1
P5.6/SD5DIO/S18	6	P5.6 (I/O)	I:0; O:1	X	0	0
		Secondary digital function	X	X	1	0
		S18	X	X	X	1
P5.7/SD6DIO/S17	7	P5.7 (I/O)	I:0; O:1	X	0	0
		Secondary digital function	X	X	1	0
		S17	X	X	X	1

(1) X = don't care

6.12.18 Port P6 (P6.0) Input/Output With Schmitt Trigger (PEU Package Only)

Figure 6-23 shows the port diagram. Table 6-82 summarizes the selection of the pin functions.

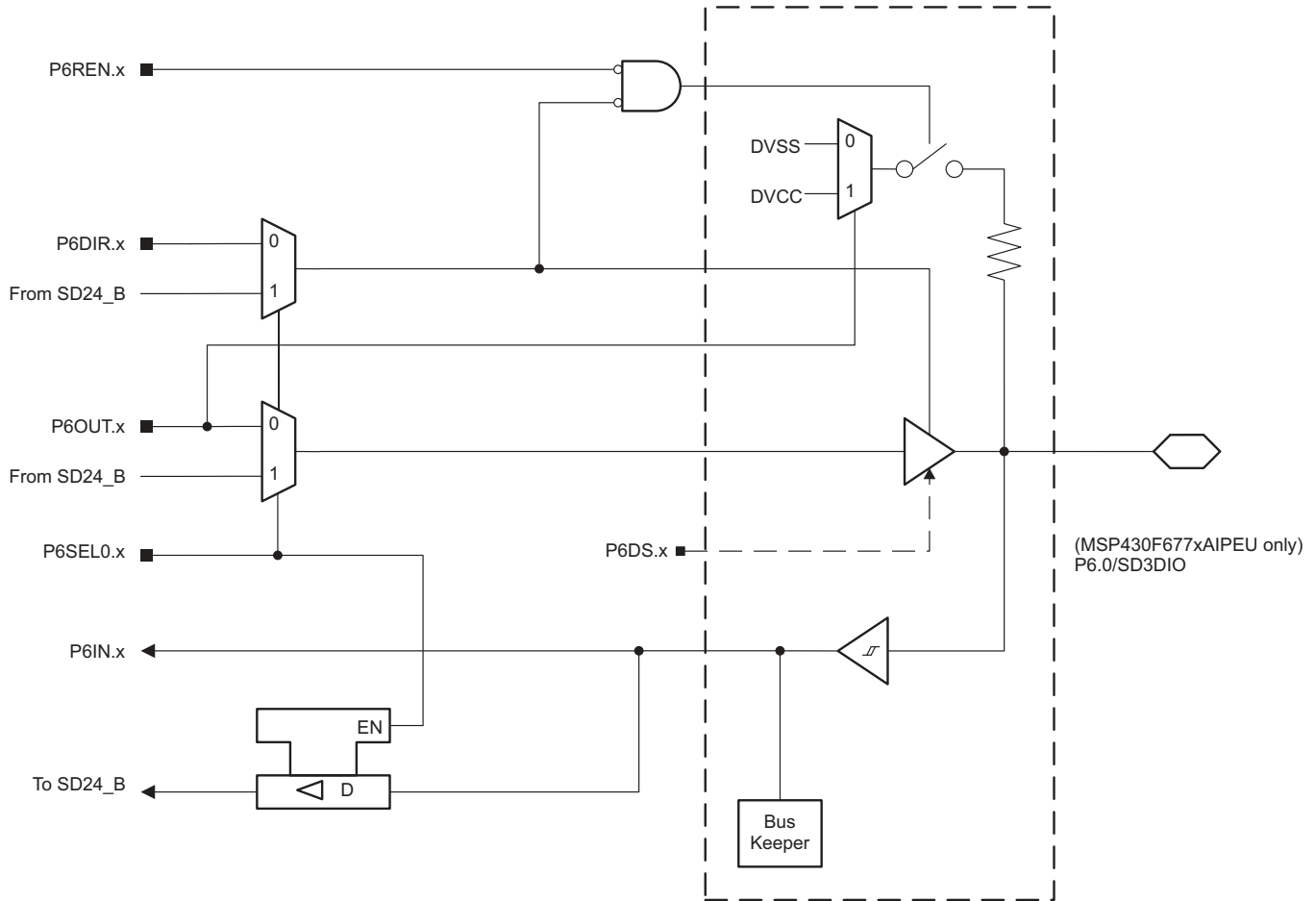

Figure 6-23. Port P6 (P6.0) Diagram (PEU Package Only)

Table 6-82. Port P6 (P6.0) Pin Functions (PEU Package Only)

PIN NAME (P6.x)	x	FUNCTION	CONTROL BITS OR SIGNALS ⁽¹⁾	
			P6DIR.x	P6SEL0.x
P6.0/SD3DIO	0	P6.0 (I/O)	I:0; O:1	0
		Secondary digital function	X	1

(1) X = don't care

6.12.19 Port P6 (P6.1 to P6.3) Input/Output With Schmitt Trigger (PEU Package Only)

Figure 6-24 shows the port diagram. Table 6-83 summarizes the selection of the pin functions.

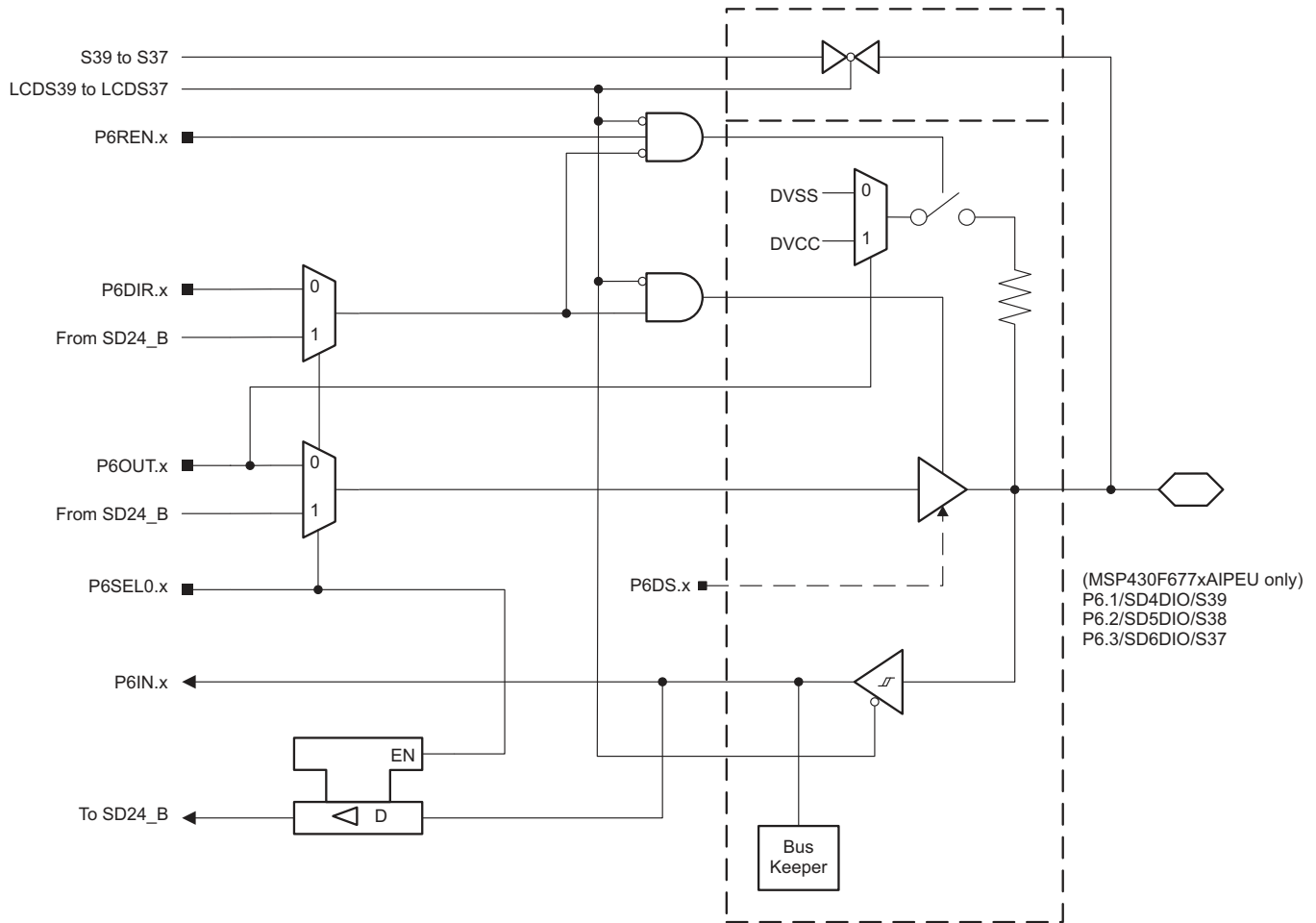

Figure 6-24. Port P6 (P6.1 to P6.3) Diagram (PEU Package Only)

Table 6-83. Port P6 (P6.1 to P6.3) Pin Functions (PEU Package Only)

PIN NAME (P6.x)	x	FUNCTION	CONTROL BITS OR SIGNALS ⁽¹⁾		
			P6DIR.x	P6SEL0.x	LCD39 to LCDS37
P6.1/SD4DIO/S39	1	P6.1 (I/O)	I:0; O:1	0	0
		Secondary digital function	X	1	0
		S39	X	X	1
P6.2/SD5DIO/S38	2	P6.2 (I/O)	I:0; O:1	0	0
		Secondary digital function	X	1	0
		S38	X	X	1
P6.3/SD6DIO/S37	3	P6.3 (I/O)	I:0; O:1	0	0
		Secondary digital function	X	1	0
		S37	X	X	1

(1) X = don't care

6.12.20 Port P6 (P6.4 to P6.7) Input/Output With Schmitt Trigger (PEU Package Only)

Figure 6-25 shows the port diagram. Table 6-84 summarizes the selection of the pin functions.

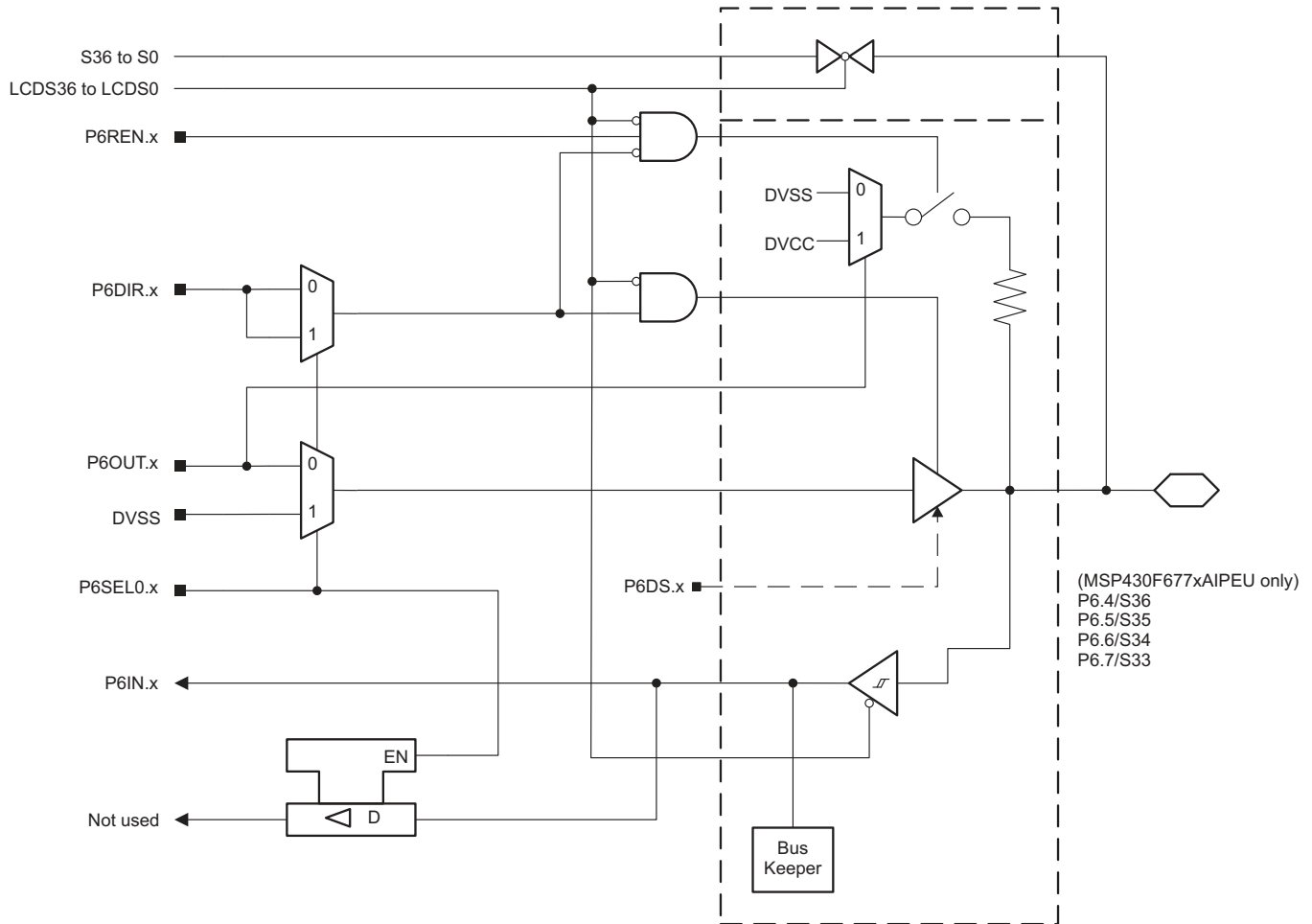

Figure 6-25. Port P6 (P6.4 to P6.7) Diagram (PEU Package Only)

Table 6-84. Port P6 (P6.4 to P6.7) Pin Functions (PEU Package Only)

PIN NAME (P6.x)	x	FUNCTION	CONTROL BITS OR SIGNALS ⁽¹⁾		
			P6DIR.x	P6SEL0.x	LCDS36 to LCDS33
P6.4/S36	4	P6.4 (I/O)	I:0; O:1	0	0
		N/A	0	1	0
		DVSS	1	1	0
		S36	X	X	1
P6.5/S35	5	P6.5 (I/O)	I:0; O:1	0	0
		N/A	0	1	0
		DVSS	1	1	0
		S35	X	X	1
P6.6/S34	6	P6.6 (I/O)	I:0; O:1	0	0
		N/A	0	1	0
		DVSS	1	1	0
		S34	X	X	1
P6.7/S33	7	P6.7 (I/O)	I:0; O:1	0	0
		N/A	0	1	0
		DVSS	1	1	0
		S33	X	X	1

(1) X = don't care

6.12.21 Port P6 (P6.0 to P6.7) Input/Output With Schmitt Trigger (PZ Package Only)

Figure 6-26 shows the port diagram. Table 6-85 summarizes the selection of the pin functions.

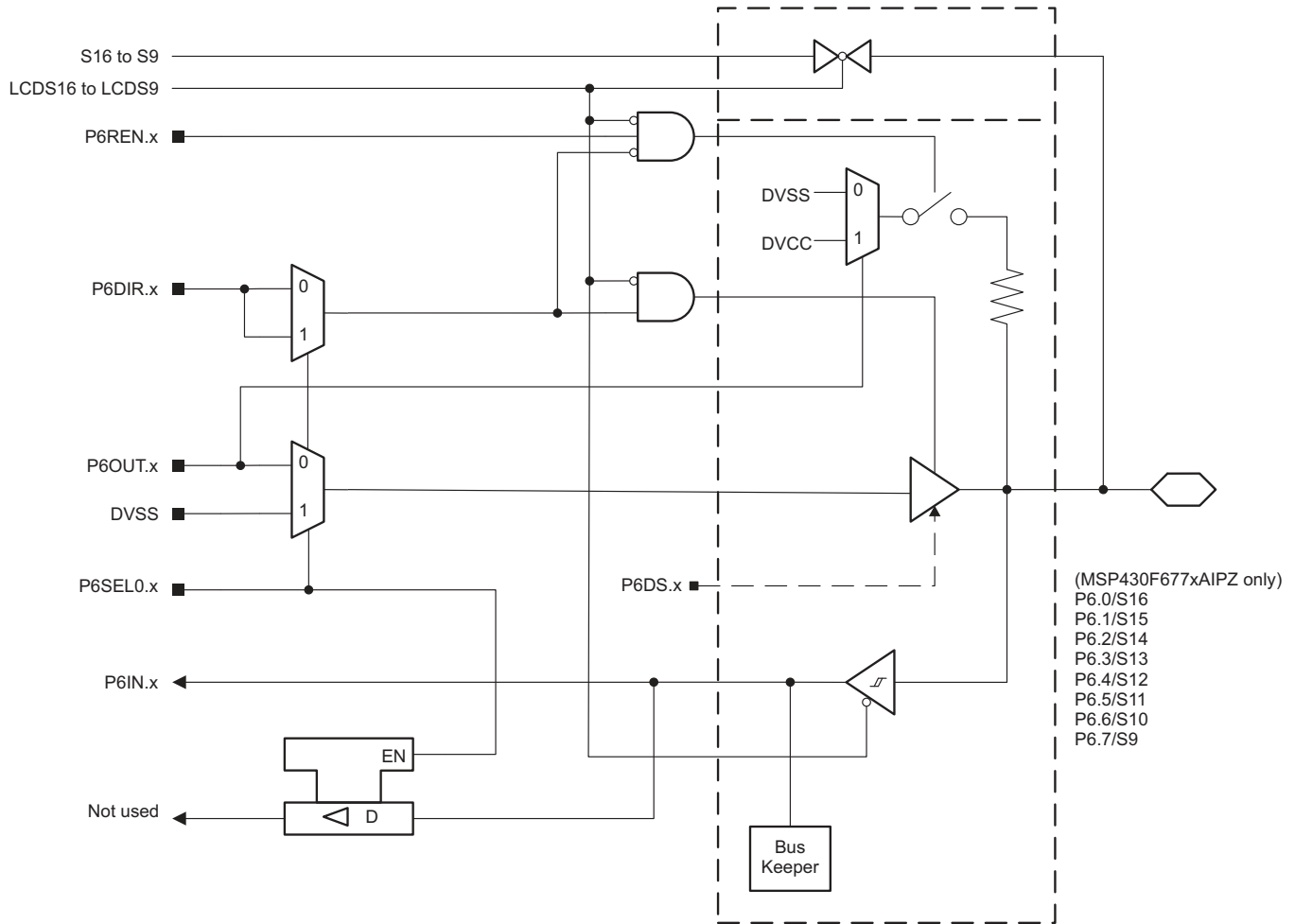

Figure 6-26. Port P6 (P6.0 to P6.7) Diagram (PZ Package Only)

Table 6-85. Port P6 (P6.0 to P6.7) Pin Functions (PZ Package Only)

PIN NAME (P6.x)	x	FUNCTION	CONTROL BITS OR SIGNALS ⁽¹⁾		
			P6DIR.x	P6SEL0.x	LCDS16 to LCDS9
P6.0/S16	0	P6.0 (I/O)	I:0; O:1	0	0
		N/A	0	1	0
		DVSS	1	1	0
		S16	X	X	1
P6.1/S15	1	P6.1 (I/O)	I:0; O:1	0	0
		N/A	0	1	0
		DVSS	1	1	0
		S15	X	X	1
P6.2/S14	2	P6.2 (I/O)	I:0; O:1	0	0
		N/A	0	1	0
		DVSS	1	1	0
		S14	X	X	1
P6.3/S13	3	P6.3 (I/O)	I:0; O:1	0	0
		N/A	0	1	0
		DVSS	1	1	0
		S13	X	X	1
P6.4/S12	4	P6.4 (I/O)	I:0; O:1	0	0
		N/A	0	1	0
		DVSS	1	1	0
		S12	X	X	1
P6.5/S11	5	P6.5 (I/O)	I:0; O:1	0	0
		N/A	0	1	0
		DVSS	1	1	0
		S11	X	X	1
P6.6/S10	6	P6.6 (I/O)	I:0; O:1	0	0
		N/A	0	1	0
		DVSS	1	1	0
		S10	X	X	1
P6.7/S9	7	P6.7 (I/O)	I:0; O:1	0	0
		N/A	0	1	0
		DVSS	1	1	0
		S9	X	X	1

(1) X = don't care

6.12.22 Port P7 (P7.0 to P7.7) Input/Output With Schmitt Trigger (PEU Package Only)

Figure 6-27 shows the port diagram. Table 6-86 summarizes the selection of the pin functions.

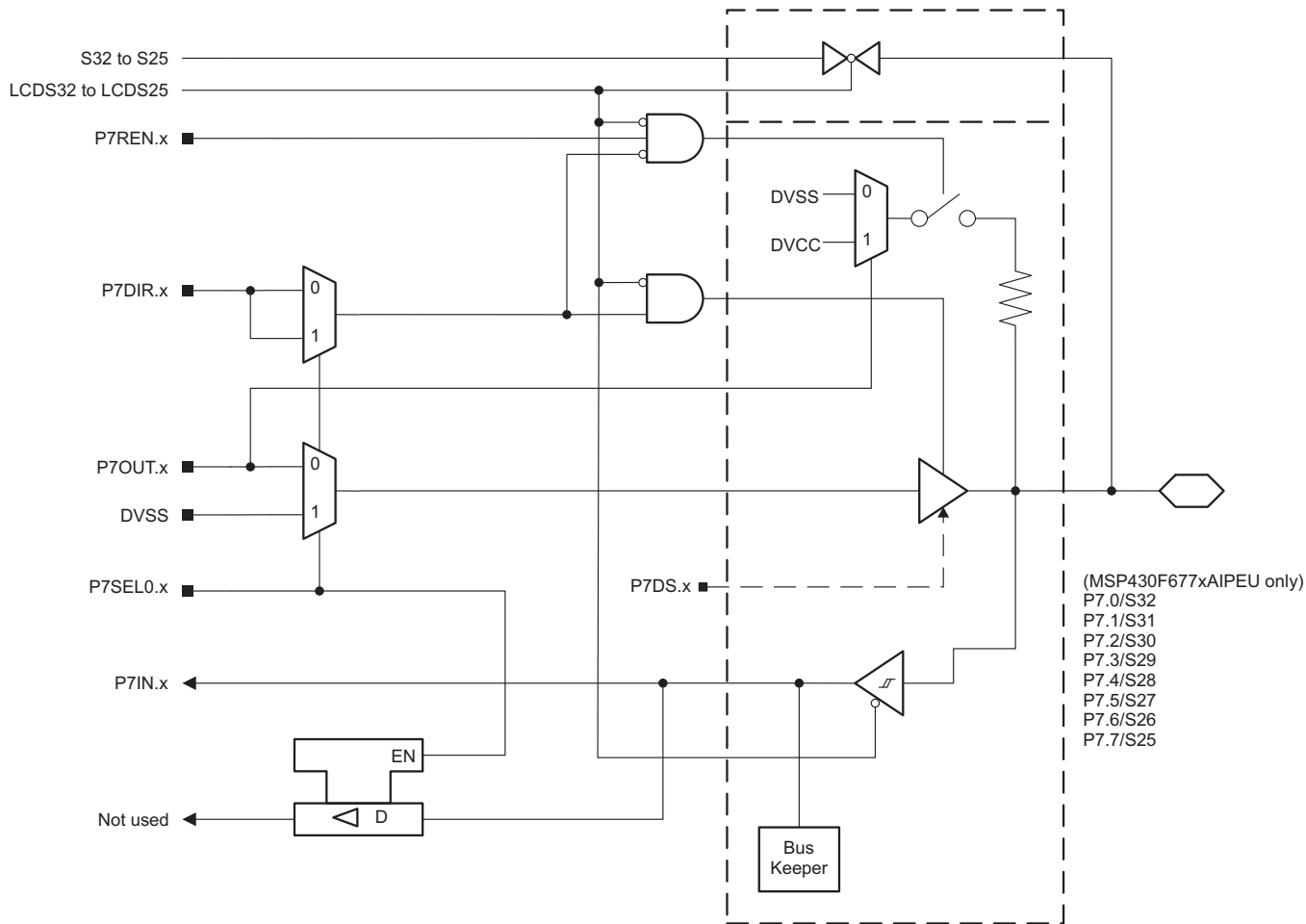

Figure 6-27. Port P7 (P7.0 to P7.7) Diagram (PEU Package Only)

Table 6-86. Port P7 (P7.0 to P7.7) Pin Functions (PEU Package Only)

PIN NAME (P7.x)	x	FUNCTION	CONTROL BITS OR SIGNALS ⁽¹⁾		
			P7DIR.x	P7SEL0.x	LCDS32 to LCDS25
P7.0/S32	0	P7.0 (I/O)	I:0; O:1	0	0
		N/A	0	1	0
		DVSS	1	1	0
		S32	X	X	1
P7.1/S31	1	P7.1 (I/O)	I:0; O:1	0	0
		N/A	0	1	0
		DVSS	1	1	0
		S31	X	X	1
P7.2/S30	2	P7.2 (I/O)	I:0; O:1	0	0
		N/A	0	1	0
		DVSS	1	1	0
		S30	X	X	1
P7.3/S29	3	P7.3 (I/O)	I:0; O:1	0	0
		N/A	0	1	0
		DVSS	1	1	0
		S29	X	X	1
P7.4/S28	4	P7.4 (I/O)	I:0; O:1	0	0
		N/A	0	1	0
		DVSS	1	1	0
		S28	X	X	1
P7.5/S27	5	P7.5 (I/O)	I:0; O:1	0	0
		N/A	0	1	0
		DVSS	1	1	0
		S27	X	X	1
P7.6/S26	6	P7.6 (I/O)	I:0; O:1	0	0
		N/A	0	1	0
		DVSS	1	1	0
		S26	X	X	1
P7.7/S25	7	P7.7 (I/O)	I:0; O:1	0	0
		N/A	0	1	0
		DVSS	1	1	0
		S25	X	X	1

(1) X = don't care

6.12.23 Port P7 (P7.0 to P7.7) Input/Output With Schmitt Trigger (PZ Package Only)

Figure 6-28 shows the port diagram. Table 6-87 summarizes the selection of the pin functions.

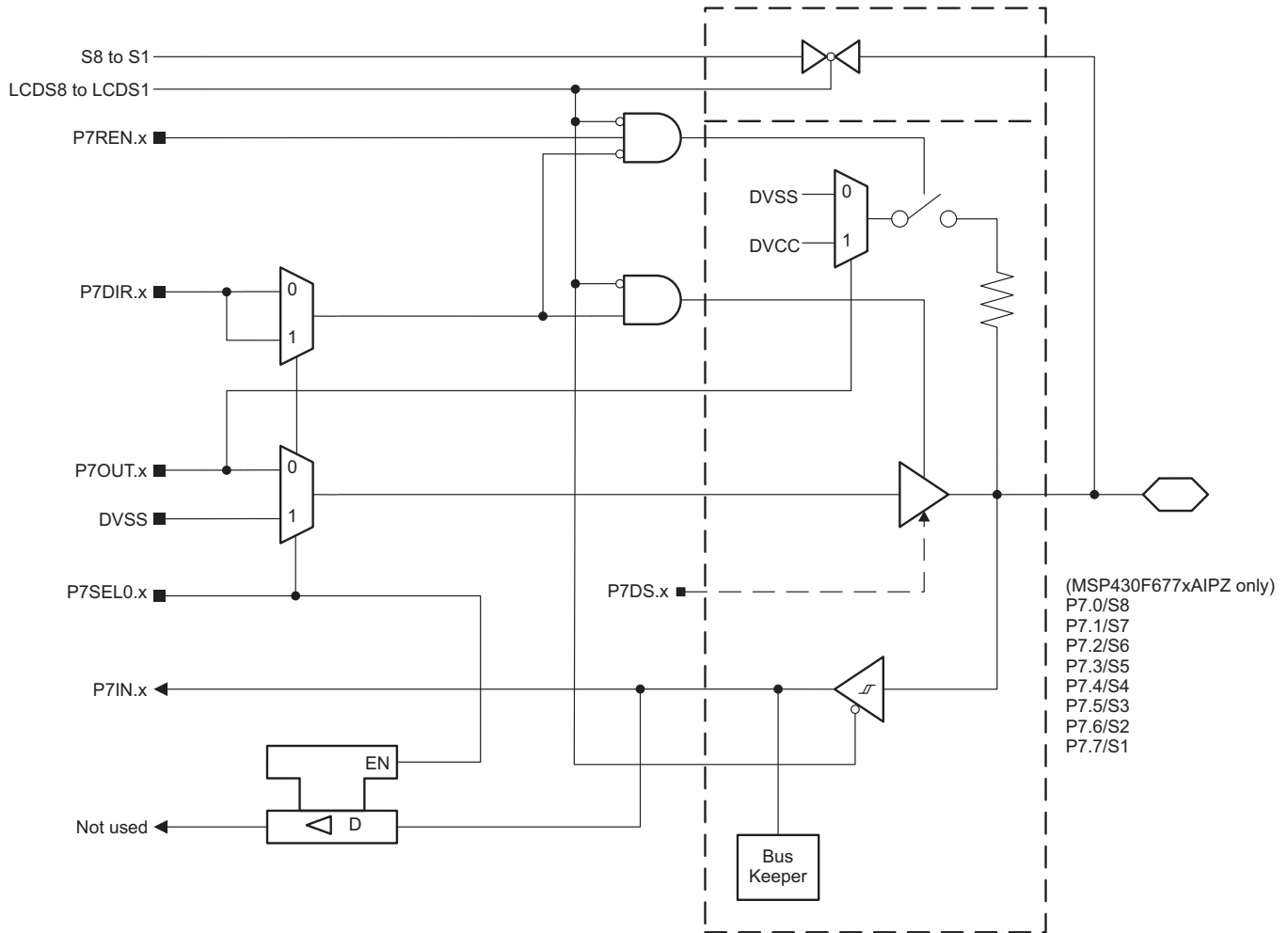

Figure 6-28. Port P7 (P7.0 to P7.7) Diagram (PZ Package Only)

Table 6-87. Port P7 (P7.0 to P7.7) Pin Functions (PZ Package Only)

PIN NAME (P7.x)	x	FUNCTION	CONTROL BITS OR SIGNALS ⁽¹⁾		
			P7DIR.x	P7SEL0.x	LCDS8 to LCDS1
P7.0/S8	0	P7.0 (I/O)	I:0; O:1	0	0
		N/A	0	1	0
		DVSS	1	1	0
		S8	X	X	1
P7.1/S7	1	P7.1 (I/O)	I:0; O:1	0	0
		N/A	0	1	0
		DVSS	1	1	0
		S7	X	X	1
P7.2/S6	2	P7.2 (I/O)	I:0; O:1	0	0
		N/A	0	1	0
		DVSS	1	1	0
		S6	X	X	1
P7.3/S5	3	P7.3 (I/O)	I:0; O:1	0	0
		N/A	0	1	0
		DVSS	1	1	0
		S5	X	X	1
P7.4/S4	4	P7.4 (I/O)	I:0; O:1	0	0
		N/A	0	1	0
		DVSS	1	1	0
		S4	X	X	1
P7.5/S3	5	P7.5 (I/O)	I:0; O:1	0	0
		N/A	0	1	0
		DVSS	1	1	0
		S3	X	X	1
P7.6/S2	6	P7.6 (I/O)	I:0; O:1	0	0
		N/A	0	1	0
		DVSS	1	1	0
		S2	X	X	1
P7.7/S1	7	P7.7 (I/O)	I:0; O:1	0	0
		N/A	0	1	0
		DVSS	1	1	0
		S1	X	X	1

(1) X = don't care

6.12.24 Port P8 (P8.0 to P8.7) Input/Output With Schmitt Trigger (PEU Package Only)

Figure 6-29 shows the port diagram. Table 6-88 summarizes the selection of the pin functions.

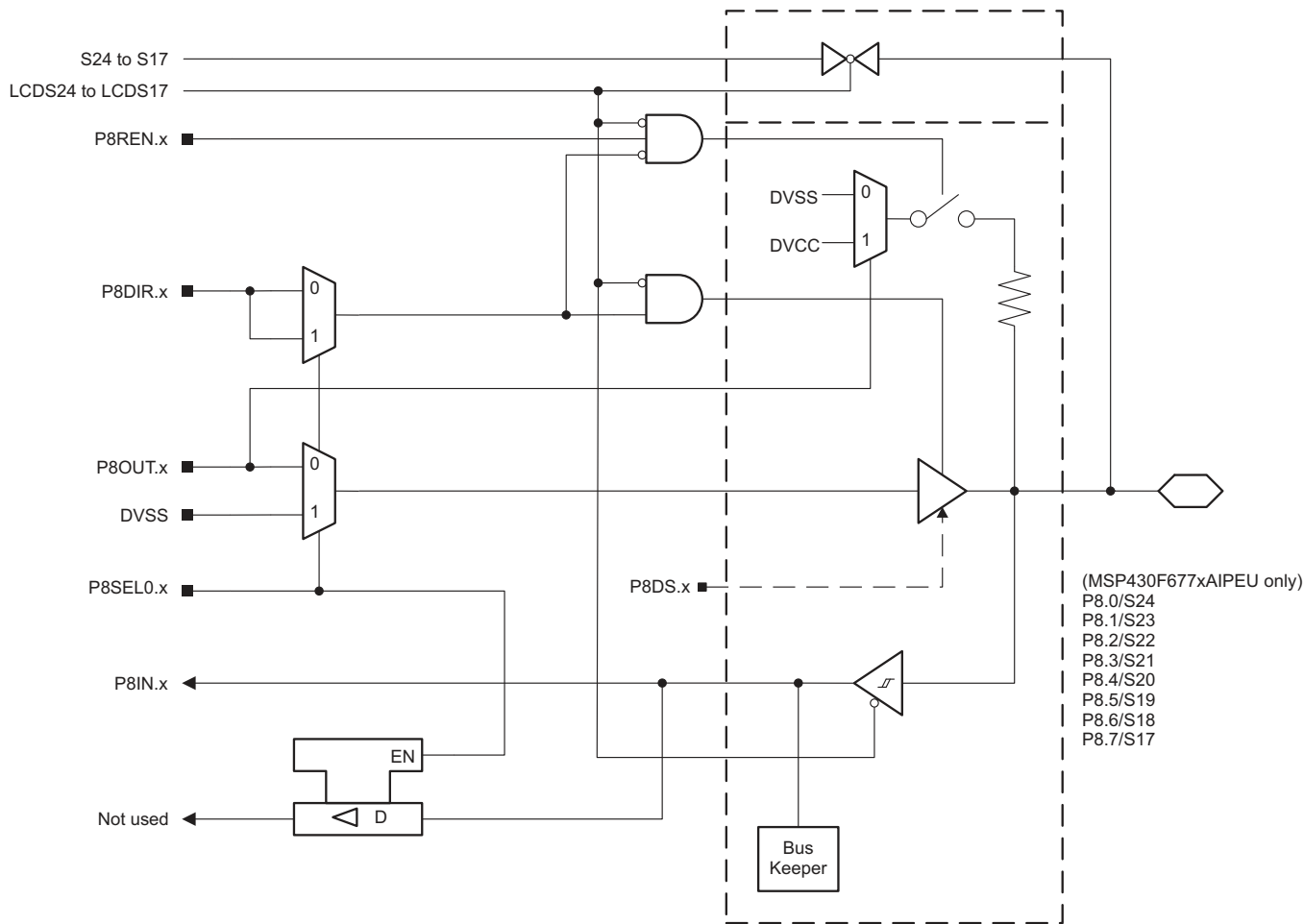

Figure 6-29. Port P8 (P8.0 to P8.7) Diagram (PEU Package Only)

Table 6-88. Port P8 (P8.0 to P8.7) Pin Functions (PEU Package Only)

PIN NAME (P8.x)	x	FUNCTION	CONTROL BITS OR SIGNALS ⁽¹⁾		
			P8DIR.x	P8SEL0.x	LCDS24 to LCDS17
P8.0/S24	0	P8.0 (I/O)	I:0; O:1	0	0
		N/A	0	1	0
		DVSS	1	1	0
		S24	X	X	1
P8.1/S23	1	P8.1 (I/O)	I:0; O:1	0	0
		N/A	0	1	0
		DVSS	1	1	0
		S23	X	X	1
P8.2/S22	2	P8.2 (I/O)	I:0; O:1	0	0
		N/A	0	1	0
		DVSS	1	1	0
		S22	X	X	1
P8.3/S21	3	P8.3 (I/O)	I:0; O:1	0	0
		N/A	0	1	0
		DVSS	1	1	0
		S21	X	X	1
P8.4/S20	4	P8.4 (I/O)	I:0; O:1	0	0
		N/A	0	1	0
		DVSS	1	1	0
		S20	X	X	1
P8.5/S19	5	P8.5 (I/O)	I:0; O:1	0	0
		N/A	0	1	0
		DVSS	1	1	0
		S19	X	X	1
P8.6/S18	6	P8.6 (I/O)	I:0; O:1	0	0
		N/A	0	1	0
		DVSS	1	1	0
		S18	X	X	1
P8.7/S17	7	P8.7 (I/O)	I:0; O:1	0	0
		N/A	0	1	0
		DVSS	1	1	0
		S17	X	X	1

(1) X = don't care

6.12.25 Port P8 (P8.0) Input/Output With Schmitt Trigger (PZ Package Only)

Figure 6-30 shows the port diagram. Table 6-89 summarizes the selection of the pin functions.

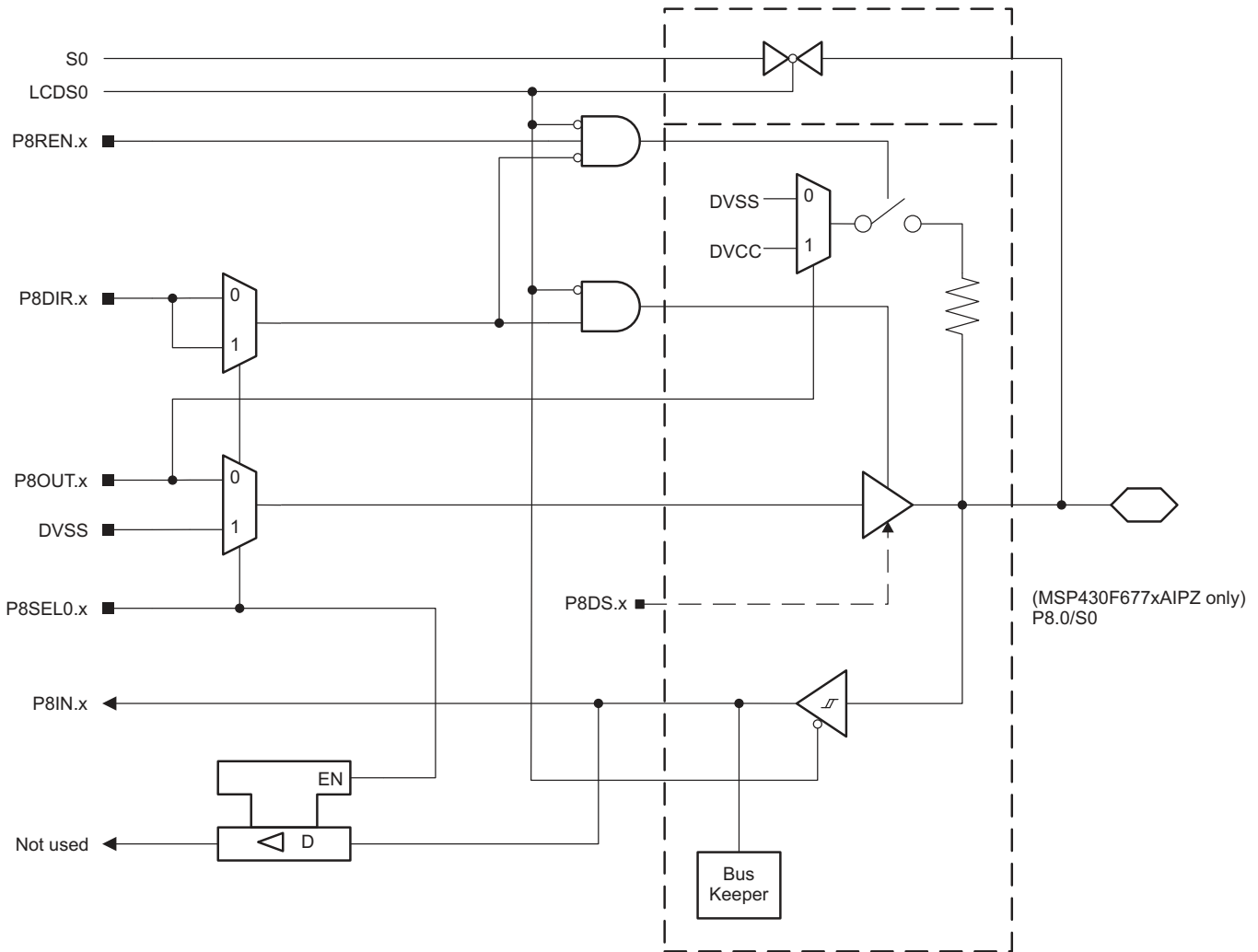

Figure 6-30. Port P8 (P8.0) Diagram (PZ Package Only)

Table 6-89. Port P8 (P8.0) Pin Functions (PZ Package Only)

PIN NAME (P8.x)	x	FUNCTION	CONTROL BITS OR SIGNALS ⁽¹⁾		
			P8DIR.x	P8SEL0.x	LCDS0
P8.0/S0	0	P8.0 (I/O)	I:0; O:1	0	0
		N/A	0	1	0
		DVSS	1	1	0
		S0	X	X	1

(1) X = don't care

6.12.26 Port P8 (P8.1) Input/Output With Schmitt Trigger (PZ Package Only)

Figure 6-31 shows the port diagram. Table 6-90 summarizes the selection of the pin functions.

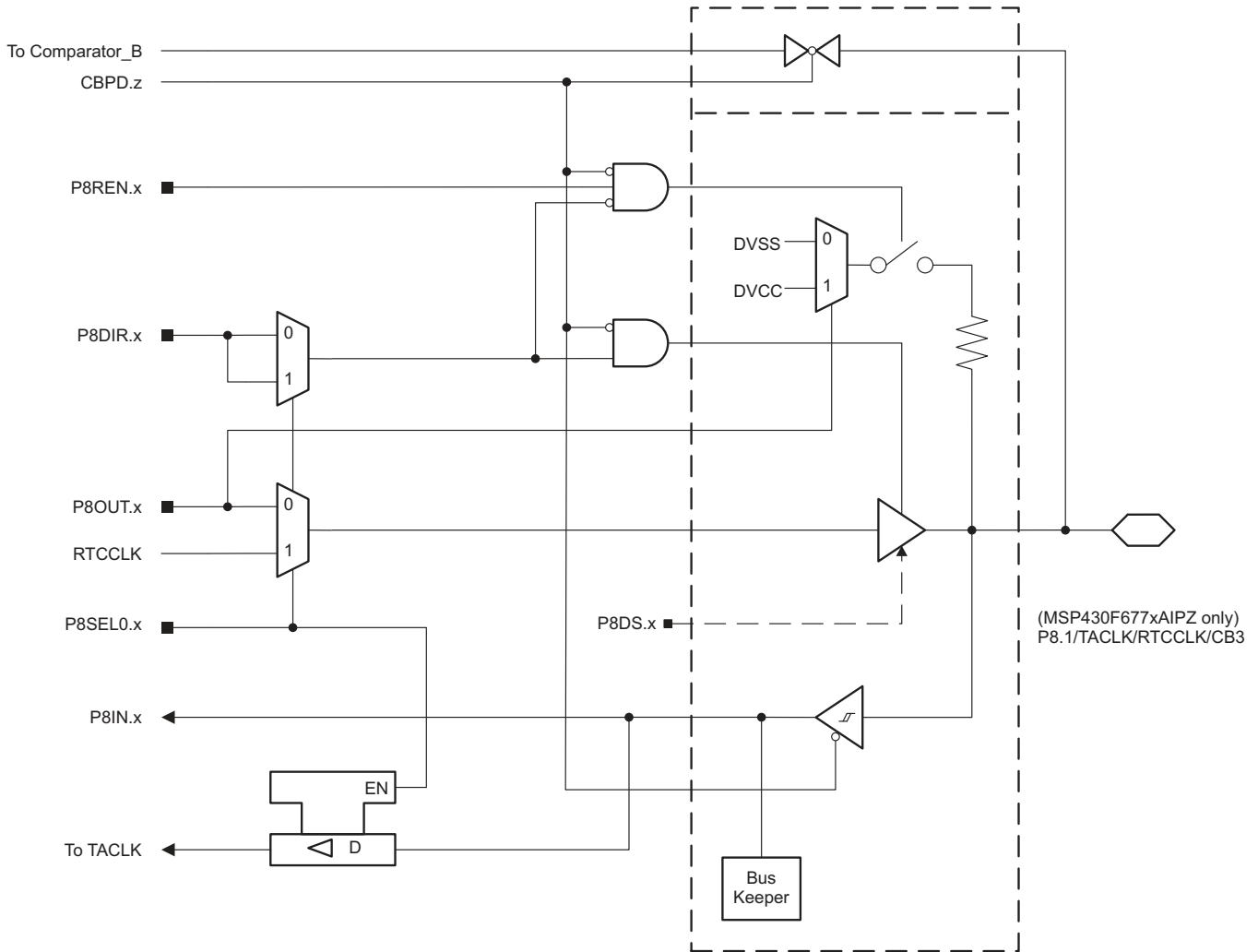

Figure 6-31. Port P8 (P8.1) Diagram (PZ Package Only)

Table 6-90. Port P8 (P8.1) Pin Functions (PZ Package Only)

PIN NAME (P8.x)	x	FUNCTION	CONTROL BITS OR SIGNALS ⁽¹⁾		
			P8DIR.x	P8SEL0.x	CBPD.z
P8.1/TACLK/RTCCLK/CB3	1	P8.1 (I/O)	I:0; O:1	0	0
		TACLK	0	1	0
		RTCCLK	1	1	0
		CB3	X	X	1 (z = 3)

(1) X = don't care

6.12.27 Port P9 (P9.0 to P9.7) Input/Output With Schmitt Trigger (PEU Package Only)

Figure 6-32 shows the port diagram. Table 6-91 summarizes the selection of the pin functions.

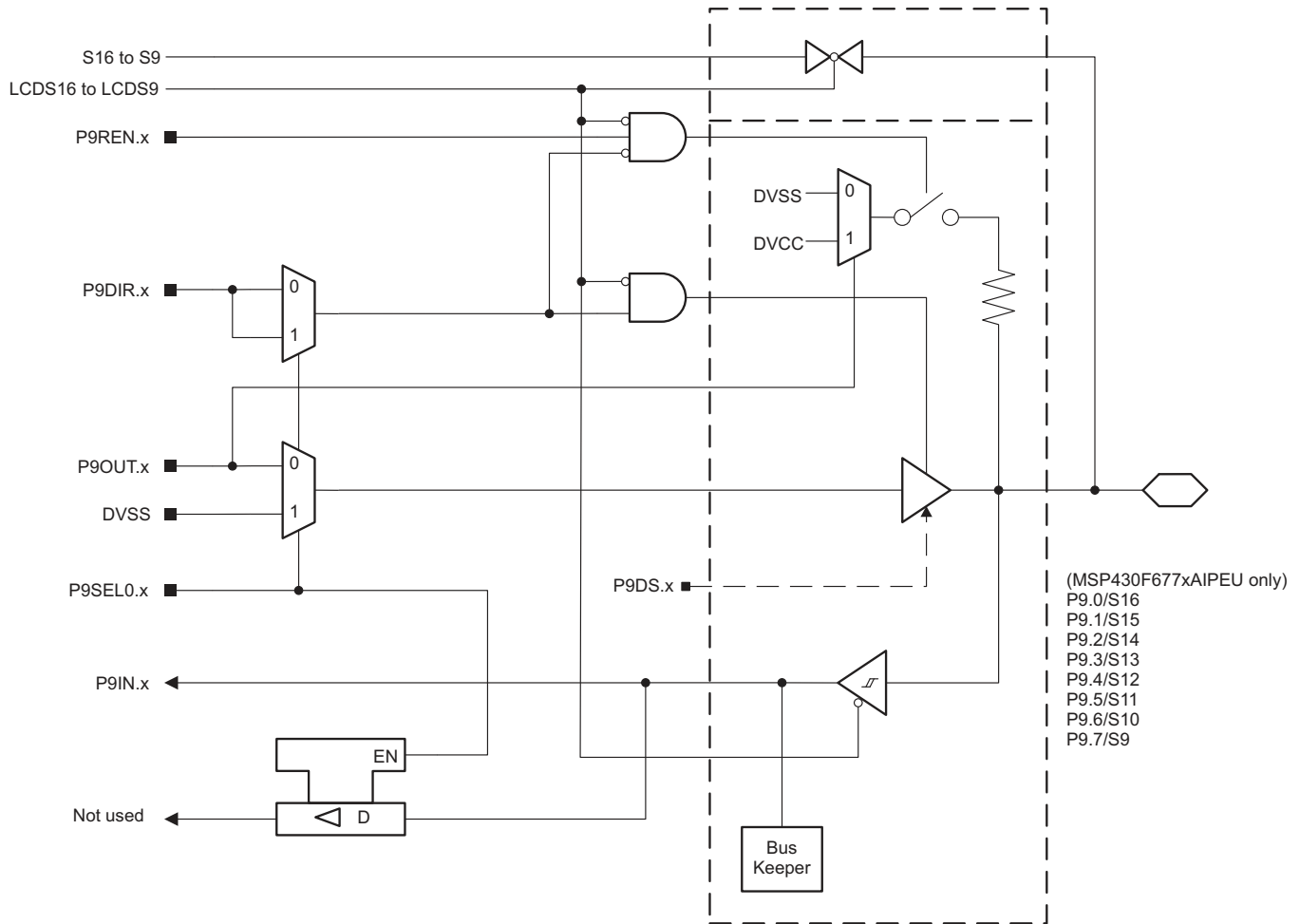

Figure 6-32. Port P9 (P9.0 to P9.7) Diagram (PEU Package Only)

Table 6-91. Port P9 (P9.0 to P9.7) Pin Functions (PEU Package Only)

PIN NAME (P9.x)	x	FUNCTION	CONTROL BITS OR SIGNALS ⁽¹⁾		
			P9DIR.x	P9SEL0.x	LCDS16 to LCDS9
P9.0/S16	0	P9.0 (I/O)	I:0; O:1	0	0
		N/A	0	1	0
		DVSS	1	1	0
		S16	X	X	1
P9.1/S15	1	P9.1 (I/O)	I:0; O:1	0	0
		N/A	0	1	0
		DVSS	1	1	0
		S15	X	X	1
P9.2/S14	2	P9.2 (I/O)	I:0; O:1	0	0
		N/A	0	1	0
		DVSS	1	1	0
		S14	X	X	1
P9.3/S13	3	P9.3 (I/O)	I:0; O:1	0	0
		N/A	0	1	0
		DVSS	1	1	0
		S13	X	X	1
P9.4/S12	4	P9.4 (I/O)	I:0; O:1	0	0
		N/A	0	1	0
		DVSS	1	1	0
		S12	X	X	1
P9.5/S11	5	P9.5 (I/O)	I:0; O:1	0	0
		N/A	0	1	0
		DVSS	1	1	0
		S11	X	X	1
P9.6/S10	6	P9.6 (I/O)	I:0; O:1	0	0
		N/A	0	1	0
		DVSS	1	1	0
		S10	X	X	1
P9.7/S9	7	P9.7 (I/O)	I:0; O:1	0	0
		N/A	0	1	0
		DVSS	1	1	0
		S9	X	X	1

(1) X = don't care

6.12.28 Port P10 (P10.0 to P10.7) Input/Output With Schmitt Trigger (PEU Package Only)

Figure 6-33 shows the port diagram. Table 6-92 summarizes the selection of the pin functions.

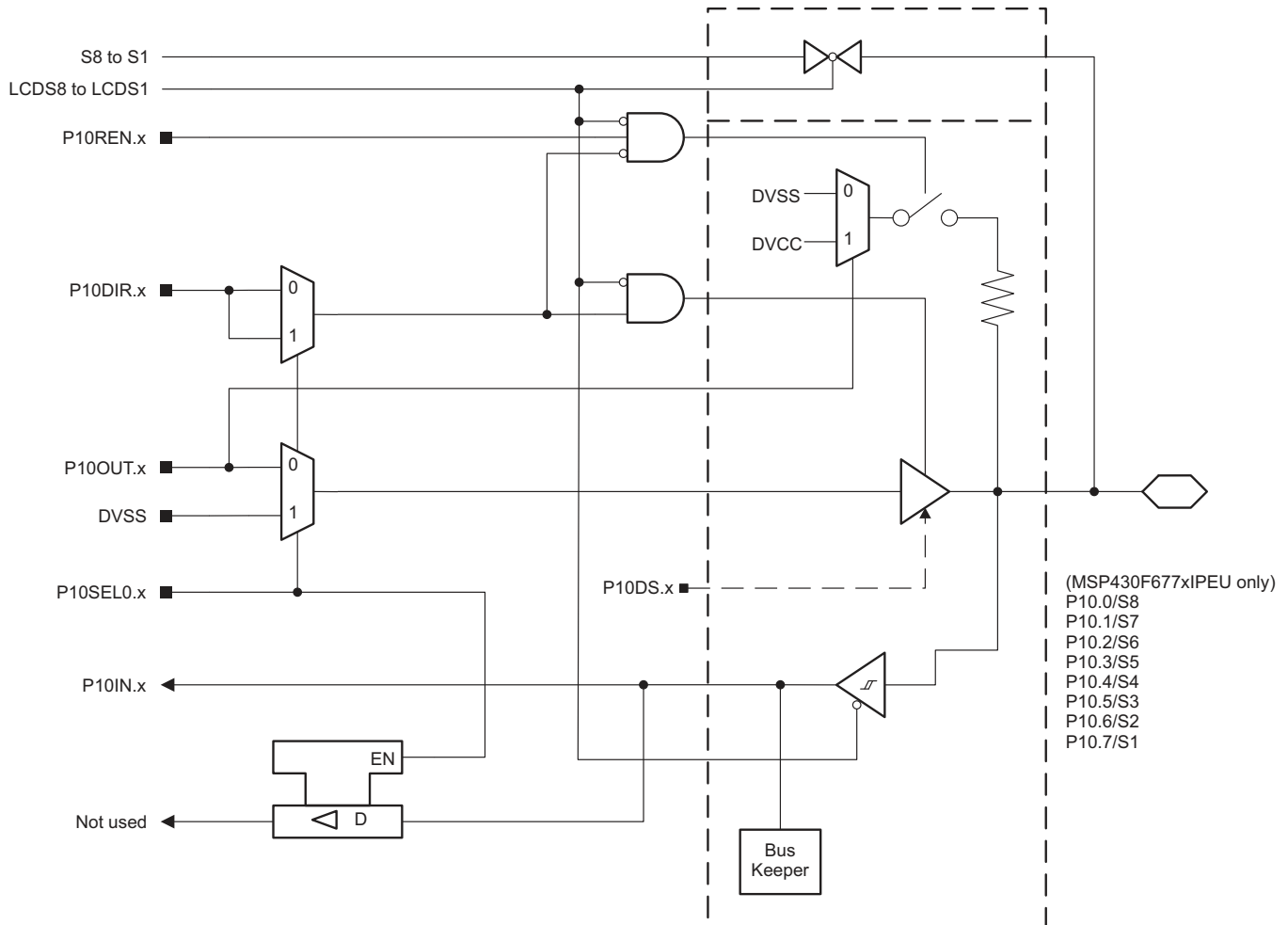

Figure 6-33. Port P10 (P10.0 to P10.7) Diagram (PEU Package Only)

Table 6-92. Port P10 (P10.0 to P10.7) Pin Functions (PEU Package Only)

PIN NAME (P10.x)	x	FUNCTION	CONTROL BITS OR SIGNALS ⁽¹⁾		
			P10DIR.x	P10SEL0.x	LCDS8 to LCDS1
P10.0/S8	0	P10.0 (I/O)	I:0; O:1	0	0
		N/A	0	1	0
		DVSS	1	1	0
		S8	X	X	1
P10.1/S7	1	P10.1 (I/O)	I:0; O:1	0	0
		N/A	0	1	0
		DVSS	1	1	0
		S7	X	X	1
P10.2/S6	2	P10.2 (I/O)	I:0; O:1	0	0
		N/A	0	1	0
		DVSS	1	1	0
		S6	X	X	1
P10.3/S5	3	P10.3 (I/O)	I:0; O:1	0	0
		N/A	0	1	0
		DVSS	1	1	0
		S5	X	X	1
P10.4/S4	4	P10.4 (I/O)	I:0; O:1	0	0
		N/A	0	1	0
		DVSS	1	1	0
		S4	X	X	1
P10.5/S3	5	P10.5 (I/O)	I:0; O:1	0	0
		N/A	0	1	0
		DVSS	1	1	0
		S3	X	X	1
P10.6/S2	6	P10.6 (I/O)	I:0; O:1	0	0
		N/A	0	1	0
		DVSS	1	1	0
		S2	X	X	1
P10.7/S1	7	P10.7 (I/O)	I:0; O:1	0	0
		N/A	0	1	0
		DVSS	1	1	0
		S1	X	X	1

(1) X = don't care

6.12.29 Port P11 (P11.0) Input/Output With Schmitt Trigger (PEU Package Only)

Figure 6-34 shows the port diagram. Table 6-93 summarizes the selection of the pin functions.

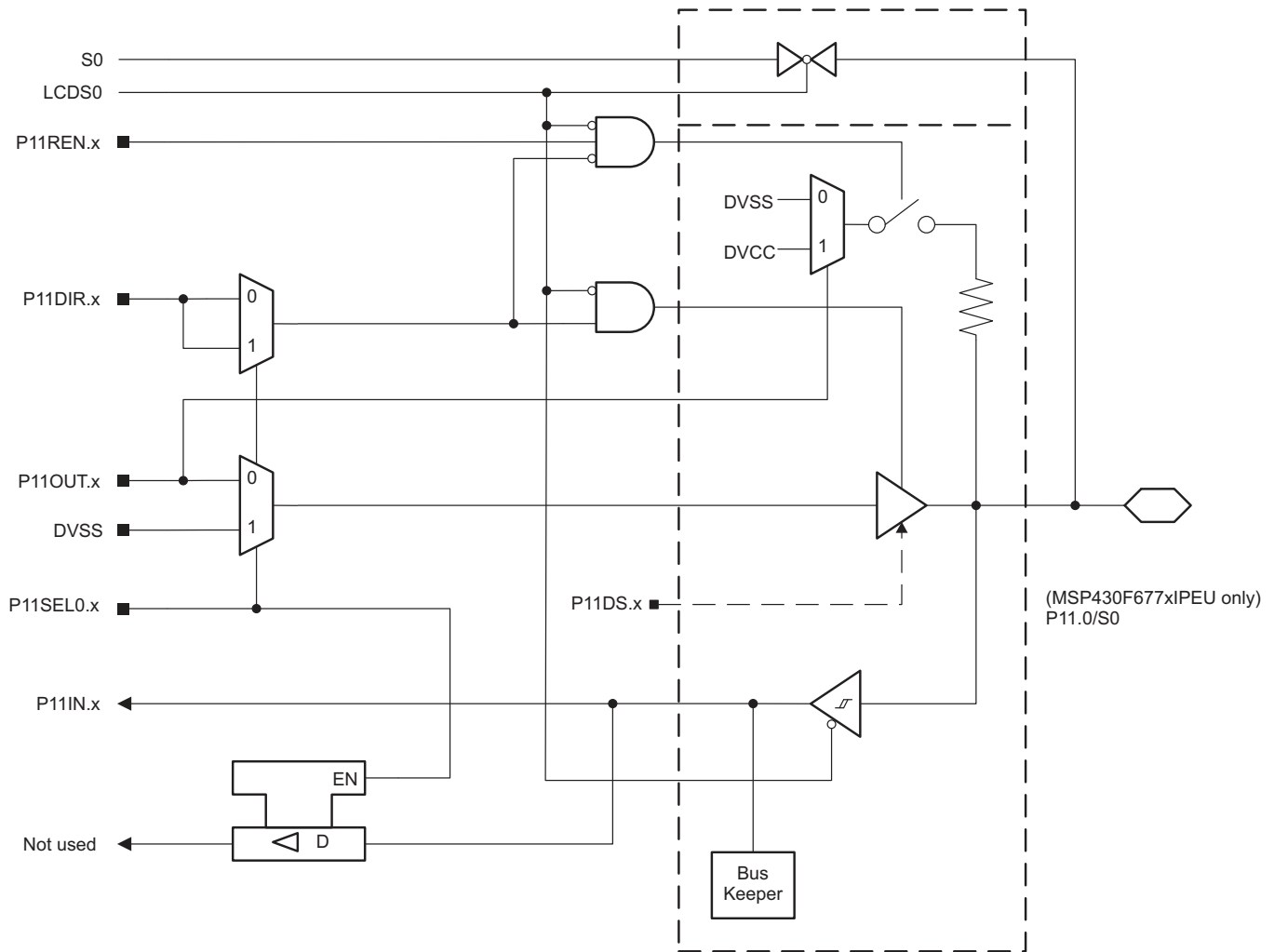

Figure 6-34. Port P11 (P11.0) Diagram (PEU Package Only)

Table 6-93. Port P11 (P11.0) Pin Functions (PEU Package Only)

PIN NAME (P11.x)	x	FUNCTION	CONTROL BITS OR SIGNALS ⁽¹⁾		
			P11DIR.x	P11SEL0.x	LCDS0
P11.0/S0	0	P11.0 (I/O)	I:0; O:1	0	0
		N/A	0	1	0
		DVSS	1	1	0
		S0	X	X	1

(1) X = don't care

6.12.30 Port P11 (P11.1) Input/Output With Schmitt Trigger (PEU Package Only)

Figure 6-35 shows the port diagram. Table 6-94 summarizes the selection of the pin functions.

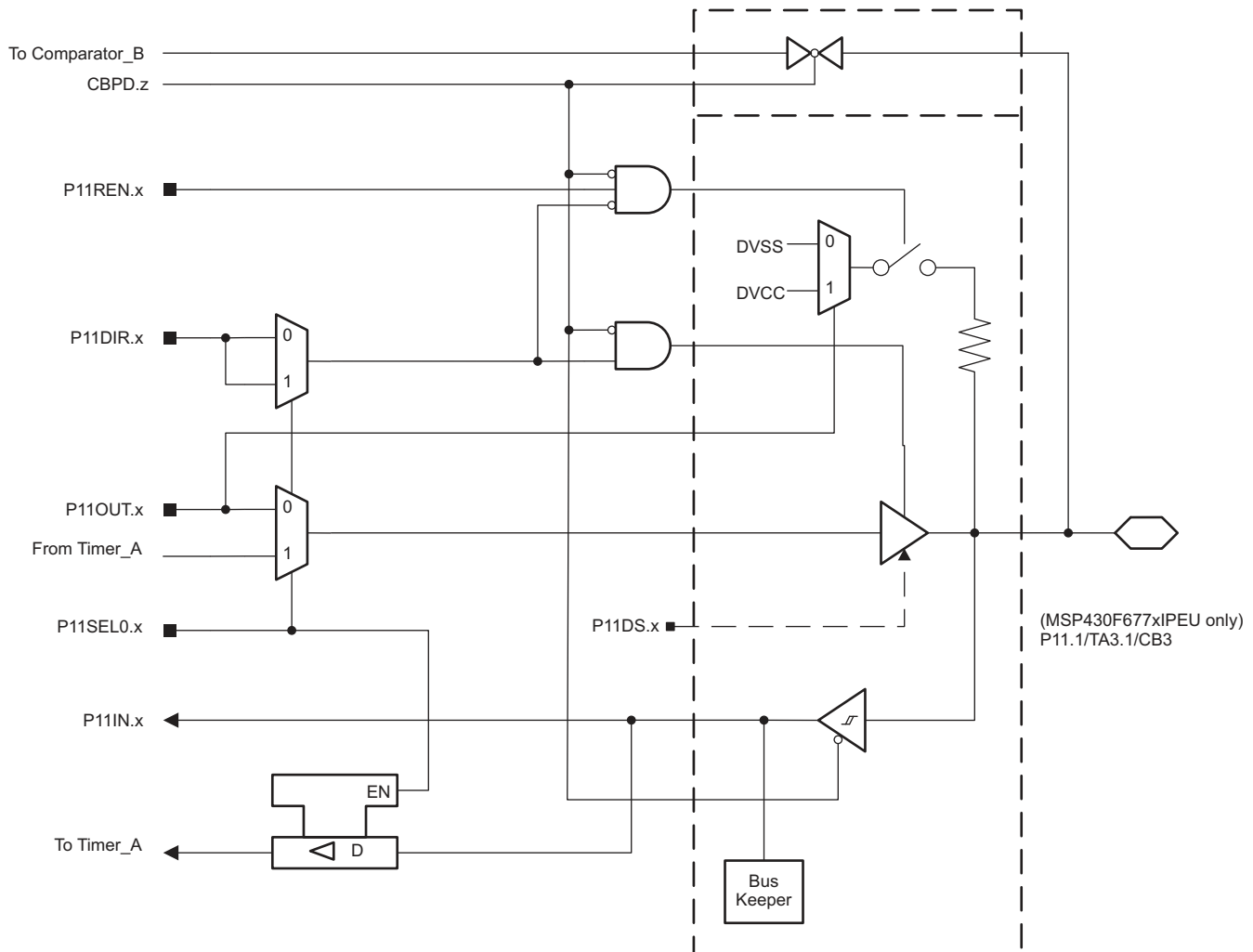

Figure 6-35. Port P11 (P11.1) Diagram (PEU Package Only)

Table 6-94. Port P11 (P11.1) Pin Functions (PEU Package Only)

PIN NAME (P11.x)	x	FUNCTION	CONTROL BITS OR SIGNALS ⁽¹⁾		
			P11DIR.x	P11SEL0.x	CBPD.z
P11.1/TA3.1/CB3	1	P11.1 (I/O)	I:0; O:1	0	0
		TA3.CCI1A	0	1	0
		TA3.1	1	1	0
		CB3	X	X	1

(1) X = don't care

6.12.31 Port P11 (P11.2 and P11.3) Input/Output With Schmitt Trigger (PEU Package Only)

Figure 6-36 shows the port diagram. Table 6-95 summarizes the selection of the pin functions.

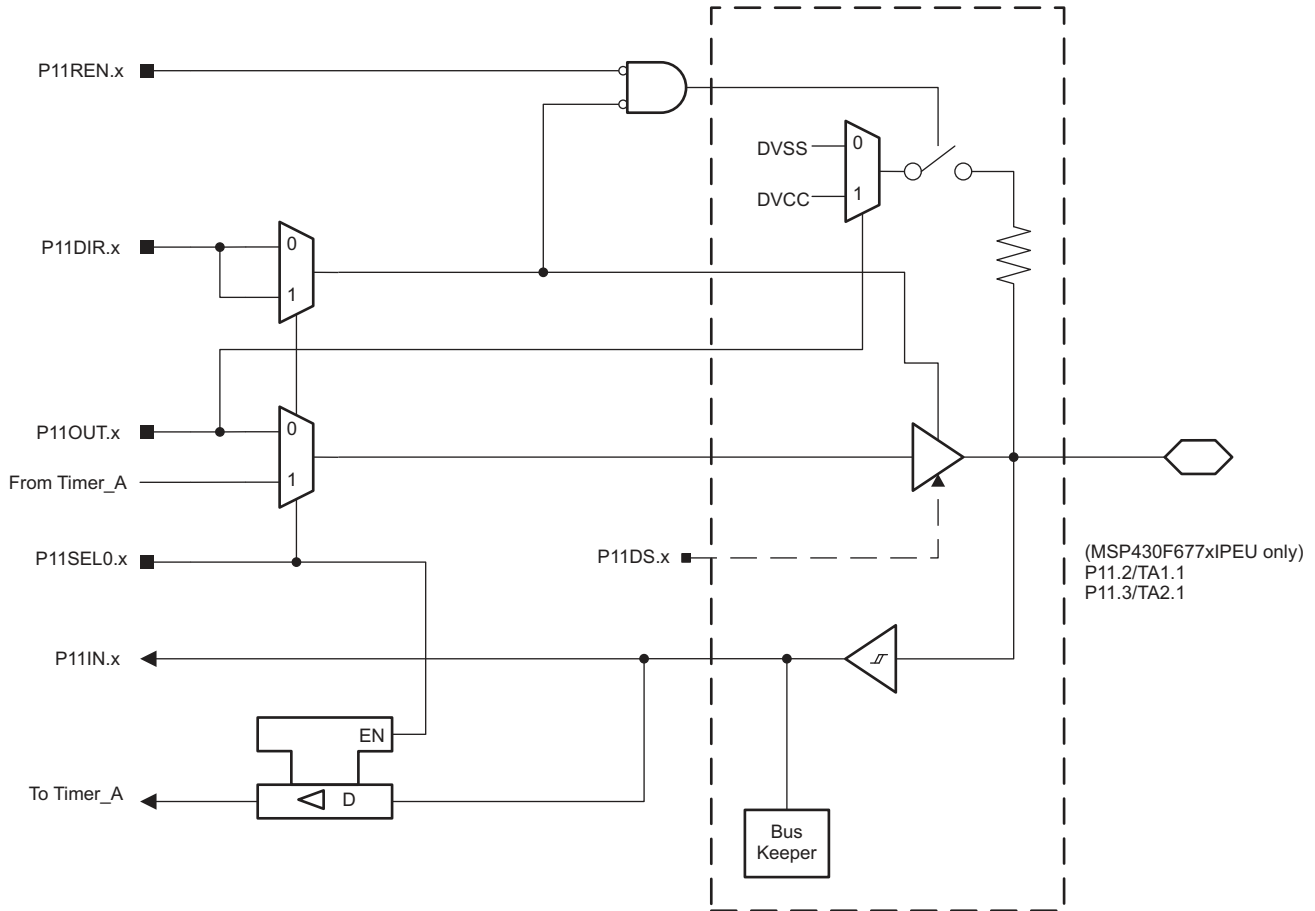

Figure 6-36. Port P11 (P11.2 and P11.3) Diagram (PEU Package Only)

Table 6-95. Port P11 (P11.2 and P11.3) Pin Functions (PEU Package Only)

PIN NAME (P11.x)	x	FUNCTION	CONTROL BITS OR SIGNALS	
			P11DIR.x	P11SEL0.x
P11.2/TA1.1	2	P11.2 (I/O)	I:0; O:1	0
		TA1.CCI1A	0	1
		TA1.1	1	1
P11.3/TA2.1	3	P11.3 (I/O)	I:0; O:1	0
		TA2.CCI1A	0	1
		TA2.1	1	1

6.12.32 Port P11 (P11.4 and P11.5) Input/Output With Schmitt Trigger (PEU Package Only)

Figure 6-37 shows the port diagram. Table 6-96 summarizes the selection of the pin functions.

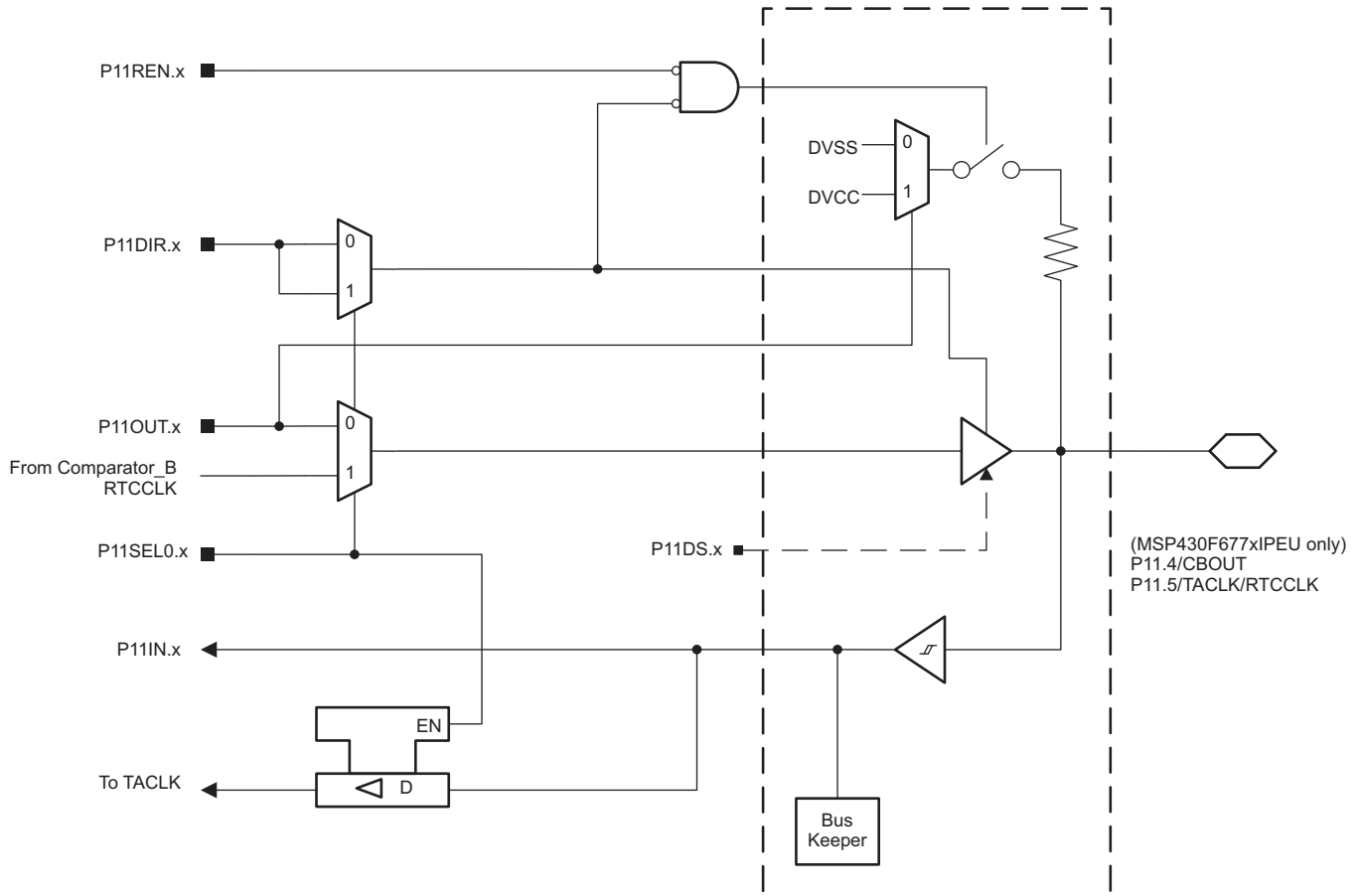

Figure 6-37. Port P11 (P11.4 and P11.5) Diagram (PEU Package Only)

Table 6-96. Port P11 (P11.4 and P11.5) Pin Functions (PEU Package Only)

PIN NAME (P11.x)	x	FUNCTION	CONTROL BITS OR SIGNALS	
			P11DIR.x	P11SEL0.x
P11.4/CBOUT	4	P11.4 (I/O)	I:0; O:1	0
		N/A	0	1
		CBOUT	1	1
P11.5/TACLK/RTCCLK	5	P11.5 (I/O)	I:0; O:1	0
		TACLK	0	1
		RTCCLK	1	1

6.12.33 Port PJ (PJ.0) JTAG Pin TDO, Input/Output With Schmitt Trigger or Output

Figure 6-38 shows the port diagram. Table 6-97 summarizes the selection of the pin functions.

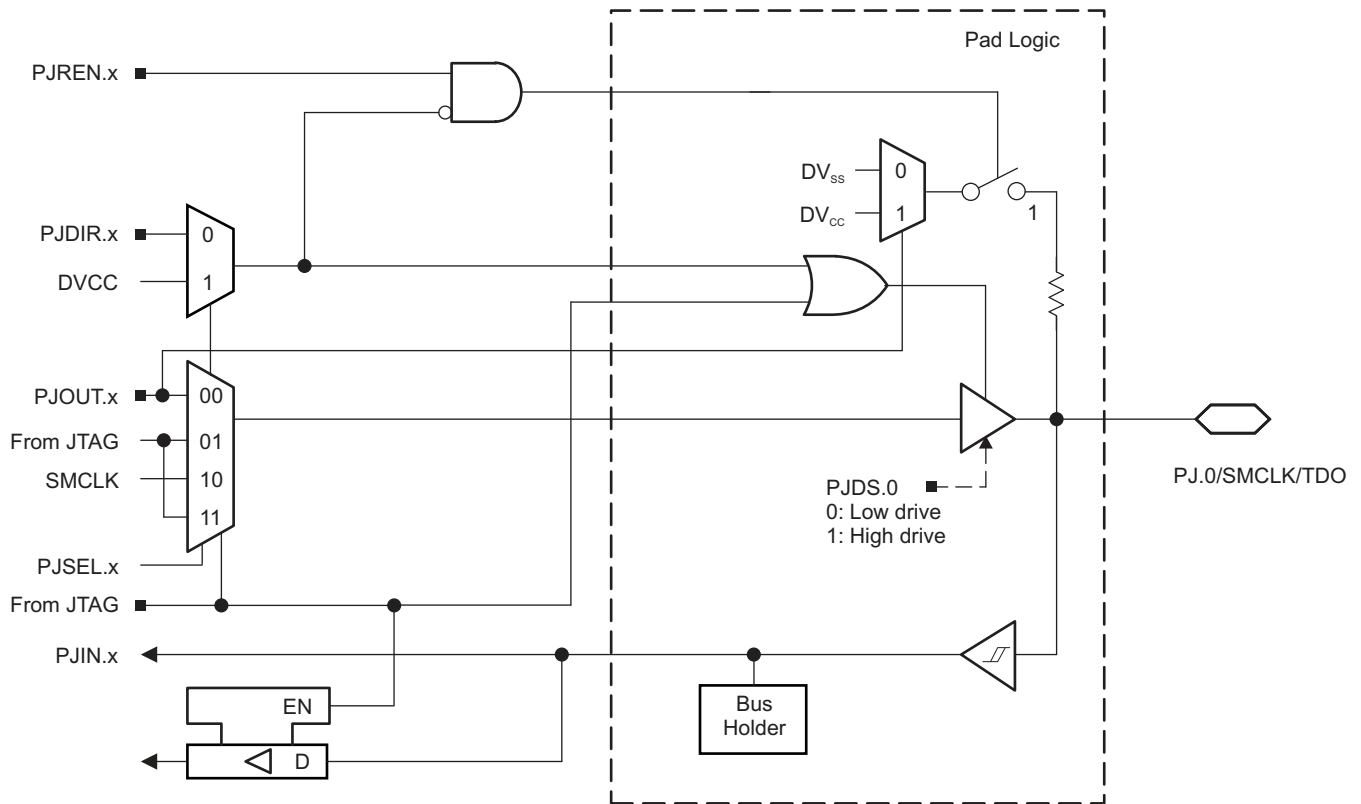

Figure 6-38. Port PJ (PJ.0) Diagram

6.12.34 Port PJ (PJ.0 to PJ.3) JTAG Pins TMS, TCK, TDI/TCLK, Input/Output With Schmitt Trigger or Output

Figure 6-39 shows the port diagram. Table 6-97 summarizes the selection of the pin functions.

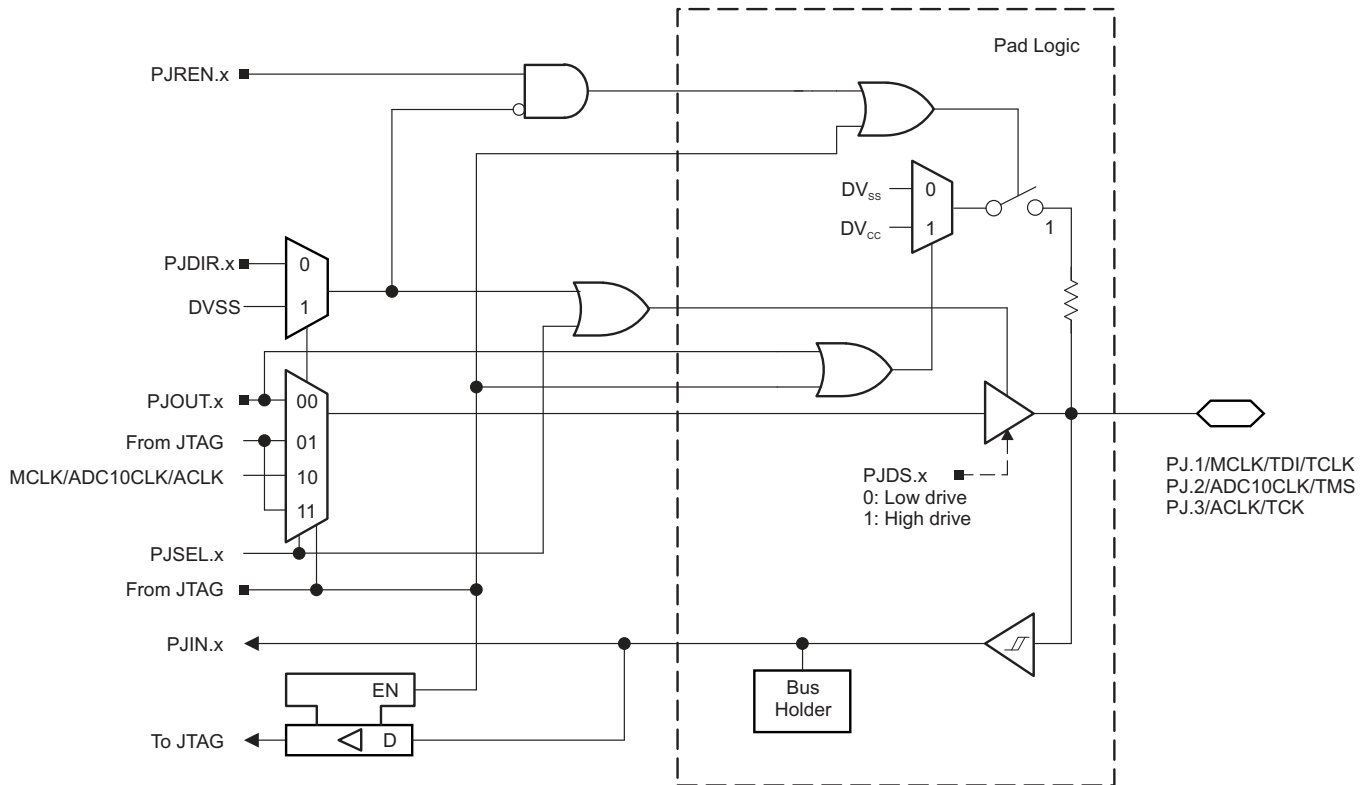

Figure 6-39. Port PJ (PJ.1 to PJ.3) Diagram

Table 6-97. Port PJ (PJ.0 to PJ.3) Pin Functions

PIN NAME (PJ.x)	x	FUNCTION	CONTROL BITS OR SIGNALS ⁽¹⁾		
			PJDIR.x	PJSEL.x	JTAG MODE
PJ.0/SMCLK/TDO	0	PJ.0 (I/O) ⁽²⁾	I: 0; O: 1	0	0
		SMCLK	1	1	0
		TDO ⁽³⁾	x	x	1
PJ.1/MCLK/TDI/TCLK	1	PJ.1 (I/O) ⁽²⁾	I: 0; O: 1	0	0
		MCLK	1	1	0
		TDI/TCLK ^{(3) (4)}	x	x	1
PJ.2/ADC10CLK/TMS	2	PJ.2 (I/O) ⁽²⁾	I: 0; O: 1	0	0
		ADC10CLK	1	1	0
		TMS ^{(3) (4)}	x	x	1
PJ.3/ACLK/TCK	3	PJ.3 (I/O) ⁽²⁾	I: 0; O: 1	0	0
		ACLK	1	1	0
		TCK ^{(3) (4)}	x	x	1

(1) X = don't care

(2) Default condition

(3) The pin direction is controlled by the JTAG module.

(4) In JTAG mode, pullups are activated automatically on TMS, TCK, and TDI/TCLK. PJREN.x are don't care.

6.13 Device Descriptors (TLV)

Table 6-98 through Table 6-100 list the contents of the device descriptor tag-length-value (TLV) structure for each device type.

Table 6-98. F677xA Device Descriptor

DESCRIPTION	ADDRESS	SIZE (bytes)	VALUE					
			F6779A	F6778A	F6777A	F6776A	F6775A	
Info Block	Info length	1A00h	1	06h	06h	06h	06h	06h
	CRC length	1A01h	1	06h	06h	06h	06h	06h
	CRC value	1A02h	2	Per unit	Per unit	Per unit	Per unit	Per unit
	Device ID	1A04h	2	8224h	8223h	8222h	8221h	8220h
	Hardware revision	1A06h	1	Per unit	Per unit	Per unit	Per unit	Per unit
	Firmware revision	1A07h	1	Per unit	Per unit	Per unit	Per unit	Per unit
Die Record	Die record tag	1A08h	1	08h	08h	08h	08h	08h
	Die record length	1A09h	1	0Ah	0Ah	0Ah	0Ah	0Ah
	Lot ID	1A0Ah	4	Per unit	Per unit	Per unit	Per unit	Per unit
	X position	1A0Eh	2	Per unit	Per unit	Per unit	Per unit	Per unit
	Y position	1A10h	2	Per unit	Per unit	Per unit	Per unit	Per unit
	Test record CP	1A12h	1	Per unit	Per unit	Per unit	Per unit	Per unit
	Test record FT	1A13h	1	Per unit	Per unit	Per unit	Per unit	Per unit
ADC10 Calibration	ADC calibration tag	1A14h	1	13h	13h	13h	13h	13h
	ADC calibration length	1A15h	1	10h	10h	10h	10h	10h
	ADC gain factor	1A16h	2	Per unit	Per unit	Per unit	Per unit	Per unit
	ADC offset	1A18h	2	Per unit	Per unit	Per unit	Per unit	Per unit
	ADC 15T30	1A1Ah	2	Per unit	Per unit	Per unit	Per unit	Per unit
	ADC 15T85	1A1Ch	2	Per unit	Per unit	Per unit	Per unit	Per unit
	ADC 20T30	1A1Eh	2	Per unit	Per unit	Per unit	Per unit	Per unit
	ADC 20T85	1A20h	2	Per unit	Per unit	Per unit	Per unit	Per unit
	ADC 25T30	1A22h	2	Per unit	Per unit	Per unit	Per unit	Per unit
ADC 25T85	1A24h	2	Per unit	Per unit	Per unit	Per unit	Per unit	

Table 6-99. F676xA Device Descriptor

DESCRIPTION		ADDRESS	SIZE (bytes)	VALUE				
				F6769A	F6768A	F6767A	F6766A	F6765A
Info Block	Info length	1A00h	1	06h	06h	06h	06h	06h
	CRC length	1A01h	1	06h	06h	06h	06h	06h
	CRC value	1A02h	2	Per unit	Per unit	Per unit	Per unit	Per unit
	Device ID	1A04h	2	821Fh	821Eh	821Dh	821Ch	821Bh
	Hardware revision	1A06h	1	Per unit	Per unit	Per unit	Per unit	Per unit
	Firmware revision	1A07h	1	Per unit	Per unit	Per unit	Per unit	Per unit
Die Record	Die record tag	1A08h	1	08h	08h	08h	08h	08h
	Die record length	1A09h	1	0Ah	0Ah	0Ah	0Ah	0Ah
	Lot ID	1A0Ah	4	Per unit	Per unit	Per unit	Per unit	Per unit
	X position	1A0Eh	2	Per unit	Per unit	Per unit	Per unit	Per unit
	Y position	1A10h	2	Per unit	Per unit	Per unit	Per unit	Per unit
	Test record CP	1A12h	1	Per unit	Per unit	Per unit	Per unit	Per unit
	Test record FT	1A13h	1	Per unit	Per unit	Per unit	Per unit	Per unit
ADC10 Calibration	ADC calibration tag	1A14h	1	13h	13h	13h	13h	13h
	ADC calibration length	1A15h	1	10h	10h	10h	10h	10h
	ADC gain factor	1A16h	2	Per unit	Per unit	Per unit	Per unit	Per unit
	ADC offset	1A18h	2	Per unit	Per unit	Per unit	Per unit	Per unit
	ADC 15T30	1A1Ah	2	Per unit	Per unit	Per unit	Per unit	Per unit
	ADC 15T85	1A1Ch	2	Per unit	Per unit	Per unit	Per unit	Per unit
	ADC 20T30	1A1Eh	2	Per unit	Per unit	Per unit	Per unit	Per unit
	ADC 20T85	1A20h	2	Per unit	Per unit	Per unit	Per unit	Per unit
	ADC 25T30	1A22h	2	Per unit	Per unit	Per unit	Per unit	Per unit
ADC 25T85	1A24h	2	Per unit	Per unit	Per unit	Per unit	Per unit	

Table 6-100. F674xA Device Descriptor

DESCRIPTION		ADDRESS	SIZE (bytes)	VALUE				
				F6749A	F6748A	F6747A	F6746A	F6745A
Info Block	Info length	1A00h	1	06h	06h	06h	06h	06h
	CRC length	1A01h	1	06h	06h	06h	06h	06h
	CRC value	1A02h	2	Per unit	Per unit	Per unit	Per unit	Per unit
	Device ID	1A04h	2	821Ah	8219h	8218h	8217h	8216h
	Hardware revision	1A06h	1	Per unit	Per unit	Per unit	Per unit	Per unit
	Firmware revision	1A07h	1	Per unit	Per unit	Per unit	Per unit	Per unit
Die Record	Die record tag	1A08h	1	08h	08h	08h	08h	08h
	Die record length	1A09h	1	0Ah	0Ah	0Ah	0Ah	0Ah
	Lot ID	1A0Ah	4	Per unit	Per unit	Per unit	Per unit	Per unit
	X position	1A0Eh	2	Per unit	Per unit	Per unit	Per unit	Per unit
	Y position	1A10h	2	Per unit	Per unit	Per unit	Per unit	Per unit
	Test record CP	1A12h	1	Per unit	Per unit	Per unit	Per unit	Per unit
	Test record FT	1A13h	1	Per unit	Per unit	Per unit	Per unit	Per unit
ADC10 Calibration	ADC calibration tag	1A14h	1	13h	13h	13h	13h	13h
	ADC calibration length	1A15h	1	10h	10h	10h	10h	10h
	ADC gain factor	1A16h	2	Per unit	Per unit	Per unit	Per unit	Per unit
	ADC offset	1A18h	2	Per unit	Per unit	Per unit	Per unit	Per unit
	ADC 15T30	1A1Ah	2	Per unit	Per unit	Per unit	Per unit	Per unit
	ADC 15T85	1A1Ch	2	Per unit	Per unit	Per unit	Per unit	Per unit
	ADC 20T30	1A1Eh	2	Per unit	Per unit	Per unit	Per unit	Per unit
	ADC 20T85	1A20h	2	Per unit	Per unit	Per unit	Per unit	Per unit
	ADC 25T30	1A22h	2	Per unit	Per unit	Per unit	Per unit	Per unit
ADC 25T85	1A24h	2	Per unit	Per unit	Per unit	Per unit	Per unit	

6.14 Identification

6.14.1 Revision Identification

The device revision information is shown as part of the top-side marking on the device package. The device-specific errata sheet describes these markings. For links to all of the errata sheets for the devices in this data sheet, see [Section 8.4](#).

The hardware revision is also stored in the Device Descriptor structure in the Info Block section. For details on this value, see the "Hardware Revision" entries in [Section 6.13](#).

6.14.2 Device Identification

The device type can be identified from the top-side marking on the device package. The device-specific errata sheet describes these markings. For links to all of the errata sheets for the devices in this data sheet, see [Section 8.4](#).

A device identification value is also stored in the Device Descriptor structure in the Info Block section. For details on this value, see the "Device ID" entries in [Section 6.13](#).

6.14.3 JTAG Identification

Programming through the JTAG interface, including reading and identifying the JTAG ID, is described in detail in the [MSP430 Programming With the JTAG Interface](#).

7 Applications, Implementation, and Layout

NOTE

Information in the following Applications section is not part of the TI component specification, and TI does not warrant its accuracy or completeness. TI's customers are responsible for determining suitability of components for their purposes. Customers should validate and test their design implementation to confirm system functionality.

The following resources provide application guidelines and best practices when designing with the MSP430F677xA, MSP430F676xA, and MSP430F674xA devices.

Implementation of a 3-Phase Electronic Watt-Hour Meter Using the MSP430F677x(A)

This application report describes the implementation of a 3-phase electronic electricity meter using the TI MSP430F677x(A) metering processors. This application report includes the necessary information with regard to metrology software and hardware procedures for this single-chip implementation.

High-Accuracy 3-Phase Electricity Meter With Tamper Detection

The design implements a highly accurate 3-phase electric meter system using the MSP430F6779 smart meter SoC. It exceeds all of the requirements for ANSI C12.20 and IEC-62053 Class 0.2 meters. The F6779 SoC is the most integrated polyphase e-meter SoC with 512KB of flash. This allows developers to create a true single-chip smart e-meter with the highest performance and accuracy. In addition, this EVM has tamper detection capabilities which help the engineer develop methods to prevent theft of electricity from utilities.

Features

- Comprehensive design includes schematics, BOMs, design files, and test reports.
- Three-phase electricity meter which exceeds Class 0.2 accuracy requirements from ANSI and IEC
- TI Energy Library firmware calculates all energy measurement parameters including active and reactive power and energy, RMS current and voltage, power factor, and line frequency.
- Add-on communications modules for wireless communications standards such as ZigBee®, Wi-Fi®, Wireless M-Bus, and IEEE Std 802.15.4g, both 2.4 GHz and sub-1 GHz
- Built-in 160-segment display powered from 3-phase line voltage

8 Device and Documentation Support

8.1 Getting Started and Next Steps

For more information on the MSP430™ family of devices and the tools and libraries that are available to help with your development, visit the [Getting Started](#) page.

8.2 Device Nomenclature

To designate the stages in the product development cycle, TI assigns prefixes to the part numbers of all MSP MCU devices. Each MSP MCU commercial family member has one of two prefixes: MSP or XMS. These prefixes represent evolutionary stages of product development from engineering prototypes (XMS) through fully qualified production devices (MSP).

XMS – Experimental device that is not necessarily representative of the final device's electrical specifications

MSP – Fully qualified production device

XMS devices are shipped against the following disclaimer:

"Developmental product is intended for internal evaluation purposes."

MSP devices have been characterized fully, and the quality and reliability of the device have been demonstrated fully. TI's standard warranty applies.

Predictions show that prototype devices (XMS) have a greater failure rate than the standard production devices. TI recommends that these devices not be used in any production system because their expected end-use failure rate still is undefined. Only qualified production devices are to be used.

TI device nomenclature also includes a suffix with the device family name. This suffix indicates the temperature range, package type, and distribution format. [Figure 8-1](#) provides a legend for reading the complete device name.

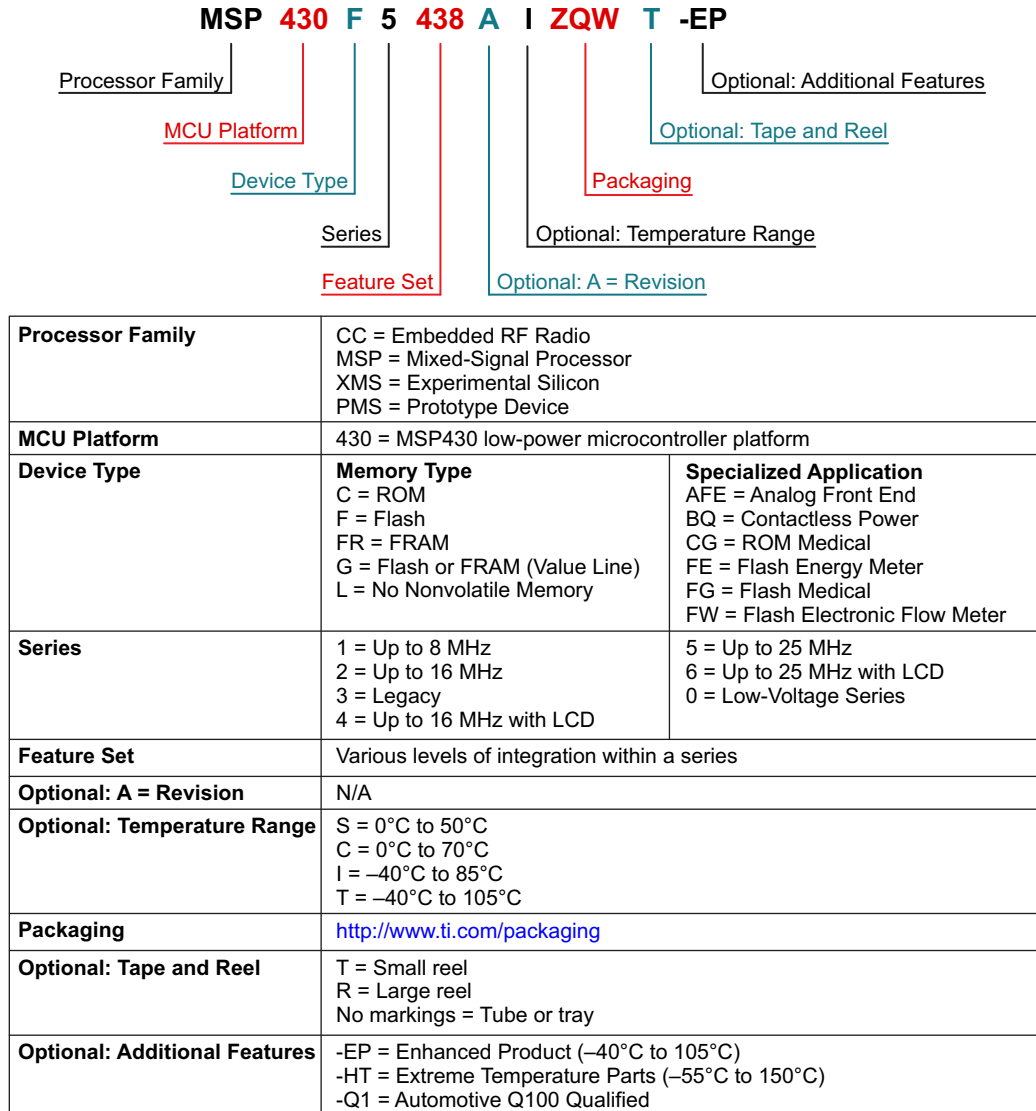

Figure 8-1. Device Nomenclature

8.3 Tools and Software

All MSP microcontrollers are supported by a wide variety of software and hardware development tools. Tools are available from TI and various third parties. See them all at [MSP430 Ultra-Low-Power MCUs – Tools & software](#).

Table 8-1 lists the debug features of the MSP430F677xA, MSP430F676xA, and MSP430F674xA MCUs. See the [Code Composer Studio for MSP430 User's Guide](#) for details on the available features.

Table 8-1. Hardware Debug Features

MSP430 ARCHITECTURE	4-WIRE JTAG	2-WIRE JTAG	BREAK-POINTS (N)	RANGE BREAK-POINTS	CLOCK CONTROL	STATE SEQUENCER	TRACE BUFFER	LPMx.5 DEBUGGING SUPPORT
MSP430Xv2	Yes	Yes	3	Yes	Yes	No	No	Yes

Design Kits and Evaluation Modules

3-Phase Electronic Watt-Hour EVM for Metering (EVM430-F6779) This EVM430-F6779 is a three-phase electricity meter evaluation module based on the MSP430F6779A device. The E-meter has inputs for three voltages and three currents, as well as an additional connection to demonstrate antitampering. The EVM lets you test the new F677x, F674x, F676x, F677x1, F674x1, F676x1 series and see the accuracy results, wide dynamic range achieved, and ease of calibration. The easy-to-use Energy Library provides metrology software for fast startup with this EVM. The software is also programmable for any user's needs.

Three-Phase Metrology With Enhanced ESD Protection and Tamper Detection Reference Design

This design implements an ANSI/IEC Class 0.2 three-phase energy meter with enhanced ESD protection. The design also features tamper detection to limit the feasibility of energy theft and communications through ZigBee connectivity. The e-meter SoC is used to perform all metrology functions and sends active power results to the CC2530EM add-on board. Developers can use the companion In Home Display TI Design (TIDM-LOWEND-IHD) to display results remotely.

128-Pin Target Development Board and MSP-FET Programmer Bundle for MSP430F6x MCUs The MSP-FET430U128 is a powerful flash emulation tool to quickly begin application development on the MSP430 MCU. It includes a USB debugging interface used to program and debug the MSP430 in system through the JTAG interface or the pin-saving Spy-Bi-Wire (2-wire JTAG) protocol.

Software

MSP430Ware™ Software MSP430Ware software is a collection of code examples, data sheets, and other design resources for all MSP430 devices delivered in a convenient package. In addition to providing a complete collection of existing MSP430 design resources, MSP430Ware software also includes a high-level API called MSP Driver Library. This library makes it easy to program MSP430 hardware. MSP430Ware software is available as a component of CCS or as a stand-alone package.

Energy Measurement Design Center for MSP430 MCUs The Energy Measurement Design Center is a rapid development tool that enables energy measurement using TI MSP430i20xx and MSP430F67xx flash-based microcontrollers (MCUs). It includes a graphical user interface (GUI), documentation, software library, and examples that can simplify development and accelerate designs in a wide range of power monitoring and energy measurement applications, including smart grid and building automation. Using the Design Center, you can configure, calibrate, and view results without writing a single line of code.

MSP Driver Library The abstracted API of MSP Driver Library provides easy-to-use function calls that free you from directly manipulating the bits and bytes of the MSP430 hardware. Thorough documentation is delivered through a helpful API Guide, which includes details on each function call and the recognized parameters. Developers can use Driver Library functions to write complete projects with minimal overhead.

MSP430F677x(1)A, MSP430F676x(1)A, MSP430F674x(1)A Code Examples C code examples that configure each of the integrated peripherals for various application needs are available for every MSP device.

MSP EnergyTrace™ Technology EnergyTrace technology for MSP430 microcontrollers is an energy-based code analysis tool that measures and displays the energy profile of the application and helps to optimize it for ultra-low-power consumption.

ULP (Ultra-Low Power) Advisor ULP Advisor™ software is a tool for guiding developers to write more efficient code to fully use the unique ultra-low-power features of MSP and MSP432 microcontrollers. Aimed at both experienced and new microcontroller developers, ULP Advisor checks your code against a thorough ULP checklist to help minimize the energy consumption of your application. At build time, ULP Advisor provides notifications and remarks to highlight areas of your code that can be further optimized for lower power.

Fixed Point Math Library for MSP The MSP IQmath and Qmath Libraries are a collection of highly optimized and high-precision mathematical functions for C programmers to seamlessly port a floating-point algorithm into fixed-point code on MSP430 and MSP432 devices. These routines are typically used in computationally intensive real-time applications where optimal execution speed, high accuracy, and ultra-low energy are critical. By using the IQmath and Qmath libraries, it is possible to achieve execution speeds considerably faster and energy consumption considerably lower than equivalent code written using floating-point math.

Floating Point Math Library for MSP430 Continuing to innovate in the low-power and low-cost microcontroller space, TI provides MSPMATHLIB. Leveraging the intelligent peripherals of our devices, this floating-point math library of scalar functions that are up to 26 times faster than the standard MSP430 math functions. Mathlib is easy to integrate into your designs. This library is free and is integrated in both Code Composer Studio IDE and IAR Embedded Workbench IDE.

Development Tools

Code Composer Studio™ Integrated Development Environment for MSP Microcontrollers Code Composer Studio (CCS) integrated development environment (IDE) supports all MSP microcontroller devices. CCS comprises a suite of embedded software utilities used to develop and debug embedded applications. It includes an optimizing C/C++ compiler, source code editor, project build environment, debugger, profiler, and many other features.

Command-Line Programmer MSP Flasher is an open-source shell-based interface for programming MSP microcontrollers through a FET programmer or eZ430 using JTAG or Spy-Bi-Wire (SBW) communication. MSP Flasher can download binary files (.txt or .hex) directly to the MSP microcontroller without an IDE.

MSP MCU Programmer and Debugger The MSP-FET is a powerful emulation development tool – often called a debug probe – which lets users quickly begin application development on MSP low-power MCUs. Creating MCU software usually requires downloading the resulting binary program to the MSP device for validation and debugging.

MSP-GANG Production Programmer The MSP Gang Programmer is an MSP430 or MSP432 device programmer that can program up to eight identical MSP430 or MSP432 flash or FRAM devices at the same time. The MSP Gang Programmer connects to a host PC using a standard RS-232 or USB connection and provides flexible programming options that let the user fully customize the process.

8.4 Documentation Support

The following documents describe the MSP430F677xA, MSP430F676xA, and MSP430F674xA MCUs. Copies of these documents are available on the Internet at www.ti.com.

Receiving Notification of Document Updates

To receive notification of documentation updates—including silicon errata—go to the product folder for your device on ti.com (for links to the product folders, see [Section 8.5](#)). In the upper right corner, click the "Alert me" button. This registers you to receive a weekly digest of product information that has changed (if any). For change details, check the revision history of any revised document.

Errata

- [MSP430F6779A Device Erratasheet](#)** Describes the known exceptions to the functional specifications.
- [MSP430F6778A Device Erratasheet](#)** Describes the known exceptions to the functional specifications.
- [MSP430F6777A Device Erratasheet](#)** Describes the known exceptions to the functional specifications.
- [MSP430F6776A Device Erratasheet](#)** Describes the known exceptions to the functional specifications.
- [MSP430F6775A Device Erratasheet](#)** Describes the known exceptions to the functional specifications.
- [MSP430F6769A Device Erratasheet](#)** Describes the known exceptions to the functional specifications.
- [MSP430F6768A Device Erratasheet](#)** Describes the known exceptions to the functional specifications.
- [MSP430F6767A Device Erratasheet](#)** Describes the known exceptions to the functional specifications.
- [MSP430F6766A Device Erratasheet](#)** Describes the known exceptions to the functional specifications.
- [MSP430F6765A Device Erratasheet](#)** Describes the known exceptions to the functional specifications.
- [MSP430F6749A Device Erratasheet](#)** Describes the known exceptions to the functional specifications.
- [MSP430F6748A Device Erratasheet](#)** Describes the known exceptions to the functional specifications.
- [MSP430F6747A Device Erratasheet](#)** Describes the known exceptions to the functional specifications.
- [MSP430F6746A Device Erratasheet](#)** Describes the known exceptions to the functional specifications.
- [MSP430F6745A Device Erratasheet](#)** Describes the known exceptions to the functional specifications.

User's Guides

- [MSP430x5xx and MSP430x6xx Family User's Guide](#)** Detailed information on the modules and peripherals available in this device family.
- [MSP430™ Flash Device Bootloader \(BSL\) User's Guide](#)** The MSP430 bootloader (BSL) lets users communicate with embedded memory in the MSP430 microcontroller during the prototyping phase, final production, and in service. Both the programmable memory (flash memory) and the data memory (RAM) can be modified as required. Do not confuse the bootloader with the bootstrap loader programs found in some digital signal processors (DSPs) that automatically load program code (and data) from external memory to the internal memory of the DSP.
- [MSP430 Programming With the JTAG Interface](#)** This document describes the functions that are required to erase, program, and verify the memory module of the MSP430 flash-based and FRAM-based microcontroller families using the JTAG communication port. In addition, it describes how to program the JTAG access security fuse that is available on all MSP430 devices. This document describes device access using both the standard 4-wire JTAG interface and the 2-wire JTAG interface, which is also referred to as Spy-Bi-Wire (SBW).
- [MSP430 Hardware Tools User's Guide](#)** This manual describes the hardware of the TI MSP-FET430 Flash Emulation Tool (FET). The FET is the program development tool for the MSP430 ultra-low-power microcontroller. Both available interface types, the parallel port interface and the USB interface, are described.

Application Reports

- Implementation of a Three-Phase Electronic Watt-Hour Meter Using MSP430F677x(A)** This application report describes the implementation of a three-phase electronic electricity meter using the MSP430F677x(A) metering processor. This application report includes the necessary information with regard to metrology software, hardware procedures for this single-chip implementation.
- Using TI's DLMS COSEM Library** This application report describes in detail the usage of DLMS COSEM library developed by Texas Instruments for customers who use TI's microcontrollers in metering applications. The library is provided as object code with a configuration file for ease of use. The library can be obtained by contacting the regional sales and marketing offices.
- Differences Between MSP430F67xx and MSP430F67xxA Devices** This application report describes the enhancements of the MSP430F67xxA devices from the non-A MSP430F67xx devices. This application report describes the MSP430F67xx errata that are fixed in the MSP430F67xxA and the additional features added to the MSP430F67xxA devices. In addition, metrology results are compared to further show that the changes implemented in the MSP430F67xxA devices do not affect the metrology performance.
- MSP430 32-kHz Crystal Oscillators** Selection of the correct crystal, correct load circuit, and proper board layout are important for a stable crystal oscillator. This application report summarizes crystal oscillator function and explains the parameters to select the correct crystal for MSP430 ultra-low-power operation. In addition, hints and examples for correct board layout are given. The document also contains detailed information on the possible oscillator tests to ensure stable oscillator operation in mass production.
- MSP430 System-Level ESD Considerations** System-Level ESD has become increasingly demanding with silicon technology scaling towards lower voltages and the need for designing cost-effective and ultra-low-power components. This application report addresses three different ESD topics to help board designers and OEMs understand and design robust system-level designs.
- Designing With MSP430 and Segment LCDs** Segment liquid crystal displays (LCDs) are needed to provide information to users in a wide variety of applications from smart meters to electronic shelf labels (ESLs) to medical equipment. Several MSP430™ microcontroller families include built-in low-power LCD driver circuitry that allows the MSP430 MCU to directly control the segmented LCD glass. This application note helps explain how segmented LCDs work, the different features of the various LCD modules across the MSP430 MCU family, LCD hardware layout tips, guidance on writing efficient and easy-to-use LCD driver software, and an overview of the portfolio of MSP430 devices that include different LCD features to aid in device selection.

8.5 Related Links

Table 8-2 lists quick access links. Categories include technical documents, support and community resources, tools and software, and quick access to sample or buy.

Table 8-2. Related Links

PARTS	PRODUCT FOLDER	ORDER NOW	TECHNICAL DOCUMENTS	TOOLS & SOFTWARE	SUPPORT & COMMUNITY
MSP430F6779A	Click here	Click here	Click here	Click here	Click here
MSP430F6778A	Click here	Click here	Click here	Click here	Click here
MSP430F6777A	Click here	Click here	Click here	Click here	Click here
MSP430F6776A	Click here	Click here	Click here	Click here	Click here
MSP430F6775A	Click here	Click here	Click here	Click here	Click here
MSP430F6769A	Click here	Click here	Click here	Click here	Click here
MSP430F6768A	Click here	Click here	Click here	Click here	Click here
MSP430F6767A	Click here	Click here	Click here	Click here	Click here
MSP430F6766A	Click here	Click here	Click here	Click here	Click here
MSP430F6765A	Click here	Click here	Click here	Click here	Click here
MSP430F6749A	Click here	Click here	Click here	Click here	Click here
MSP430F6748A	Click here	Click here	Click here	Click here	Click here
MSP430F6747A	Click here	Click here	Click here	Click here	Click here
MSP430F6746A	Click here	Click here	Click here	Click here	Click here
MSP430F6745A	Click here	Click here	Click here	Click here	Click here

8.6 Community Resources

The following links connect to TI community resources. Linked contents are provided "AS IS" by the respective contributors. They do not constitute TI specifications and do not necessarily reflect TI's views; see TI's [Terms of Use](#).

[TI E2E™ Community](#)

TI's Engineer-to-Engineer (E2E) Community. Created to foster collaboration among engineers. At e2e.ti.com, you can ask questions, share knowledge, explore ideas, and help solve problems with fellow engineers.

[TI Embedded Processors Wiki](#)

Texas Instruments Embedded Processors Wiki. Established to help developers get started with embedded processors from Texas Instruments and to foster innovation and growth of general knowledge about the hardware and software surrounding these devices.

8.7 Trademarks

MSP430, MSP430Ware, EnergyTrace, ULP Advisor, Code Composer Studio, E2E are trademarks of Texas Instruments.

Wi-Fi is a registered trademark of Wi-Fi Alliance.

ZigBee is a registered trademark of ZigBee Alliance.

8.8 Electrostatic Discharge Caution

This integrated circuit can be damaged by ESD. Texas Instruments recommends that all integrated circuits be handled with appropriate precautions. Failure to observe proper handling and installation procedures can cause damage.



ESD damage can range from subtle performance degradation to complete device failure. Precision integrated circuits may be more susceptible to damage because very small parametric changes could cause the device not to meet its published specifications.

8.9 Glossary

[TI Glossary](#) This glossary lists and explains terms, acronyms, and definitions.

9 Mechanical, Packaging, and Orderable Information

The following pages include mechanical, packaging, and orderable information. This information is the most current data available for the designated devices. This data is subject to change without notice and revision of this document. For browser-based versions of this data sheet, refer to the left-hand navigation.

PACKAGING INFORMATION

Orderable Device	Status (1)	Package Type	Package Drawing	Pins	Package Qty	Eco Plan (2)	Lead finish/ Ball material (6)	MSL Peak Temp (3)	Op Temp (°C)	Device Marking (4/5)	Samples
MSP430F6745AIP EU	ACTIVE	LQFP	PEU	128	72	RoHS & Green	NIPDAU	Level-3-260C-168 HR	-40 to 85	F6745A	Samples
MSP430F6745AIP EUR	ACTIVE	LQFP	PEU	128	750	RoHS & Green	NIPDAU	Level-3-260C-168 HR	-40 to 85	F6745A	Samples
MSP430F6745AIP Z	ACTIVE	LQFP	PZ	100	90	RoHS & Green	NIPDAU	Level-3-260C-168 HR	-40 to 85	F6745A	Samples
MSP430F6745AIP ZR	ACTIVE	LQFP	PZ	100	1000	RoHS & Green	NIPDAU	Level-3-260C-168 HR	-40 to 85	F6745A	Samples
MSP430F6746AIP EU	ACTIVE	LQFP	PEU	128	72	RoHS & Green	NIPDAU	Level-3-260C-168 HR	-40 to 85	F6746A	Samples
MSP430F6746AIP EUR	ACTIVE	LQFP	PEU	128	750	RoHS & Green	NIPDAU	Level-3-260C-168 HR	-40 to 85	F6746A	Samples
MSP430F6746AIP Z	ACTIVE	LQFP	PZ	100	90	RoHS & Green	NIPDAU	Level-3-260C-168 HR	-40 to 85	F6746A	Samples
MSP430F6746AIP ZR	ACTIVE	LQFP	PZ	100	1000	RoHS & Green	NIPDAU	Level-3-260C-168 HR	-40 to 85	F6746A	Samples
MSP430F6747AIP EU	ACTIVE	LQFP	PEU	128	72	RoHS & Green	NIPDAU	Level-3-260C-168 HR	-40 to 85	F6747A	Samples
MSP430F6747AIP EUR	ACTIVE	LQFP	PEU	128	750	RoHS & Green	NIPDAU	Level-3-260C-168 HR	-40 to 85	F6747A	Samples
MSP430F6747AIP Z	ACTIVE	LQFP	PZ	100	90	RoHS & Green	NIPDAU	Level-3-260C-168 HR	-40 to 85	F6747A	Samples
MSP430F6747AIP ZR	ACTIVE	LQFP	PZ	100	1000	RoHS & Green	NIPDAU	Level-3-260C-168 HR	-40 to 85	F6747A	Samples
MSP430F6748AIP EU	ACTIVE	LQFP	PEU	128	72	RoHS & Green	NIPDAU	Level-3-260C-168 HR	-40 to 85	F6748A	Samples
MSP430F6748AIP EUR	ACTIVE	LQFP	PEU	128	750	RoHS & Green	NIPDAU	Level-3-260C-168 HR	-40 to 85	F6748A	Samples
MSP430F6748AIP Z	ACTIVE	LQFP	PZ	100	90	RoHS & Green	NIPDAU	Level-3-260C-168 HR	-40 to 85	F6748A	Samples
MSP430F6748AIP ZR	ACTIVE	LQFP	PZ	100	1000	RoHS & Green	NIPDAU	Level-3-260C-168 HR	-40 to 85	F6748A	Samples
MSP430F6749AIP EU	ACTIVE	LQFP	PEU	128	72	RoHS & Green	NIPDAU	Level-3-260C-168 HR	-40 to 85	F6749A	Samples
MSP430F6749AIP EUR	ACTIVE	LQFP	PEU	128	750	RoHS & Green	NIPDAU	Level-3-260C-168 HR	-40 to 85	F6749A	Samples
MSP430F6749AIP Z	ACTIVE	LQFP	PZ	100	90	RoHS & Green	NIPDAU	Level-3-260C-168 HR	-40 to 85	F6749A	Samples
MSP430F6749AIP ZR	ACTIVE	LQFP	PZ	100	1000	RoHS & Green	NIPDAU	Level-3-260C-168 HR	-40 to 85	F6749A	Samples

Orderable Device	Status (1)	Package Type	Package Drawing	Pins	Package Qty	Eco Plan (2)	Lead finish/ Ball material (6)	MSL Peak Temp (3)	Op Temp (°C)	Device Marking (4/5)	Samples
MSP430F6765AIP EU	ACTIVE	LQFP	PEU	128	72	RoHS & Green	NIPDAU	Level-3-260C-168 HR	-40 to 85	F6765A	Samples
MSP430F6765AIP EUR	ACTIVE	LQFP	PEU	128	750	RoHS & Green	NIPDAU	Level-3-260C-168 HR	-40 to 85	F6765A	Samples
MSP430F6765AIP Z	ACTIVE	LQFP	PZ	100	90	RoHS & Green	NIPDAU	Level-3-260C-168 HR	-40 to 85	F6765A	Samples
MSP430F6765AIP ZR	ACTIVE	LQFP	PZ	100	1000	RoHS & Green	NIPDAU	Level-3-260C-168 HR	-40 to 85	F6765A	Samples
MSP430F6766AIP EU	ACTIVE	LQFP	PEU	128	72	RoHS & Green	NIPDAU	Level-3-260C-168 HR	-40 to 85	F6766A	Samples
MSP430F6766AIP EUR	ACTIVE	LQFP	PEU	128	750	RoHS & Green	NIPDAU	Level-3-260C-168 HR	-40 to 85	F6766A	Samples
MSP430F6766AIP Z	ACTIVE	LQFP	PZ	100	90	RoHS & Green	NIPDAU	Level-3-260C-168 HR	-40 to 85	F6766A	Samples
MSP430F6766AIP ZR	ACTIVE	LQFP	PZ	100	1000	RoHS & Green	NIPDAU	Level-3-260C-168 HR	-40 to 85	F6766A	Samples
MSP430F6767AIP EU	ACTIVE	LQFP	PEU	128	72	RoHS & Green	NIPDAU	Level-3-260C-168 HR	-40 to 85	F6767A	Samples
MSP430F6767AIP EUR	ACTIVE	LQFP	PEU	128	750	RoHS & Green	NIPDAU	Level-3-260C-168 HR	-40 to 85	F6767A	Samples
MSP430F6767AIP Z	ACTIVE	LQFP	PZ	100	90	RoHS & Green	NIPDAU	Level-3-260C-168 HR	-40 to 85	F6767A	Samples
MSP430F6767AIP ZR	ACTIVE	LQFP	PZ	100	1000	RoHS & Green	NIPDAU	Level-3-260C-168 HR	-40 to 85	F6767A	Samples
MSP430F6768AIP EU	ACTIVE	LQFP	PEU	128	72	RoHS & Green	NIPDAU	Level-3-260C-168 HR	-40 to 85	F6768A	Samples
MSP430F6768AIP EUR	ACTIVE	LQFP	PEU	128	750	RoHS & Green	NIPDAU	Level-3-260C-168 HR	-40 to 85	F6768A	Samples
MSP430F6768AIP Z	ACTIVE	LQFP	PZ	100	90	RoHS & Green	NIPDAU	Level-3-260C-168 HR	-40 to 85	F6768A	Samples
MSP430F6768AIP ZR	ACTIVE	LQFP	PZ	100	1000	RoHS & Green	NIPDAU	Level-3-260C-168 HR	-40 to 85	F6768A	Samples
MSP430F6769AIP EU	ACTIVE	LQFP	PEU	128	72	RoHS & Green	NIPDAU	Level-3-260C-168 HR	-40 to 85	F6769A	Samples
MSP430F6769AIP EUR	ACTIVE	LQFP	PEU	128	750	RoHS & Green	NIPDAU	Level-3-260C-168 HR	-40 to 85	F6769A	Samples
MSP430F6769AIP Z	ACTIVE	LQFP	PZ	100	90	RoHS & Green	NIPDAU	Level-3-260C-168 HR	-40 to 85	F6769A	Samples
MSP430F6769AIP ZR	ACTIVE	LQFP	PZ	100	1000	RoHS & Green	NIPDAU	Level-3-260C-168 HR	-40 to 85	F6769A	Samples
MSP430F6775AIP EU	ACTIVE	LQFP	PEU	128	72	RoHS & Green	NIPDAU	Level-3-260C-168 HR	-40 to 85	F6775A	Samples

Orderable Device	Status (1)	Package Type	Package Drawing	Pins	Package Qty	Eco Plan (2)	Lead finish/ Ball material (6)	MSL Peak Temp (3)	Op Temp (°C)	Device Marking (4/5)	Samples
MSP430F6775A1PEUR	ACTIVE	LQFP	PEU	128	750	RoHS & Green	NIPDAU	Level-3-260C-168 HR	-40 to 85	F6775A	Samples
MSP430F6775A1PZ	ACTIVE	LQFP	PZ	100	90	RoHS & Green	NIPDAU	Level-3-260C-168 HR	-40 to 85	F6775A	Samples
MSP430F6775A1PZR	ACTIVE	LQFP	PZ	100	1000	RoHS & Green	NIPDAU	Level-3-260C-168 HR	-40 to 85	F6775A	Samples
MSP430F6776A1PEU	ACTIVE	LQFP	PEU	128	72	RoHS & Green	NIPDAU	Level-3-260C-168 HR	-40 to 85	F6776A	Samples
MSP430F6776A1PEUR	ACTIVE	LQFP	PEU	128	750	RoHS & Green	NIPDAU	Level-3-260C-168 HR	-40 to 85	F6776A	Samples
MSP430F6776A1PZ	ACTIVE	LQFP	PZ	100	90	RoHS & Green	NIPDAU	Level-3-260C-168 HR	-40 to 85	F6776A	Samples
MSP430F6776A1PZR	ACTIVE	LQFP	PZ	100	1000	RoHS & Green	NIPDAU	Level-3-260C-168 HR	-40 to 85	F6776A	Samples
MSP430F6777A1PEU	ACTIVE	LQFP	PEU	128	72	RoHS & Green	NIPDAU	Level-3-260C-168 HR	-40 to 85	F6777A	Samples
MSP430F6777A1PEUR	ACTIVE	LQFP	PEU	128	750	RoHS & Green	NIPDAU	Level-3-260C-168 HR	-40 to 85	F6777A	Samples
MSP430F6777A1PZ	ACTIVE	LQFP	PZ	100	90	RoHS & Green	NIPDAU	Level-3-260C-168 HR	-40 to 85	F6777A	Samples
MSP430F6777A1PZR	ACTIVE	LQFP	PZ	100	1000	RoHS & Green	NIPDAU	Level-3-260C-168 HR	-40 to 85	F6777A	Samples
MSP430F6778A1PEU	ACTIVE	LQFP	PEU	128	72	RoHS & Green	NIPDAU	Level-3-260C-168 HR	-40 to 85	F6778A	Samples
MSP430F6778A1PEUR	ACTIVE	LQFP	PEU	128	750	RoHS & Green	NIPDAU	Level-3-260C-168 HR	-40 to 85	F6778A	Samples
MSP430F6778A1PZ	ACTIVE	LQFP	PZ	100	90	RoHS & Green	NIPDAU	Level-3-260C-168 HR	-40 to 85	F6778A	Samples
MSP430F6778A1PZR	ACTIVE	LQFP	PZ	100	1000	RoHS & Green	NIPDAU	Level-3-260C-168 HR	-40 to 85	F6778A	Samples
MSP430F6779A1PEU	ACTIVE	LQFP	PEU	128	72	RoHS & Green	NIPDAU	Level-3-260C-168 HR	-40 to 85	F6779A	Samples
MSP430F6779A1PEUR	ACTIVE	LQFP	PEU	128	750	RoHS & Green	NIPDAU	Level-3-260C-168 HR	-40 to 85	F6779A	Samples
MSP430F6779A1PZ	ACTIVE	LQFP	PZ	100	90	RoHS & Green	NIPDAU	Level-3-260C-168 HR	-40 to 85	F6779A	Samples
MSP430F6779A1PZR	ACTIVE	LQFP	PZ	100	1000	RoHS & Green	NIPDAU	Level-3-260C-168 HR	-40 to 85	F6779A	Samples

(1) The marketing status values are defined as follows:

ACTIVE: Product device recommended for new designs.

LIFEBUY: TI has announced that the device will be discontinued, and a lifetime-buy period is in effect.

NRND: Not recommended for new designs. Device is in production to support existing customers, but TI does not recommend using this part in a new design.

PREVIEW: Device has been announced but is not in production. Samples may or may not be available.

OBSOLETE: TI has discontinued the production of the device.

⁽²⁾ **RoHS:** TI defines "RoHS" to mean semiconductor products that are compliant with the current EU RoHS requirements for all 10 RoHS substances, including the requirement that RoHS substance do not exceed 0.1% by weight in homogeneous materials. Where designed to be soldered at high temperatures, "RoHS" products are suitable for use in specified lead-free processes. TI may reference these types of products as "Pb-Free".

RoHS Exempt: TI defines "RoHS Exempt" to mean products that contain lead but are compliant with EU RoHS pursuant to a specific EU RoHS exemption.

Green: TI defines "Green" to mean the content of Chlorine (Cl) and Bromine (Br) based flame retardants meet JS709B low halogen requirements of ≤ 1000 ppm threshold. Antimony trioxide based flame retardants must also meet the ≤ 1000 ppm threshold requirement.

⁽³⁾ **MSL, Peak Temp.** - The Moisture Sensitivity Level rating according to the JEDEC industry standard classifications, and peak solder temperature.

⁽⁴⁾ There may be additional marking, which relates to the logo, the lot trace code information, or the environmental category on the device.

⁽⁵⁾ Multiple Device Markings will be inside parentheses. Only one Device Marking contained in parentheses and separated by a "~" will appear on a device. If a line is indented then it is a continuation of the previous line and the two combined represent the entire Device Marking for that device.

⁽⁶⁾ **Lead finish/Ball material** - Orderable Devices may have multiple material finish options. Finish options are separated by a vertical ruled line. Lead finish/Ball material values may wrap to two lines if the finish value exceeds the maximum column width.

Important Information and Disclaimer: The information provided on this page represents TI's knowledge and belief as of the date that it is provided. TI bases its knowledge and belief on information provided by third parties, and makes no representation or warranty as to the accuracy of such information. Efforts are underway to better integrate information from third parties. TI has taken and continues to take reasonable steps to provide representative and accurate information but may not have conducted destructive testing or chemical analysis on incoming materials and chemicals. TI and TI suppliers consider certain information to be proprietary, and thus CAS numbers and other limited information may not be available for release.

In no event shall TI's liability arising out of such information exceed the total purchase price of the TI part(s) at issue in this document sold by TI to Customer on an annual basis.

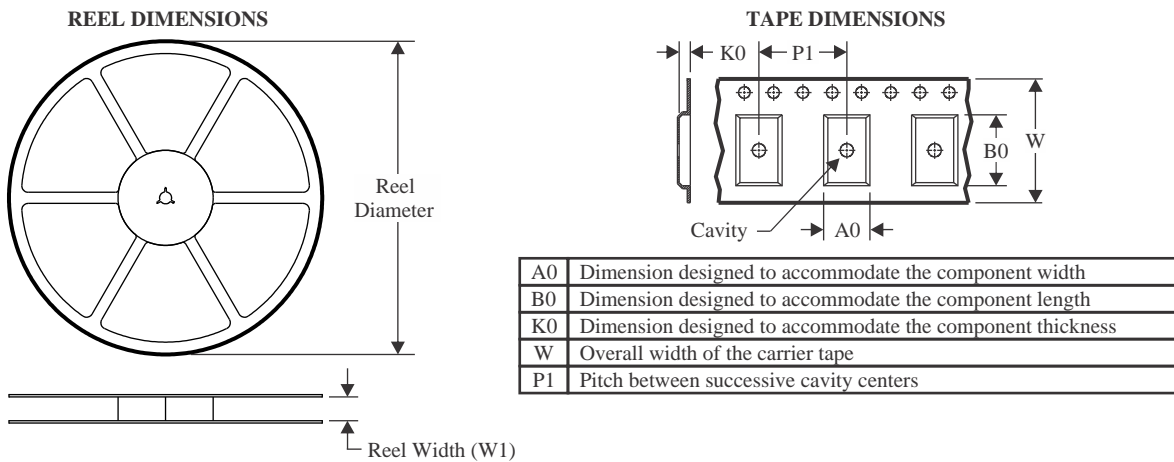
TAPE AND REEL INFORMATION

QUADRANT ASSIGNMENTS FOR PIN 1 ORIENTATION IN TAPE



*All dimensions are nominal

Device	Package Type	Package Drawing	Pins	SPQ	Reel Diameter (mm)	Reel Width W1 (mm)	A0 (mm)	B0 (mm)	K0 (mm)	P1 (mm)	W (mm)	Pin1 Quadrant
MSP430F6745AIPZR	LQFP	PZ	100	1000	330.0	24.4	17.0	17.0	2.1	20.0	24.0	Q2
MSP430F6746AIPZR	LQFP	PZ	100	1000	330.0	24.4	17.0	17.0	2.1	20.0	24.0	Q2
MSP430F6747AIPZR	LQFP	PZ	100	1000	330.0	24.4	17.0	17.0	2.1	20.0	24.0	Q2
MSP430F6748AIPZR	LQFP	PZ	100	1000	330.0	24.4	17.0	17.0	2.1	20.0	24.0	Q2
MSP430F6749AIPZR	LQFP	PZ	100	1000	330.0	24.4	17.0	17.0	2.1	20.0	24.0	Q2
MSP430F6765AIPZR	LQFP	PZ	100	1000	330.0	24.4	17.0	17.0	2.1	20.0	24.0	Q2
MSP430F6766AIPZR	LQFP	PZ	100	1000	330.0	24.4	17.0	17.0	2.1	20.0	24.0	Q2
MSP430F6767AIPZR	LQFP	PZ	100	1000	330.0	24.4	17.0	17.0	2.1	20.0	24.0	Q2
MSP430F6768AIPZR	LQFP	PZ	100	1000	330.0	24.4	17.0	17.0	2.1	20.0	24.0	Q2
MSP430F6769AIPZR	LQFP	PZ	100	1000	330.0	24.4	17.0	17.0	2.1	20.0	24.0	Q2
MSP430F6775AIPZR	LQFP	PZ	100	1000	330.0	24.4	17.0	17.0	2.1	20.0	24.0	Q2
MSP430F6776AIPZR	LQFP	PZ	100	1000	330.0	24.4	17.0	17.0	2.1	20.0	24.0	Q2
MSP430F6777AIPZR	LQFP	PZ	100	1000	330.0	24.4	17.0	17.0	2.1	20.0	24.0	Q2
MSP430F6778AIPZR	LQFP	PZ	100	1000	330.0	24.4	17.0	17.0	2.1	20.0	24.0	Q2
MSP430F6779AIPZR	LQFP	PZ	100	1000	330.0	24.4	17.0	17.0	2.1	20.0	24.0	Q2

TAPE AND REEL BOX DIMENSIONS

*All dimensions are nominal

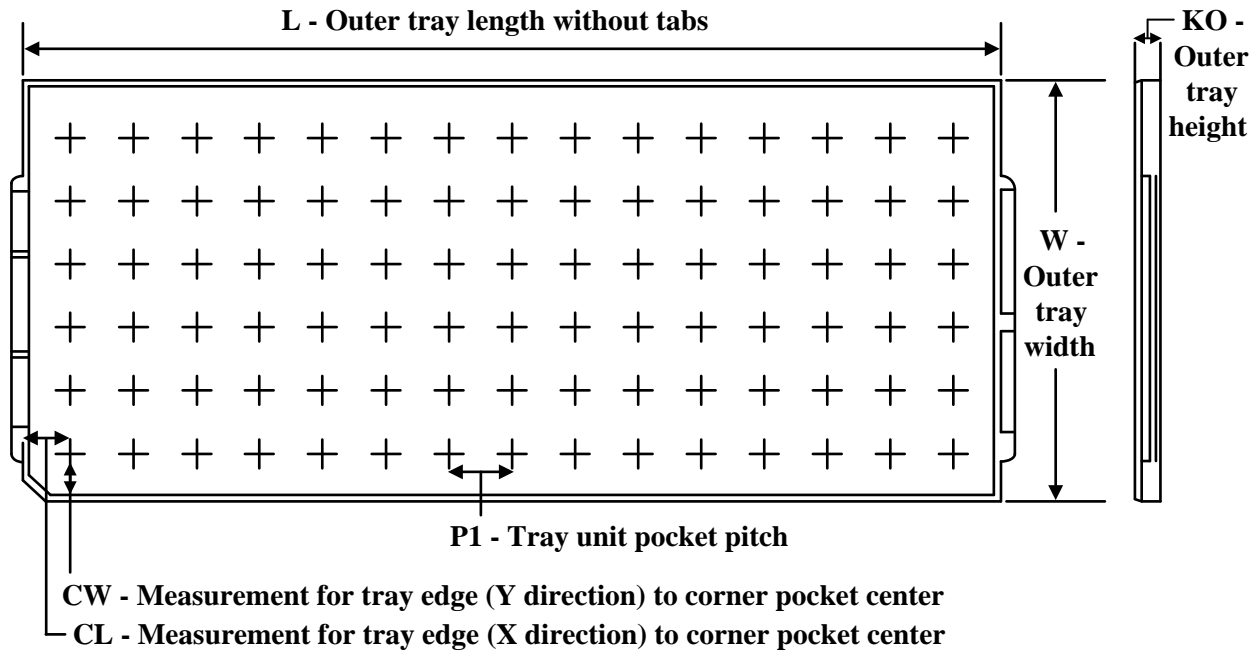
Device	Package Type	Package Drawing	Pins	SPQ	Length (mm)	Width (mm)	Height (mm)
MSP430F6745AIPZR	LQFP	PZ	100	1000	350.0	350.0	43.0
MSP430F6746AIPZR	LQFP	PZ	100	1000	350.0	350.0	43.0
MSP430F6747AIPZR	LQFP	PZ	100	1000	350.0	350.0	43.0
MSP430F6748AIPZR	LQFP	PZ	100	1000	350.0	350.0	43.0
MSP430F6749AIPZR	LQFP	PZ	100	1000	350.0	350.0	43.0
MSP430F6765AIPZR	LQFP	PZ	100	1000	350.0	350.0	43.0
MSP430F6766AIPZR	LQFP	PZ	100	1000	350.0	350.0	43.0
MSP430F6767AIPZR	LQFP	PZ	100	1000	350.0	350.0	43.0
MSP430F6768AIPZR	LQFP	PZ	100	1000	350.0	350.0	43.0
MSP430F6769AIPZR	LQFP	PZ	100	1000	350.0	350.0	43.0
MSP430F6775AIPZR	LQFP	PZ	100	1000	350.0	350.0	43.0
MSP430F6776AIPZR	LQFP	PZ	100	1000	350.0	350.0	43.0
MSP430F6777AIPZR	LQFP	PZ	100	1000	350.0	350.0	43.0
MSP430F6778AIPZR	LQFP	PZ	100	1000	350.0	350.0	43.0
MSP430F6779AIPZR	LQFP	PZ	100	1000	350.0	350.0	43.0

TRAY

Chamfer on Tray corner indicates Pin 1 orientation of packed units.

*All dimensions are nominal

Device	Package Name	Package Type	Pins	SPQ	Unit array matrix	Max temperature (°C)	L (mm)	W (mm)	K0 (µm)	P1 (mm)	CL (mm)	CW (mm)
MSP430F6745AIPEU	PEU	LQFP	128	72	6X12	150	315	135.9	7620	25.4	17.8	15.45
MSP430F6745AIPZ	PZ	LQFP	100	90	6 x 15	150	315	135.9	7620	20.3	15.4	15.45
MSP430F6746AIPEU	PEU	LQFP	128	72	6X12	150	315	135.9	7620	25.4	17.8	15.45
MSP430F6746AIPZ	PZ	LQFP	100	90	6 x 15	150	315	135.9	7620	20.3	15.4	15.45
MSP430F6747AIPEU	PEU	LQFP	128	72	6X12	150	315	135.9	7620	25.4	17.8	15.45
MSP430F6747AIPZ	PZ	LQFP	100	90	6 x 15	150	315	135.9	7620	20.3	15.4	15.45
MSP430F6748AIPEU	PEU	LQFP	128	72	6X12	150	315	135.9	7620	25.4	17.8	15.45
MSP430F6748AIPZ	PZ	LQFP	100	90	6 x 15	150	315	135.9	7620	20.3	15.4	15.45
MSP430F6749AIPEU	PEU	LQFP	128	72	6X12	150	315	135.9	7620	25.4	17.8	15.45
MSP430F6749AIPZ	PZ	LQFP	100	90	6 x 15	150	315	135.9	7620	20.3	15.4	15.45
MSP430F6765AIPEU	PEU	LQFP	128	72	6X12	150	315	135.9	7620	25.4	17.8	15.45
MSP430F6765AIPZ	PZ	LQFP	100	90	6 x 15	150	315	135.9	7620	20.3	15.4	15.45
MSP430F6766AIPEU	PEU	LQFP	128	72	6X12	150	315	135.9	7620	25.4	17.8	15.45
MSP430F6766AIPZ	PZ	LQFP	100	90	6 x 15	150	315	135.9	7620	20.3	15.4	15.45
MSP430F6767AIPEU	PEU	LQFP	128	72	6X12	150	315	135.9	7620	25.4	17.8	15.45
MSP430F6767AIPZ	PZ	LQFP	100	90	6 x 15	150	315	135.9	7620	20.3	15.4	15.45
MSP430F6768AIPEU	PEU	LQFP	128	72	6X12	150	315	135.9	7620	25.4	17.8	15.45

Device	Package Name	Package Type	Pins	SPQ	Unit array matrix	Max temperature (°C)	L (mm)	W (mm)	K0 (µm)	P1 (mm)	CL (mm)	CW (mm)
MSP430F6768AIPZ	PZ	LQFP	100	90	6 x 15	150	315	135.9	7620	20.3	15.4	15.45
MSP430F6769AIEU	PEU	LQFP	128	72	6X12	150	315	135.9	7620	25.4	17.8	15.45
MSP430F6769AIPZ	PZ	LQFP	100	90	6 x 15	150	315	135.9	7620	20.3	15.4	15.45
MSP430F6775AIEU	PEU	LQFP	128	72	6X12	150	315	135.9	7620	25.4	17.8	15.45
MSP430F6775AIPZ	PZ	LQFP	100	90	6 x 15	150	315	135.9	7620	20.3	15.4	15.45
MSP430F6776AIEU	PEU	LQFP	128	72	6X12	150	315	135.9	7620	25.4	17.8	15.45
MSP430F6776AIPZ	PZ	LQFP	100	90	6 x 15	150	315	135.9	7620	20.3	15.4	15.45
MSP430F6777AIEU	PEU	LQFP	128	72	6X12	150	315	135.9	7620	25.4	17.8	15.45
MSP430F6777AIPZ	PZ	LQFP	100	90	6 x 15	150	315	135.9	7620	20.3	15.4	15.45
MSP430F6778AIEU	PEU	LQFP	128	72	6X12	150	315	135.9	7620	25.4	17.8	15.45
MSP430F6778AIPZ	PZ	LQFP	100	90	6 x 15	150	315	135.9	7620	20.3	15.4	15.45
MSP430F6779AIEU	PEU	LQFP	128	72	6X12	150	315	135.9	7620	25.4	17.8	15.45
MSP430F6779AIPZ	PZ	LQFP	100	90	6 x 15	150	315	135.9	7620	20.3	15.4	15.45

MECHANICAL DATA

PEU (R-PQFP-G128)

PLASTIC QUAD FLATPACK

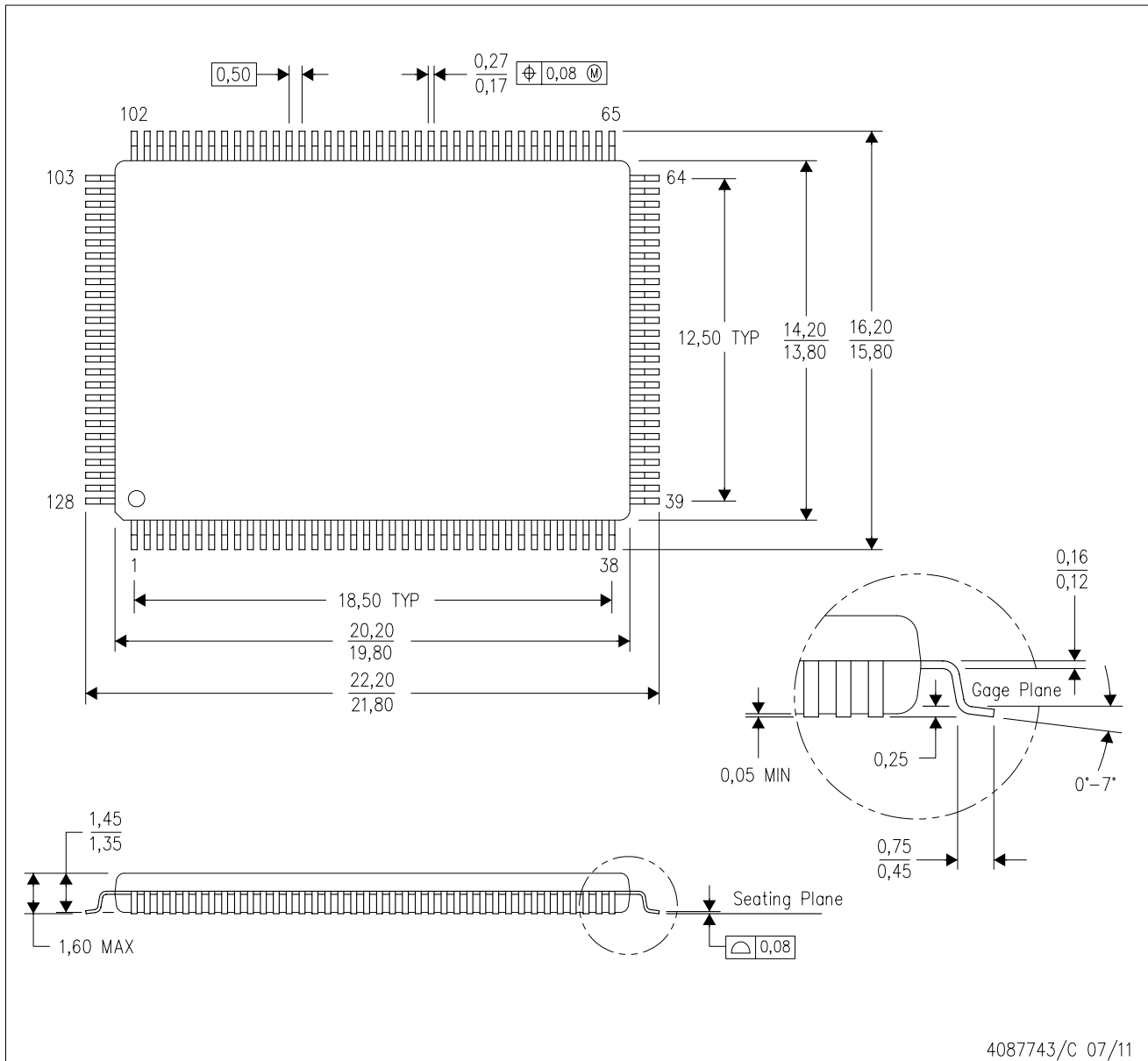

- NOTES:
- A. All linear dimensions are in millimeters. Dimensioning and tolerancing per ASME Y14.5M-1994.
 - B. This drawing is subject to change without notice.
 - C. Falls within JEDEC MS-026

PZ (S-PQFP-G100)

PLASTIC QUAD FLATPACK

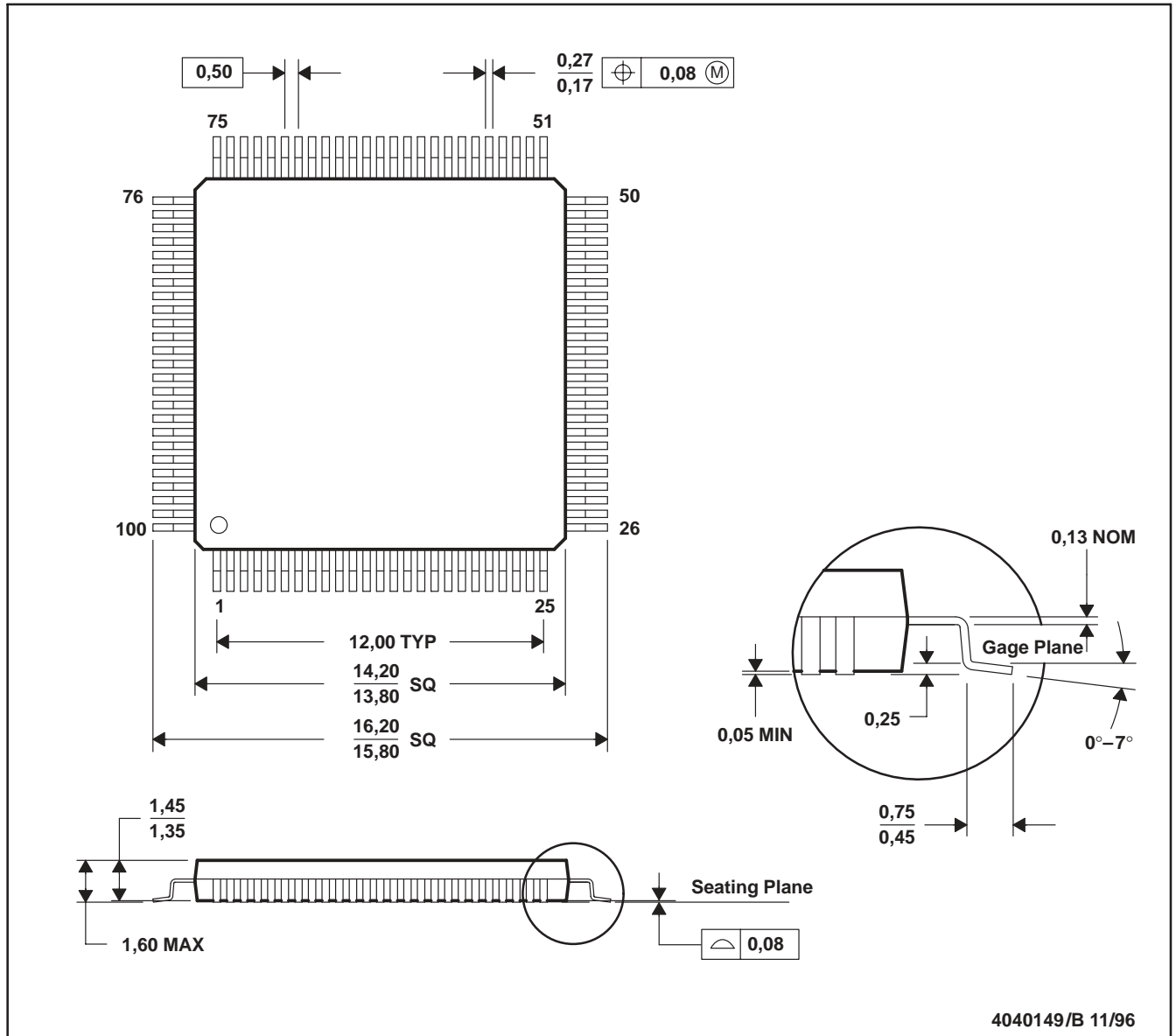

- NOTES: A. All linear dimensions are in millimeters.
 B. This drawing is subject to change without notice.
 C. Falls within JEDEC MS-026

IMPORTANT NOTICE AND DISCLAIMER

TI PROVIDES TECHNICAL AND RELIABILITY DATA (INCLUDING DATA SHEETS), DESIGN RESOURCES (INCLUDING REFERENCE DESIGNS), APPLICATION OR OTHER DESIGN ADVICE, WEB TOOLS, SAFETY INFORMATION, AND OTHER RESOURCES "AS IS" AND WITH ALL FAULTS, AND DISCLAIMS ALL WARRANTIES, EXPRESS AND IMPLIED, INCLUDING WITHOUT LIMITATION ANY IMPLIED WARRANTIES OF MERCHANTABILITY, FITNESS FOR A PARTICULAR PURPOSE OR NON-INFRINGEMENT OF THIRD PARTY INTELLECTUAL PROPERTY RIGHTS.

These resources are intended for skilled developers designing with TI products. You are solely responsible for (1) selecting the appropriate TI products for your application, (2) designing, validating and testing your application, and (3) ensuring your application meets applicable standards, and any other safety, security, regulatory or other requirements.

These resources are subject to change without notice. TI grants you permission to use these resources only for development of an application that uses the TI products described in the resource. Other reproduction and display of these resources is prohibited. No license is granted to any other TI intellectual property right or to any third party intellectual property right. TI disclaims responsibility for, and you will fully indemnify TI and its representatives against, any claims, damages, costs, losses, and liabilities arising out of your use of these resources.

TI's products are provided subject to [TI's Terms of Sale](#) or other applicable terms available either on ti.com or provided in conjunction with such TI products. TI's provision of these resources does not expand or otherwise alter TI's applicable warranties or warranty disclaimers for TI products.

TI objects to and rejects any additional or different terms you may have proposed.

Mailing Address: Texas Instruments, Post Office Box 655303, Dallas, Texas 75265
Copyright © 2022, Texas Instruments Incorporated